





Architecture

Imperial Hotel

Tokyo, Japan
Tokyo, Japon



 Booklet available in English on
 Livret disponible en français sur
 Folleto disponible en español en [Architecture.LEGO.com](https://www.lego.com/en-us/architecture)



Contents

Imperial Hotel.....	5
Its place in the history of architecture.....	6
Design and construction process.....	8
About the architect.....	12
The building today.....	14
Facts about the Imperial Hotel.....	16
A Word from the Artist.....	166
The 'Scale Model' line – LEGO Architecture in the 1960s	168
References.....	175

Table des matières

Hôtel Imperial.....	5
Sa place dans l'histoire de l'architecture.....	7
Le processus de conception et de construction.....	10
À propos de l'architecte.....	12
Le bâtiment aujourd'hui.....	14
Informations sur l'Hôtel Imperial.....	17
Un mot de l'artiste.....	166
La ligne "Modèle à l'échelle" :	
LEGO Architecture dans les années 1960	169
Références.....	175



Courtesy of the Frank Lloyd Wright Foundation
Avec l'aimable autorisation de la Frank Lloyd Wright Foundation.

Imperial Hotel

When Frank Lloyd Wright's legendary Imperial Hotel opened in 1923, it marked the emergence of Japan as a modern nation. The building quickly became the most famous landmark in Tokyo and it would go on to have a history as colorful and dramatic as the country itself. Eventually demolished in 1968, the iconic entrance and lobby wing was dismantled and rebuilt at the Meiji Mura Museum in Nagoya.

Hôtel Imperial

Lorsque le légendaire Hôtel Imperial de Frank Lloyd Wright ouvrit ses portes en 1923, il marqua l'émergence du Japon en tant que nation moderne. Le bâtiment est rapidement devenu le plus célèbre de Tokyo et son histoire fut aussi mouvementée et dramatique que celle du pays lui-même. L'hôtel fut éventuellement démoli en 1968, mais l'entrée et le hall emblématiques furent reconstruits au Musée Meiji Mura à Nagoya.



Its place in the history of architecture

The original Imperial Hotel was a three-story, wooden Victorian-style structure built across the avenue from the Emperor's palace. It opened in 1890 and was the only European-style hotel in the country at that time. By 1915 the hotel was no longer able to accommodate the growing numbers of visitors and it was decided to replace the out-dated building with a new modern hotel.

Looking for a western architect who could bridge the cultural divide between East and West, the hotel's owners commissioned Frank Lloyd Wright to design and build the new Imperial Hotel. In many ways Wright was the perfect choice for the task. He had long been fascinated with Japanese culture, especially after his first visit to the country in 1905, and had become an avid collector of Japanese prints.

Wright was glad to spend a great deal of time in Tokyo working on the project that consumed his attention, off and on, from 1916 to 1922. His goal from the outset was to design a building that would appeal to many and genuinely respect the Japanese culture.

The 250 room hotel was designed roughly in the shape of its own logo, with the guest room wings forming the letter "H", while the public rooms were in a smaller but taller central wing shaped like the letter "I" that cut through the middle of the "H". The visual effect of the planned design would be both stunning and dramatic.



Courtesy of the Frank Lloyd Wright Foundation

Sa place dans l'histoire de l'architecture

L'Hôtel Imperial d'origine était une structure en bois de style victorien de trois étages, construit en face du palais de l'Empereur. Il ouvrit ses portes en 1890 et était le seul hôtel de style européen dans le pays à l'époque. En 1915, l'hôtel n'était plus en mesure d'accueillir le nombre

croissant de visiteurs et il fut décidé de remplacer le bâtiment ancien par un hôtel moderne.

Souhaitant un architecte occidental qui pouvait combler le fossé culturel entre l'Est et l'Ouest, les propriétaires de l'hôtel chargèrent Frank Lloyd Wright de concevoir et de construire le nouvel Hôtel Imperial. Wright était le choix idéal pour cette tâche, pour de nombreuses raisons. Il était depuis longtemps fasciné par la culture japonaise, en particulier après sa première visite dans le pays en 1905, et il était devenu un collectionneur passionné d'estampes japonaises.

Wright était heureux de passer beaucoup de temps à Tokyo pour travailler sur le projet, qui accapara son attention de façon intermittente de 1916 à 1922. Son objectif dès le début était de concevoir un bâtiment attirant pour un grand nombre de personnes, en respectant sincèrement la culture japonaise.

L'hôtel de 250 chambres fut conçu en imitant la forme de son propre logo, les ailes des chambres formant la lettre « H », tandis que les espaces publics étaient situés dans une aile centrale plus petite mais plus haute en forme de « I » au milieu du « H ». L'effet visuel de cette conception était à la fois spectaculaire et dramatique.

© Frank Lloyd Wright Foundation

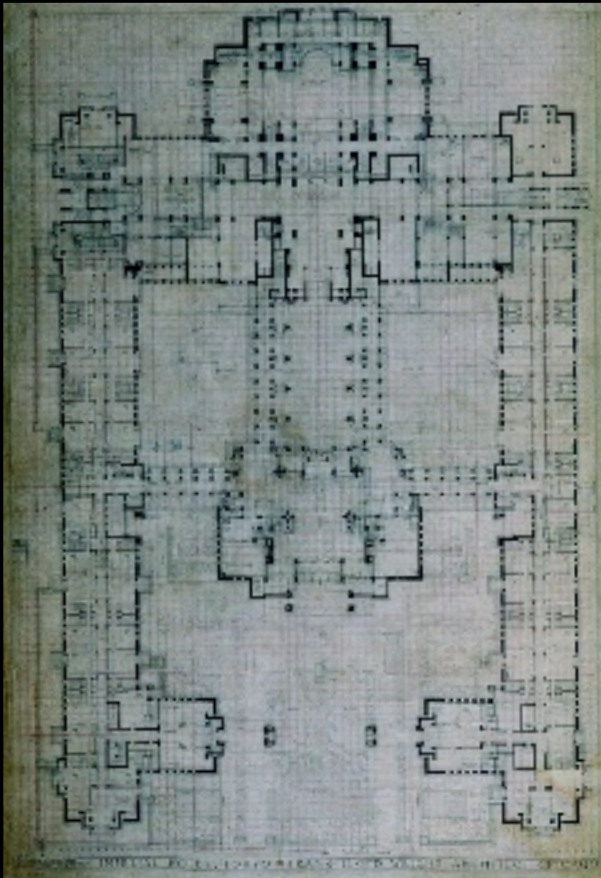

The design & construction process

Courtesy of the Frank Lloyd Wright Foundation

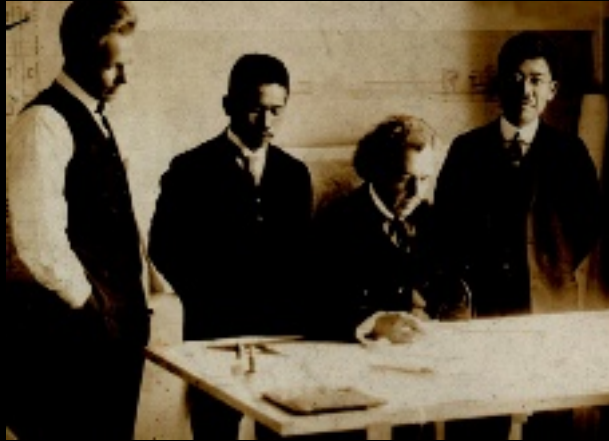

Wright worked on the Imperial Hotel with 18 to 20 Japanese draftsmen, the only other foreigner apart from himself being Paul Mueller, an experienced builder from Chicago.

One of the major concerns during the initial design and construction process was how to safeguard the building from the many earthquakes that occurred in the area. Wright had noted that Japanese architects, trained by centuries of natural disasters, always “built lightly on the ground.”

With between 18m and 21m (60-70 ft.) of alluvial mud beneath the 2.4m (8 ft.) of surface soil, it would be impossible to obtain the rigidity needed for traditional foundations. Instead his idea was to float the building upon the mud using shallow, broad footings. This

would allow it—in Wright’s terms—“to balance like a tray on a waiter’s fingertips.”

Other design features to combat the threat caused by earthquakes included cantilevered floors and balconies to provide extra support, seismic separation joints every 20m (65.6 ft.) along the building, tapered walls that were thicker on the lower floors, plus the consistent use of smooth curves which were more resistant to fracture.

The main building materials used were reinforced poured concrete and brick, while the choice of soft volcanic Oya stone enabled the extensive carving of elaborate ornamental carving and decoration. Wright was particularly impressed by the craftsmanship of the Japanese stonemasons. So much so he modified many of his original decorative concepts to make the most of their talents.



Courtesy of the Frank Lloyd Wright Foundation

Furnishings were exquisite. Furniture was designed for specific seating areas and the restaurants. Oya stone carvings in the shape of peacocks and other intricate patterns adorned the walls; ceilings were hand painted or embellished in gold leaf on both interior and exterior wall surfaces. Over a hundred specially designed abstract, geometric, patterned rugs and carpets were created by Wright so they could be easily woven in

China. The new Imperial Hotel opened on September 1st 1923. The same day a massive earthquake would rock Tokyo and the surrounding area. Wright was in Los Angeles at the time and it would be ten long days of conflicting reports before it was confirmed that hotel still stood. Indeed, thanks to Wright's unique design features, it would be one of the few buildings to survive the quake.



Le processus de conception et de construction

Courtesy of the Frank Lloyd Wright Foundation
Avec l'aimable autorisation de la Frank Lloyd Wright Foundation



Wright travailla sur l'Hôtel Imperial avec 18 à 20 artisans japonais, le seul autre étranger participant à part lui était Paul Mueller, un constructeur expérimenté de Chicago.

L'une des principales préoccupations pendant le processus initial de conception et de construction était de savoir comment protéger le bâtiment des nombreux tremblements de terre de la zone. Wright avait noté que les architectes japonais, formés par des siècles de catastrophes naturelles, « construisaient toujours légèrement sur le sol ».

Avec entre 18 m et 21 m de boue alluviale sous le sol en surface de 2,4 m, il était impossible d'obtenir la rigidité nécessaire pour des fondations traditionnelles. L'idée de Wright était de faire flotter le bâtiment sur la boue en utilisant des fondations larges et peu profondes. Ceci lui

permettrait, selon les termes de Wright, « de se balancer comme un plateau au bout des doigts d'un serveur ».

Les autres caractéristiques conçues pour lutter contre la menace causée par les tremblements de terre incluaient des sols et des balcons en porte-à-faux pour fournir un support supplémentaire, des joints de séparation sismiques tous les 20 m le long du bâtiment, des murs effilés qui étaient plus épais aux étages inférieurs, et l'utilisation constante de courbes douces qui se fracturaient moins facilement.

Les matériaux du bâtiment principal étaient du béton armé et de la brique, et le choix de la pierre volcanique légère d'Oya permit de sculpter de nombreuses décorations. Wright était particulièrement impressionné par la compétence des tailleurs de pierre japonais, à tel point qu'il modifia nombre de ses concepts décoratifs d'origine pour utiliser au mieux leurs talents.

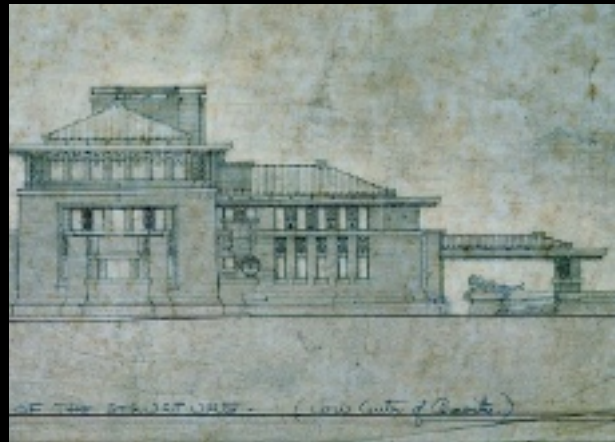

© Frank Lloyd Wright Foundation

Les aménagements étaient magnifiques. Des meubles furent spécialement créés pour certaines pièces et pour les restaurants. Des sculptures en pierre d'Oya en forme de paons et autres motifs élaborés décoraient les murs. Les plafonds étaient peints à la main ou ornés de feuille d'or. Plus de 100 tapis dans des motifs géométriques abstraits furent conçus spécialement par Wright et tissés en Chine.

Le nouvel Hôtel Imperial ouvrit ses portes le 1er septembre 1923. Le même jour, un énorme tremblement de terre secoua Tokyo et les environs. Wright était alors à Los Angeles et il fallut dix longs jours de rapports contradictoires pour confirmer enfin que l'hôtel était toujours debout. Grâce aux caractéristiques de conception uniques de Wright, l'hôtel était l'un des rares bâtiments à avoir survécu au tremblement de terre.



*Courtesy of the Frank Lloyd Wright Foundation
Avec l'aimable autorisation de la Frank Lloyd Wright Foundation*

About the architect

Arguably America's greatest architect and among the world's most gifted, Frank Lloyd Wright was also a man of boundless energy. In a career that spanned over 74 years, he designed more than 900 works – including houses, offices, churches, schools, libraries, bridges, museums and many other building types. Of that total, over 500 resulted in completed works. Today, over 400 of these buildings still remain.

Wright's creative mind was not only confined to architecture. He also designed furniture, fabrics, art glass, lamps, dinnerware, silver, linens and graphic arts. In addition, he was a prolific writer, an educator and a philosopher. He authored twenty books and countless articles, lectured throughout the United States and in Europe.

Wright was born in 1867, in the rural farming town of Richland Center, Wisconsin, just two years after the American Civil War ended and passed away at the age of 91 in 1959. While there is evidence of Wright attending both high school and the University of Wisconsin-Madison, there is no record of him graduating from either. In 1887 Wright moved to Chicago and by the early 1890s he was already head draftsman at the architectural firm of Adler & Sullivan.

As an architect and artist Wright was both intrigued and inspired by the Far East, and especially Japan. He would eventually design and complete six buildings in the country, the most famous being the Imperial Hotel

Wright was recognized as a brilliant architect by his peers and continues to be revered today. No other architecture took greater advantage of setting and environment. No other architect glorified the sense of "shelter" as did Frank Lloyd Wright. As he famously stated: "a building is not just a place to be. It is a way to be.

À propos de l'architecte

Sans doute le plus grand architecte américain et l'un des plus doués au monde, Frank Lloyd Wright était aussi un homme à l'énergie illimitée. Dans une carrière qui a duré plus de 74 ans, il a conçu plus de 900 œuvres, notamment des maisons, des bureaux, des églises, des écoles, des bibliothèques, des ponts, des musées et de nombreux autres types de bâtiments. Sur ce total, plus de 500 ont donné des projets terminés et plus de 400 de ces bâtiments existent toujours aujourd'hui.

L'esprit créatif de Wright ne se limitait pas à l'architecture. Il créa aussi des meubles, des tissus, des objets en verre, des lampes, de la vaisselle, de l'argenterie, du linge et des réalisations graphiques. Il était aussi un écrivain prolifique, un pédagogue et un philosophe. Il écrivit vingt livres et d'innombrables

articles et fit des conférences dans tous les États-Unis et en Europe.

Wright est né en 1867, dans la ville agricole de Richland Center, Wisconsin, seulement deux ans après la fin de la guerre civile américaine. Il mourut en 1959 à l'âge de 91 ans. Wright a suivi les cours du lycée et de l'Université de Wisconsin-Madison, mais il n'y a aucune preuve qu'il en ait été diplômé. En 1887, Wright s'installa à Chicago, et dès le début des années 1890, il était déjà dessinateur en chef dans le cabinet d'architecture Adler & Sullivan.

Comme architecte et artiste, Wright était à la fois intrigué et inspiré par l'Extrême-Orient, en particulier par le Japon. Il allait éventuellement concevoir et terminer six bâtiments dans ce pays, le plus célèbre étant l'Hôtel Imperial.

Wright était reconnu comme un architecte brillant par ses pairs et continue d'être révééré aujourd'hui. Aucun autre architecte n'a plus tiré parti du cadre et de l'environnement ou glorifié le sens « d'abri » comme il l'a fait. Il l'a lui-même exposé dans une citation célèbre : « Un bâtiment n'est pas seulement un endroit où être. C'est une façon d'être ».



The building today

By 1968, the Wright designed Imperial Hotel had survived several earthquakes, a growing Japanese population, and increased pollution which had deteriorated some of the intricate Oya stone carvings and other decorative details of this masterpiece. Thousands of hotel guests had stayed, visited, or attended grand events held at the hotel.

Current management made a most difficult and controversial decision to demolish this iconic Japanese landmark to make way for a newer and larger multi-story structure. However, the main entrance and lobby wing were carefully dismantled and rebuilt at the Meiji Mura Museum and can be seen in Nogoya, Japan.

Le bâtiment aujourd'hui

En 1968, l'Hôtel Imperial conçu par Wright avait survécu à plusieurs tremblements de terre, à la croissance de la population japonaise, et à la hausse de la pollution, qui avait endommagé certaines des sculptures élaborées en pierre d'Oya et d'autres détails décoratifs de ce chef-d'œuvre. Des milliers de clients avaient séjourné dans l'hôtel, et de nombreux autres l'avaient visité ou y avaient assisté à de grands événements.

La direction prit la décision très difficile et controversée de démolir ce bâtiment emblématique japonais pour le remplacer par une structure plus neuve et plus grande avec de nombreux étages. Cependant, l'entrée principale et le hall furent soigneusement démontés et remontés dans le Musée Meiji Mura à Nagoya, au Japon.



Facts about the Imperial Hotel

Location:..... Originally Tokyo, Japan
Architect: Frank Lloyd Wright
Date: 1916-1923
Construction type: Hotel: 250 rooms, 5 ballrooms, 10
banquet rooms
Materials:..... Reinforced Concrete and Brick
Original Cost: Approximately 6 million yen
Surface area:..... 34.765m² (114 058.399 sq. ft.)



© Frank Lloyd Wright Foundation

Informations sur l'Hôtel Imperial

Lieu : À l'origine Tokyo, Japon
Architecte : Frank Lloyd Wright
Date : 1916-1923
Type de construction : . Hôtel : 250 chambres, 5 salles de
bal, 10 salles de banquet
Matériaux : Béton armé et brique
Coût original : Environ 6 millions de yens
Superficie : 34 765 m²

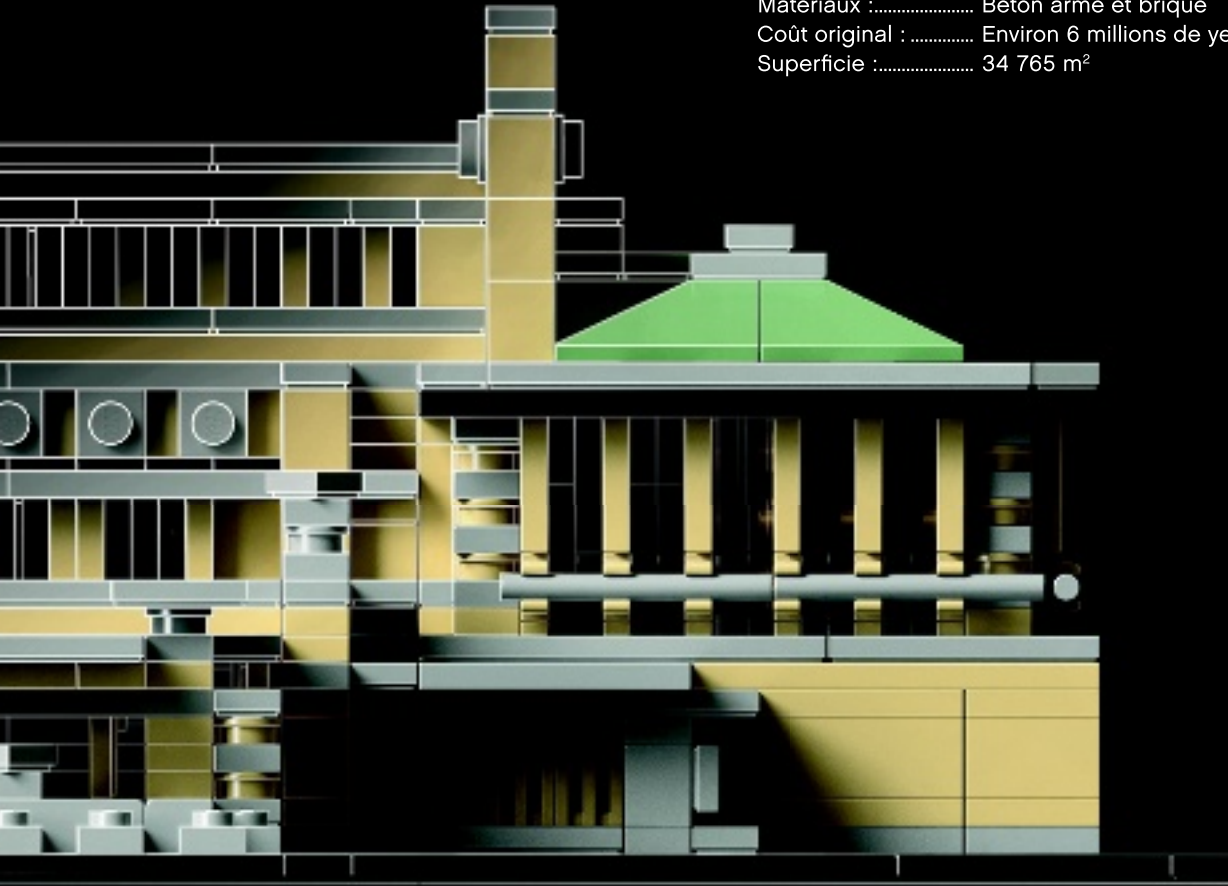

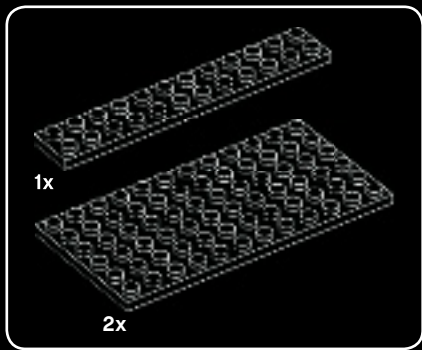

1

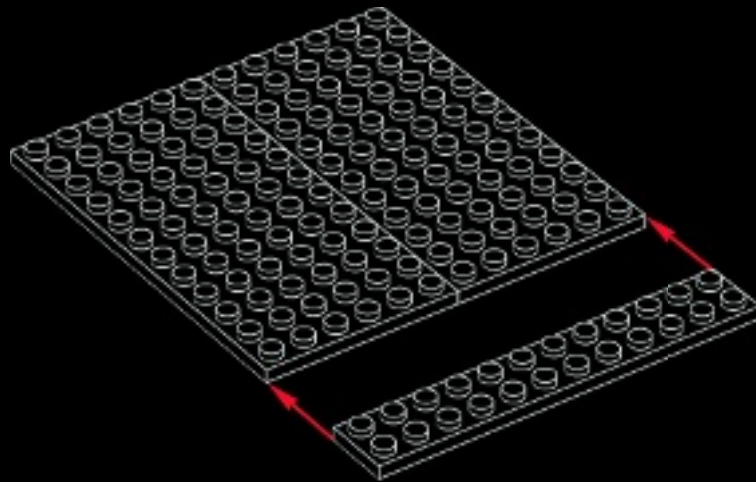

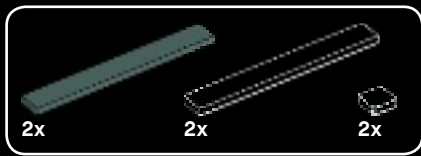

2

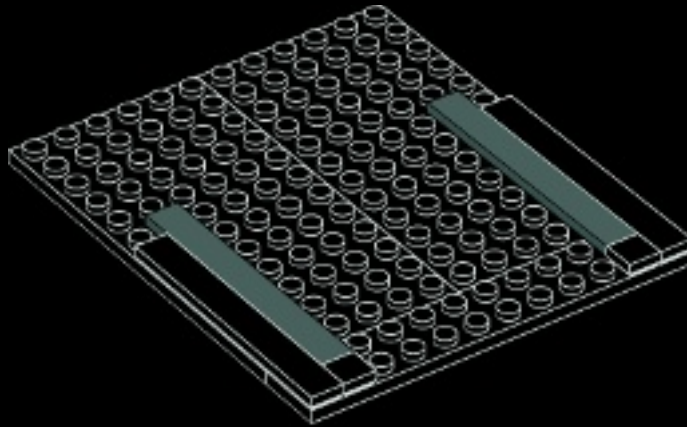

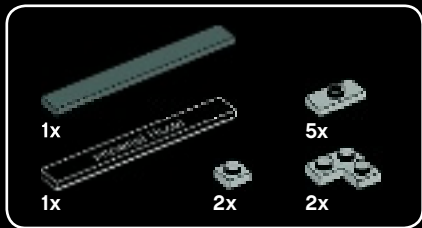

3

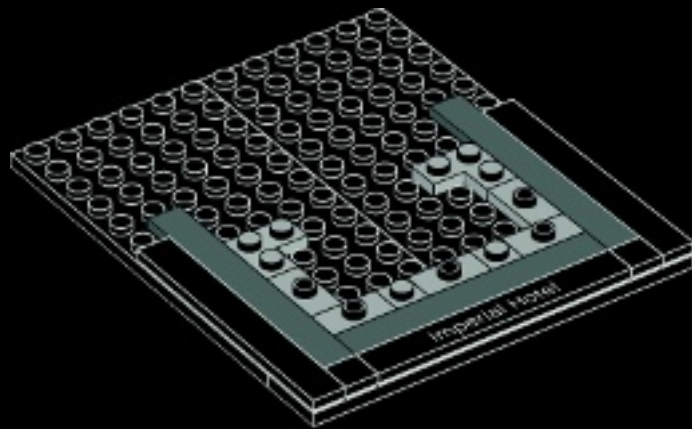

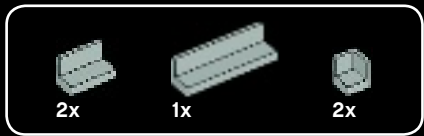

4

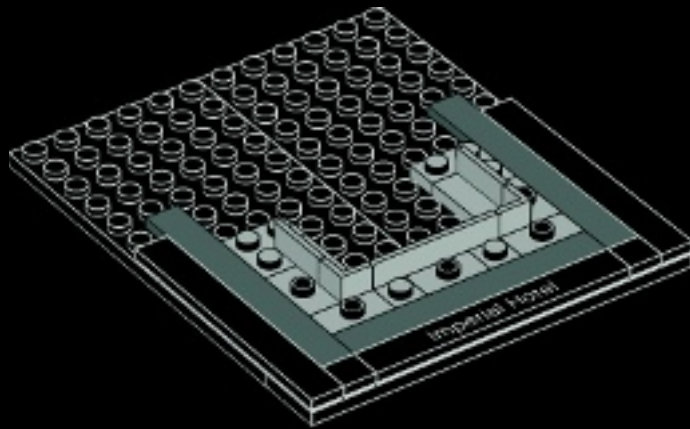



5

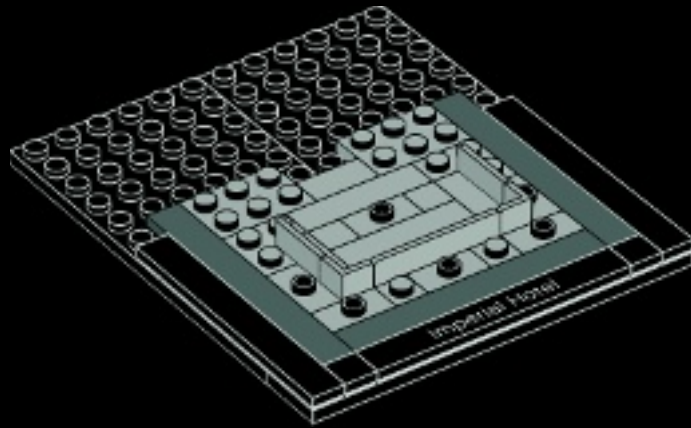

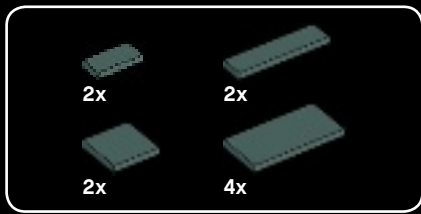

6

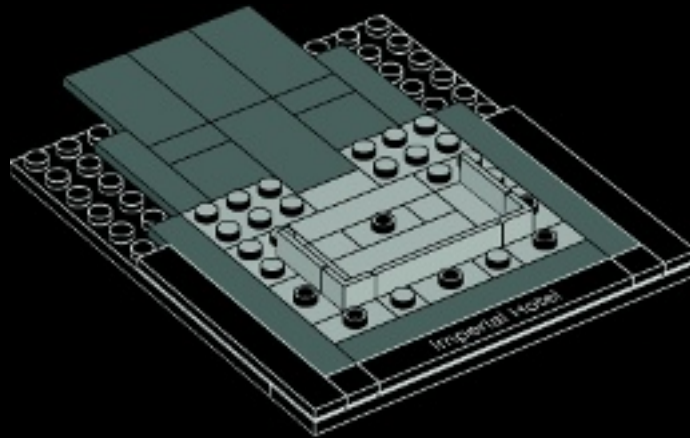

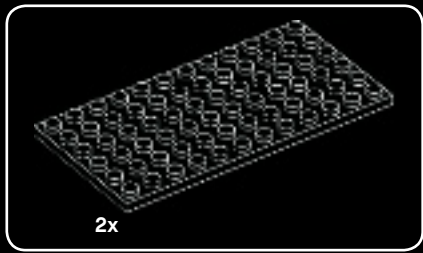

7

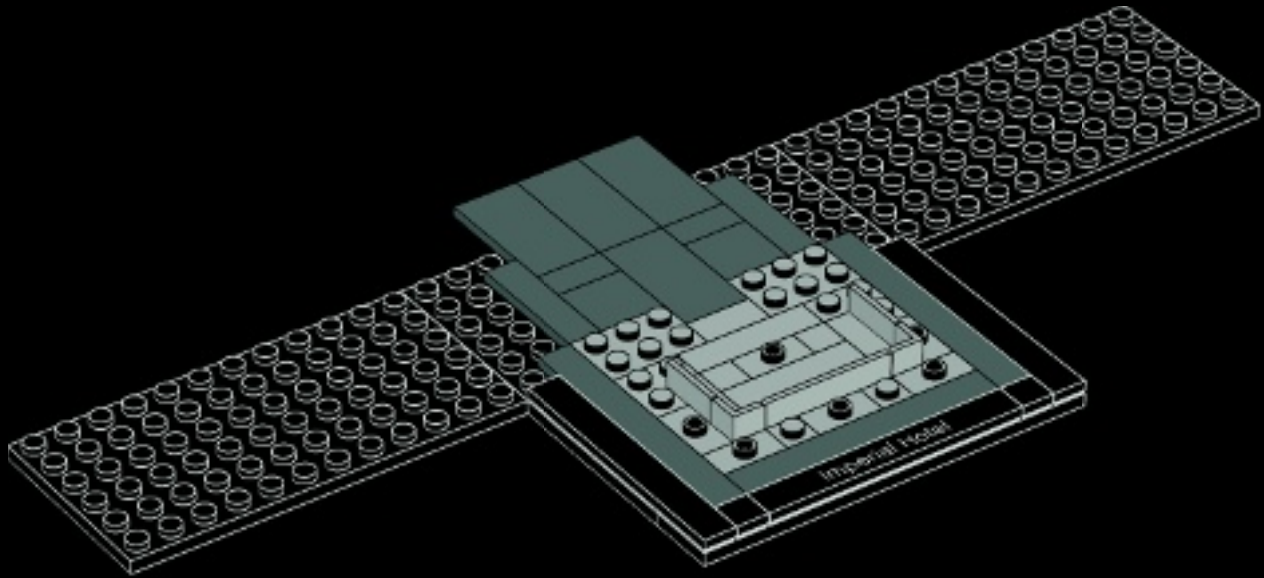

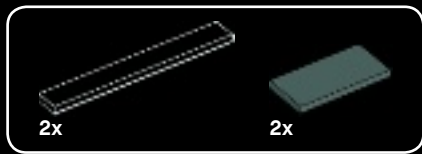

8

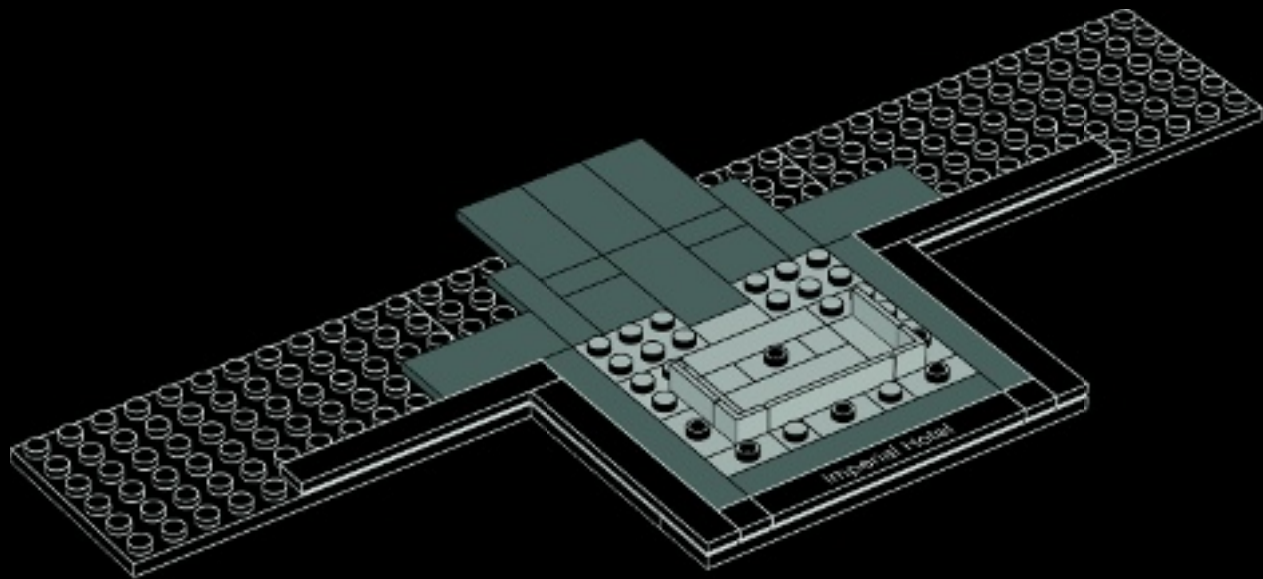

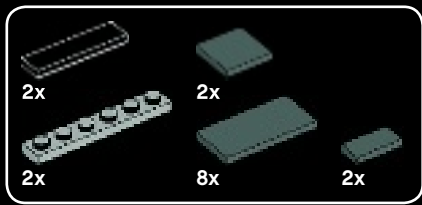

9

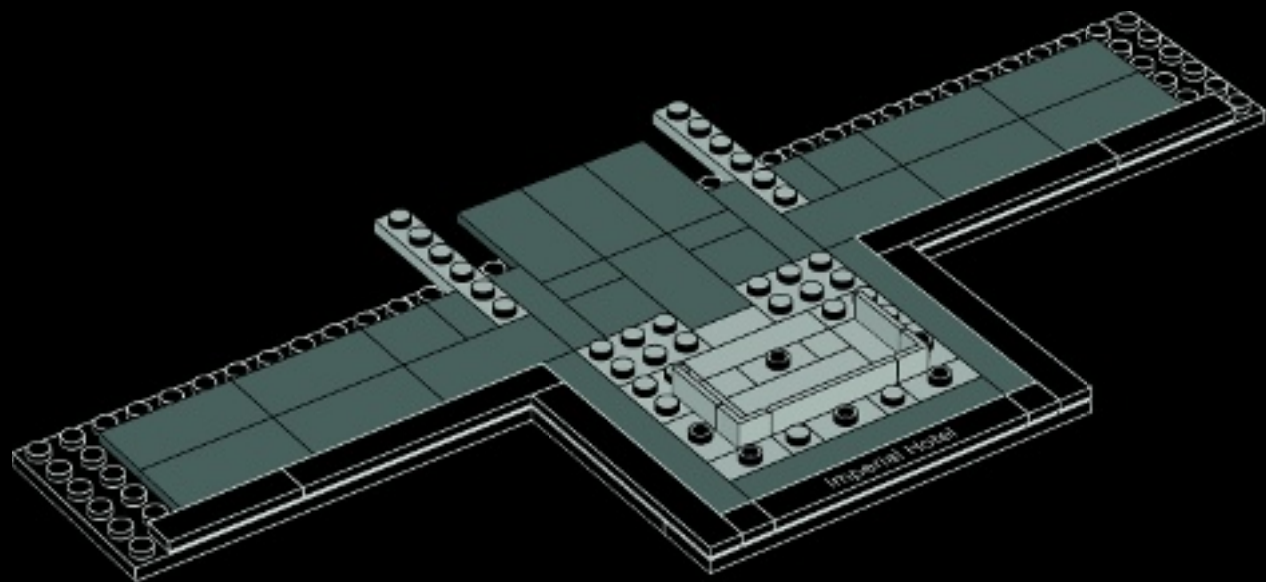

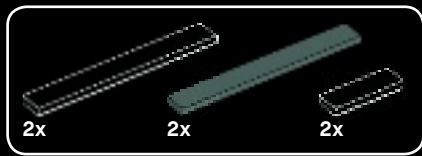

10

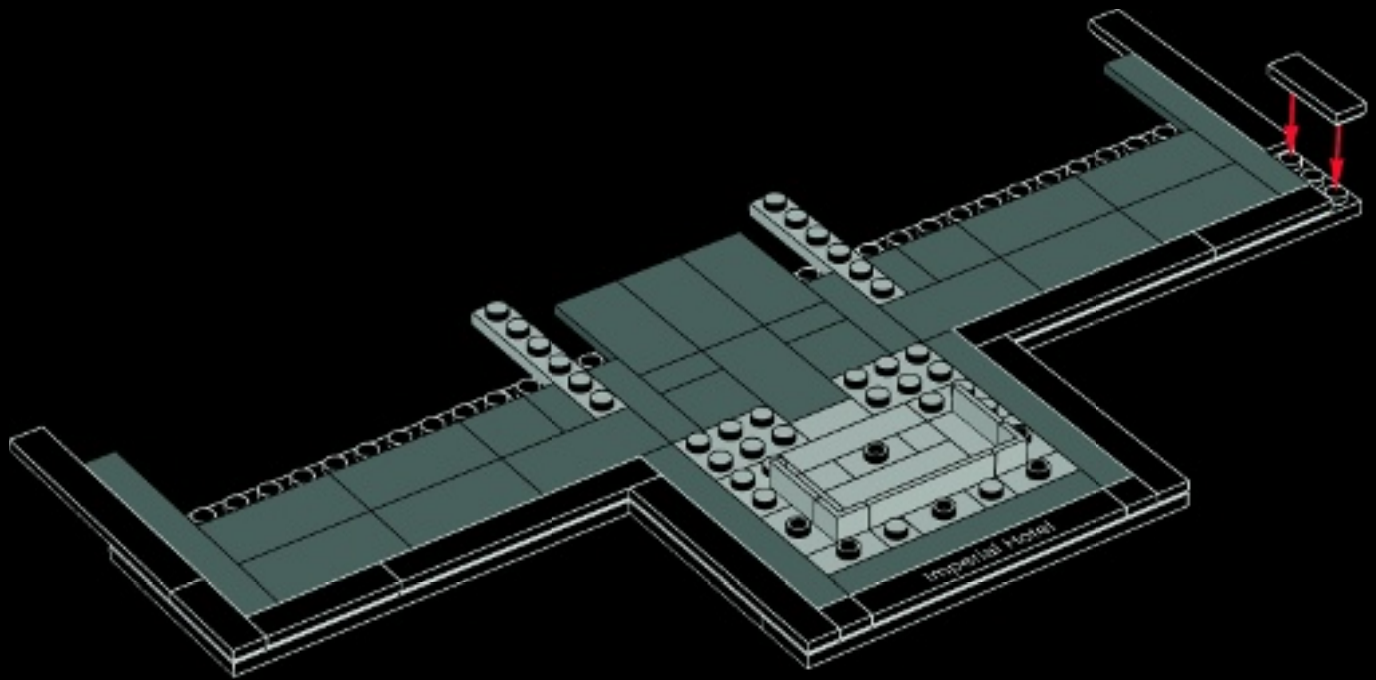

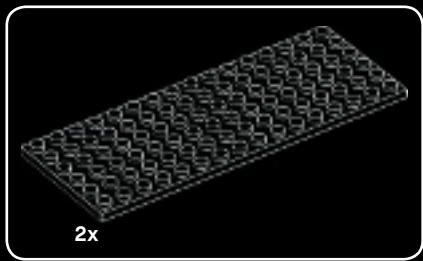

11

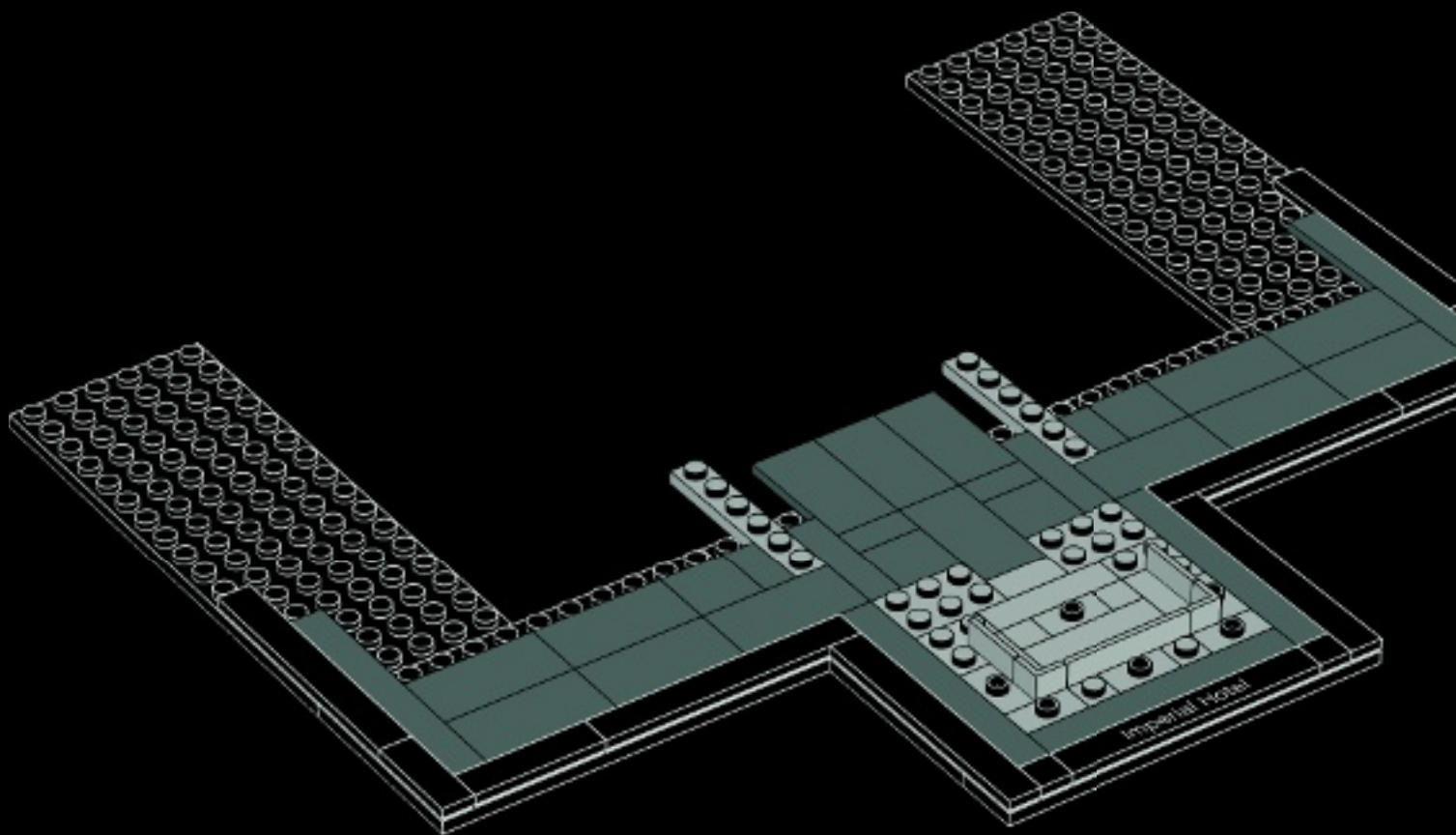

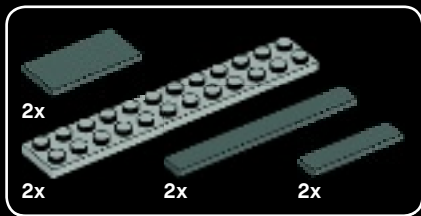

12

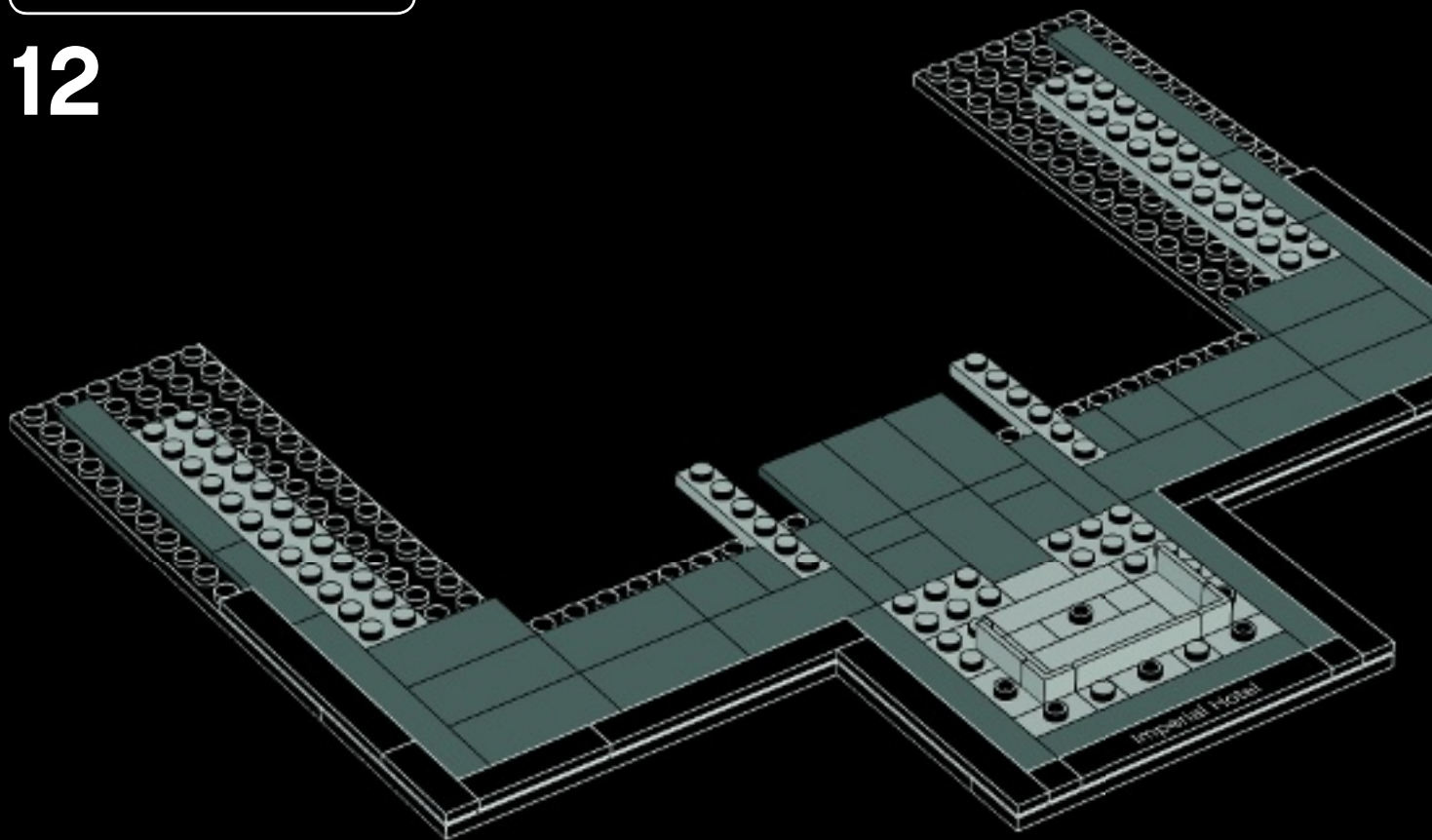

Wright expected the shallow foundations of the hotel would allow the foundations to “balance like a tray on waiters’ fingertips”.

Wright s’attendait à ce que les fondations peu profondes de l’hôtel lui permette de « se balancer comme un plateau au bout des doigts d’un serveur ».



© Frank Lloyd Wright Foundation

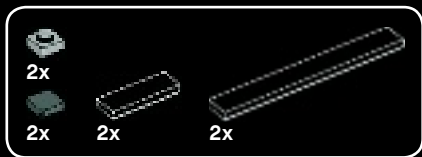

13

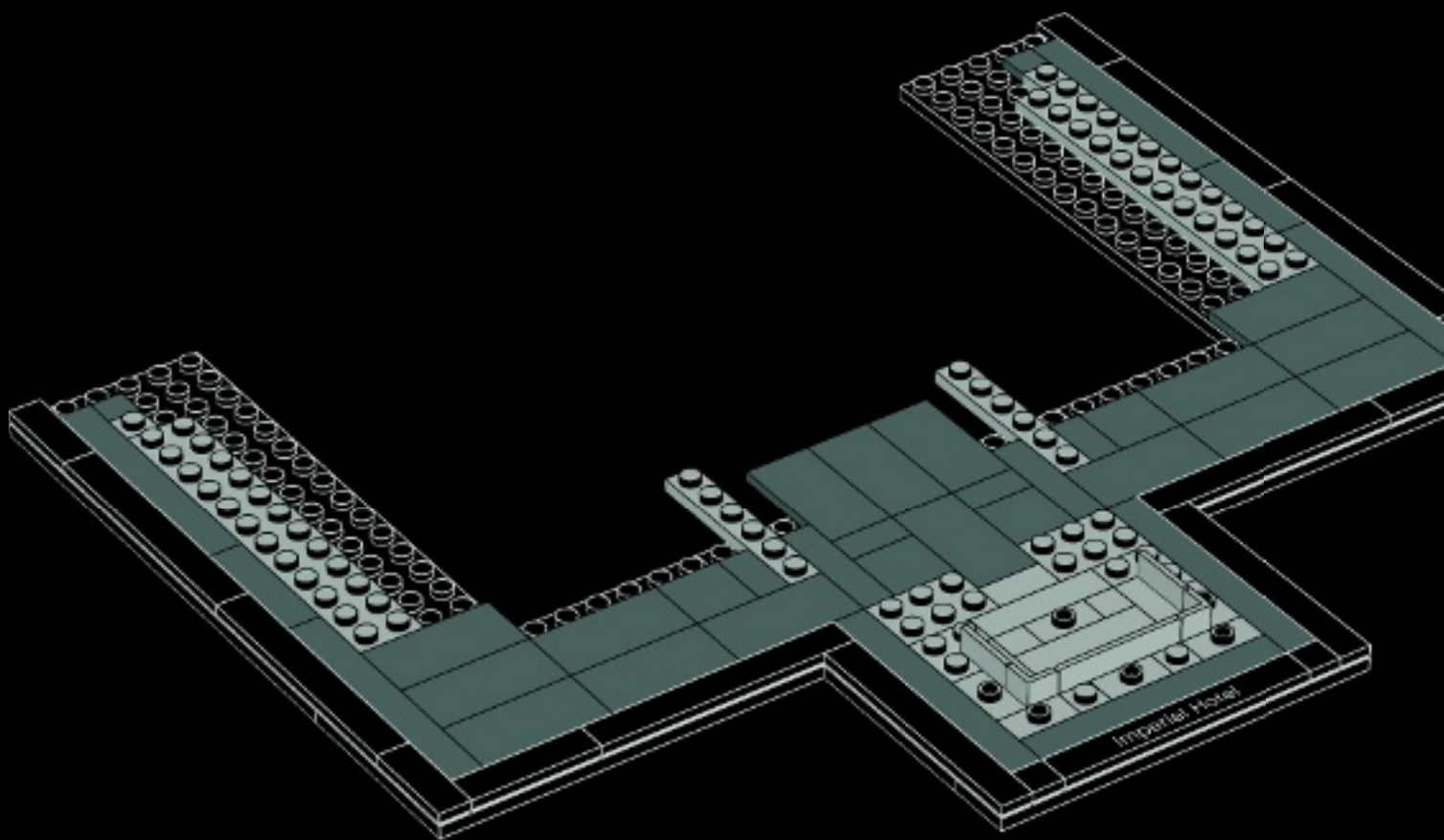

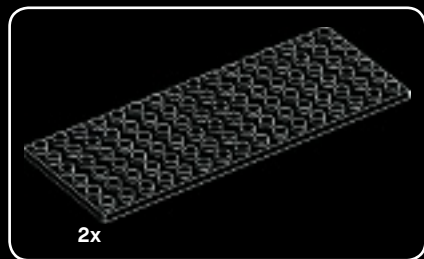

14

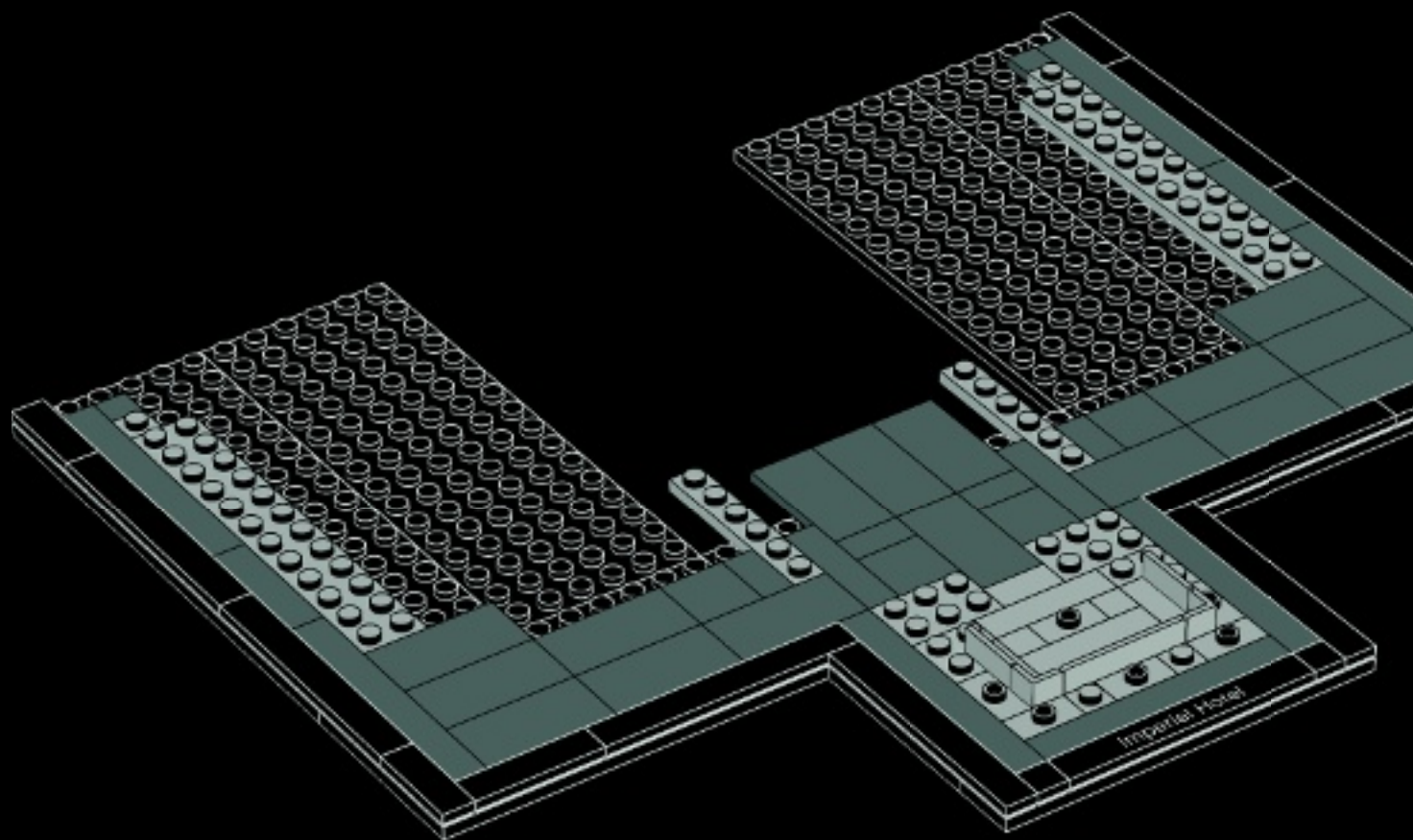

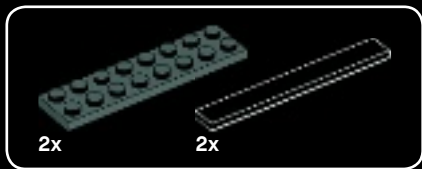

15

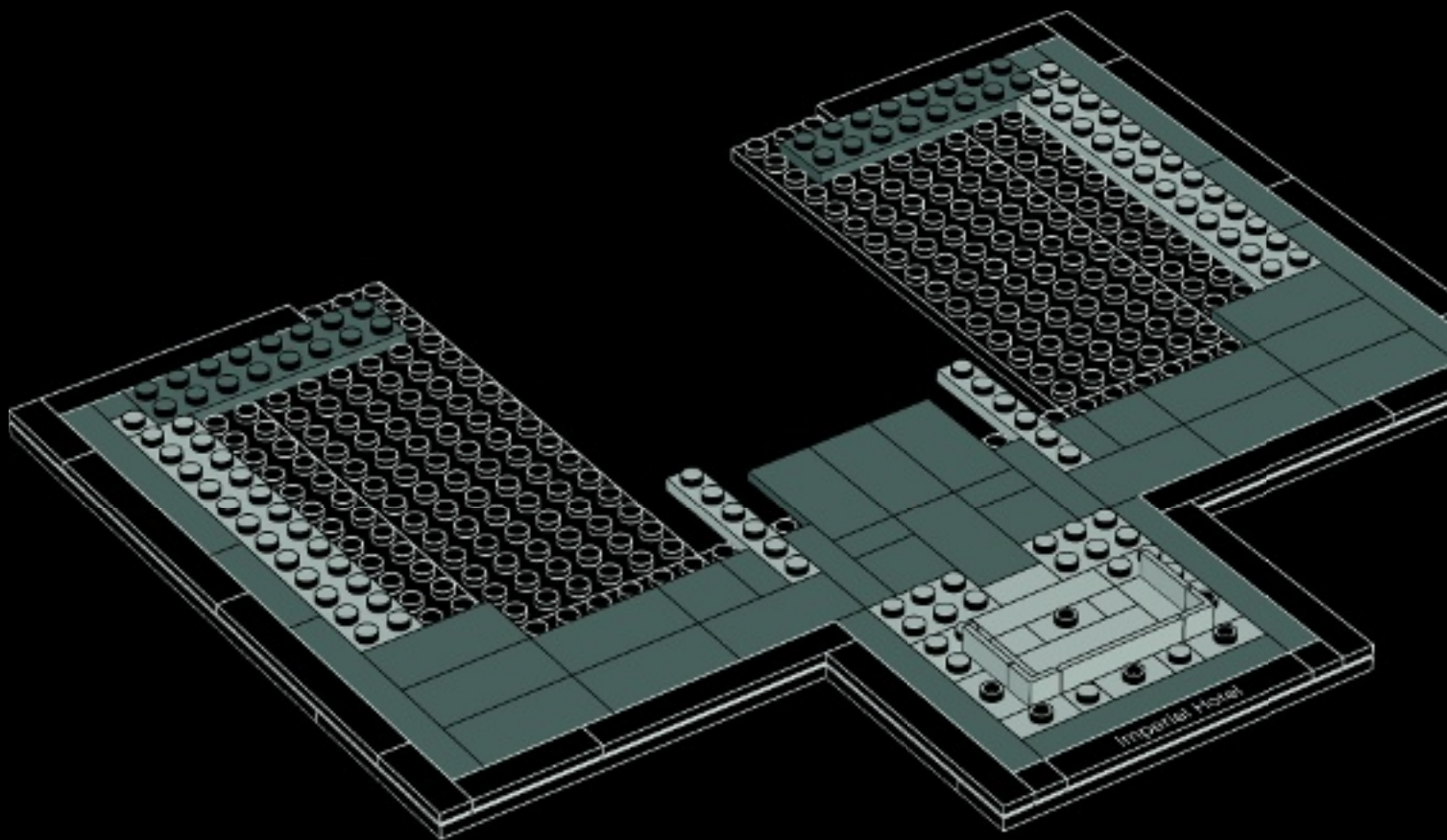



16

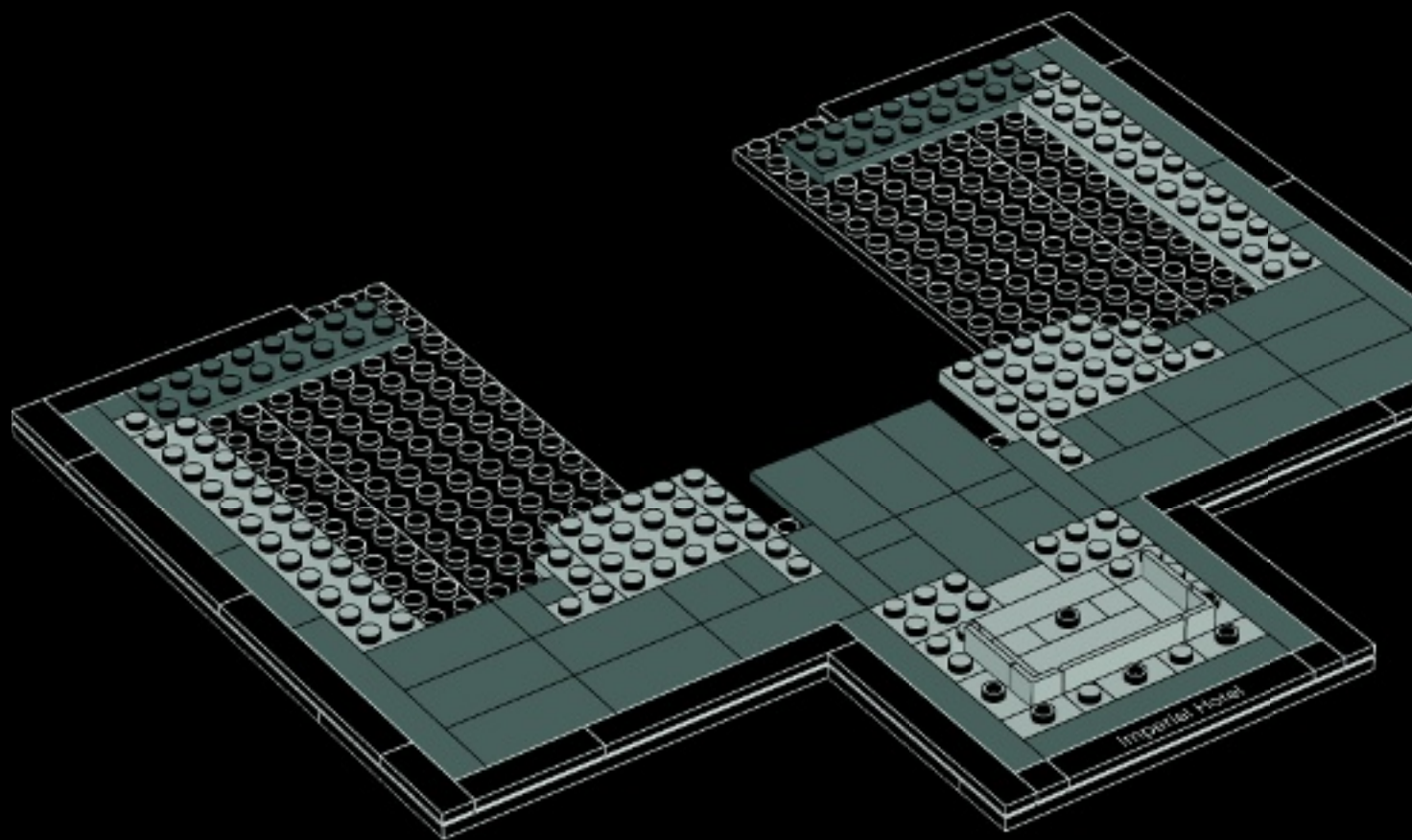



17

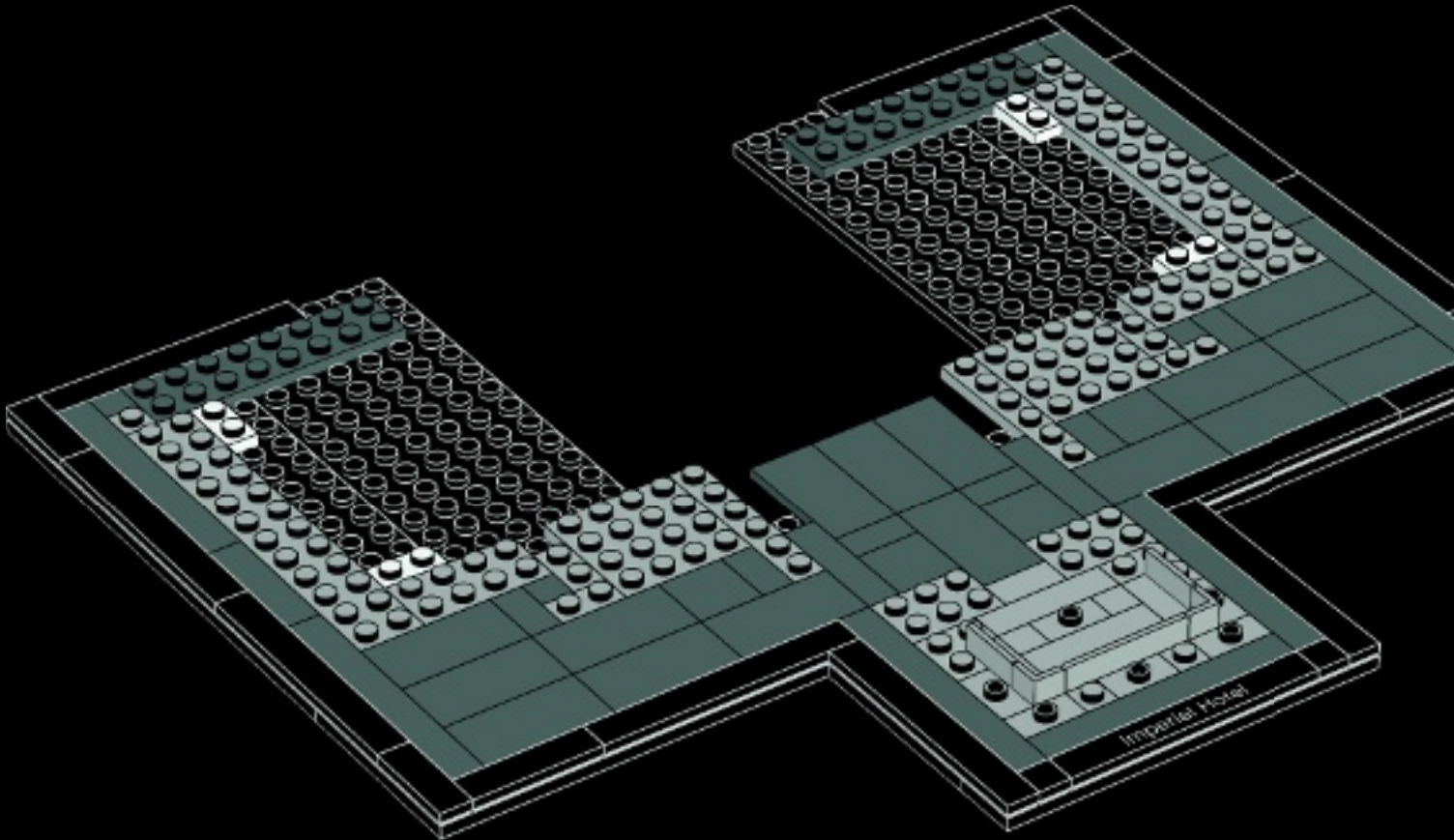

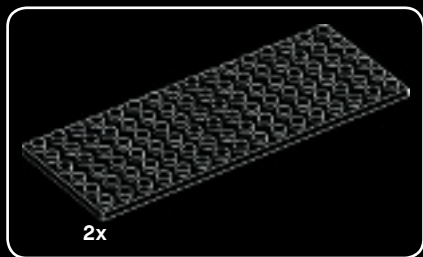

18

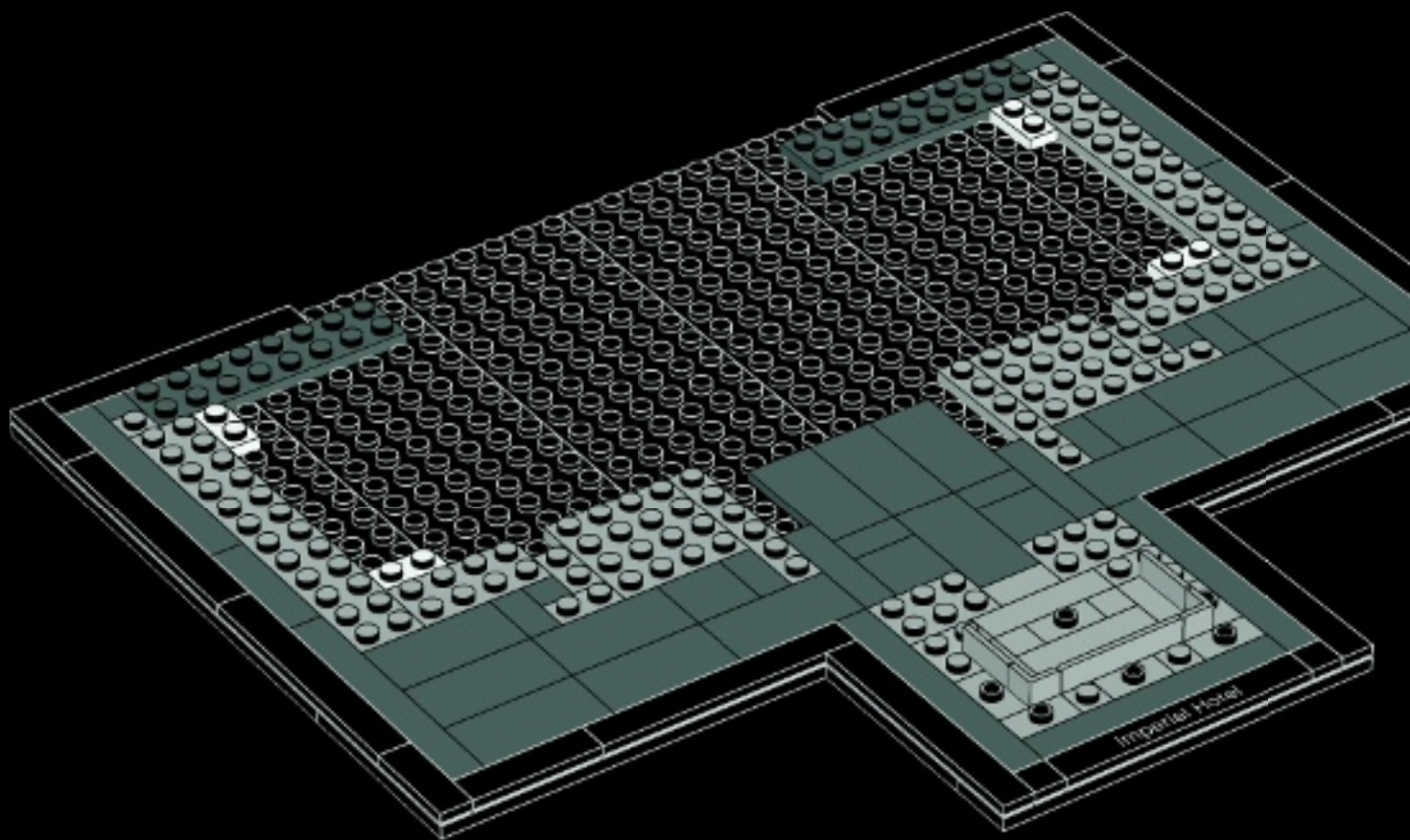

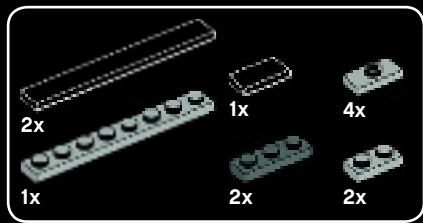

19

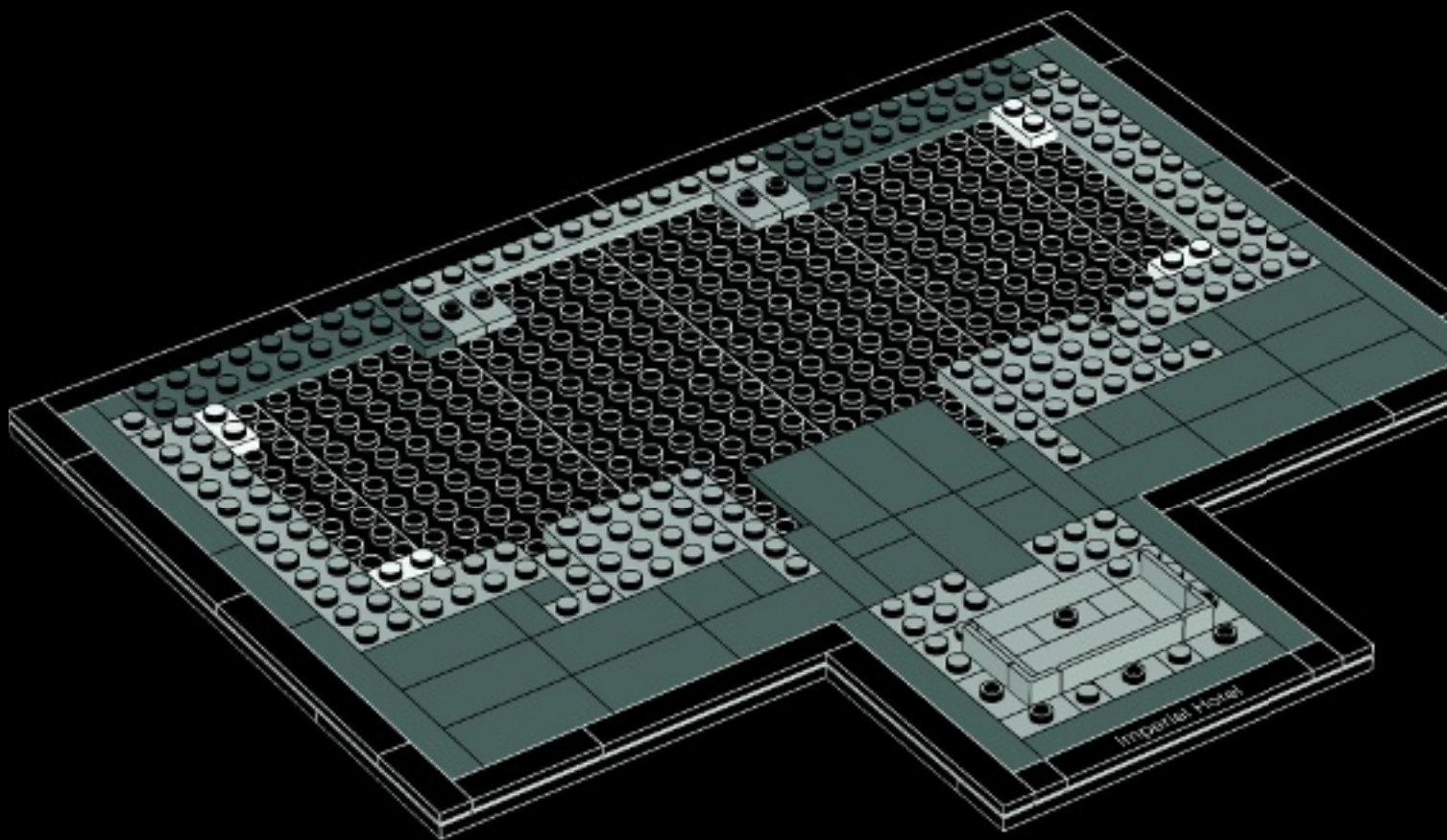

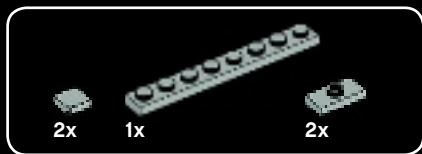

20

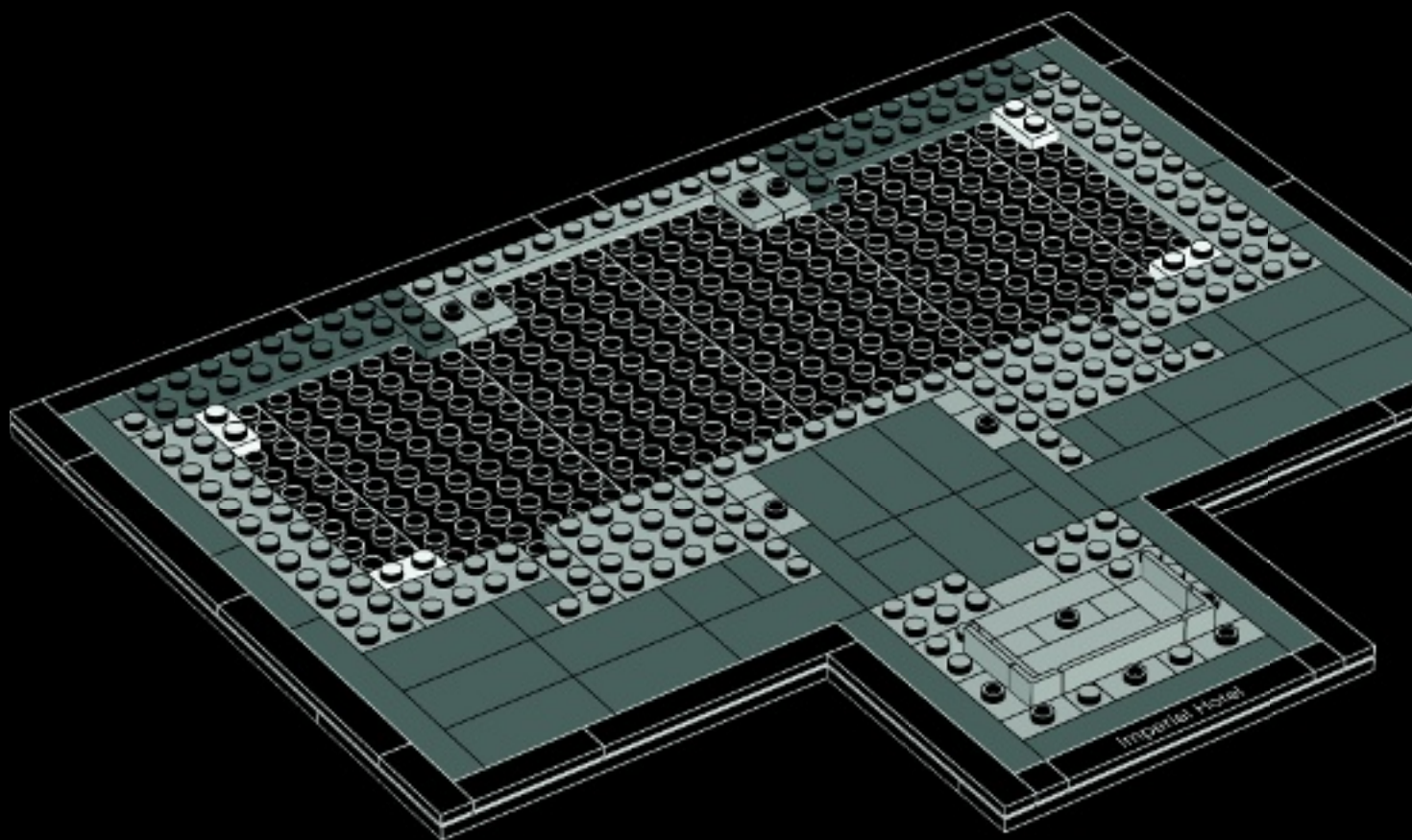



21

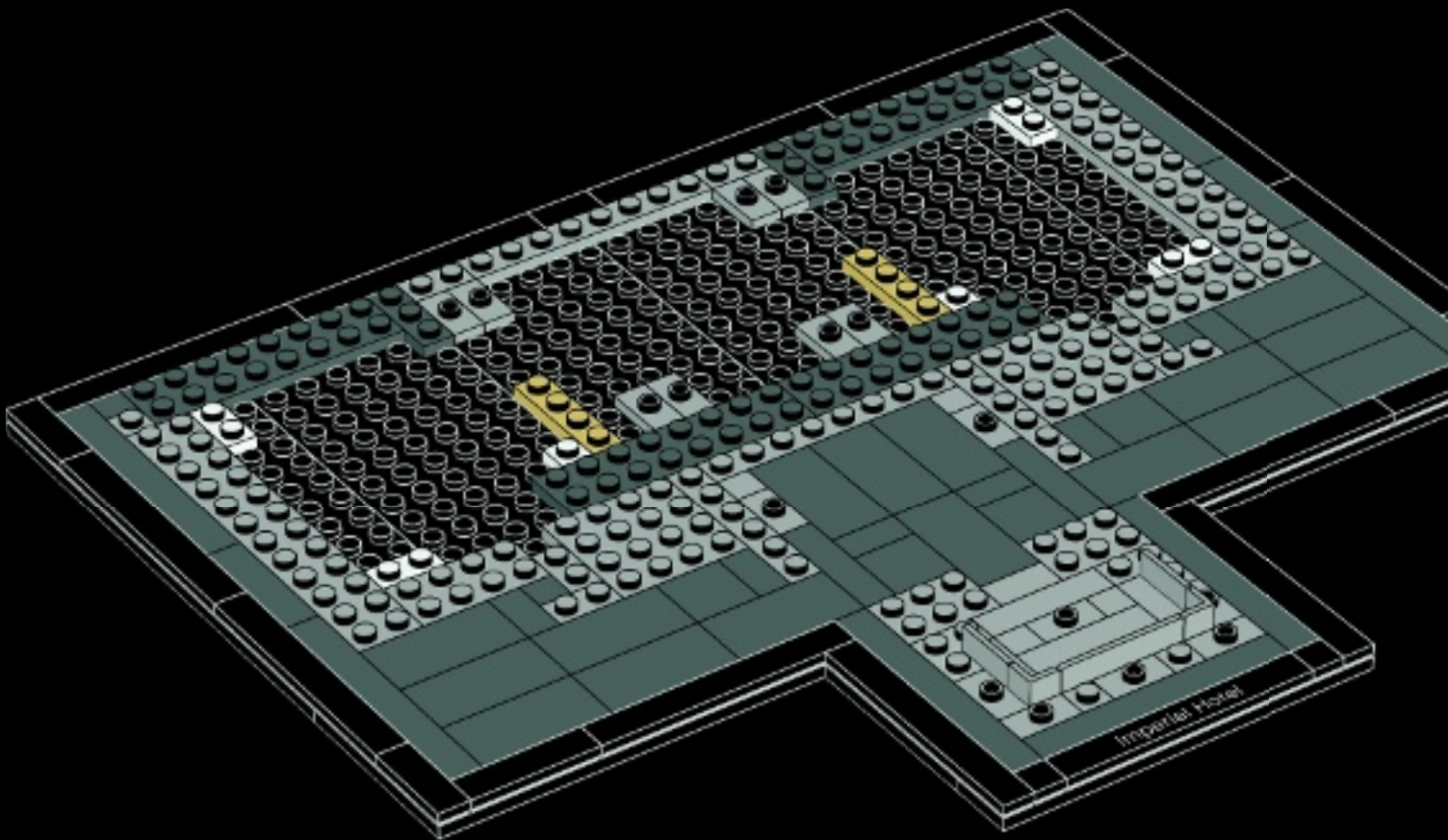

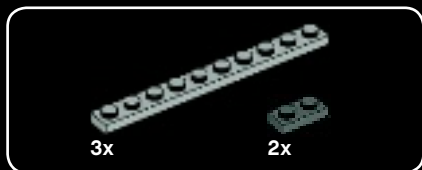

22

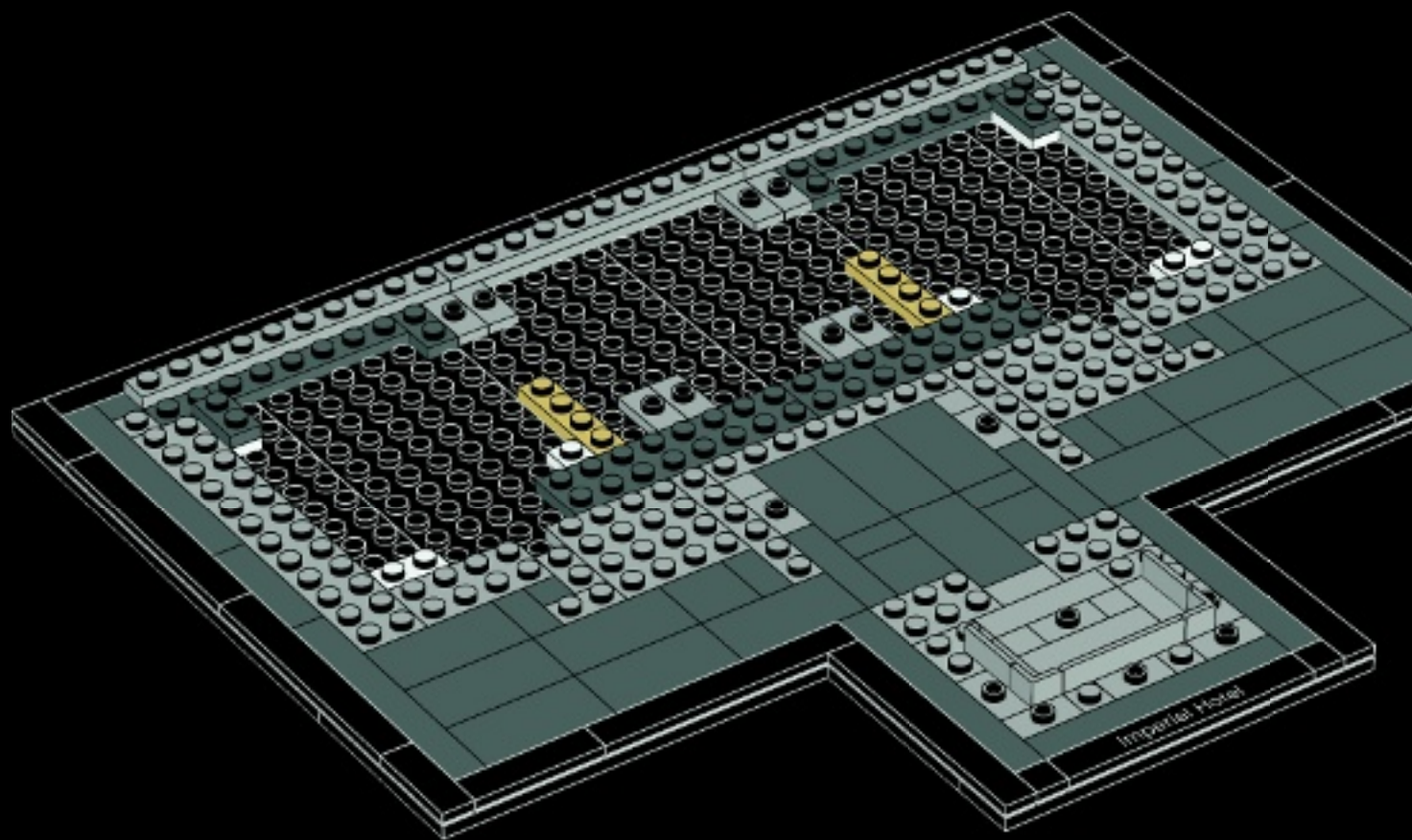

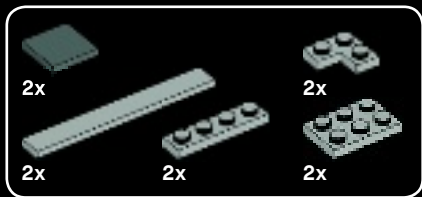

23

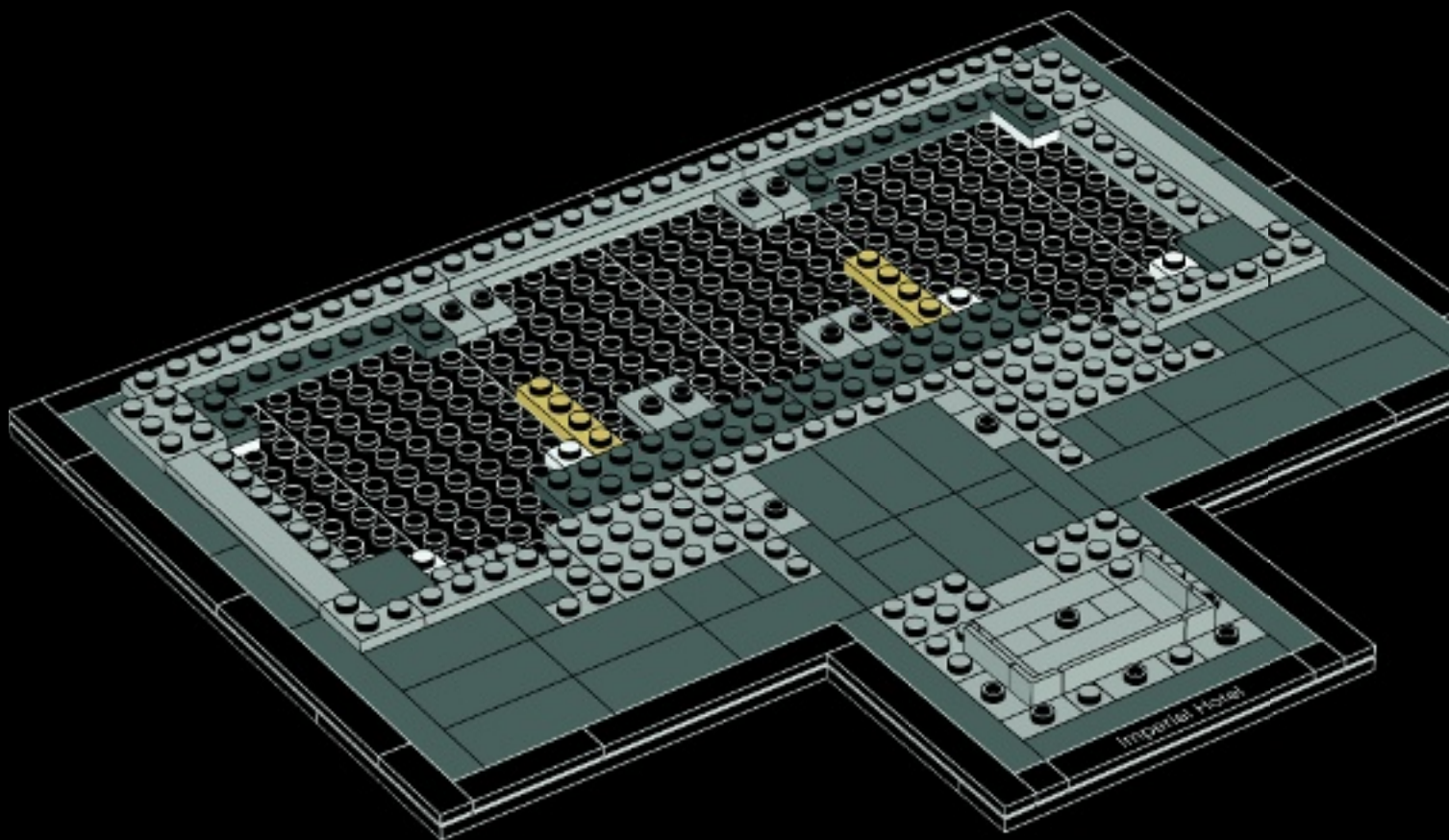



24

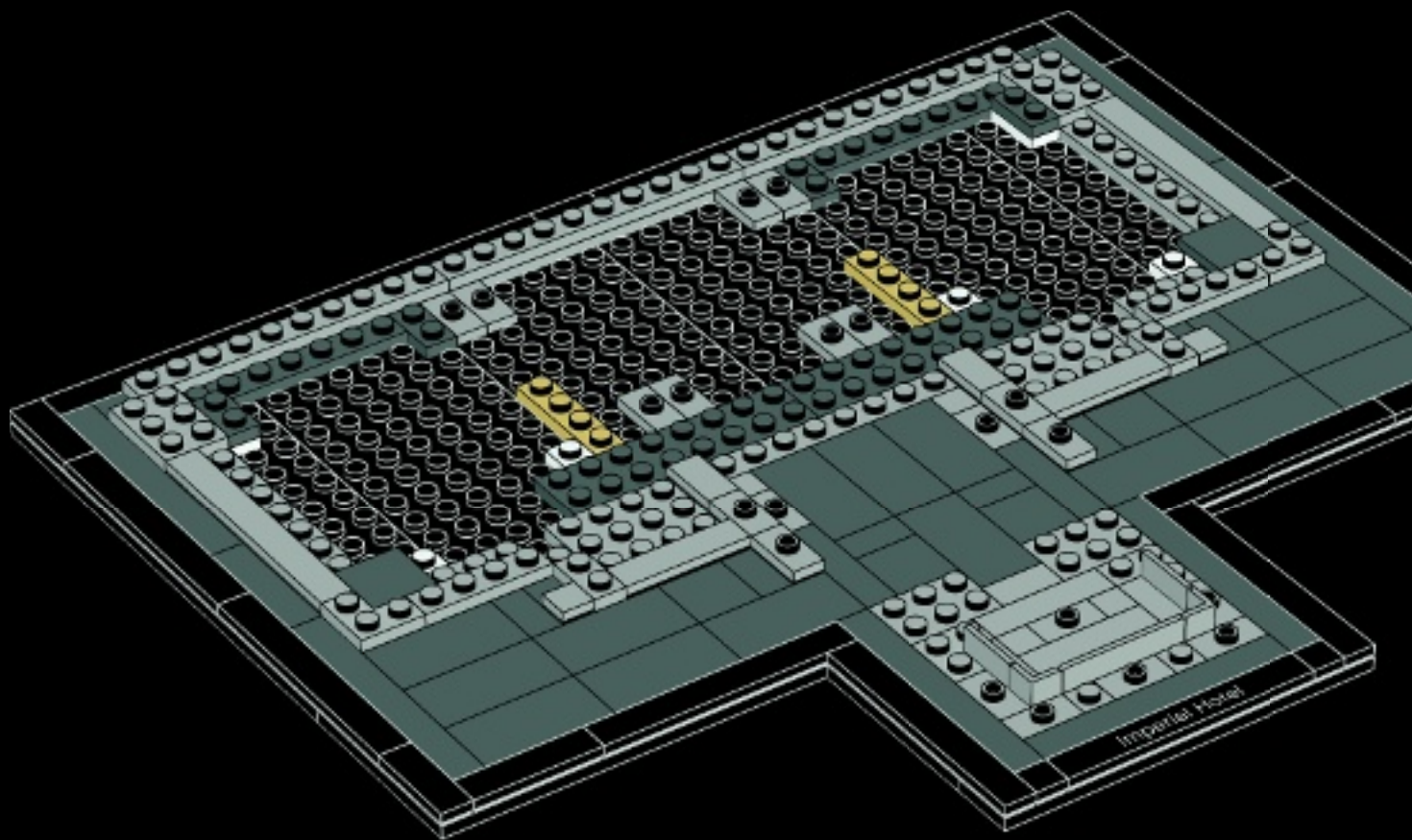



25

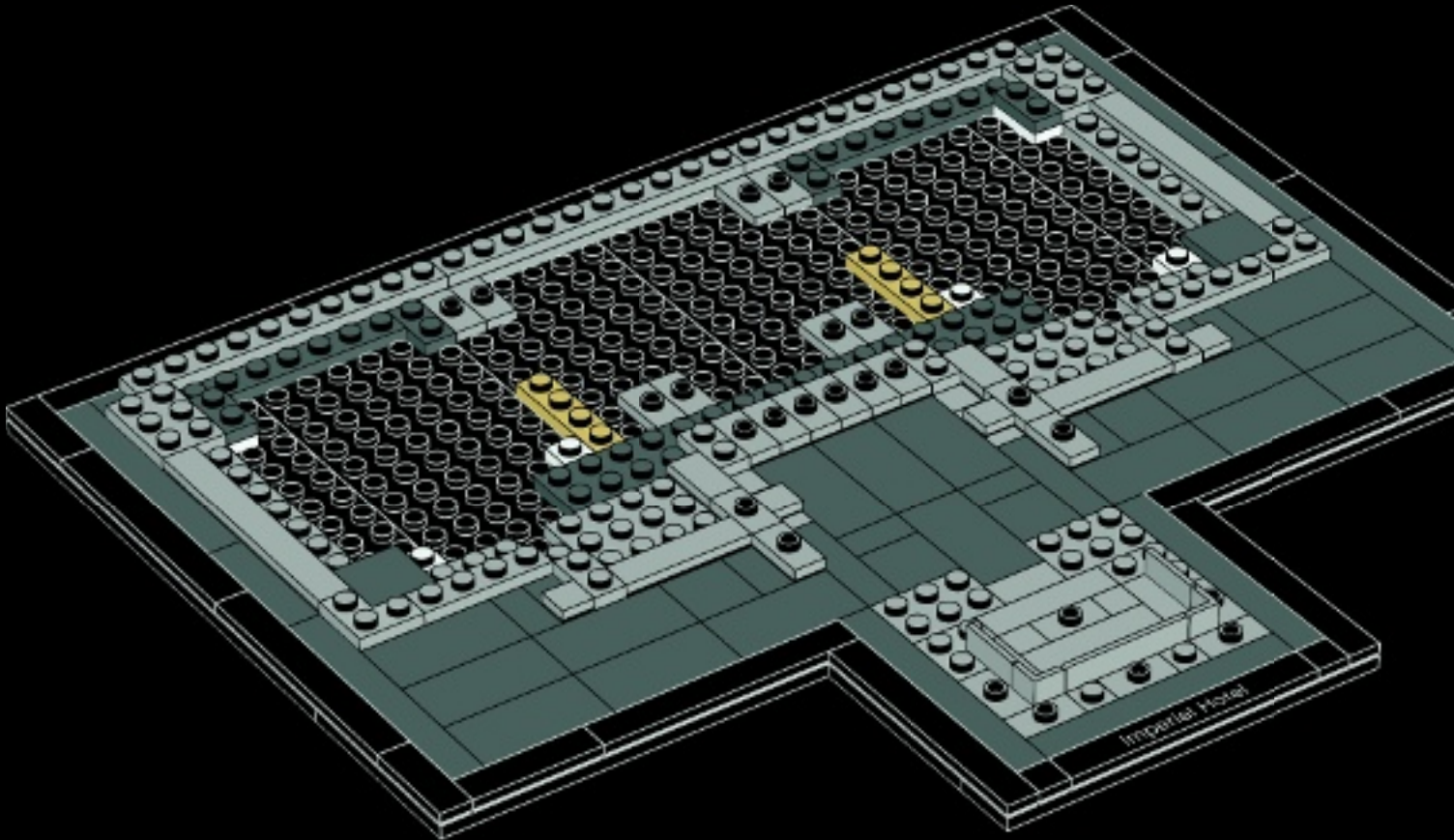

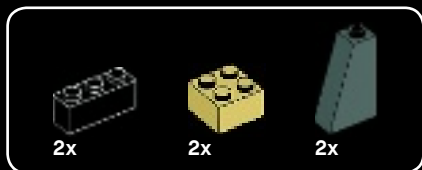

26

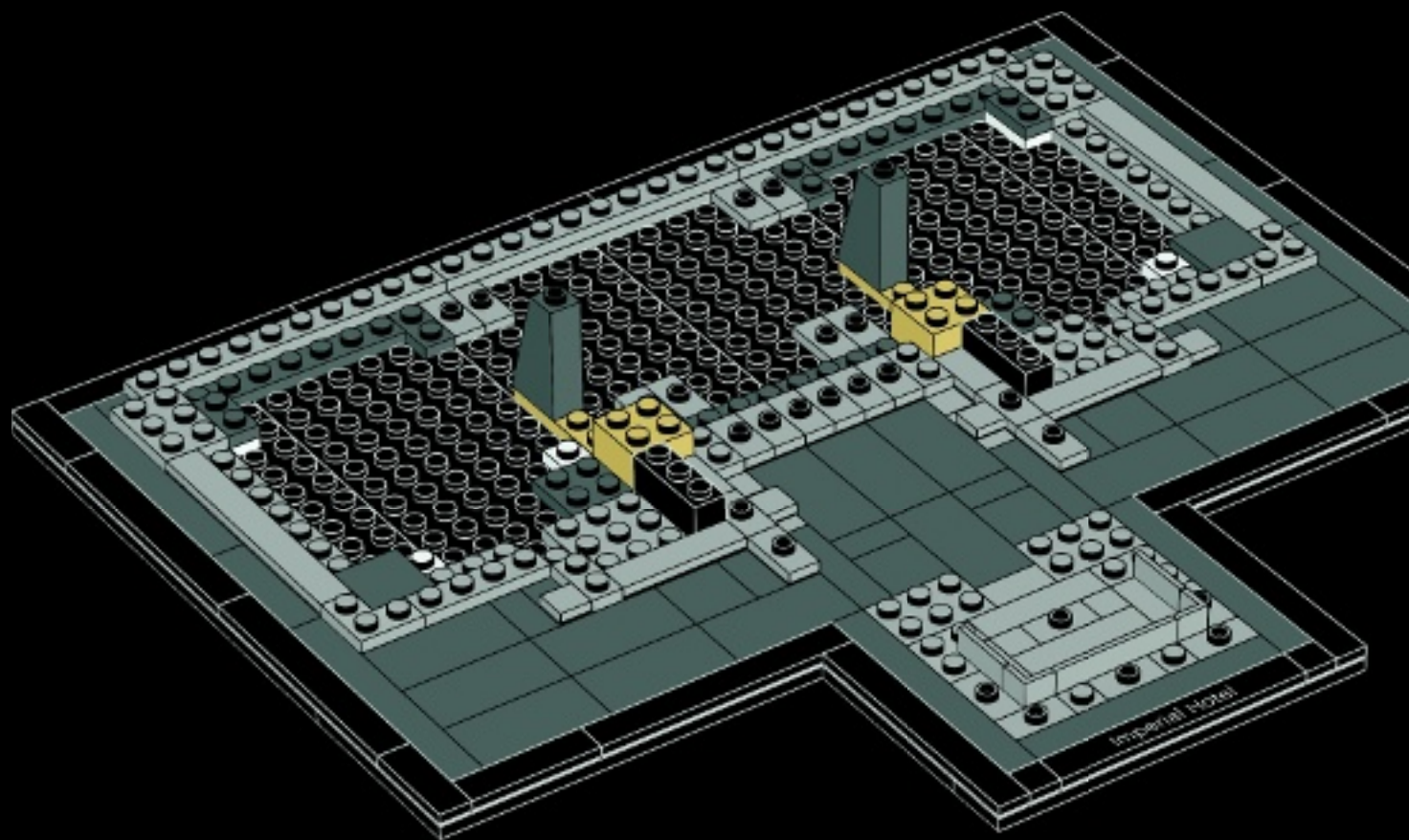



2x



4x

27

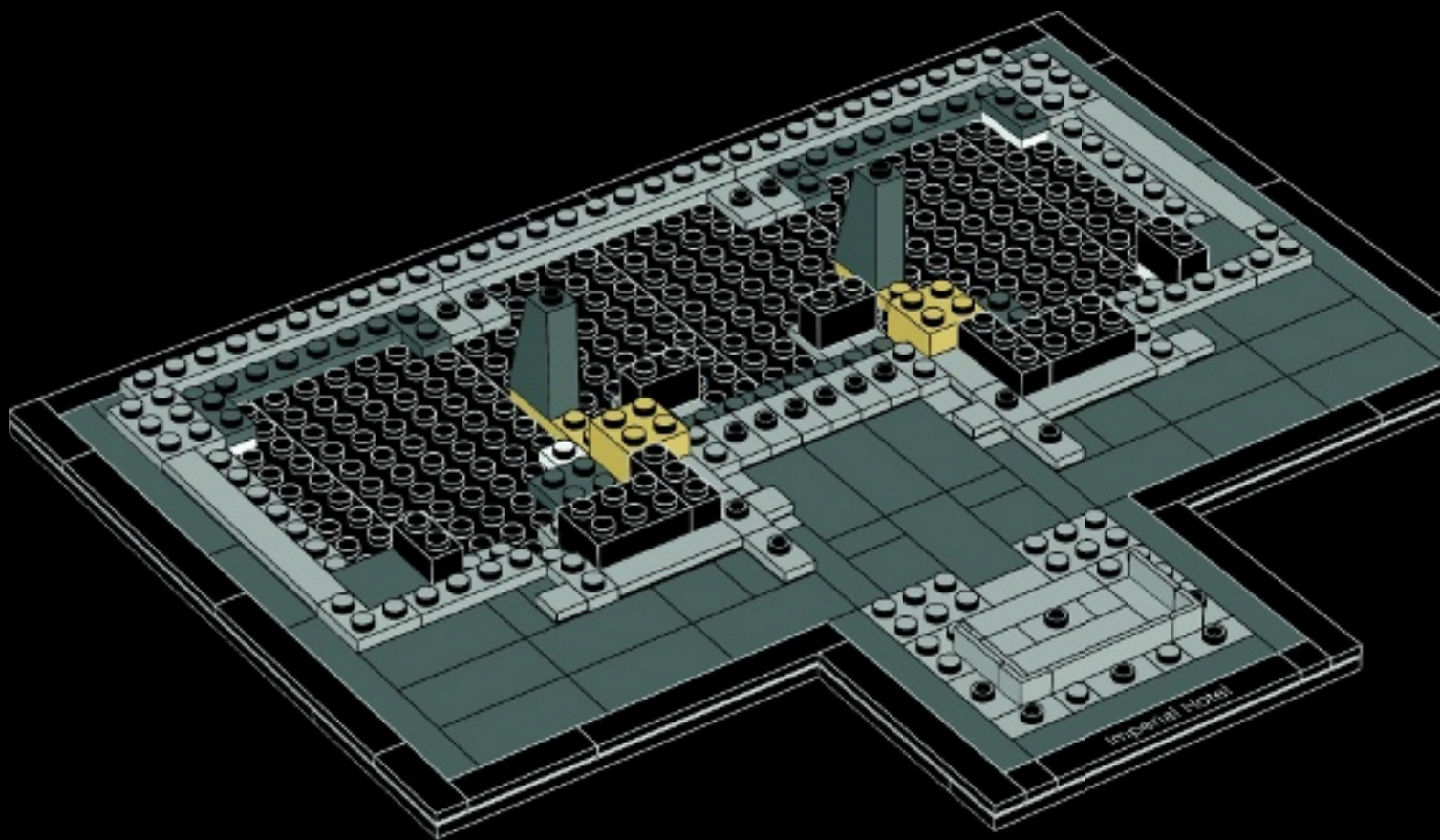



28

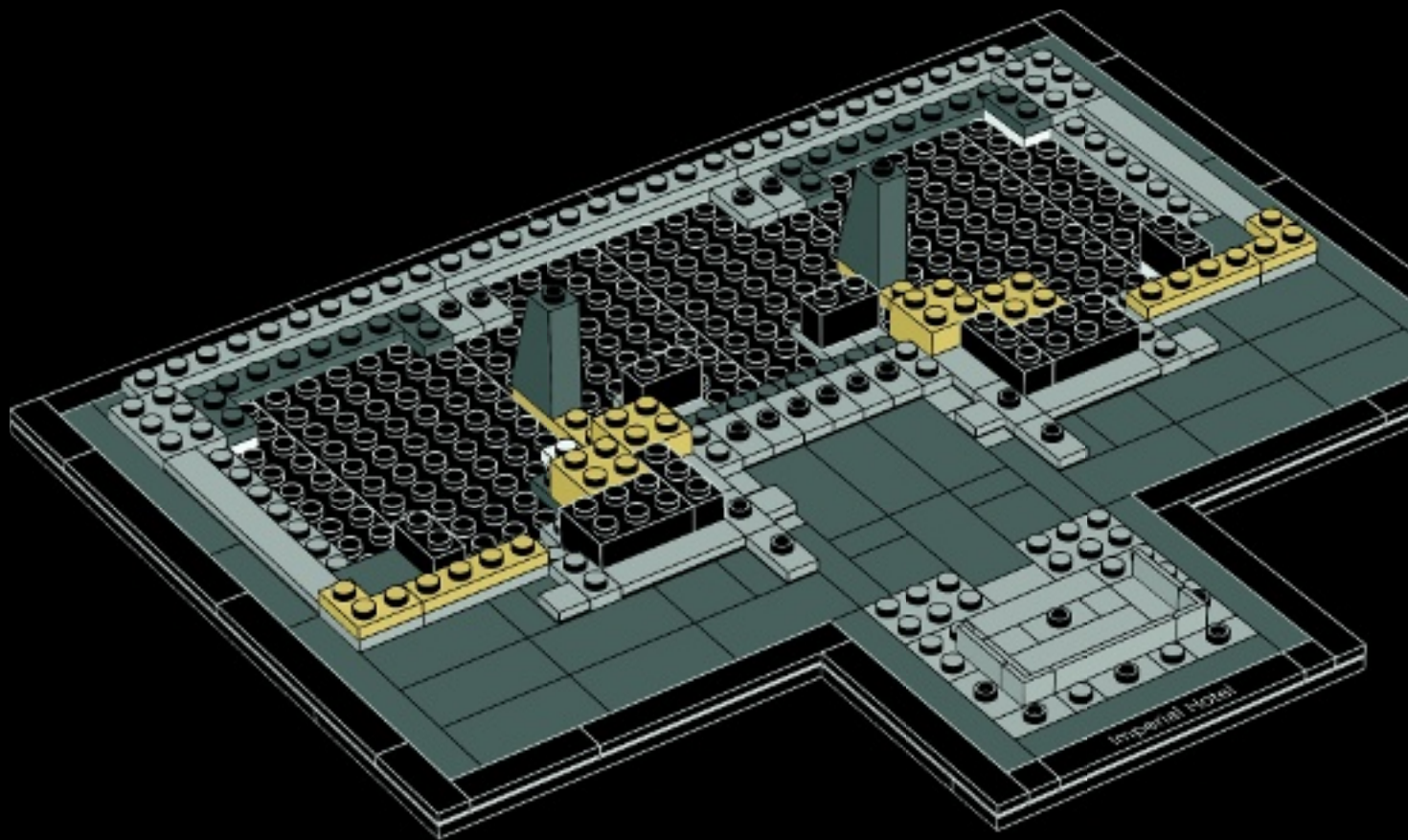



29

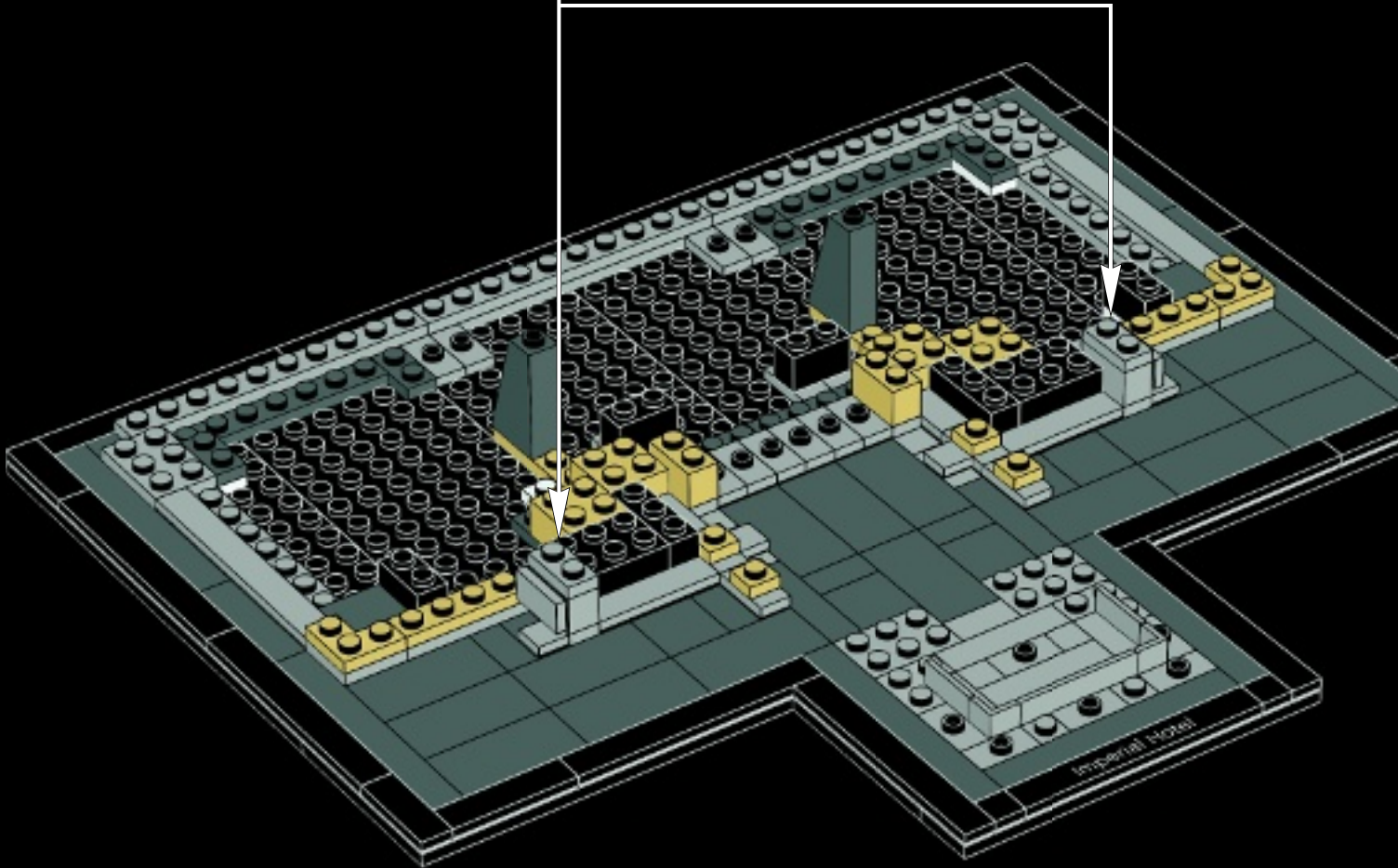
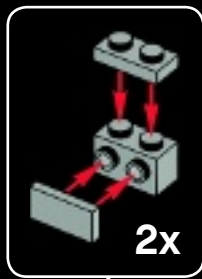



30

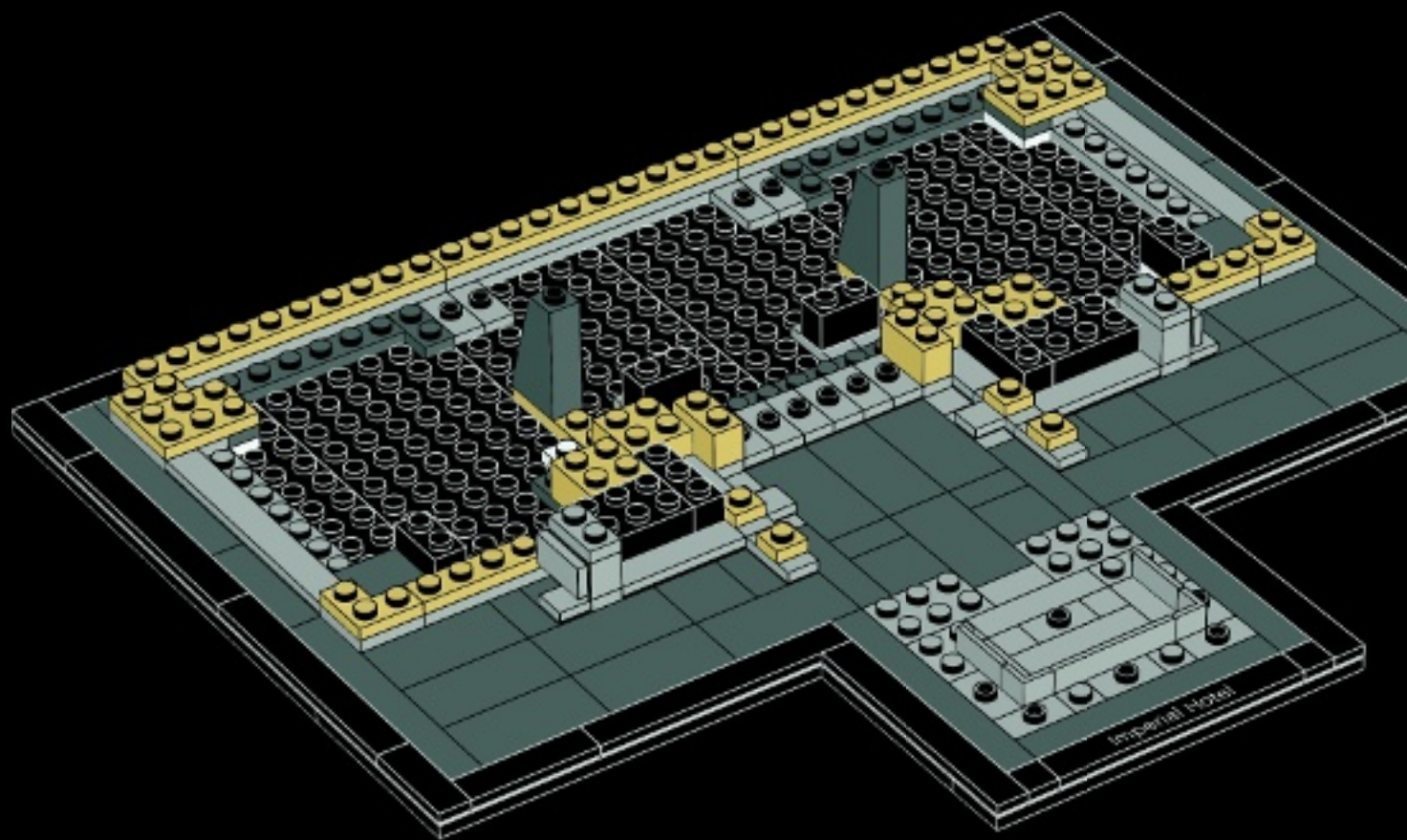

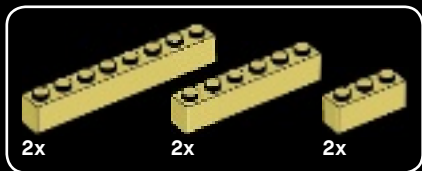

31

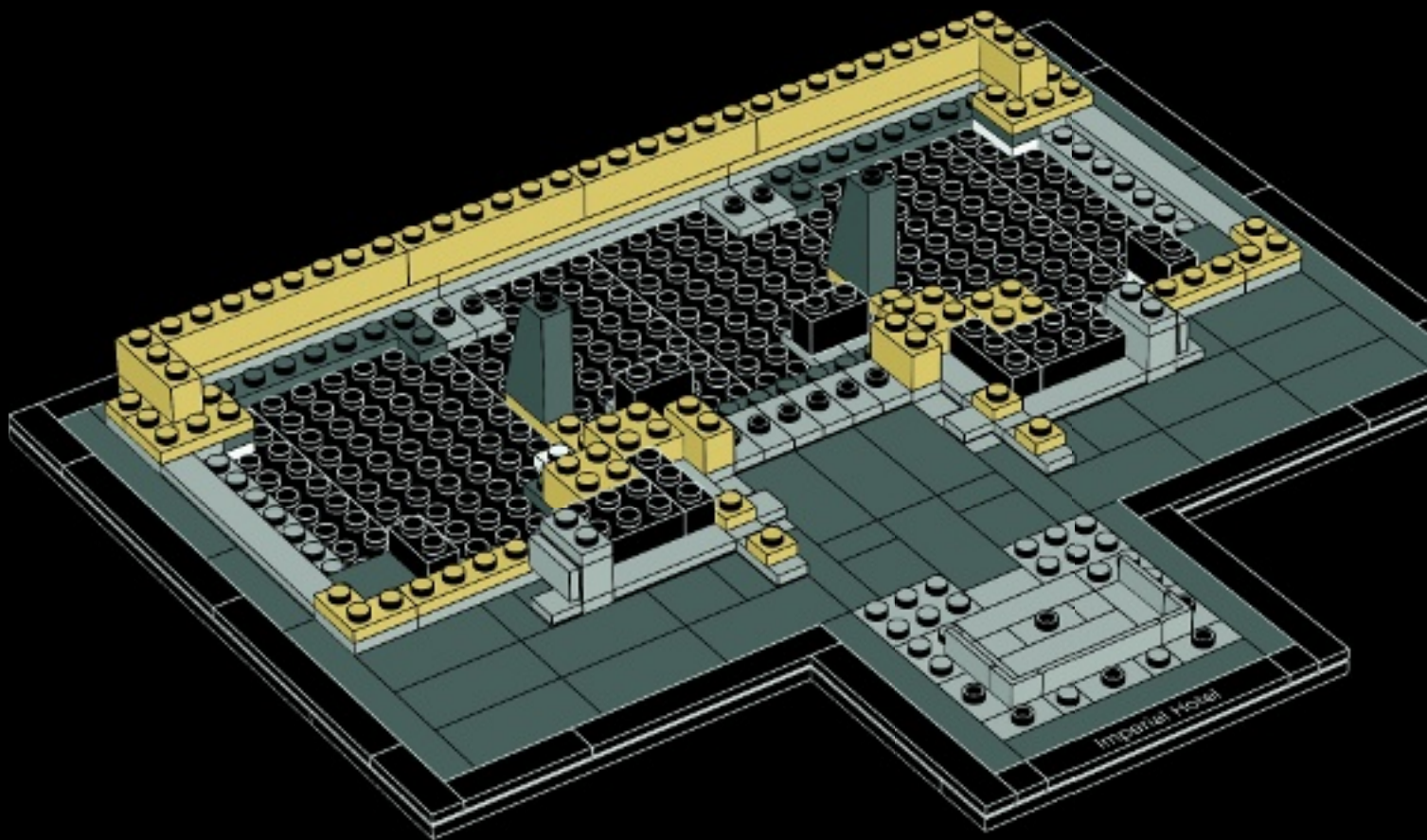



4x



2x



2x

32

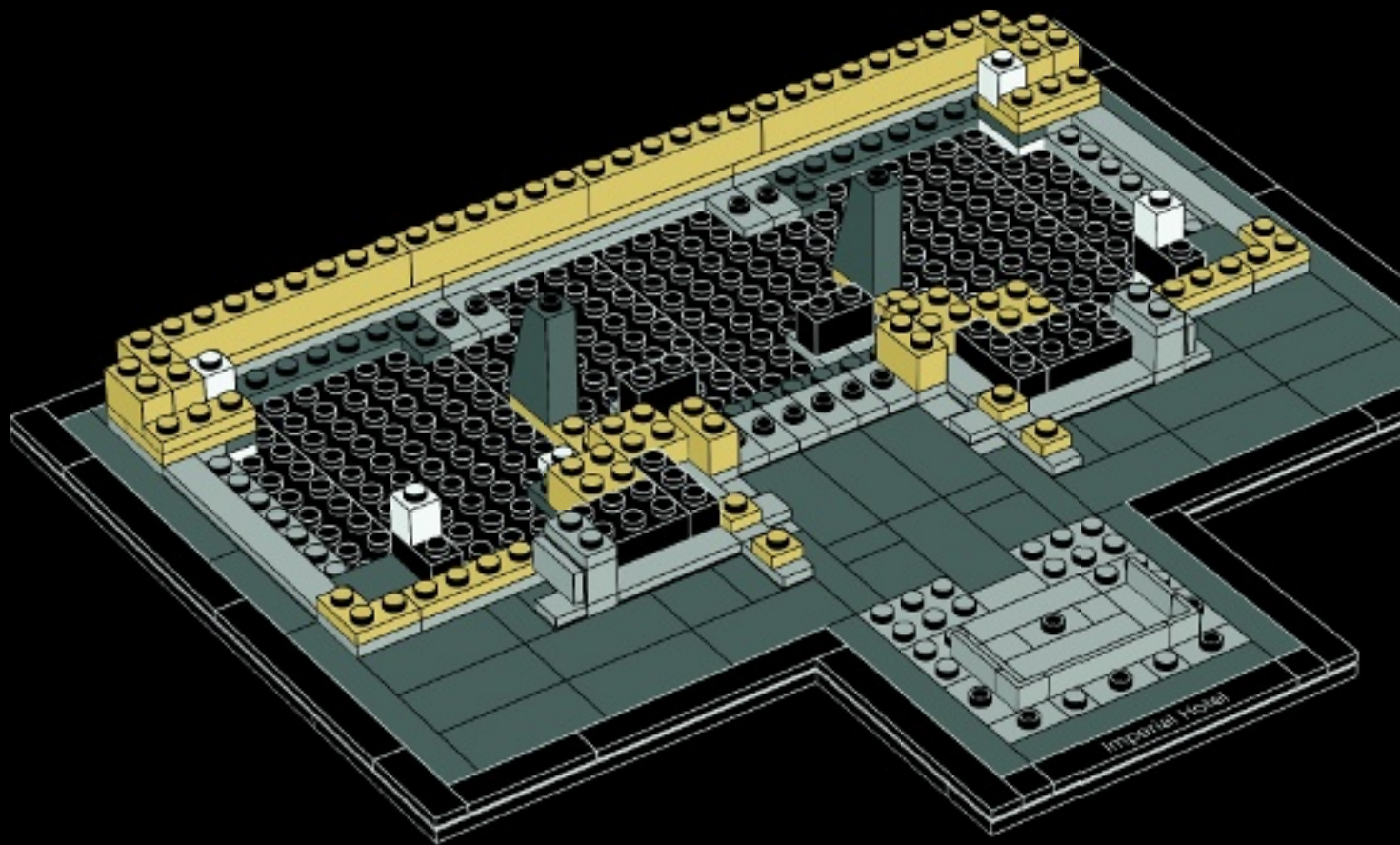

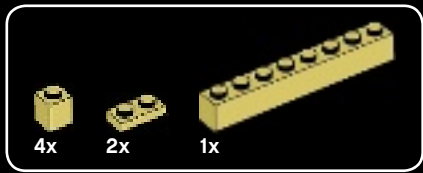

33

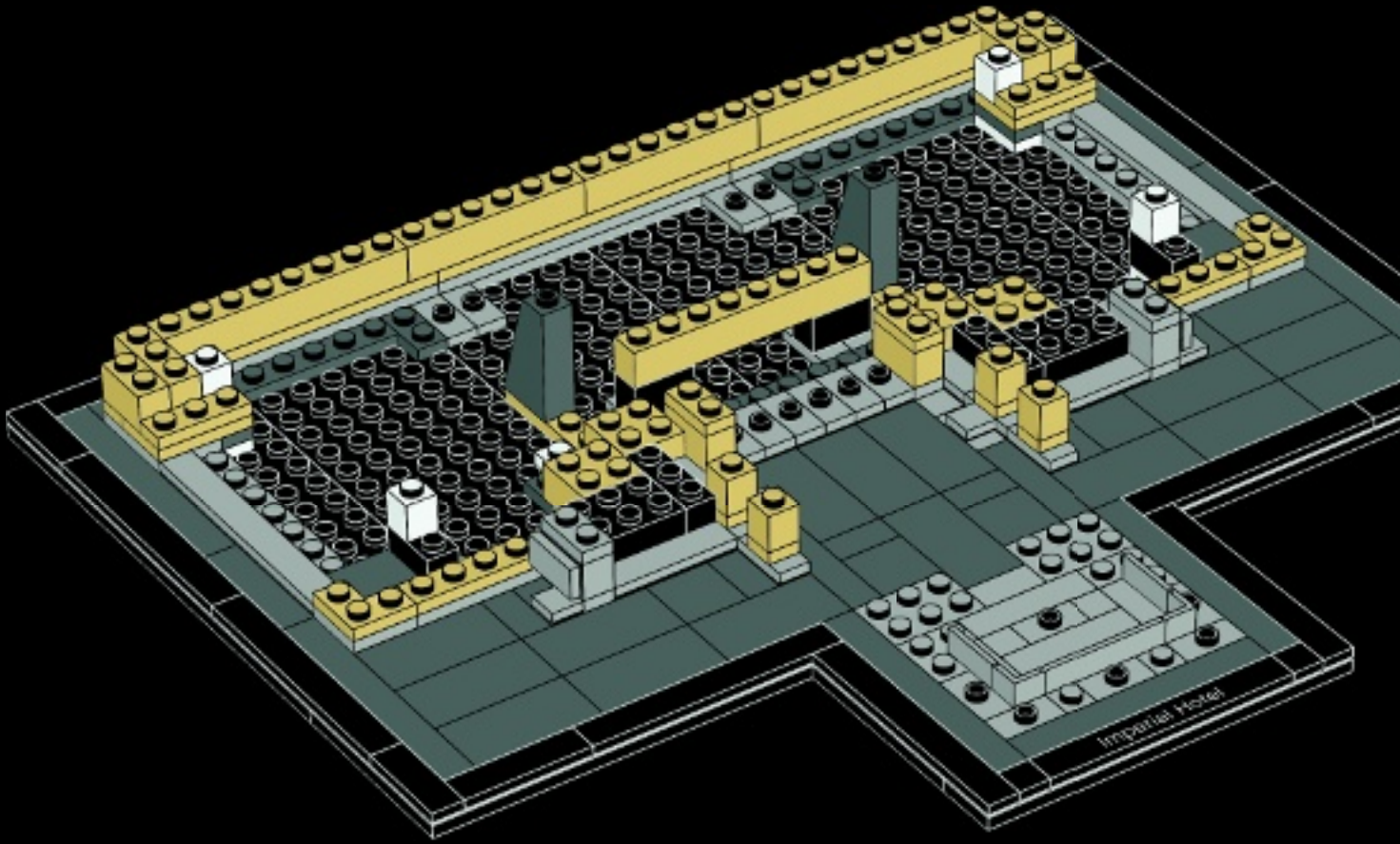



4x



6x

34

1



2



3



2x

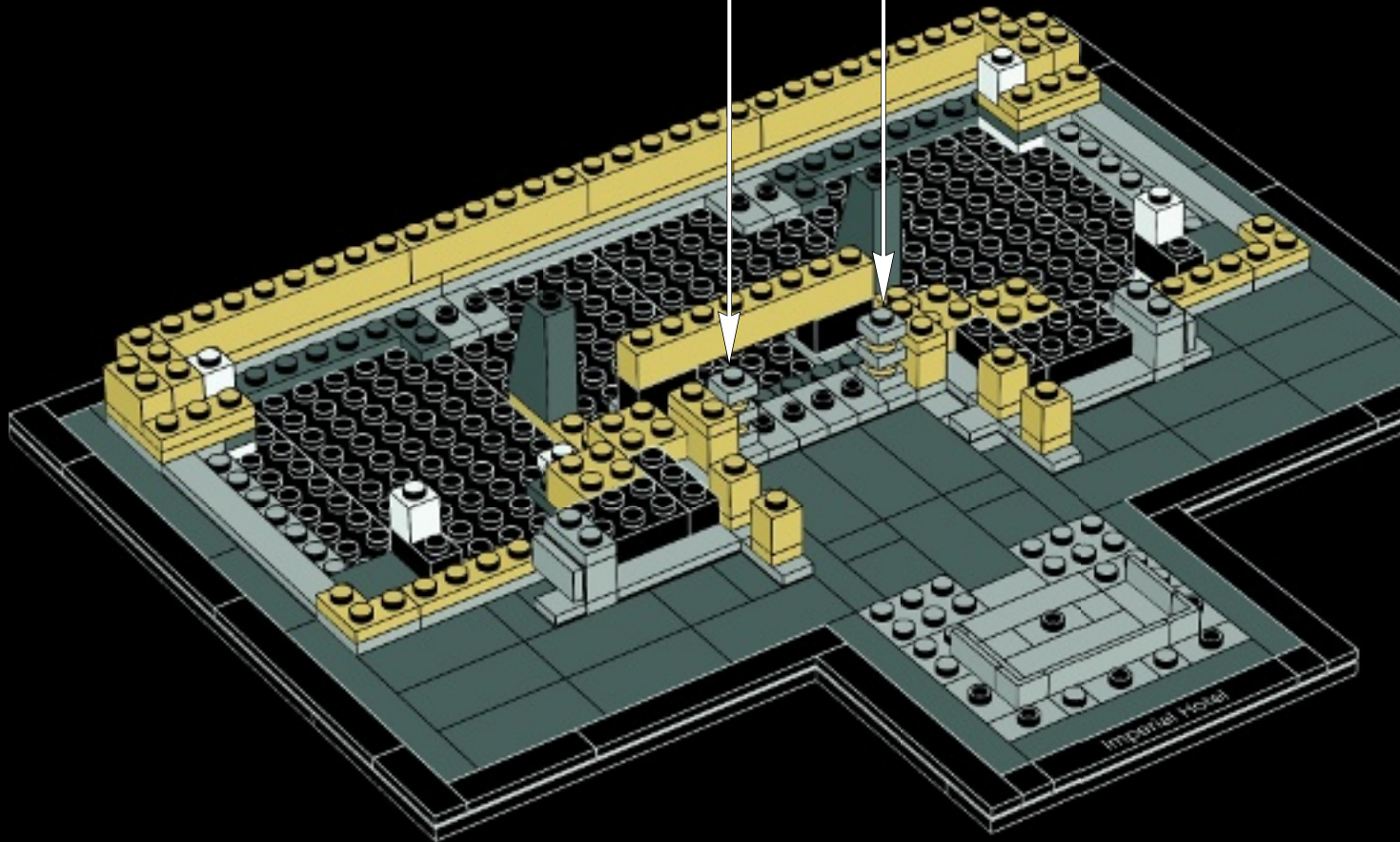



10x

35

1



2



2x

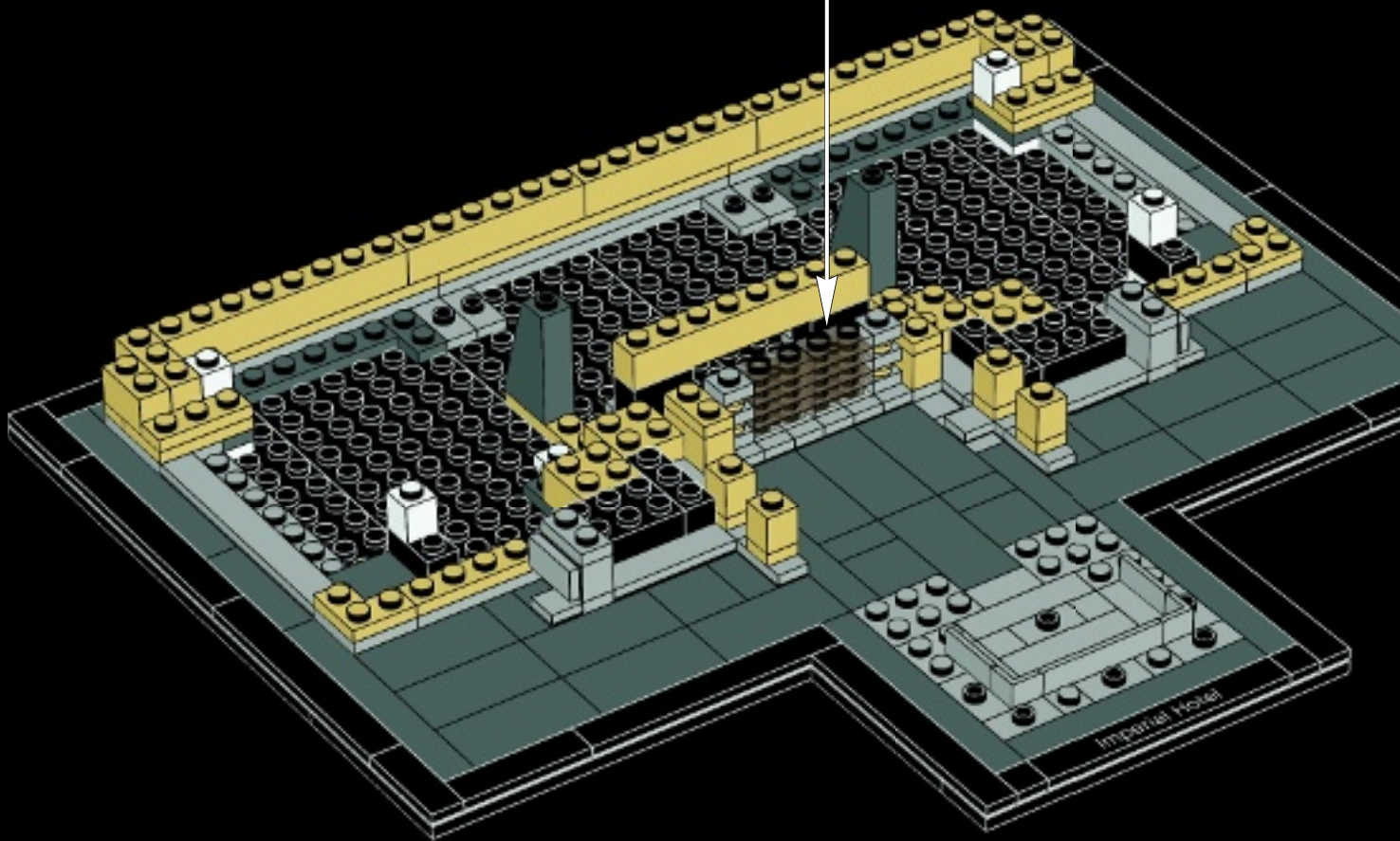

Imperial House



36

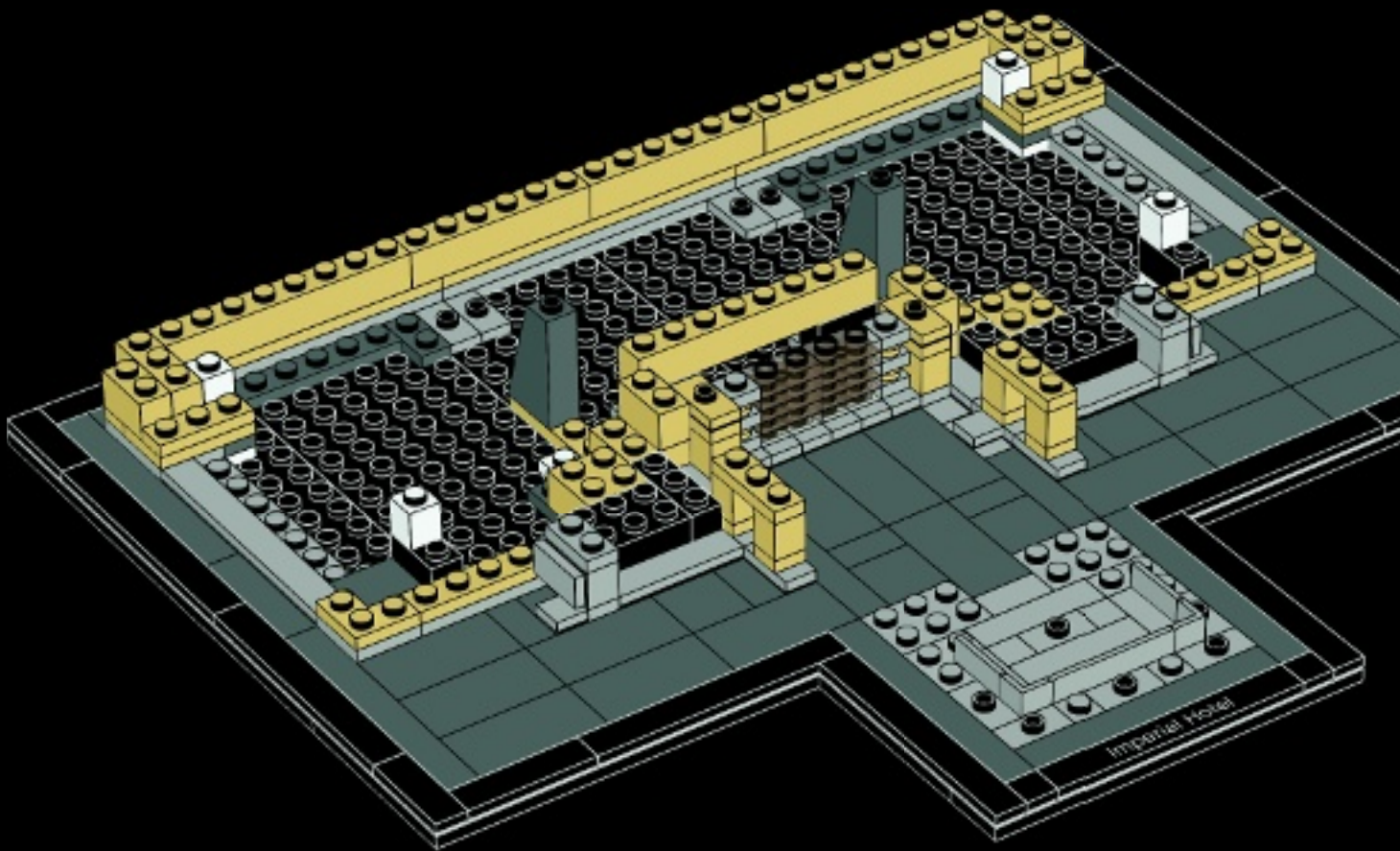



2x



2x

37

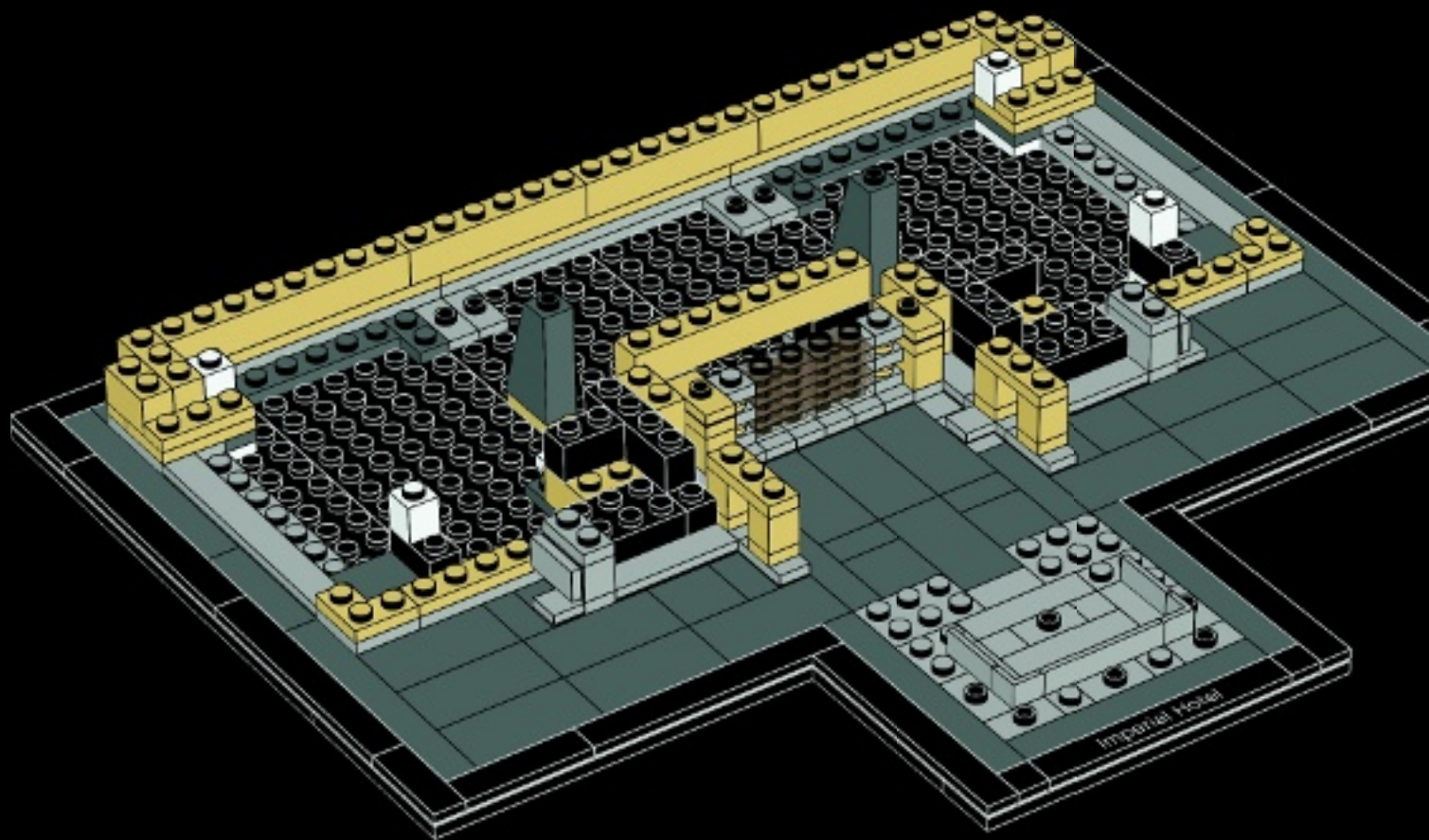



38

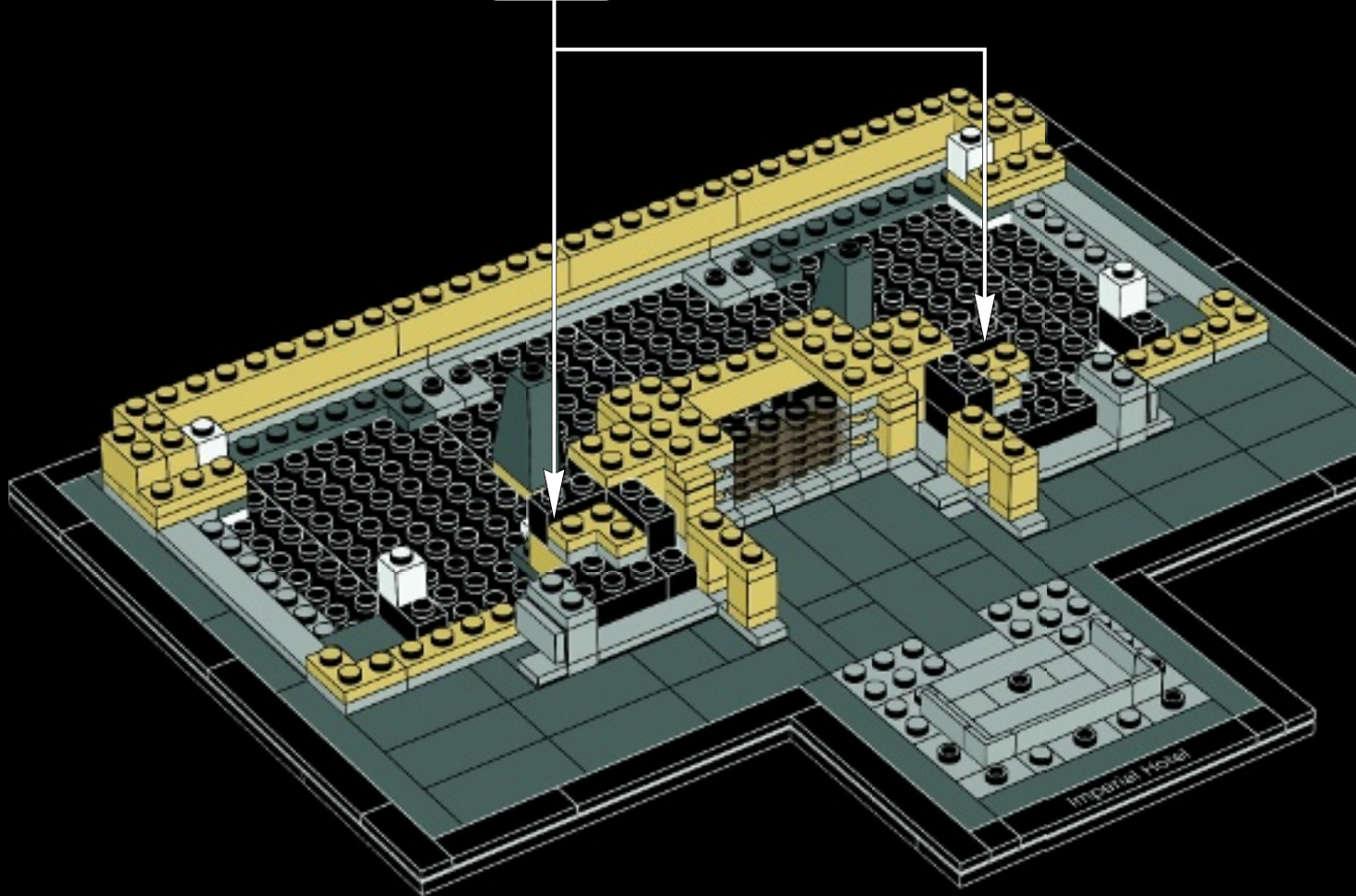



39

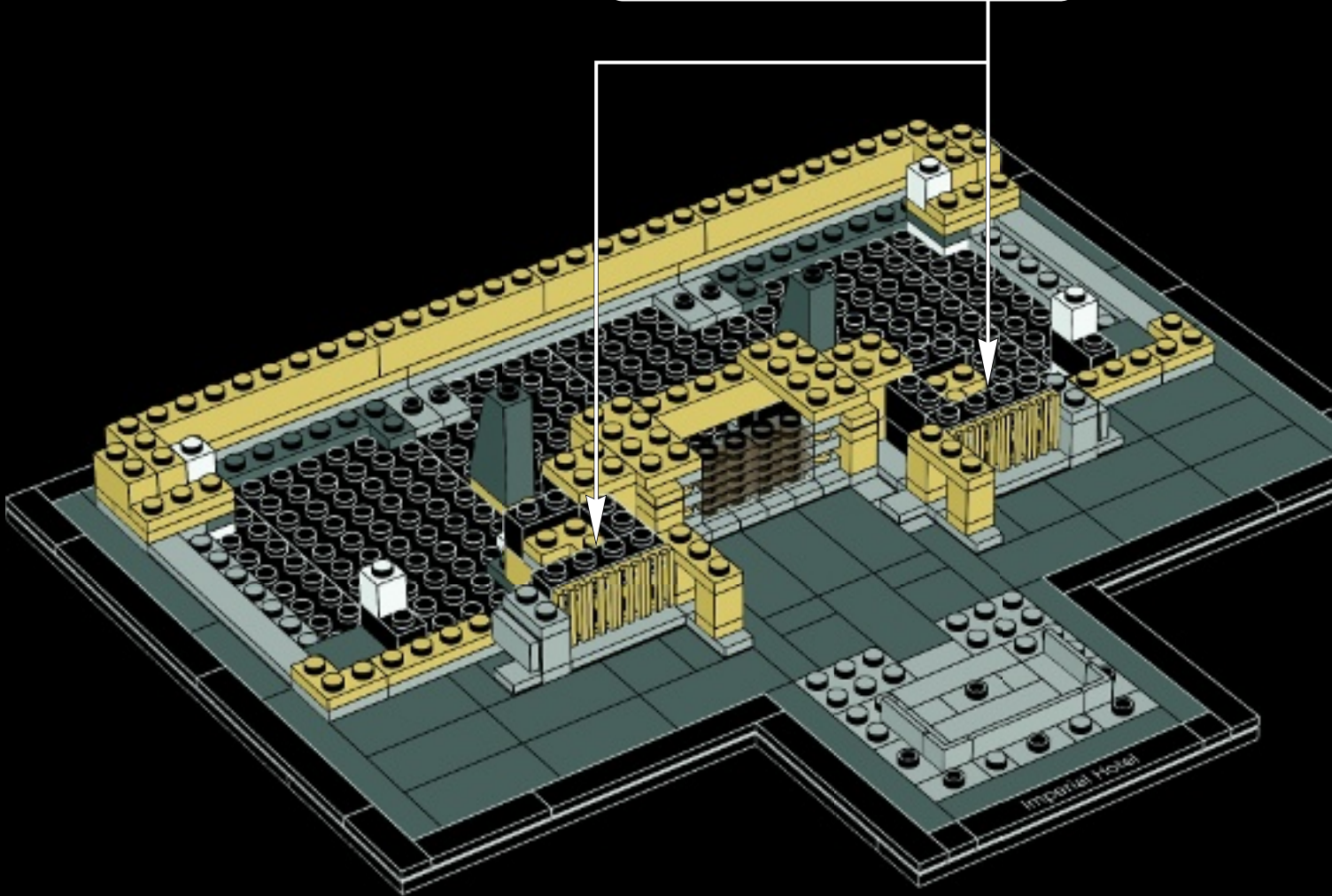
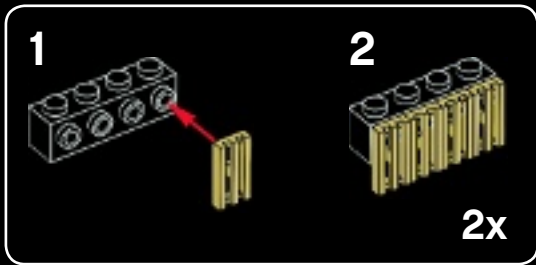



2x



2x

40

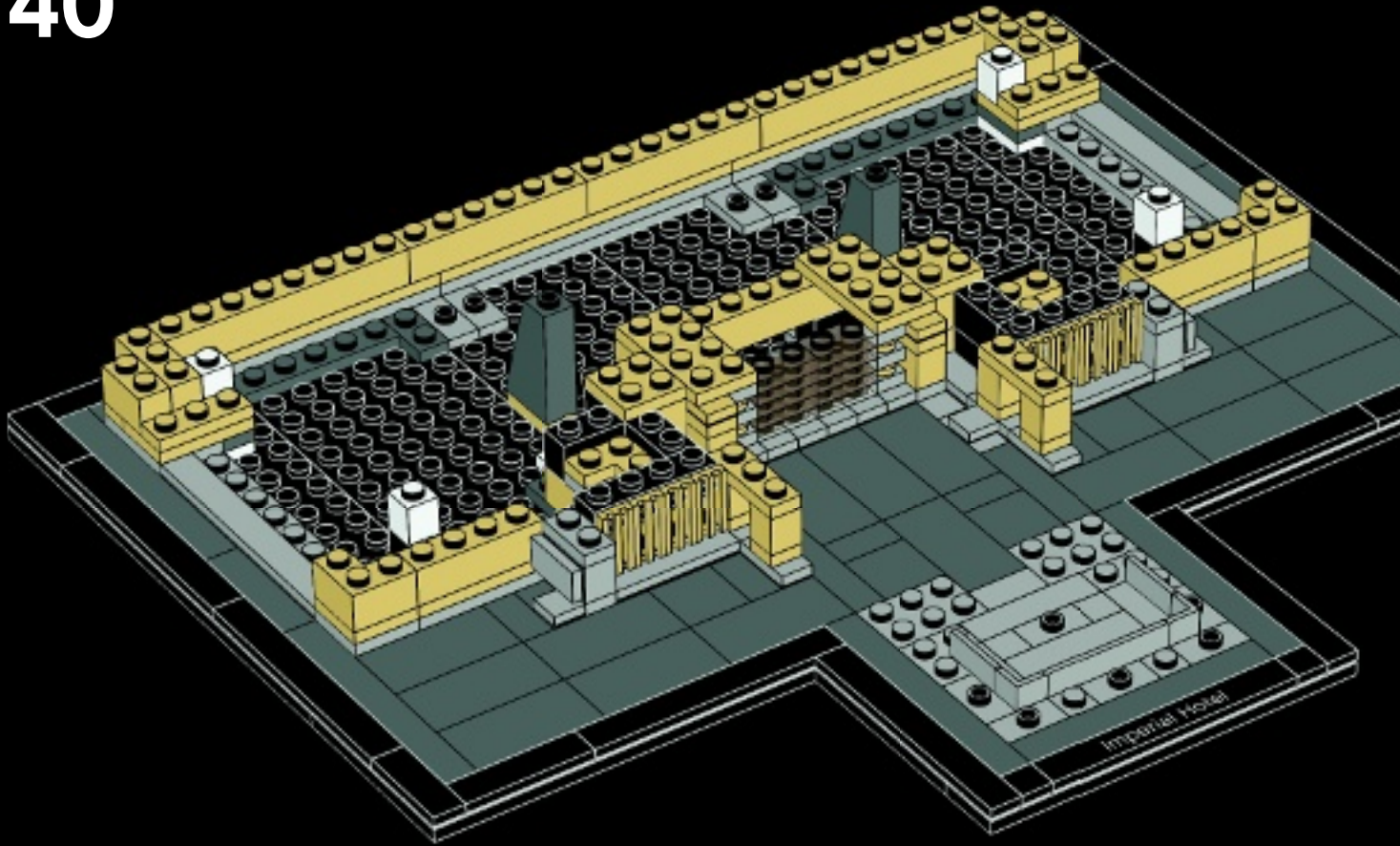

Wright designed a shallow pool outside the lobby that could provide a source of water for fighting the fire-storms that occurred after an earthquake.

Wright dessina une piscine peu profonde devant le hall qui pouvait fournir de l'eau pour lutter contre les incendies qui se produisaient après un tremblement de terre.



© Ayuko Yonozu

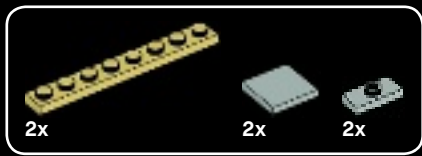

41

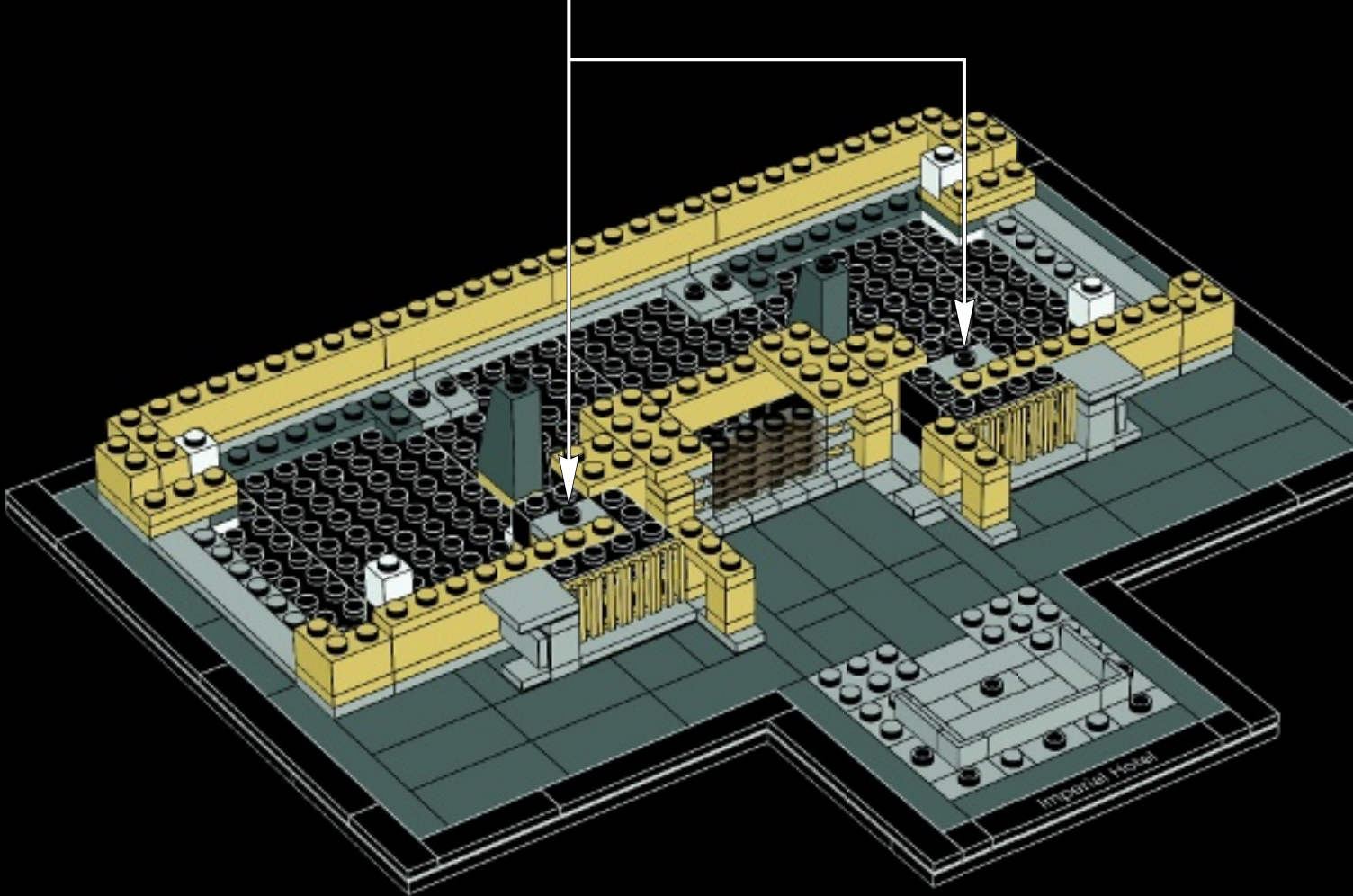

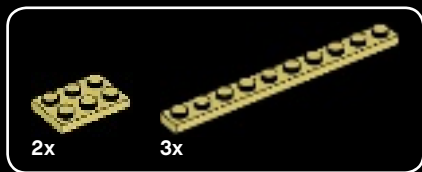

42

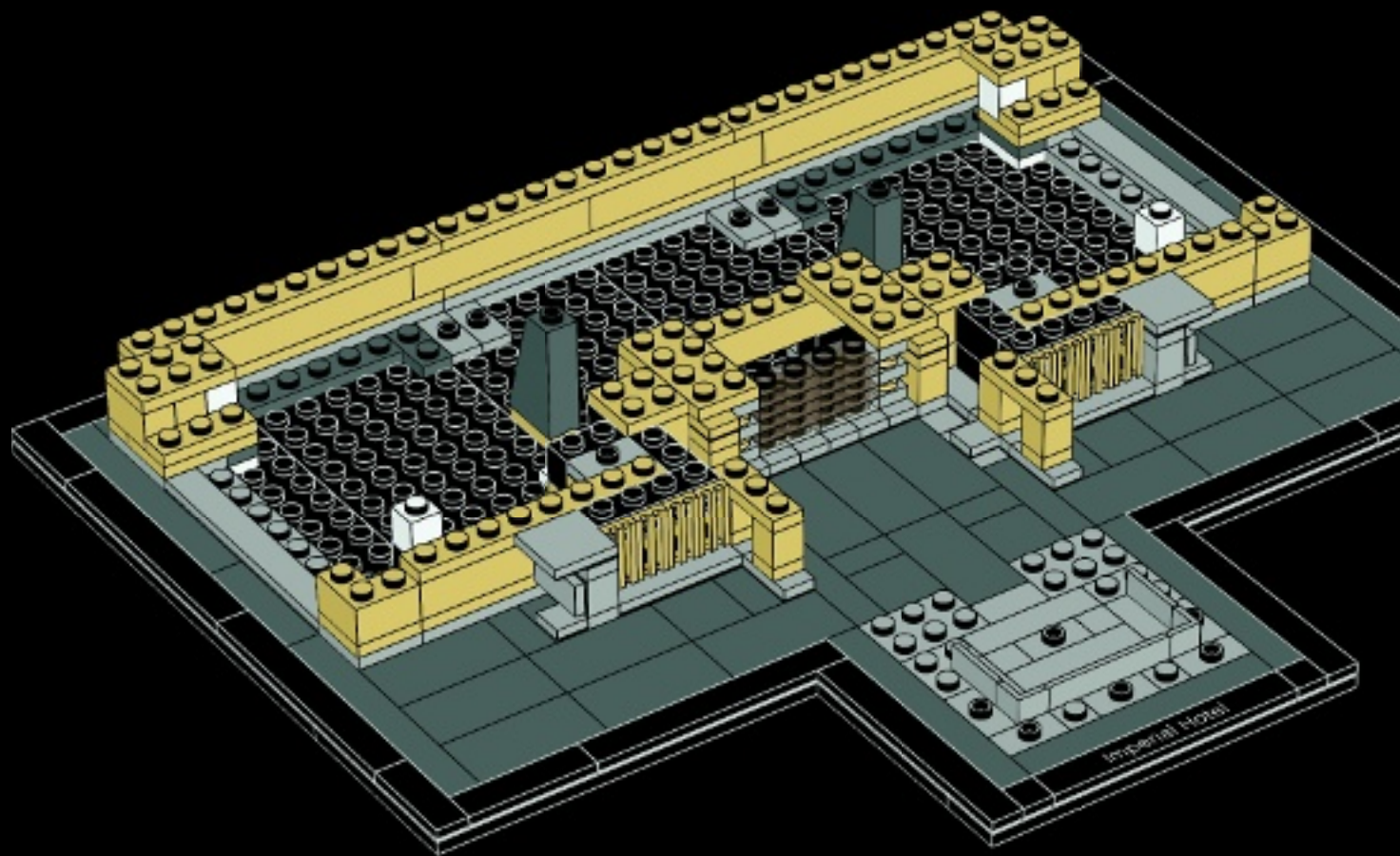



1

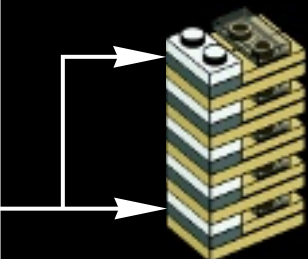
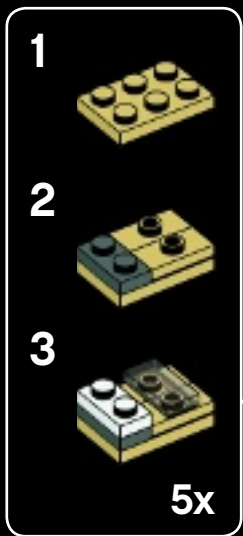

2





3



4

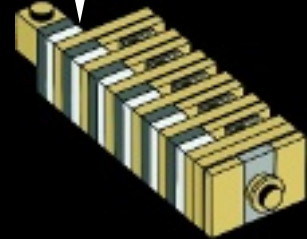
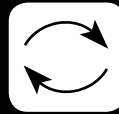
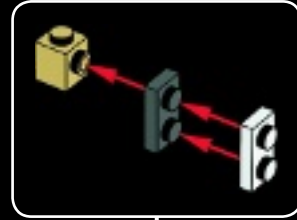

43

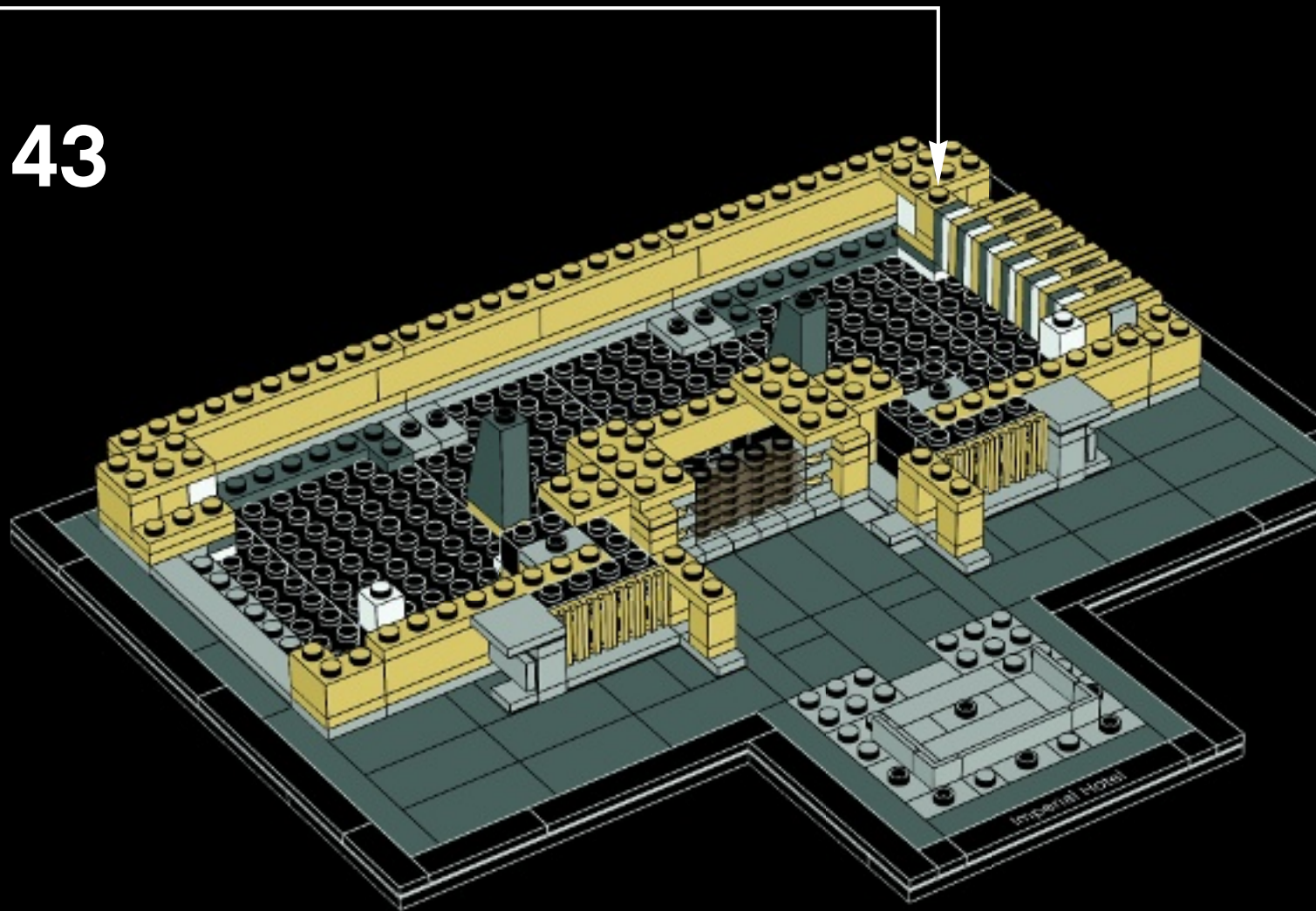



1

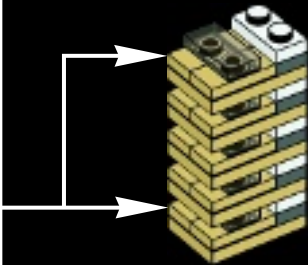
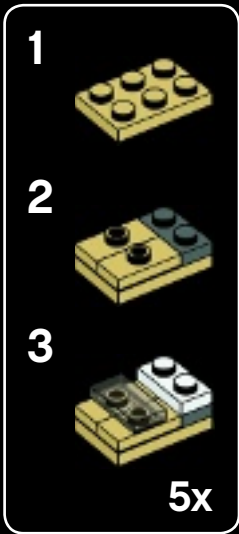

2





3



4

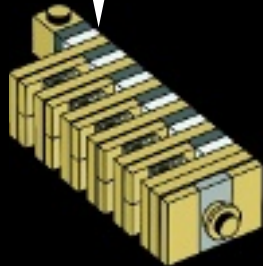
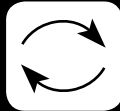
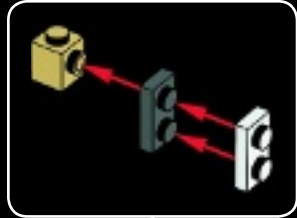

44

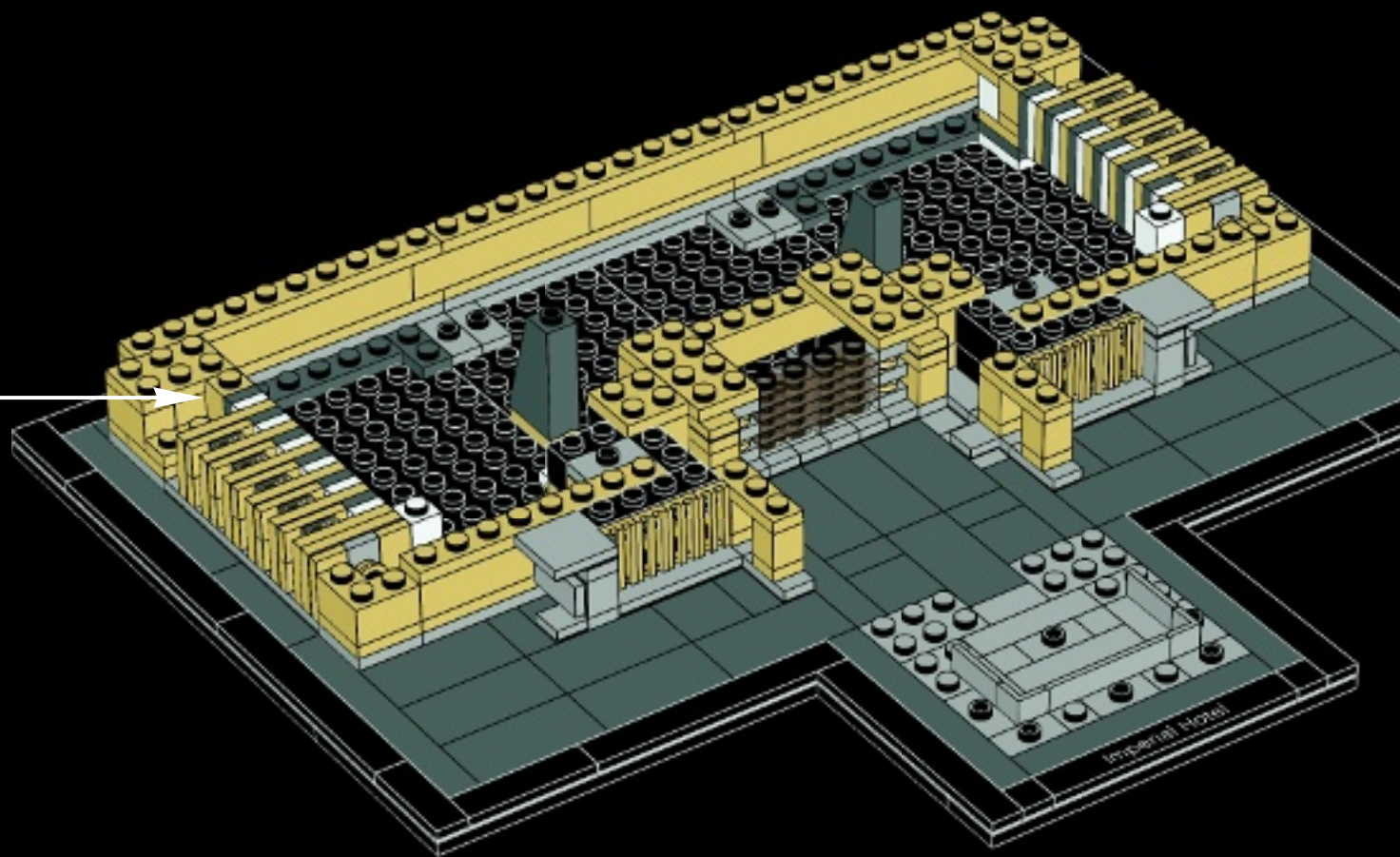



2x



2x

45

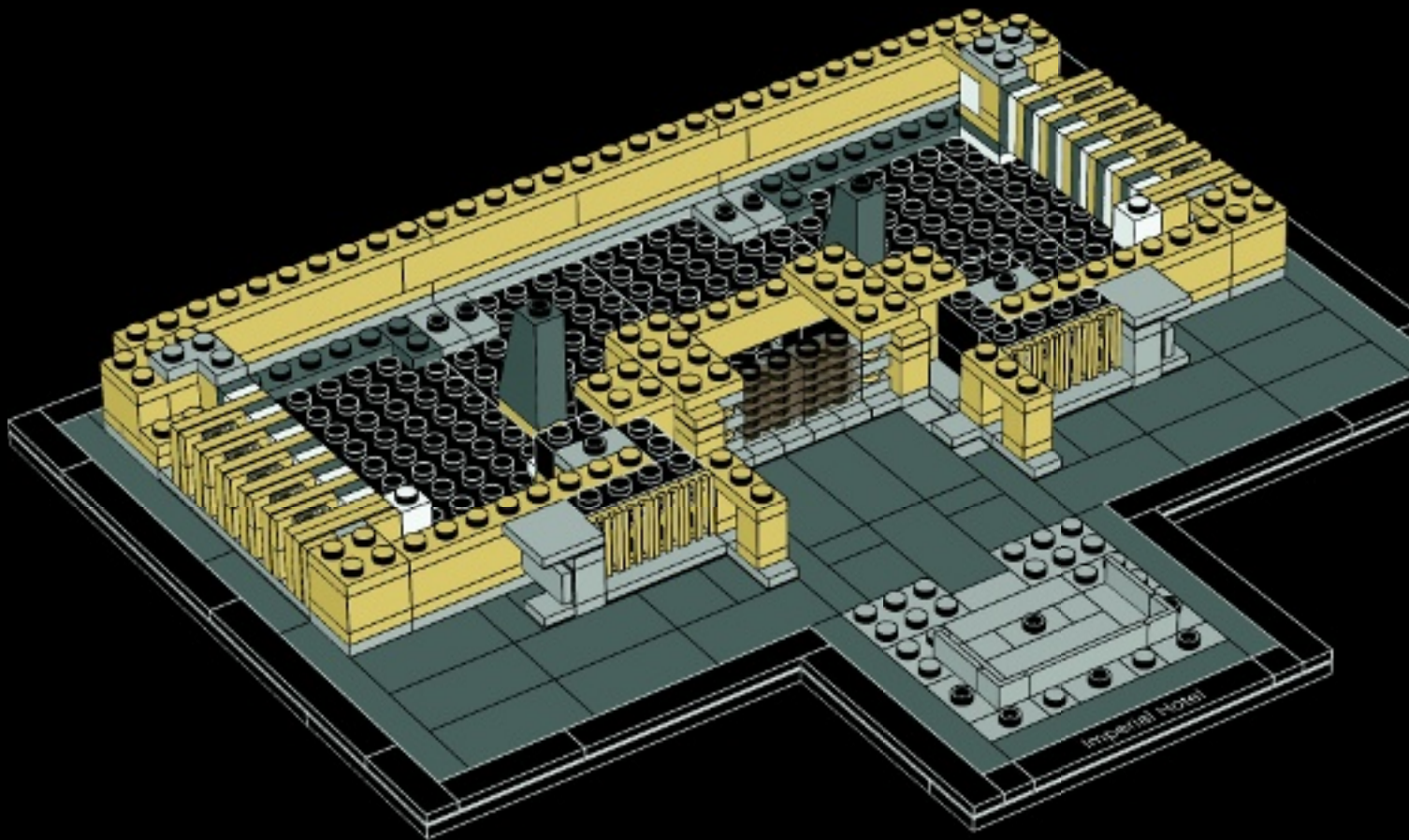



46

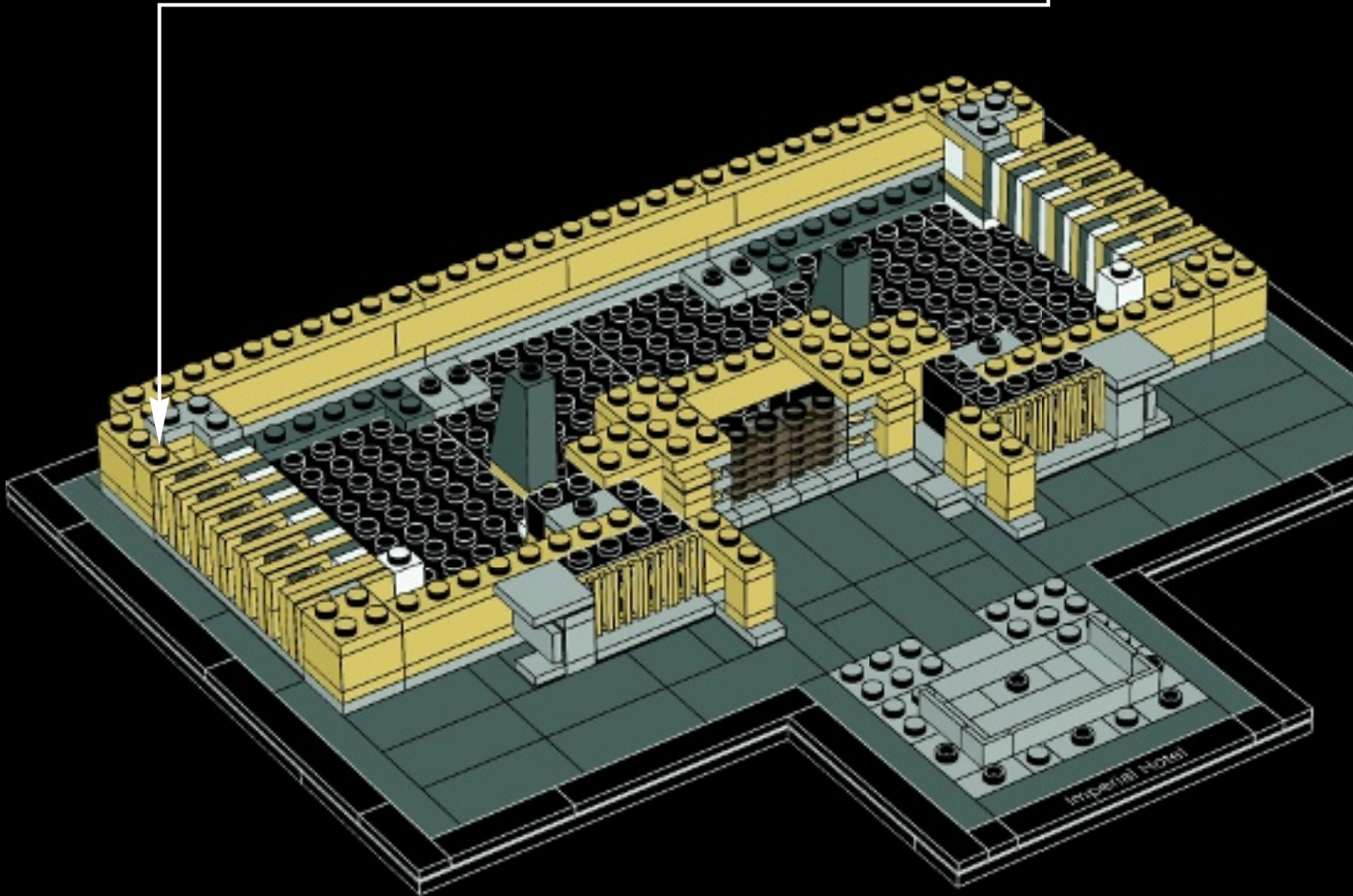



47

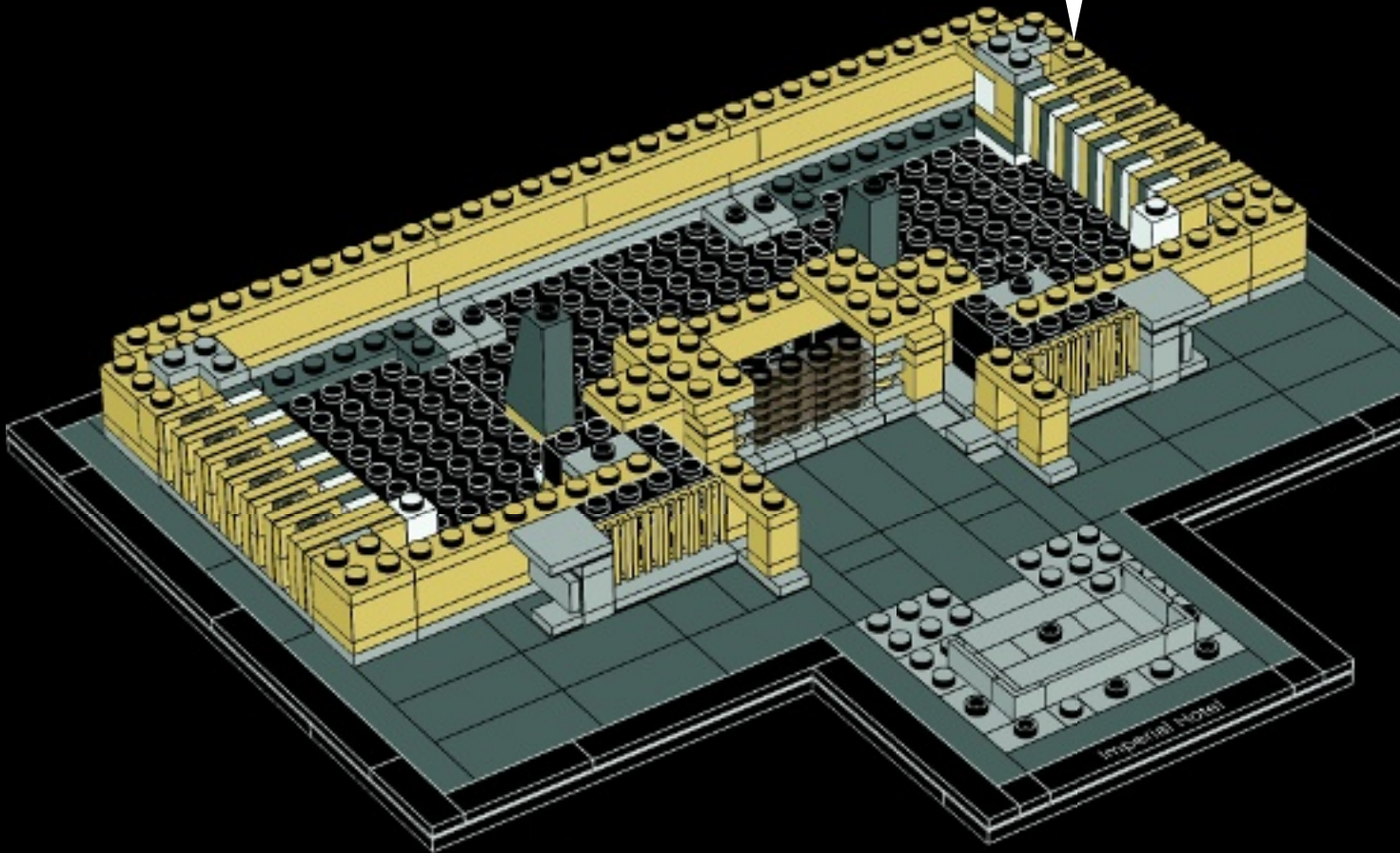

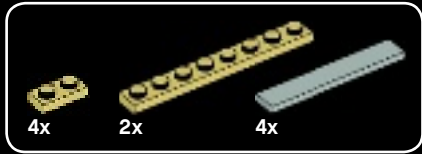

48

1



2

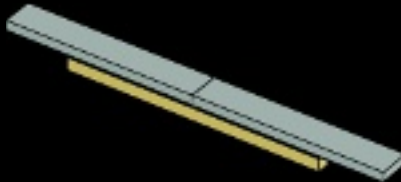

3

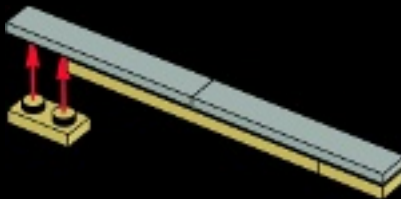

2x

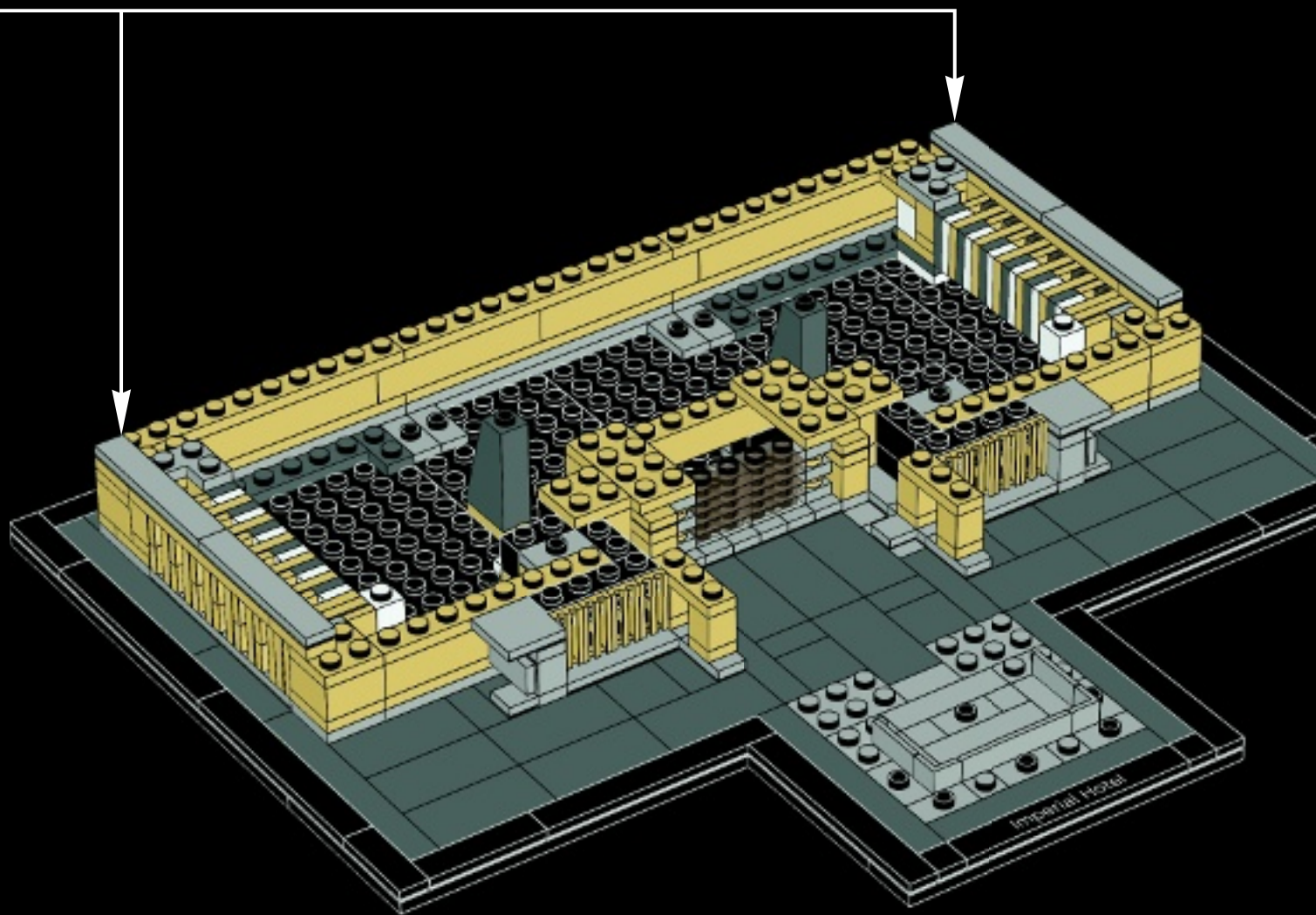

Imperial Hotel

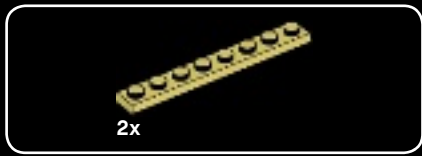

49

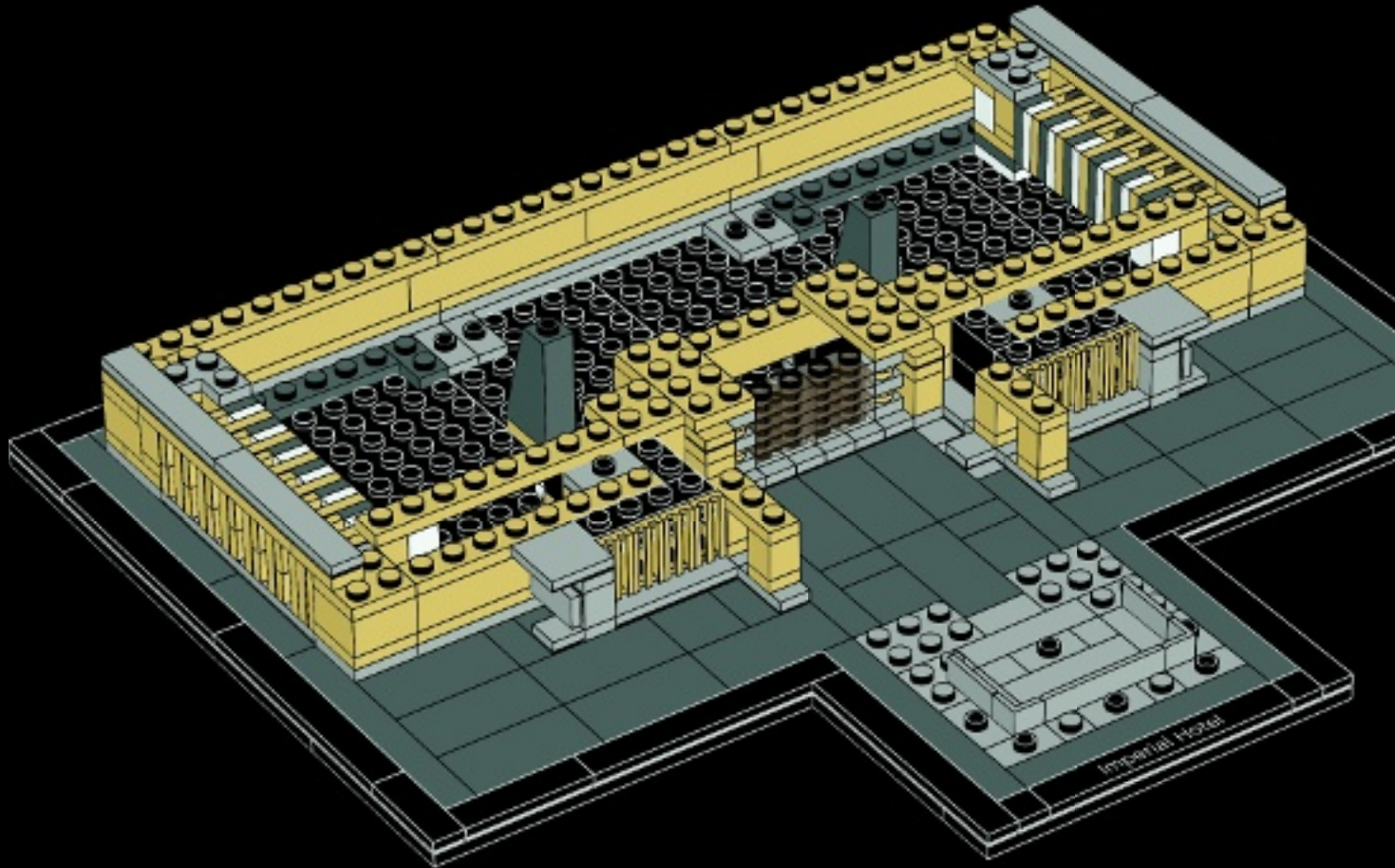



50

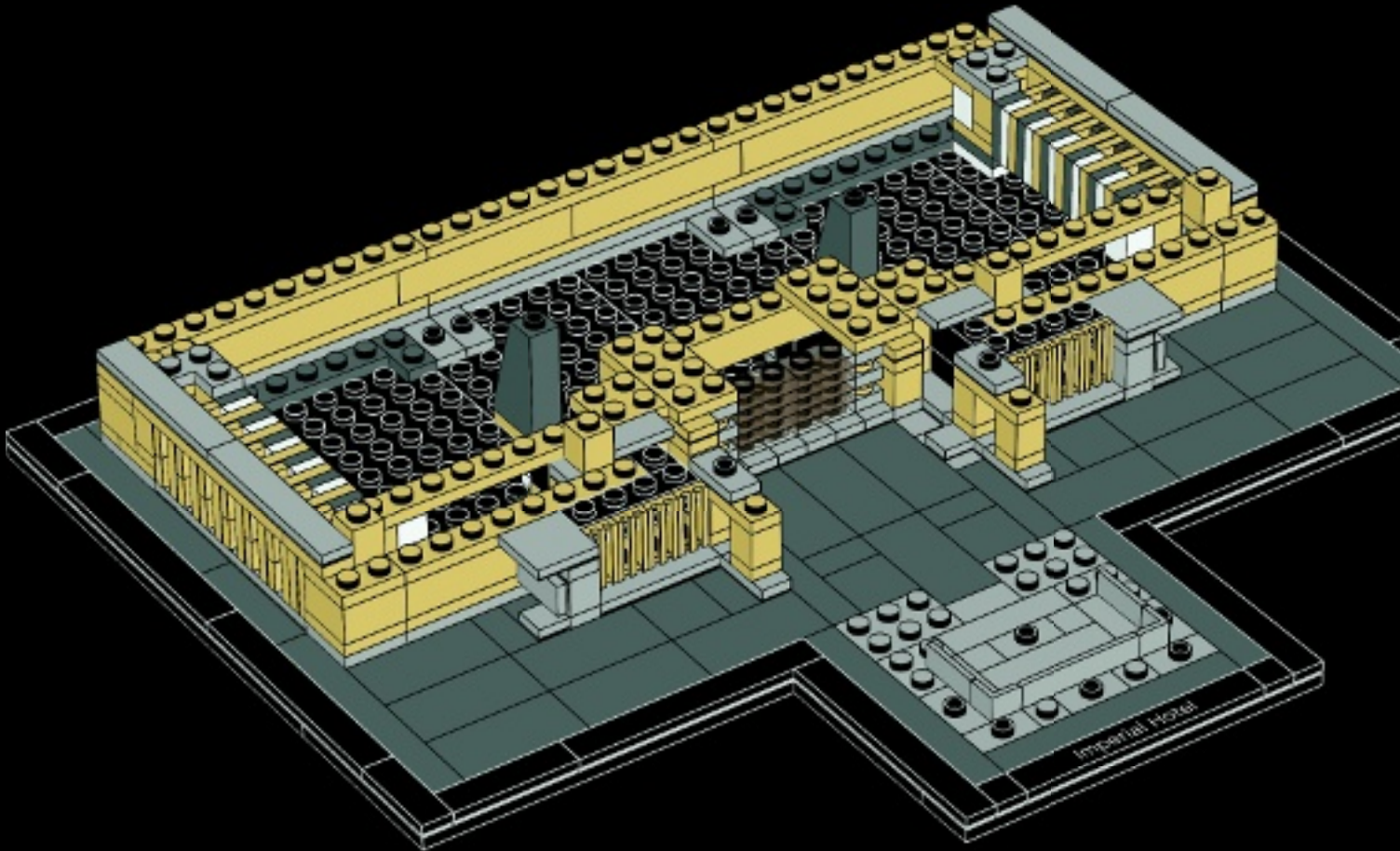

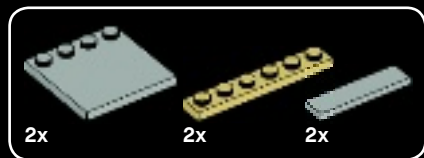

51

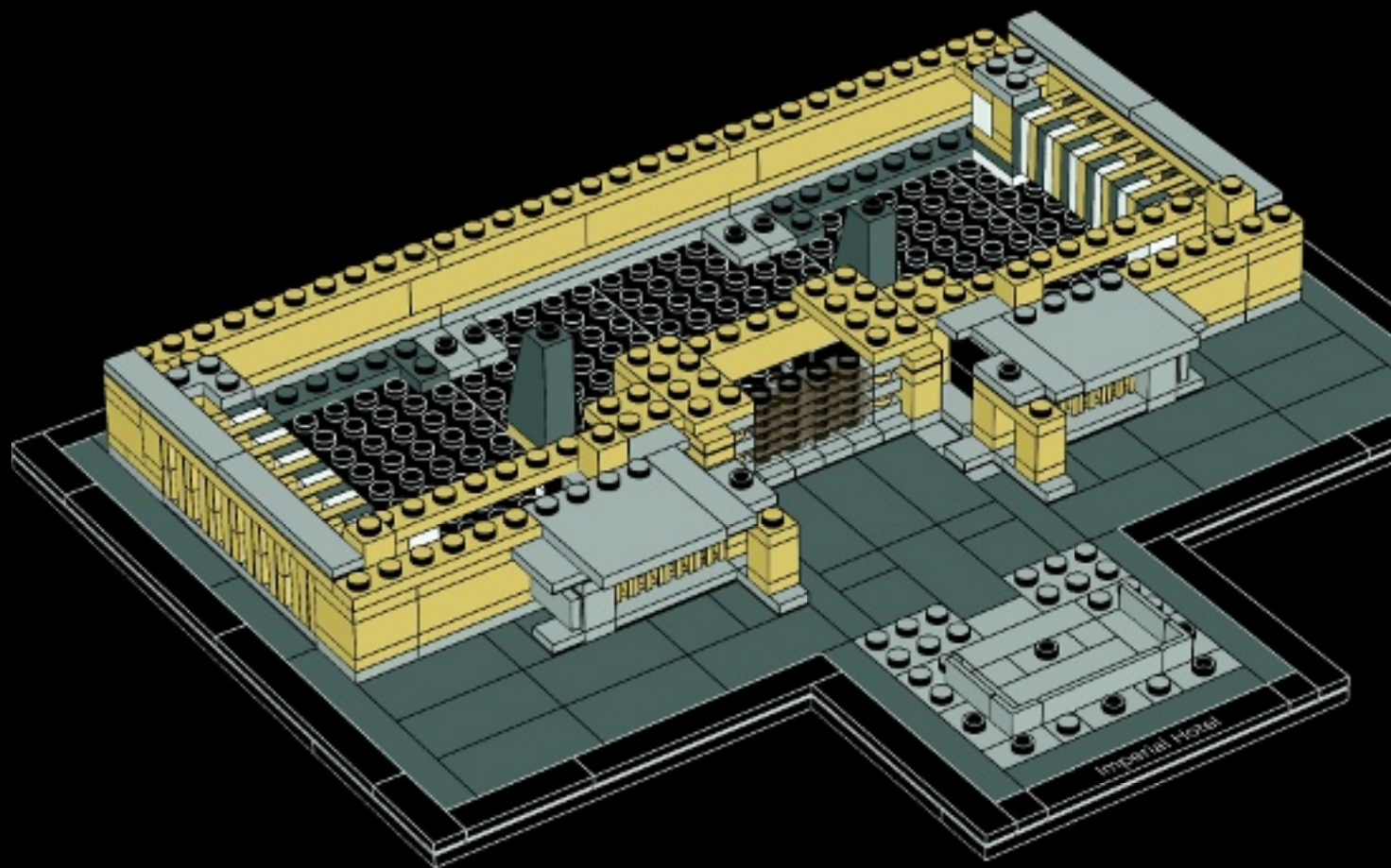



2x



2x



9x

52

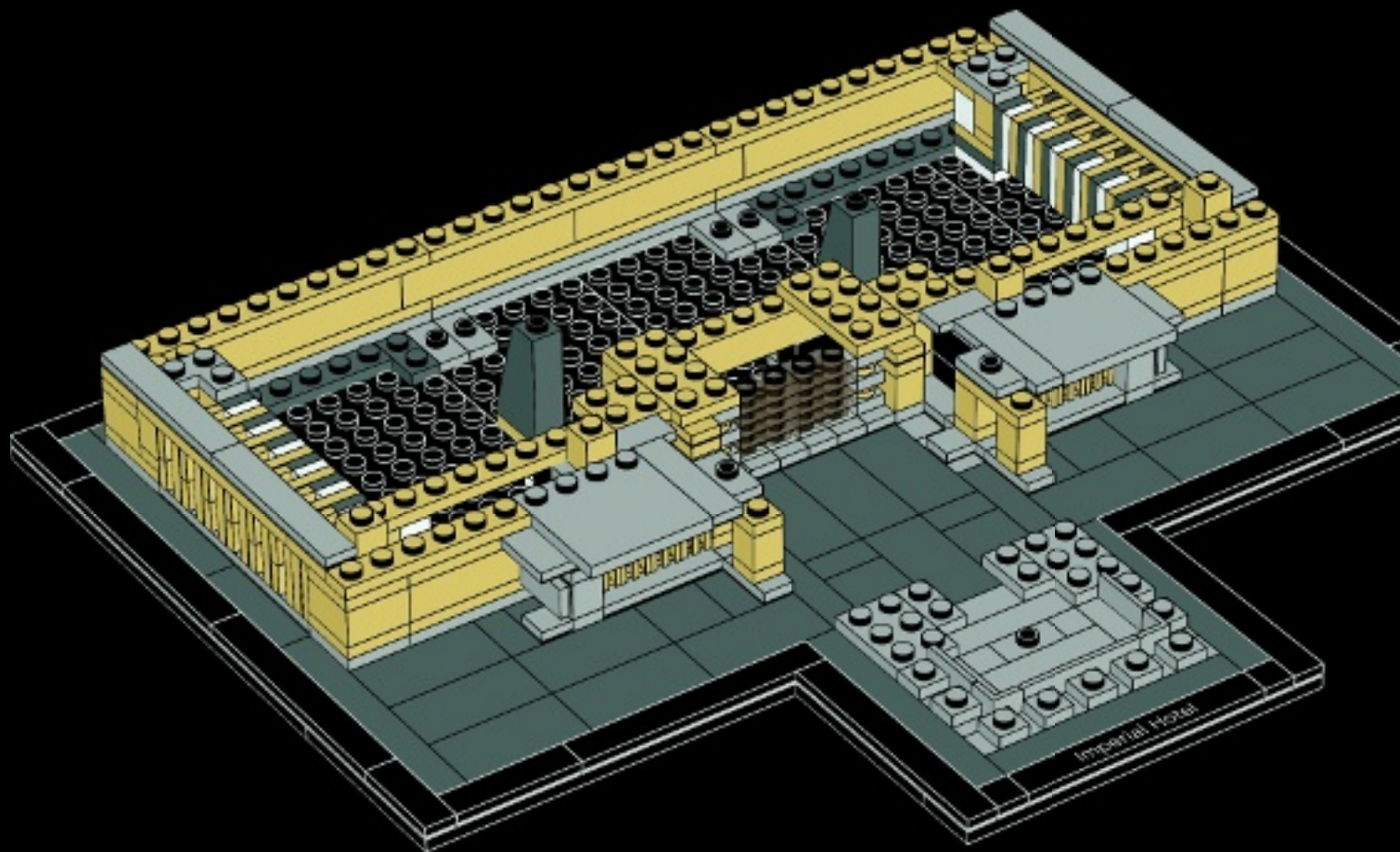



53

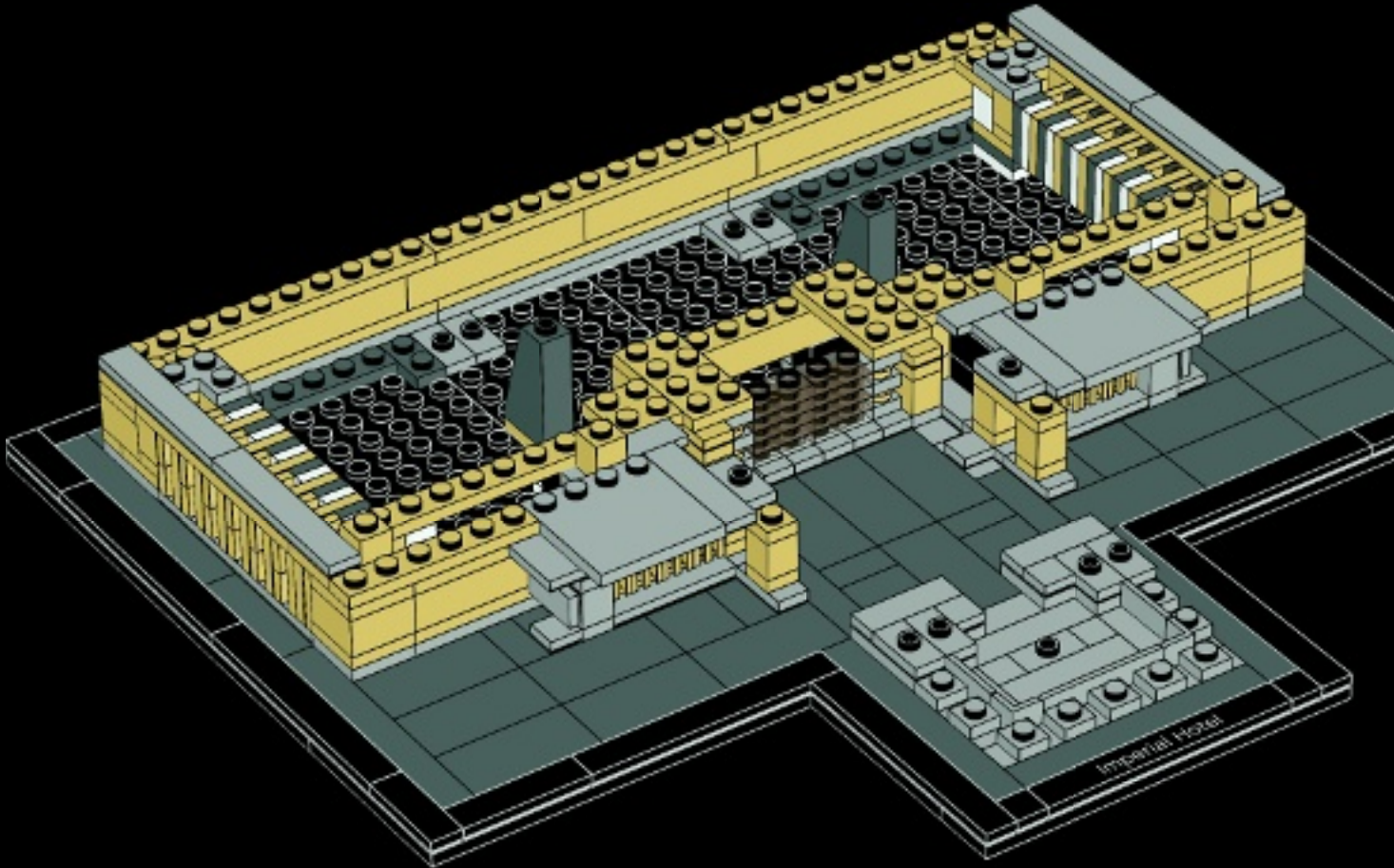



54

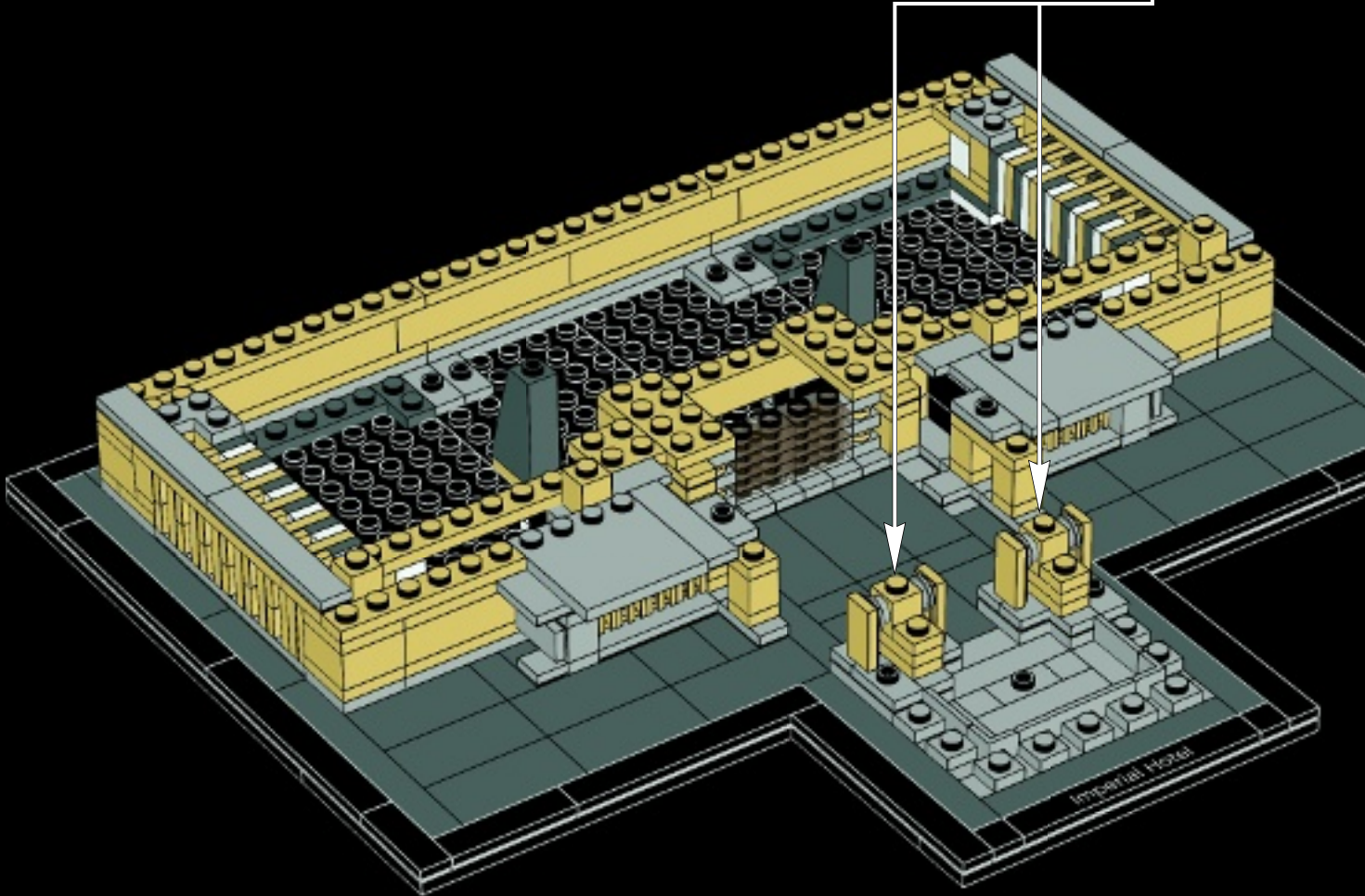



4x



2x



2x

55

1



2



2x

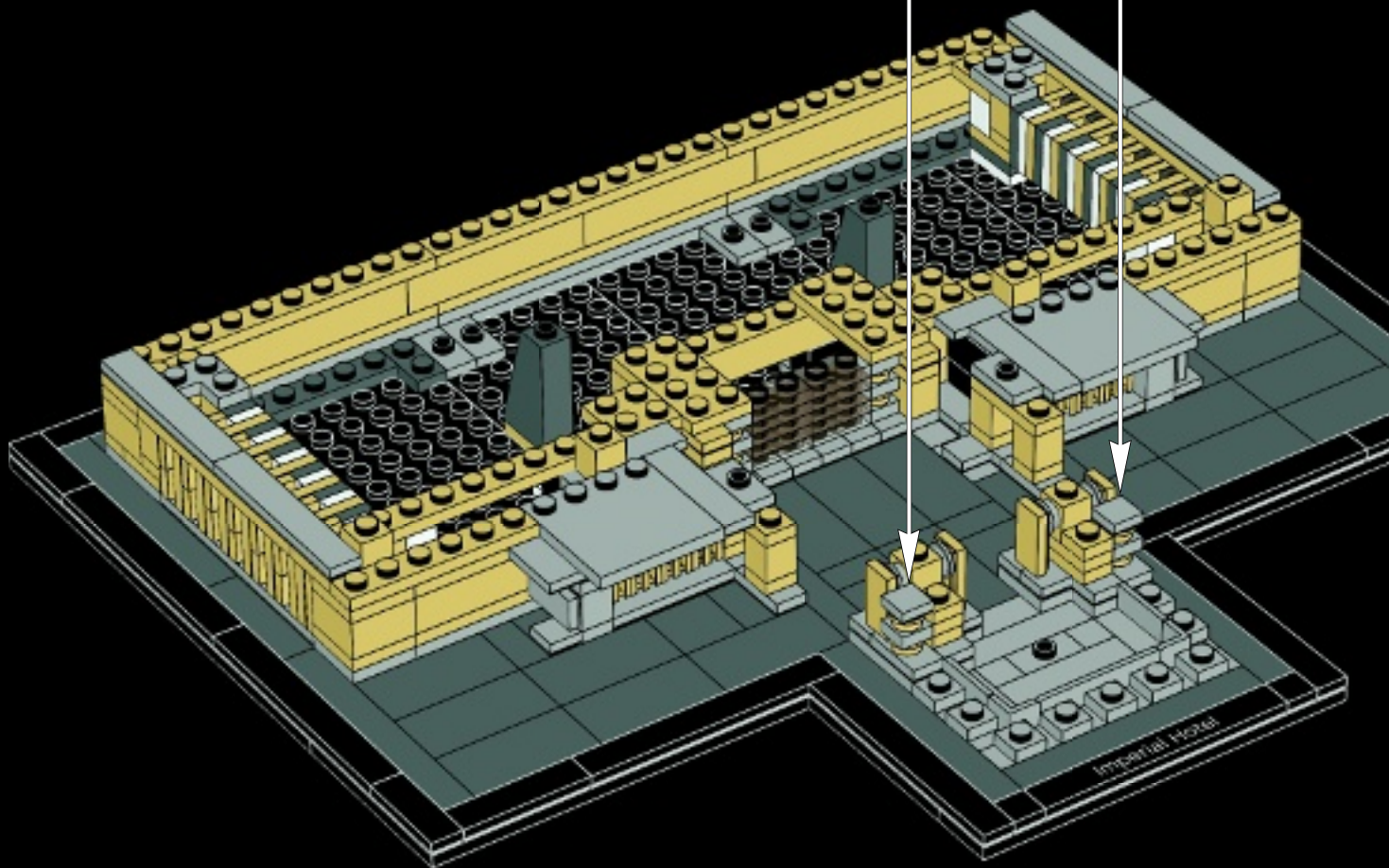

2x 1x 1x

56

1 2

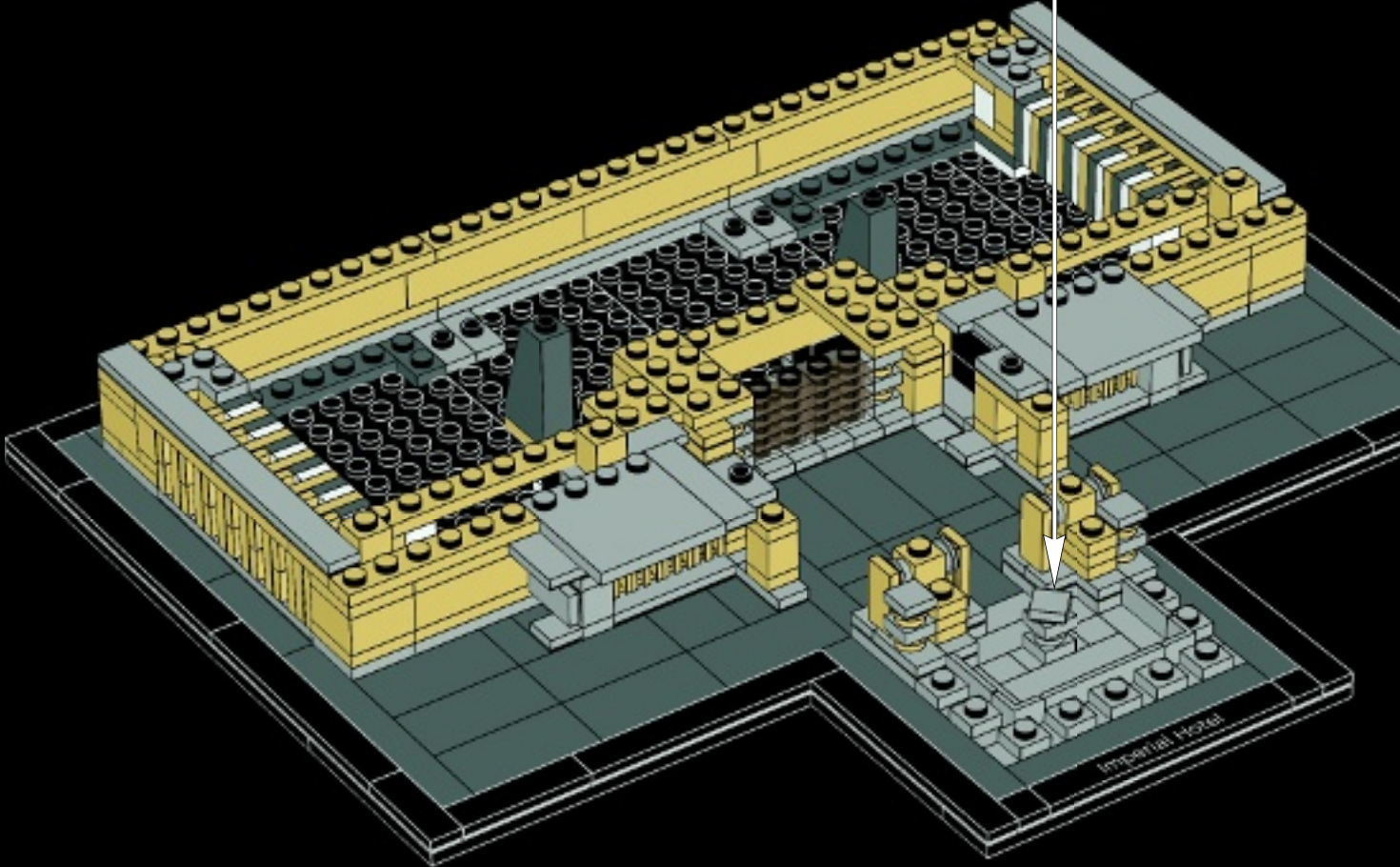
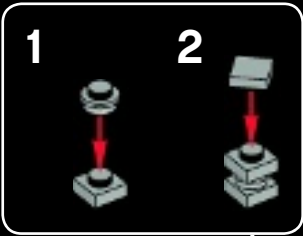

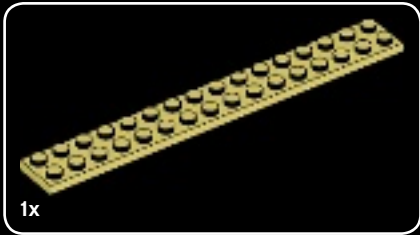
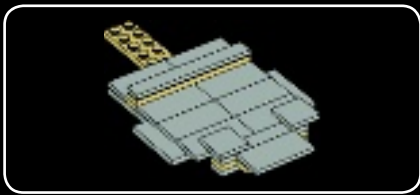

1x

1



2x

1x

2

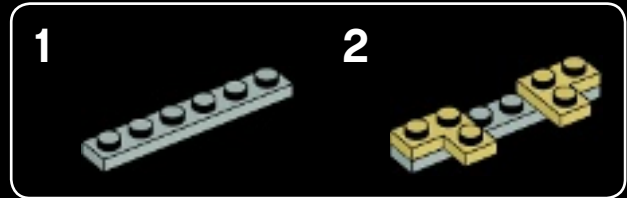

1

2

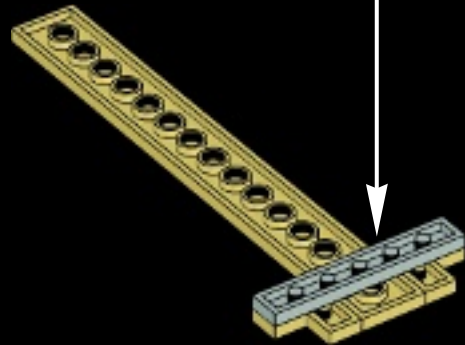

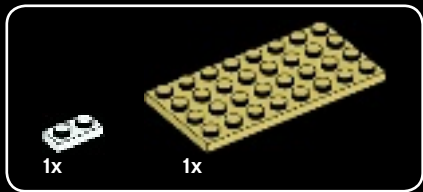

3

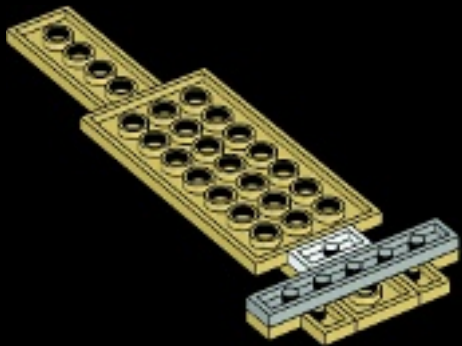

4

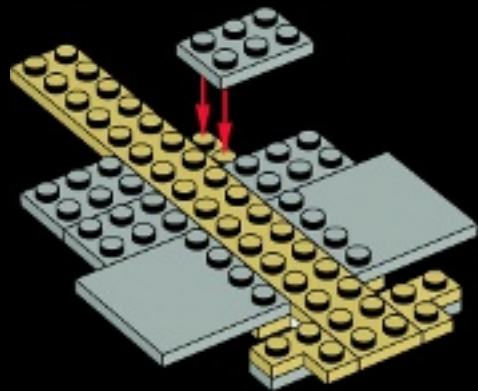
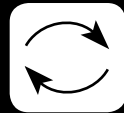



5

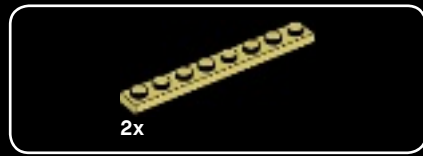
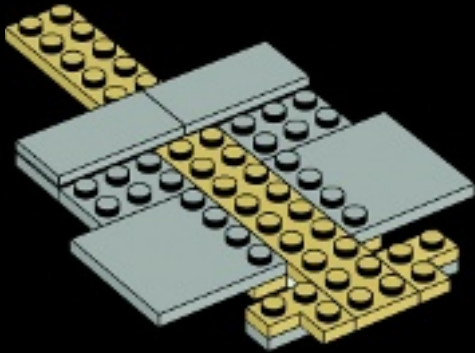

6

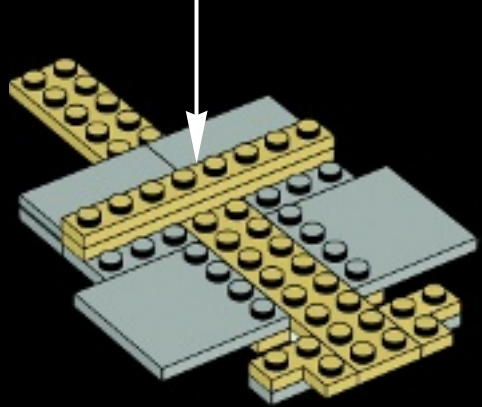
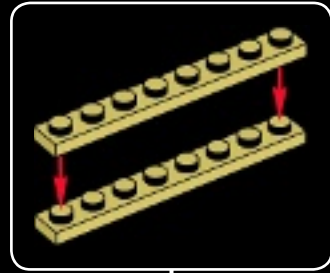



7

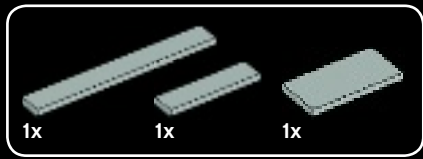
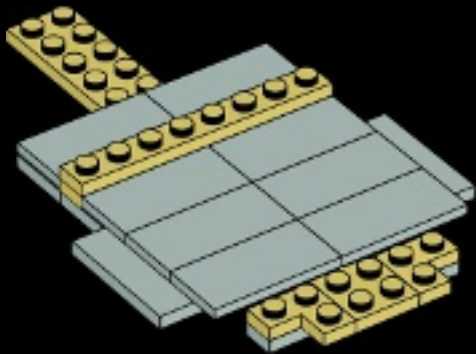

8

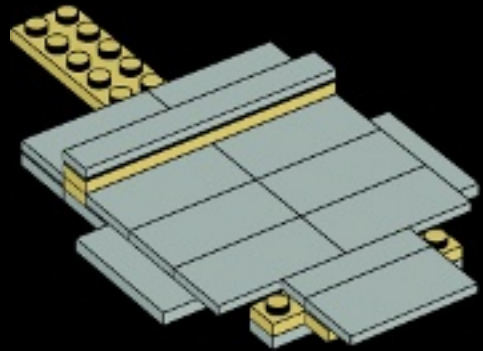



2x



2x

9

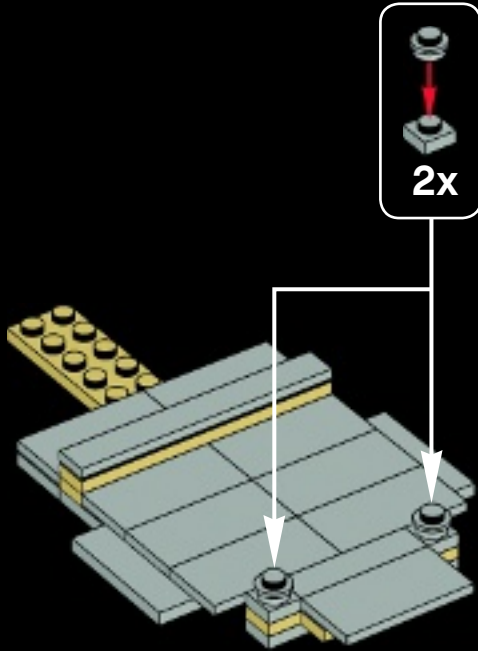

2x

10

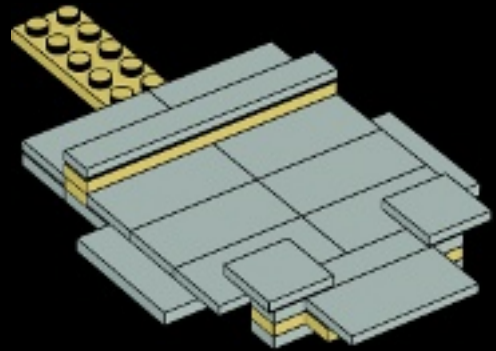

57

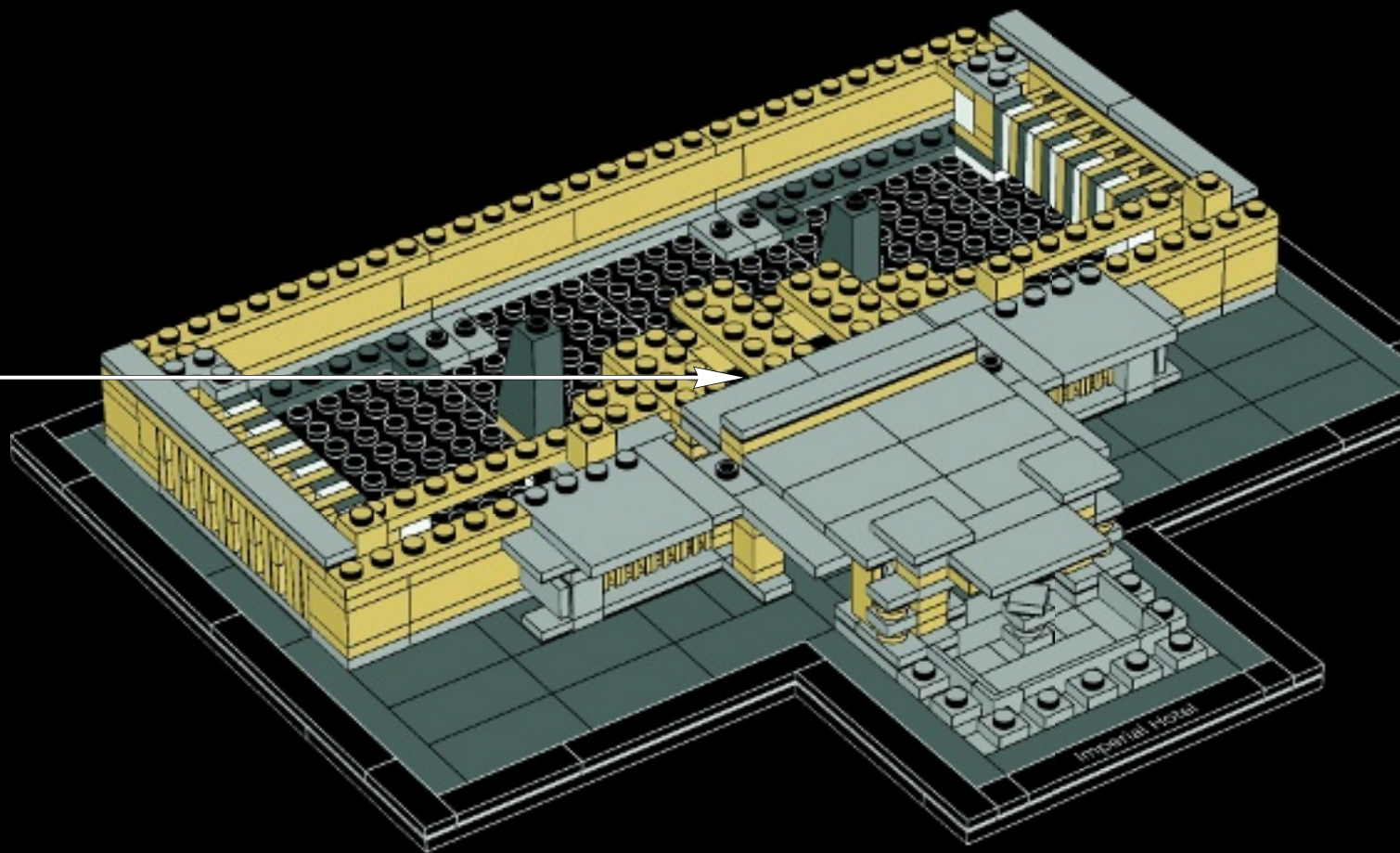

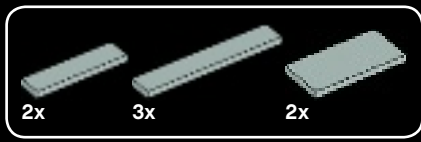

58

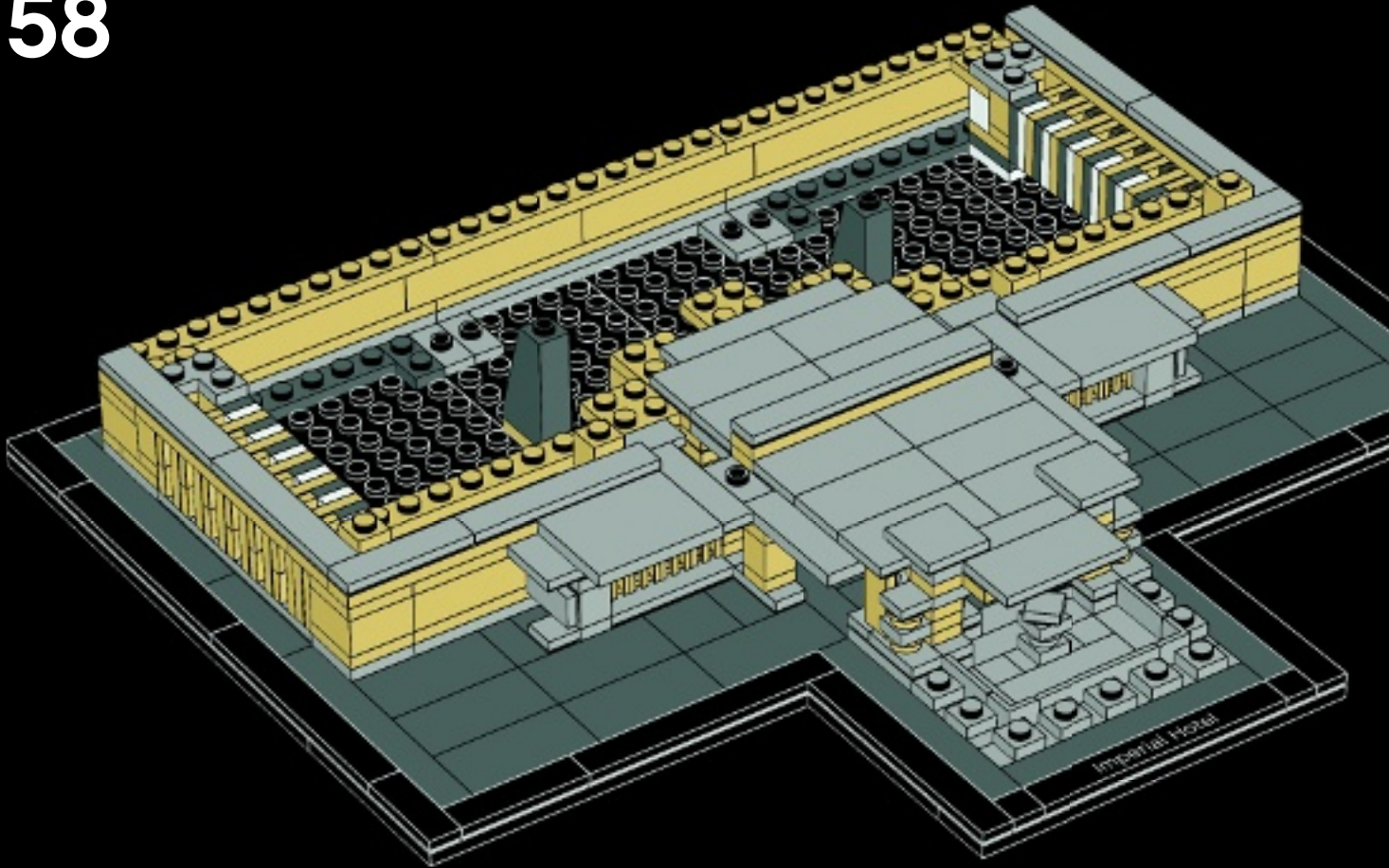

The copper rain gutters atop the perimeter of the building ensured rainwater would drain through elaborately patterned grills.

Le gouttières en cuivre qui parcouraient le haut du bâtiment conduisaient l'eau de pluie jusqu'au sol par le biais de grilles aux motifs élaborés.



Courtesy of the Frank Lloyd Wright Foundation
Avec l'autorisation de la Frank Lloyd Wright Foundation

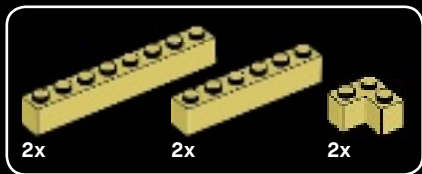

59

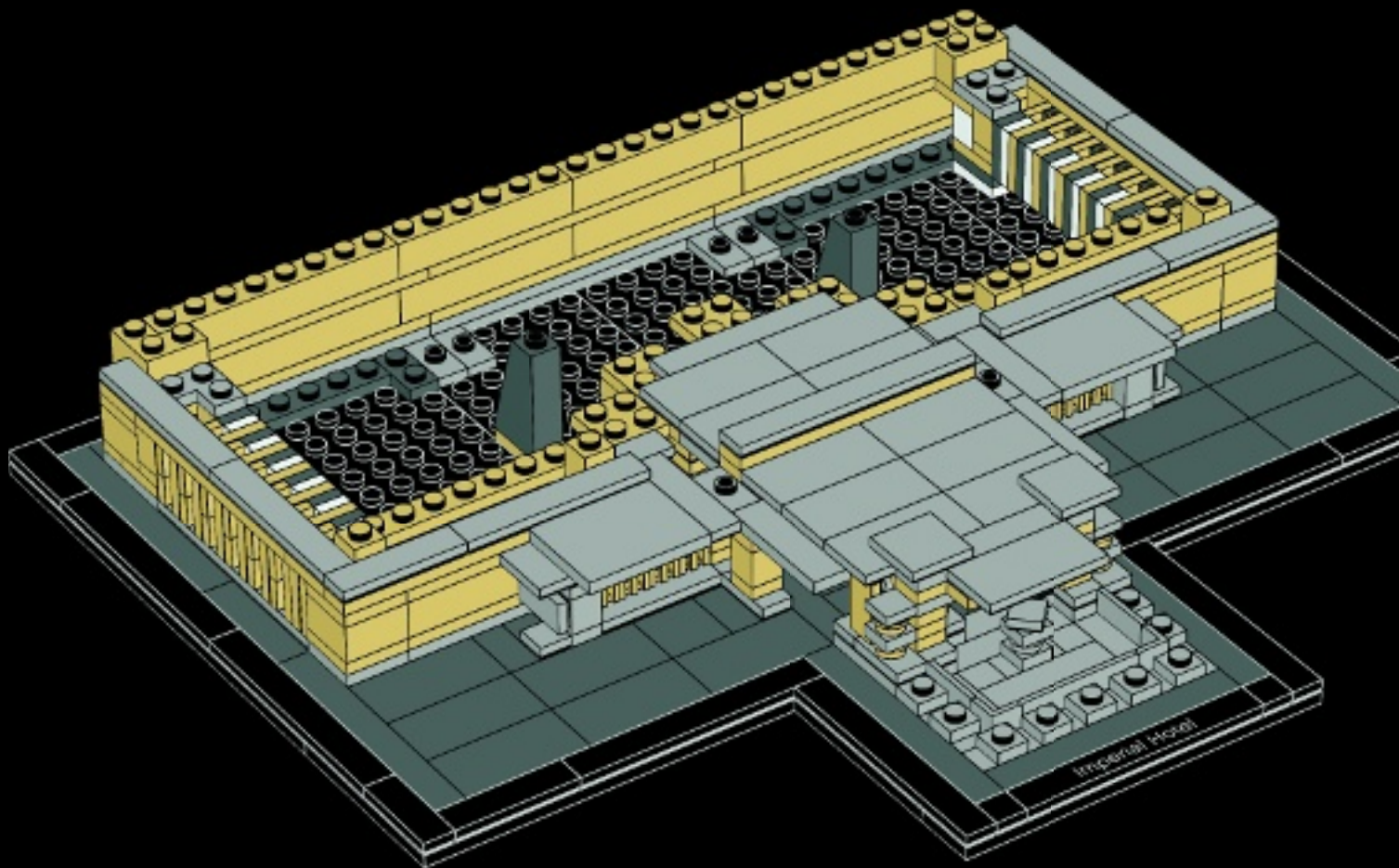



4x



2x

60

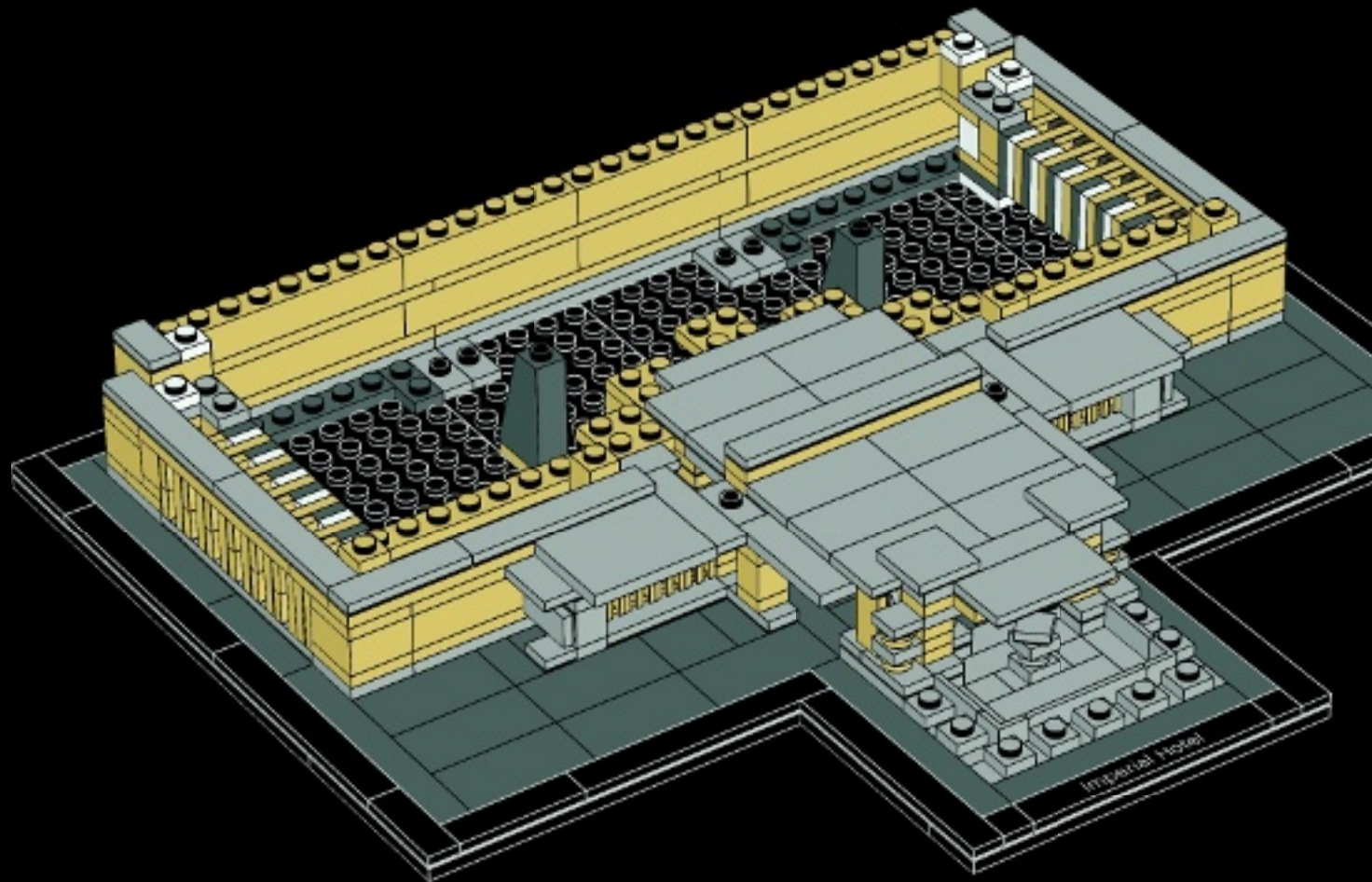

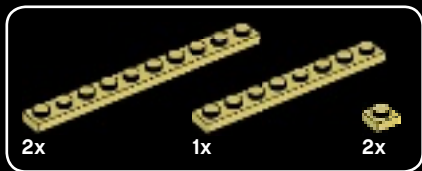

61

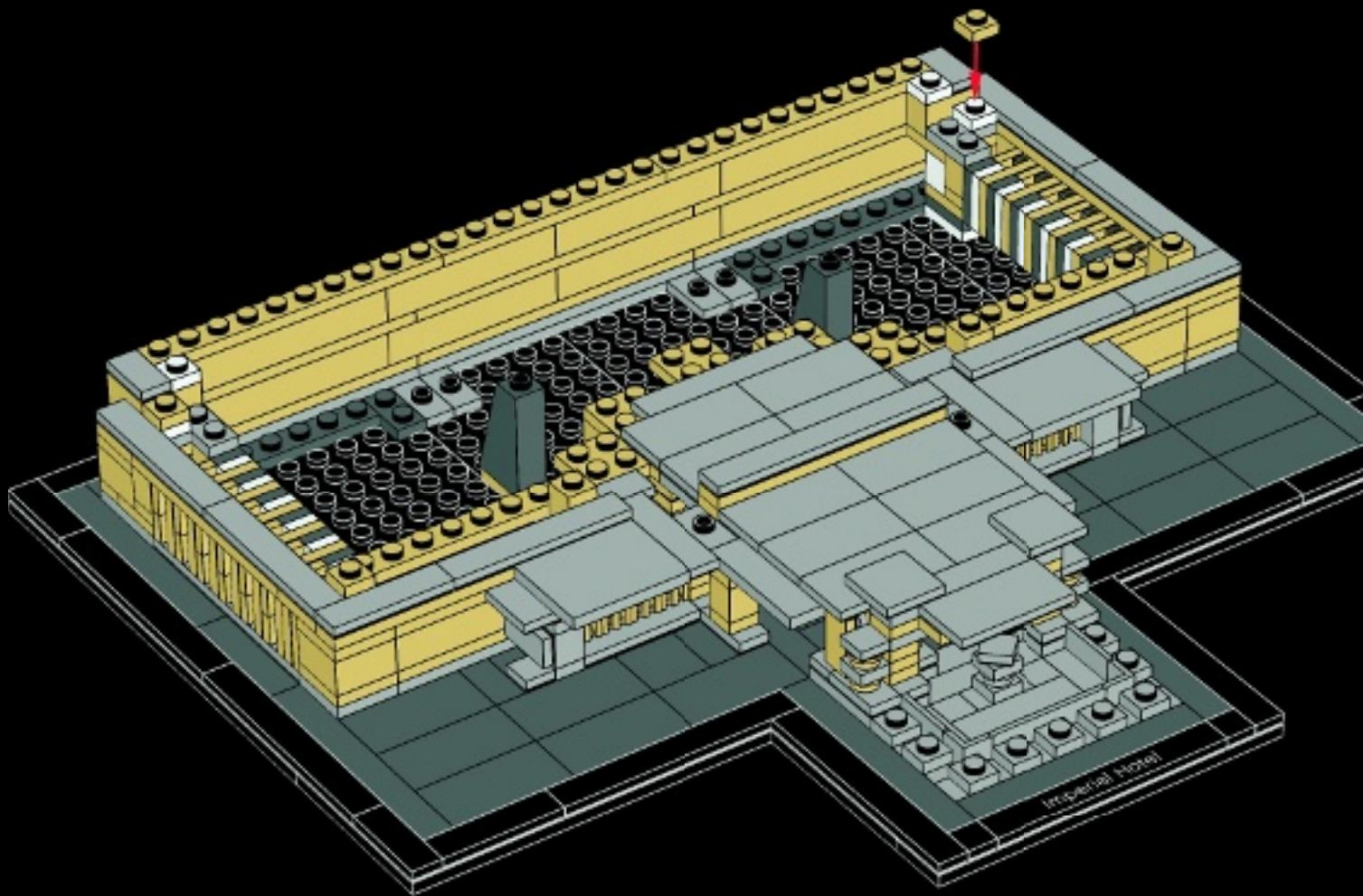

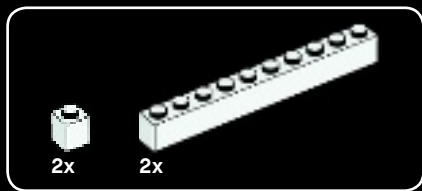

62

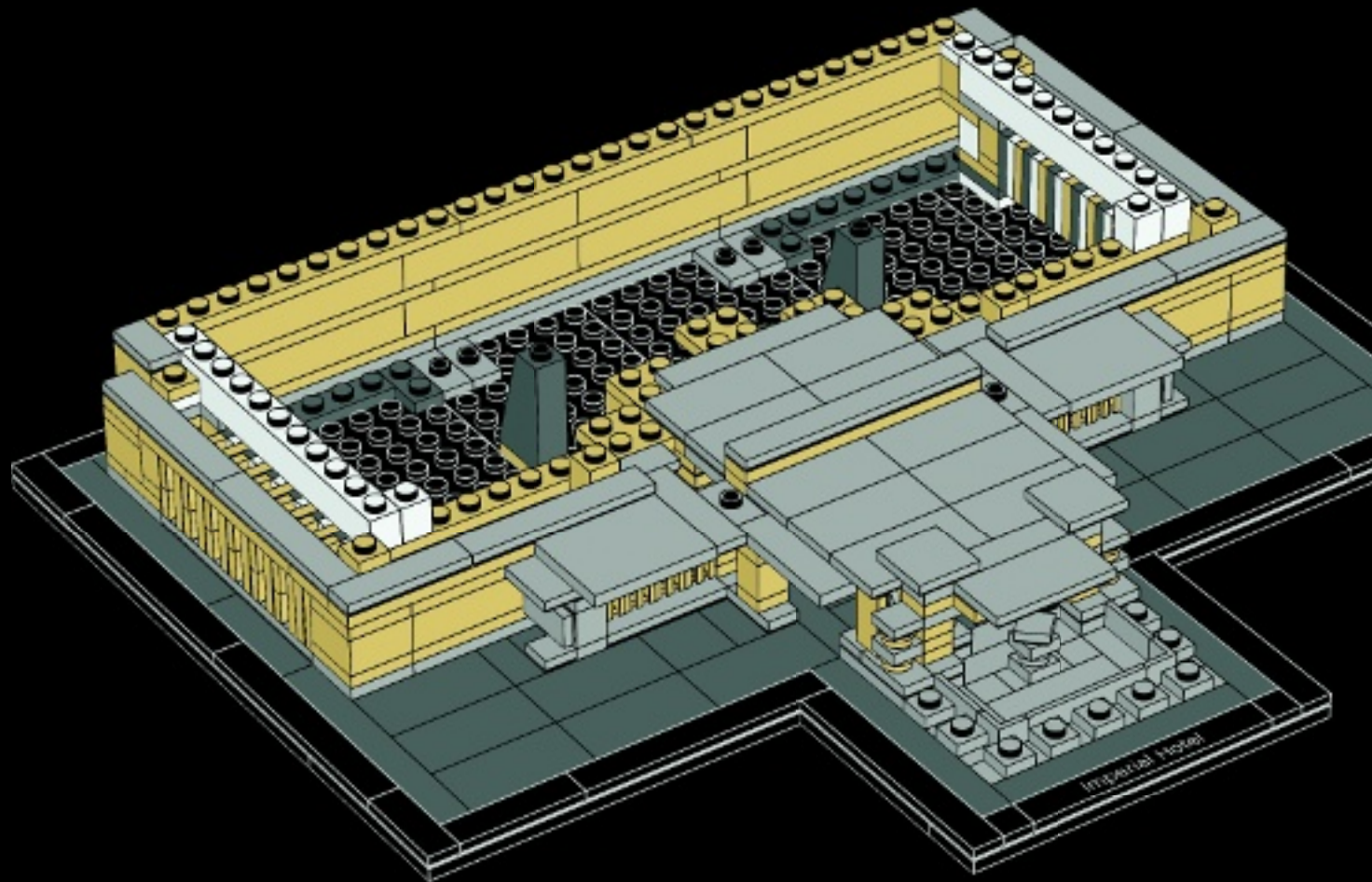

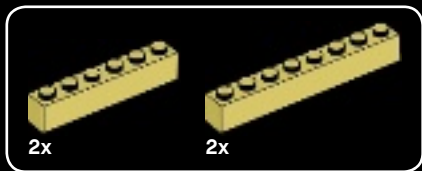

63

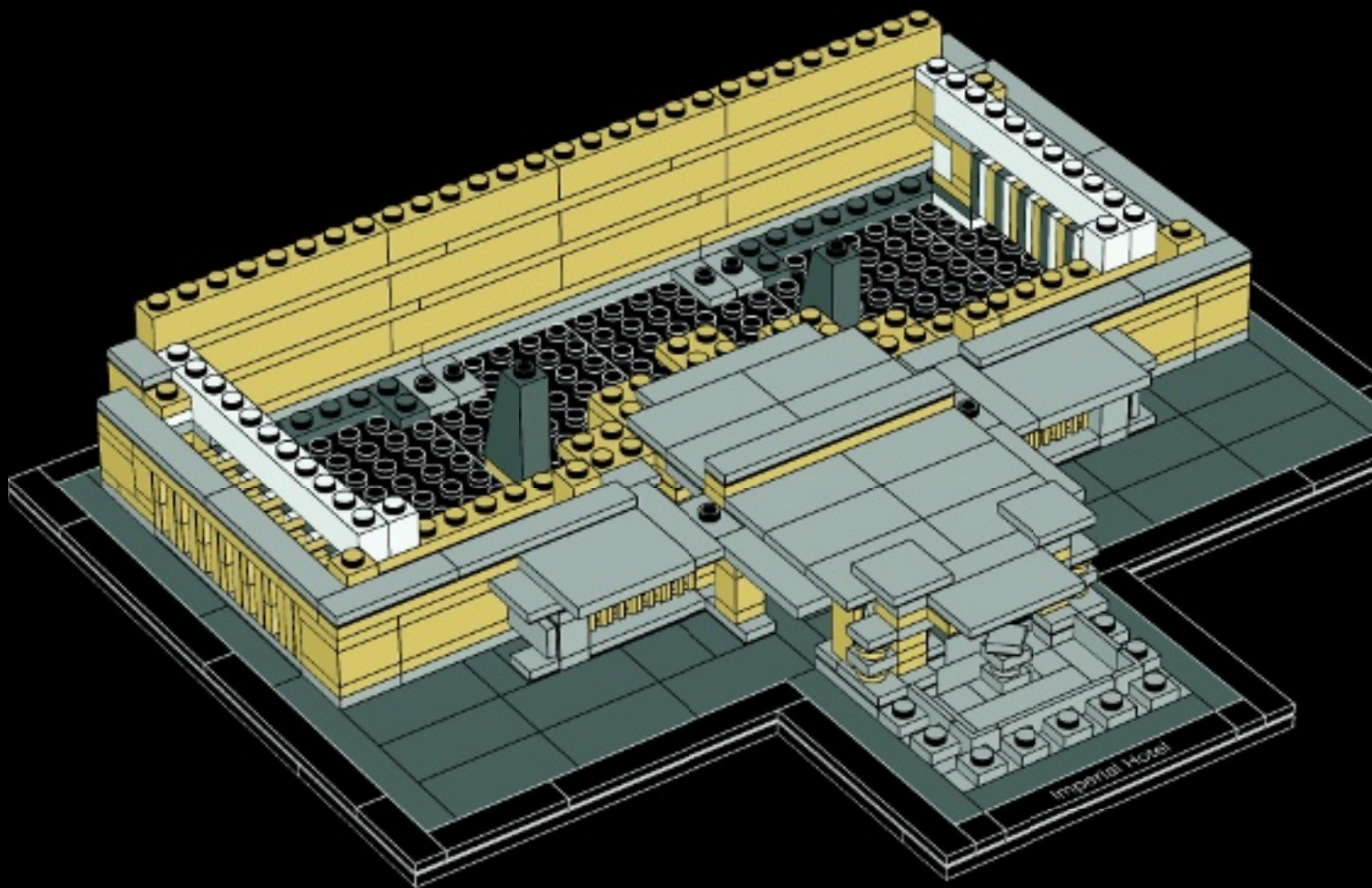

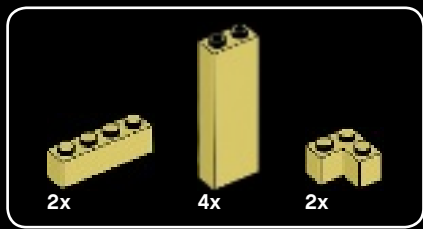

64

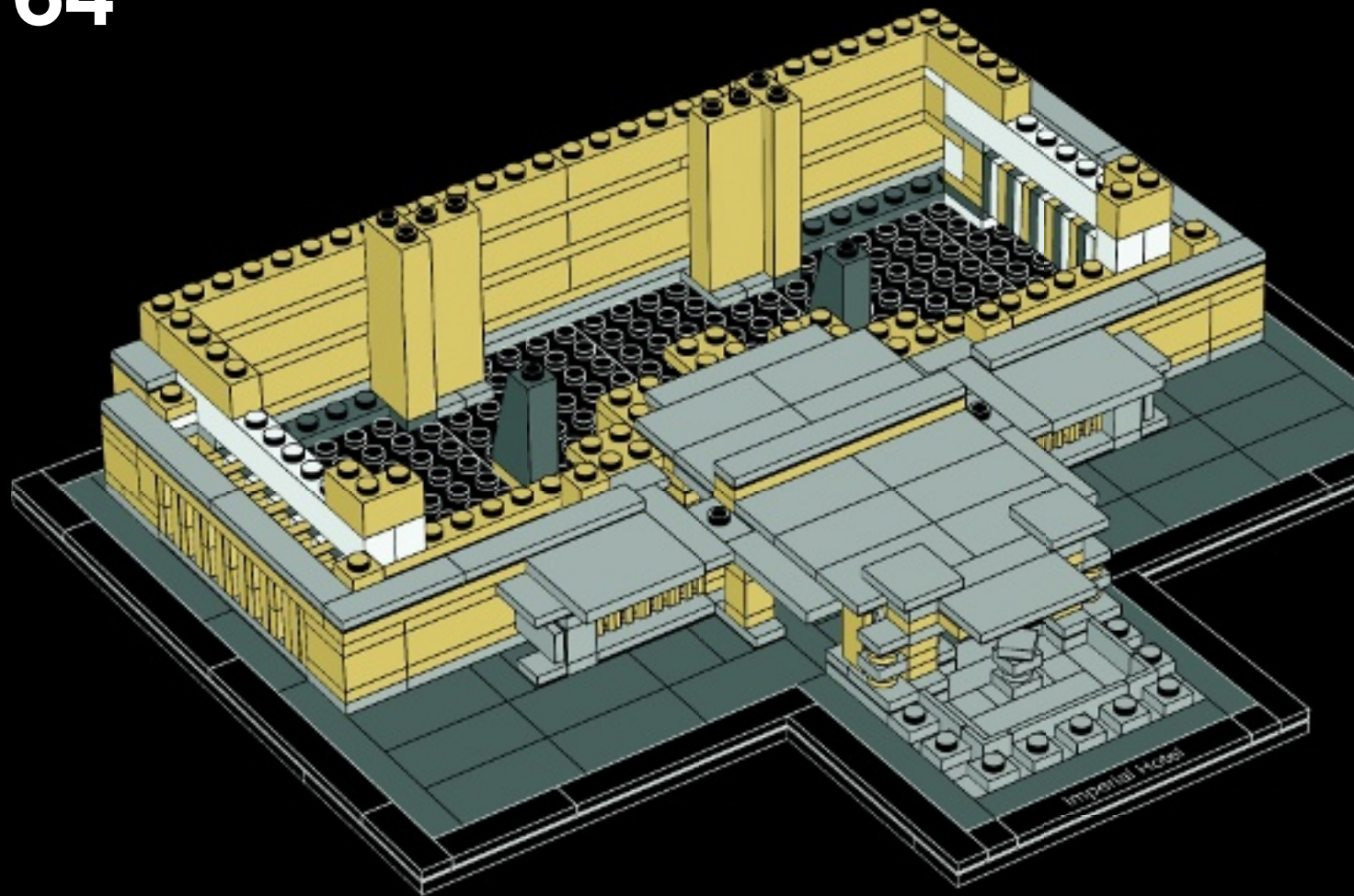



65

1



2



3

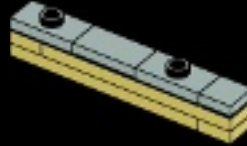

1



2



4

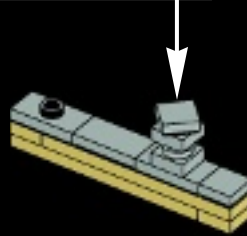

2x

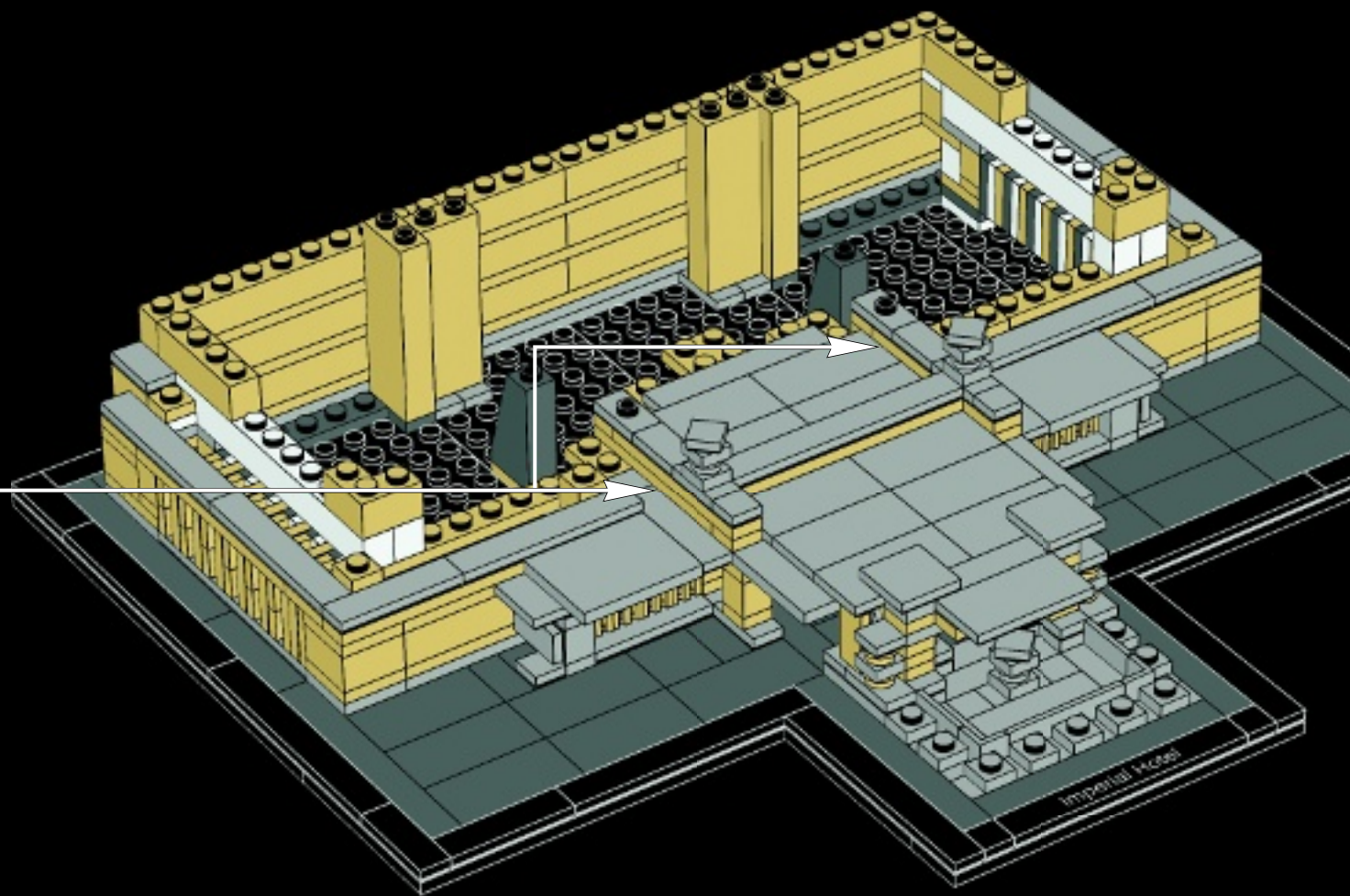



66

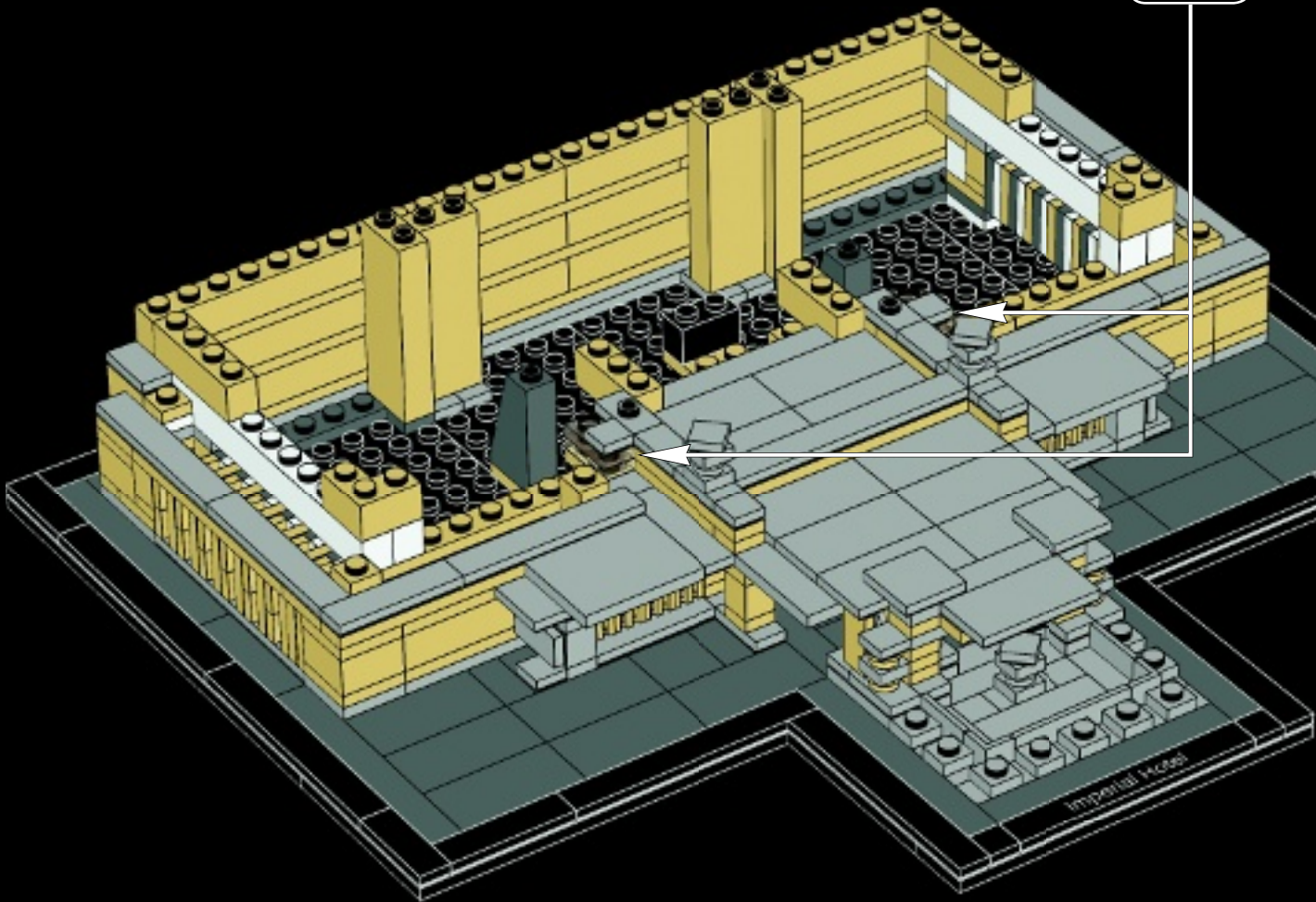



67

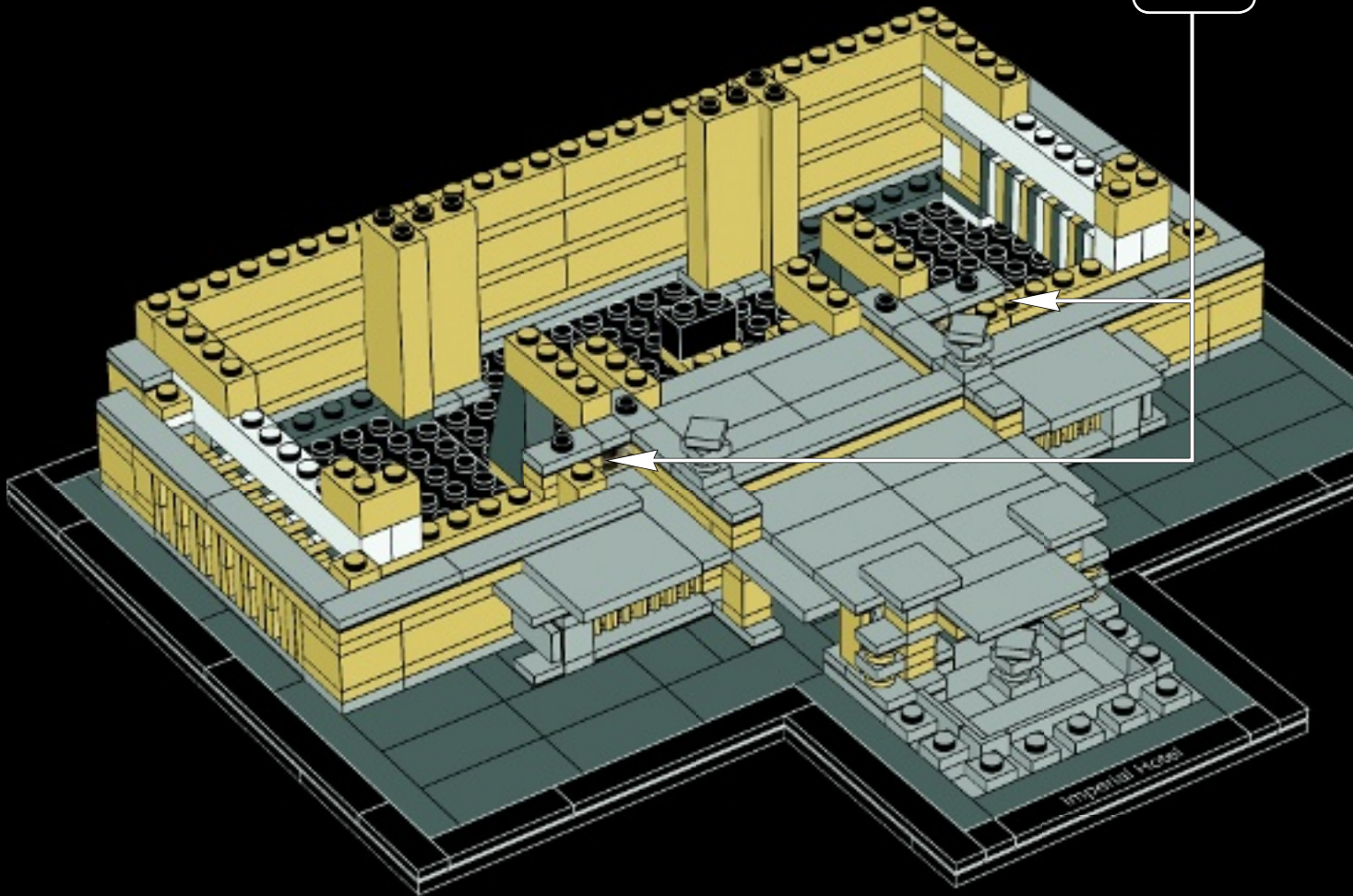
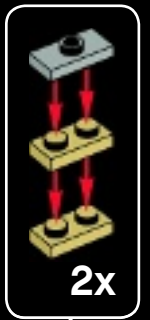



2x



4x



4x

68

1



2



2x

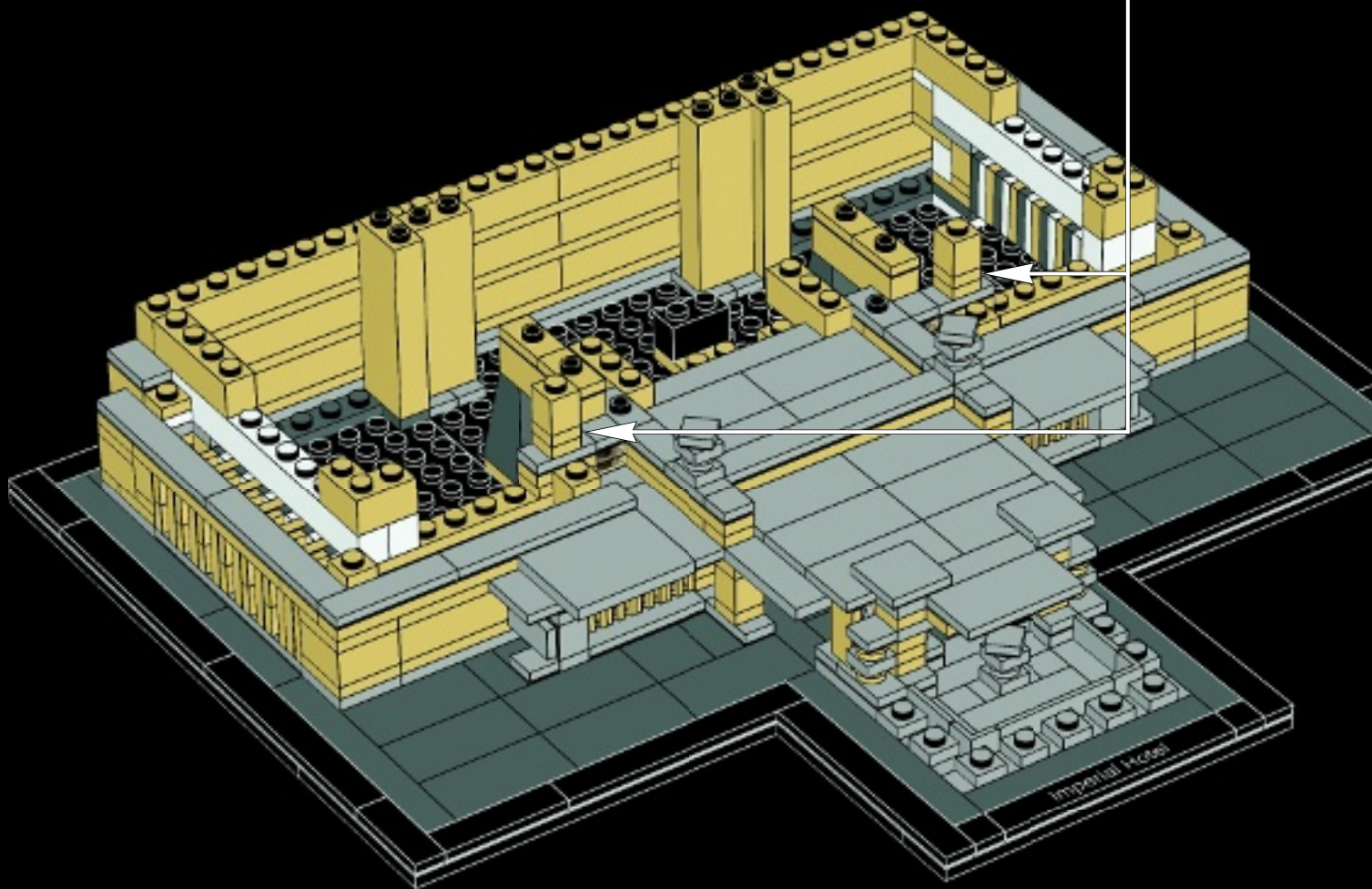



1x



2x

69

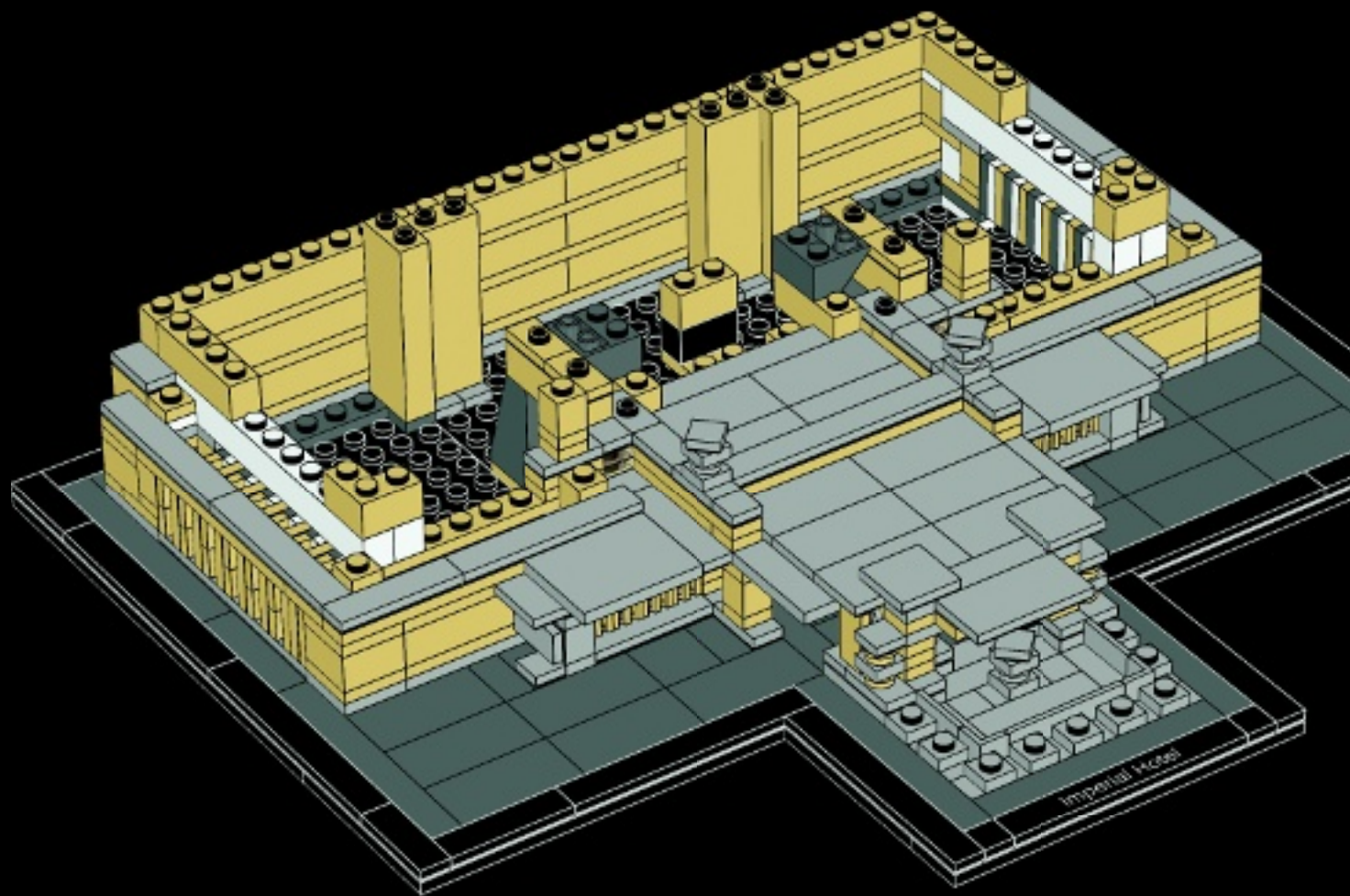

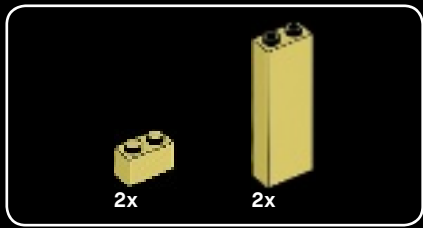

70

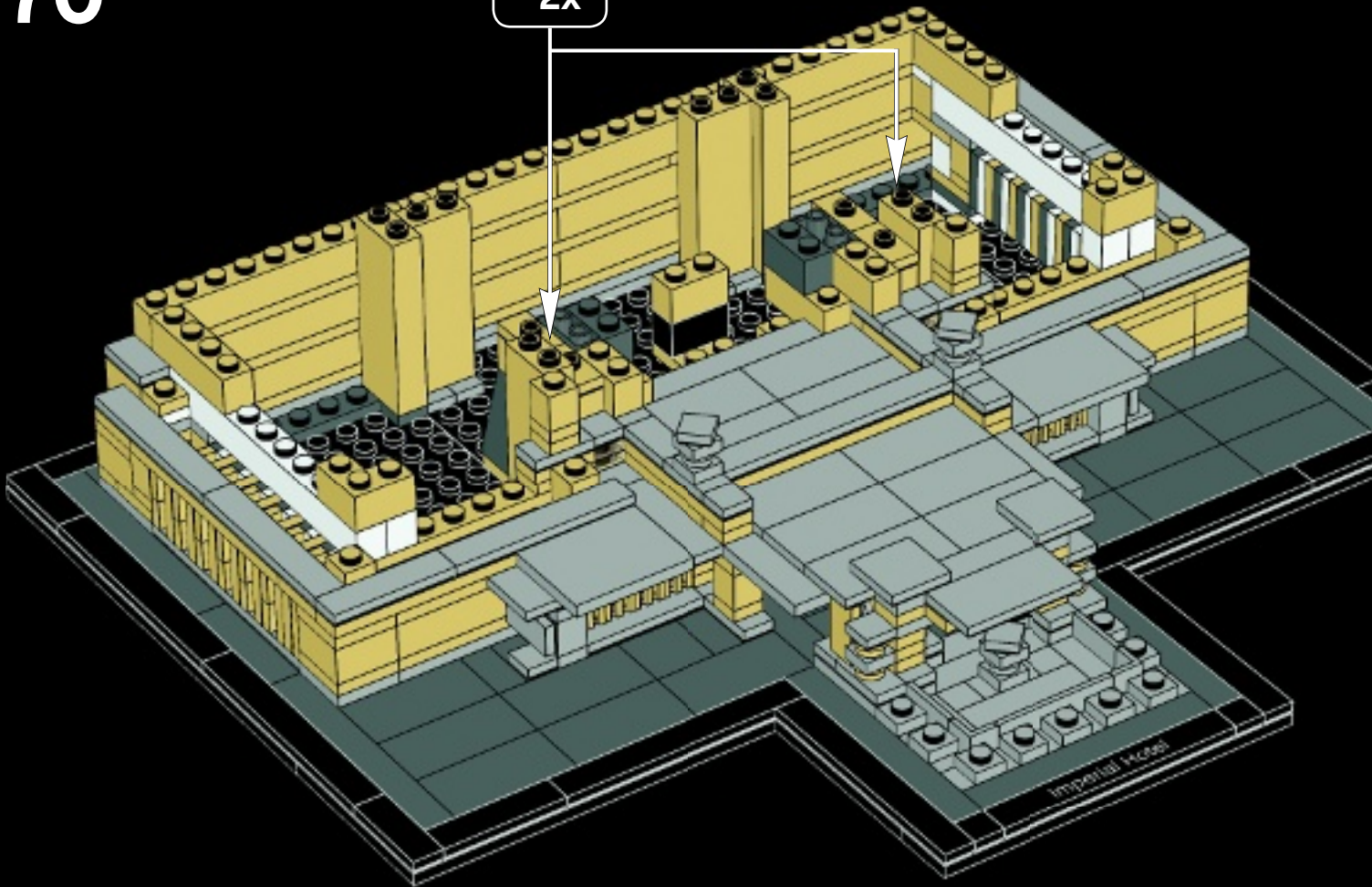



71

1



2



3



4



5



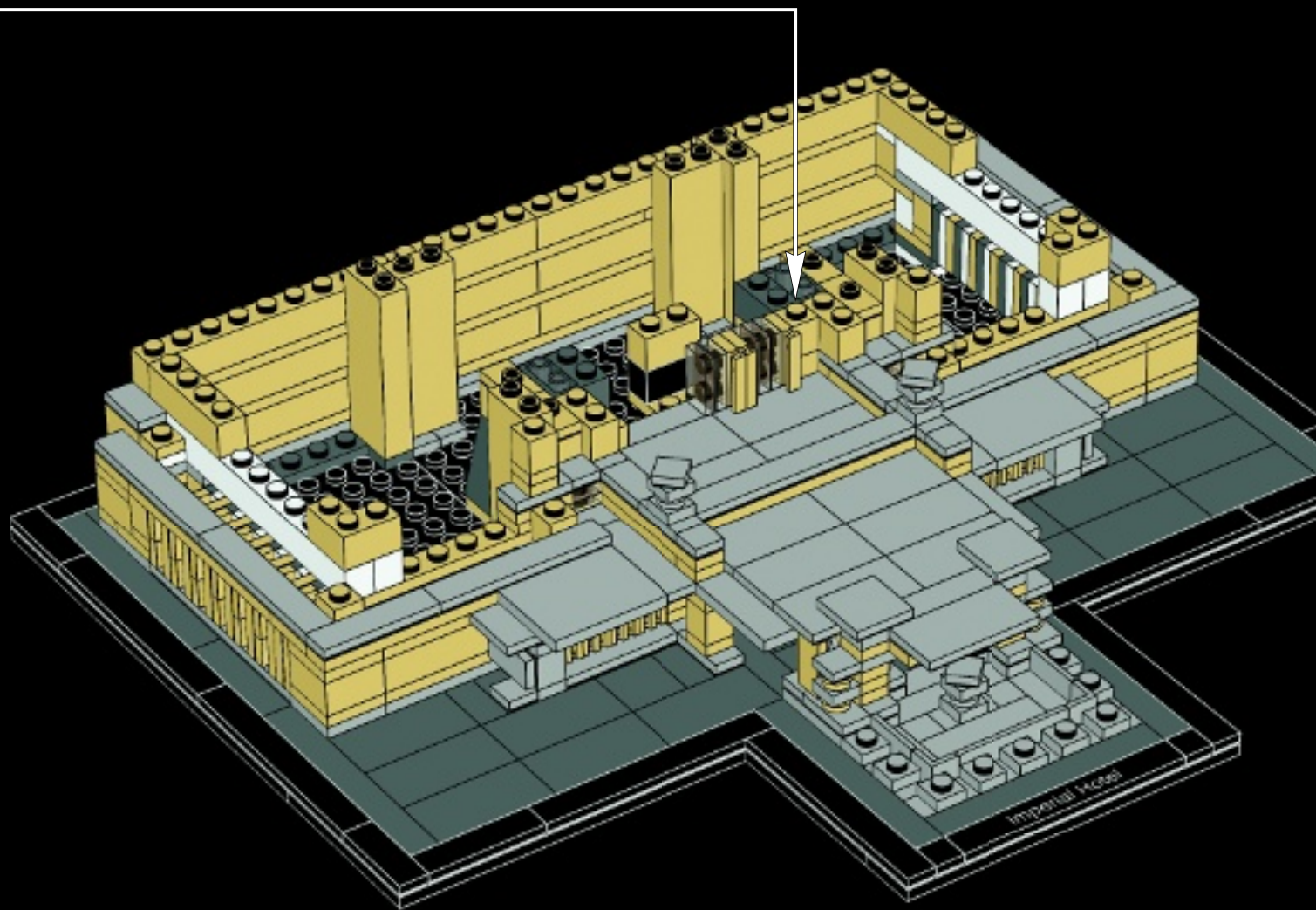



72

1



2



3



4



5

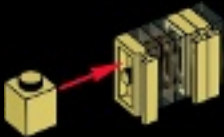

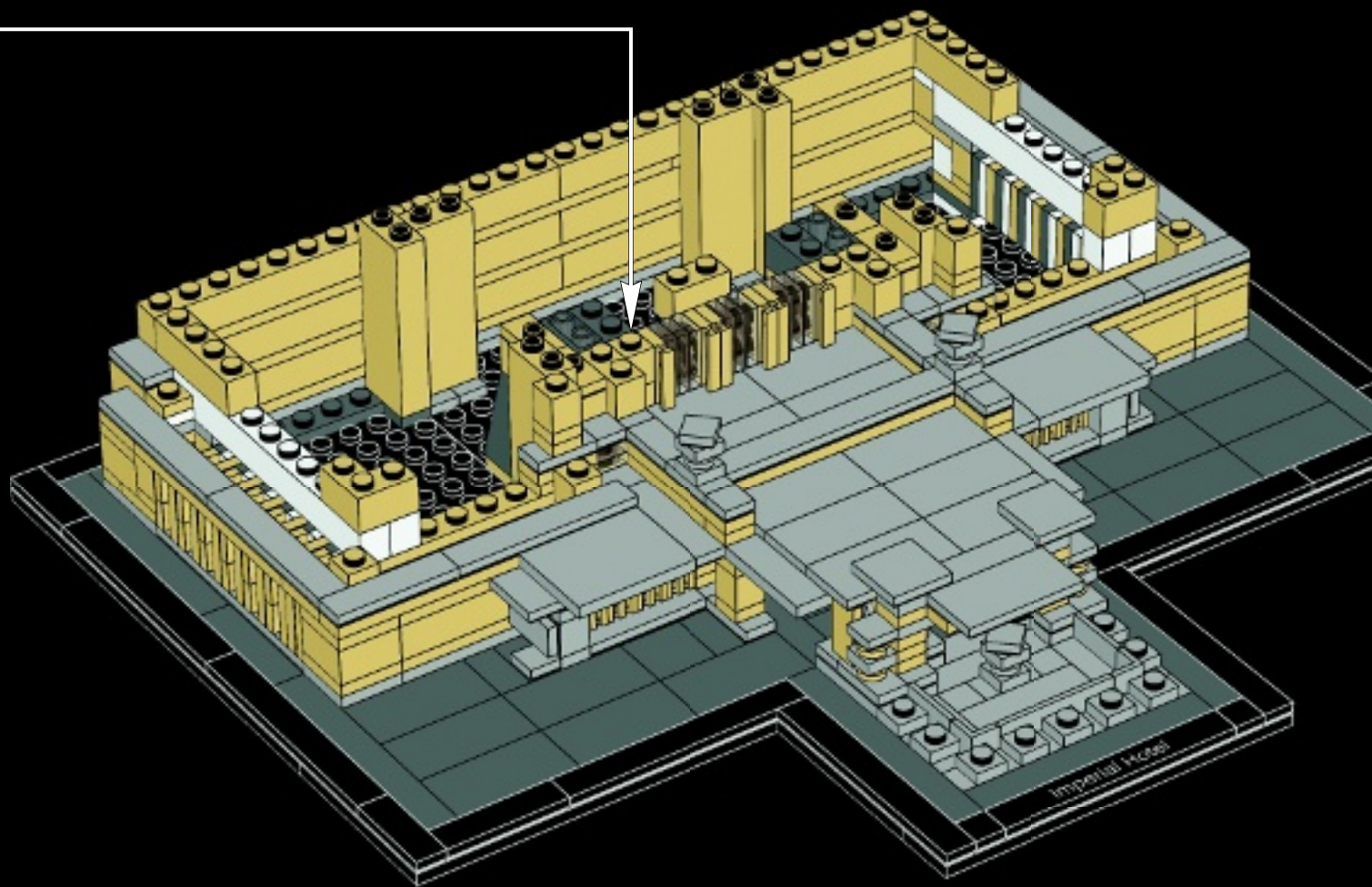

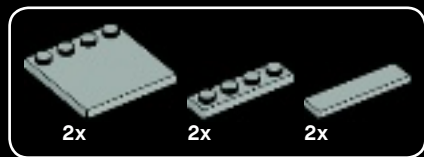

73

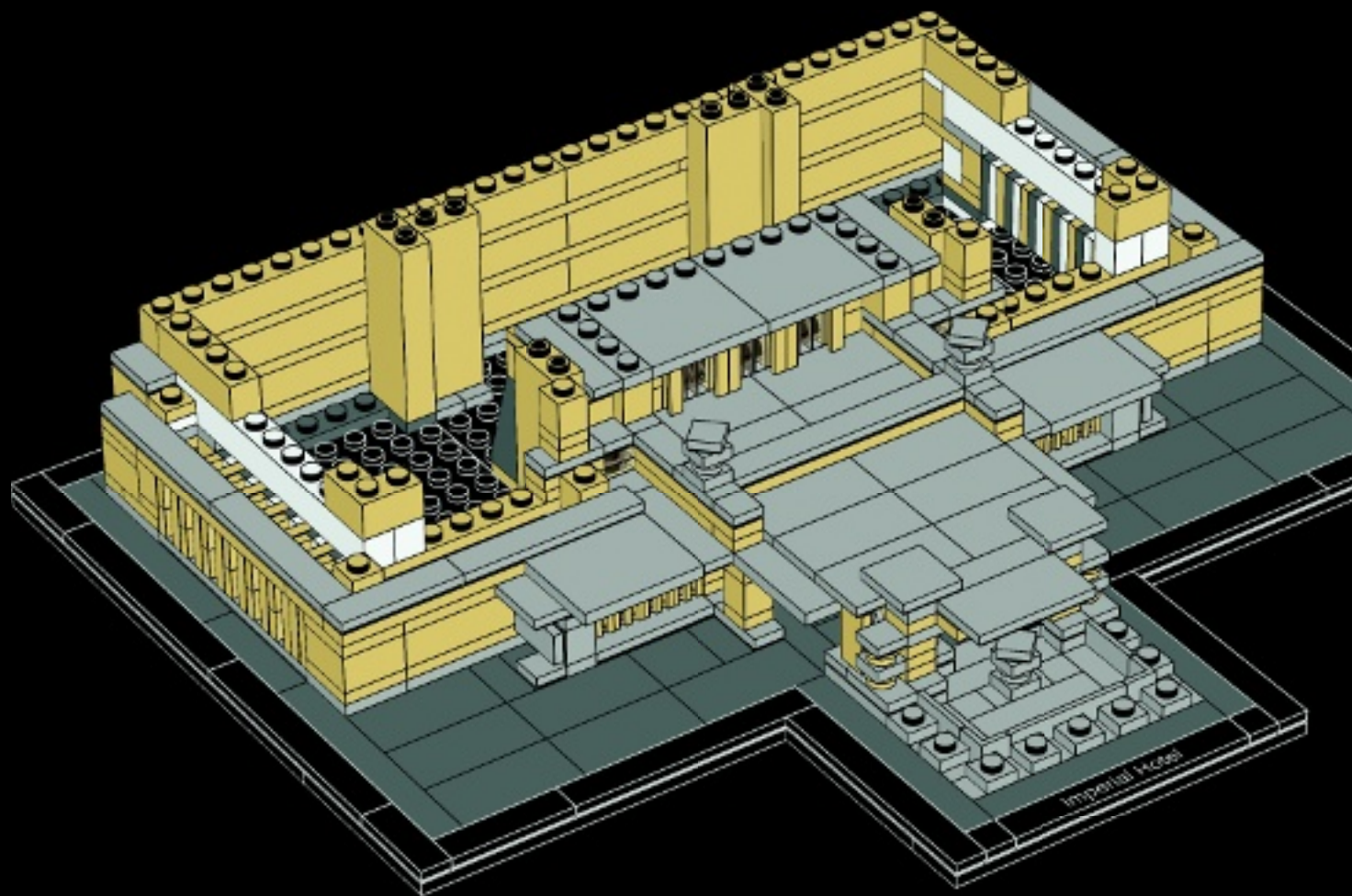



74

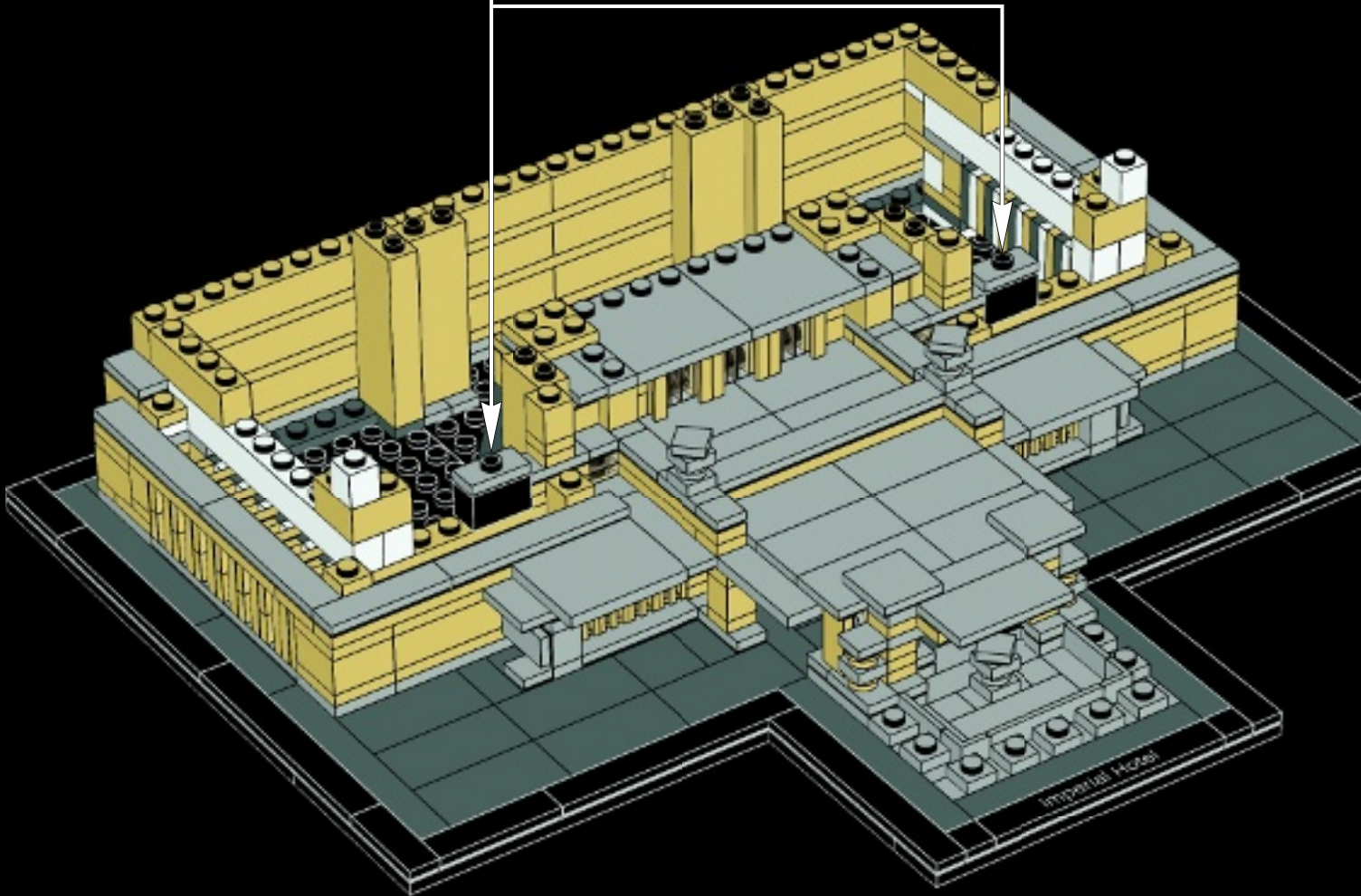
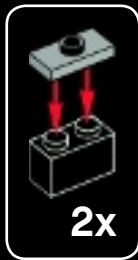

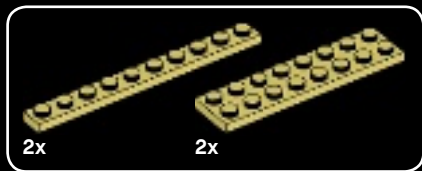

75

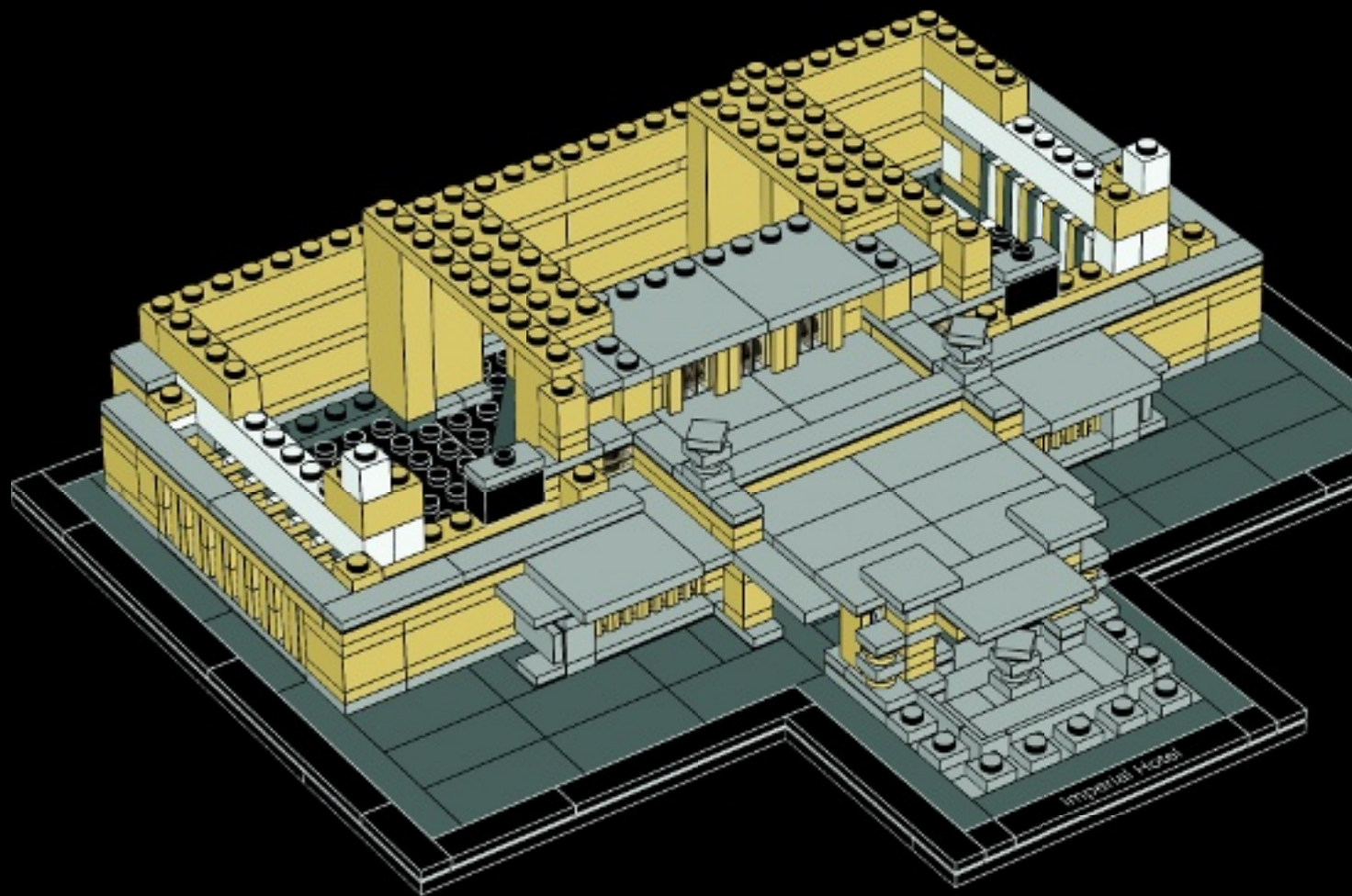



18x



18x

76



6x

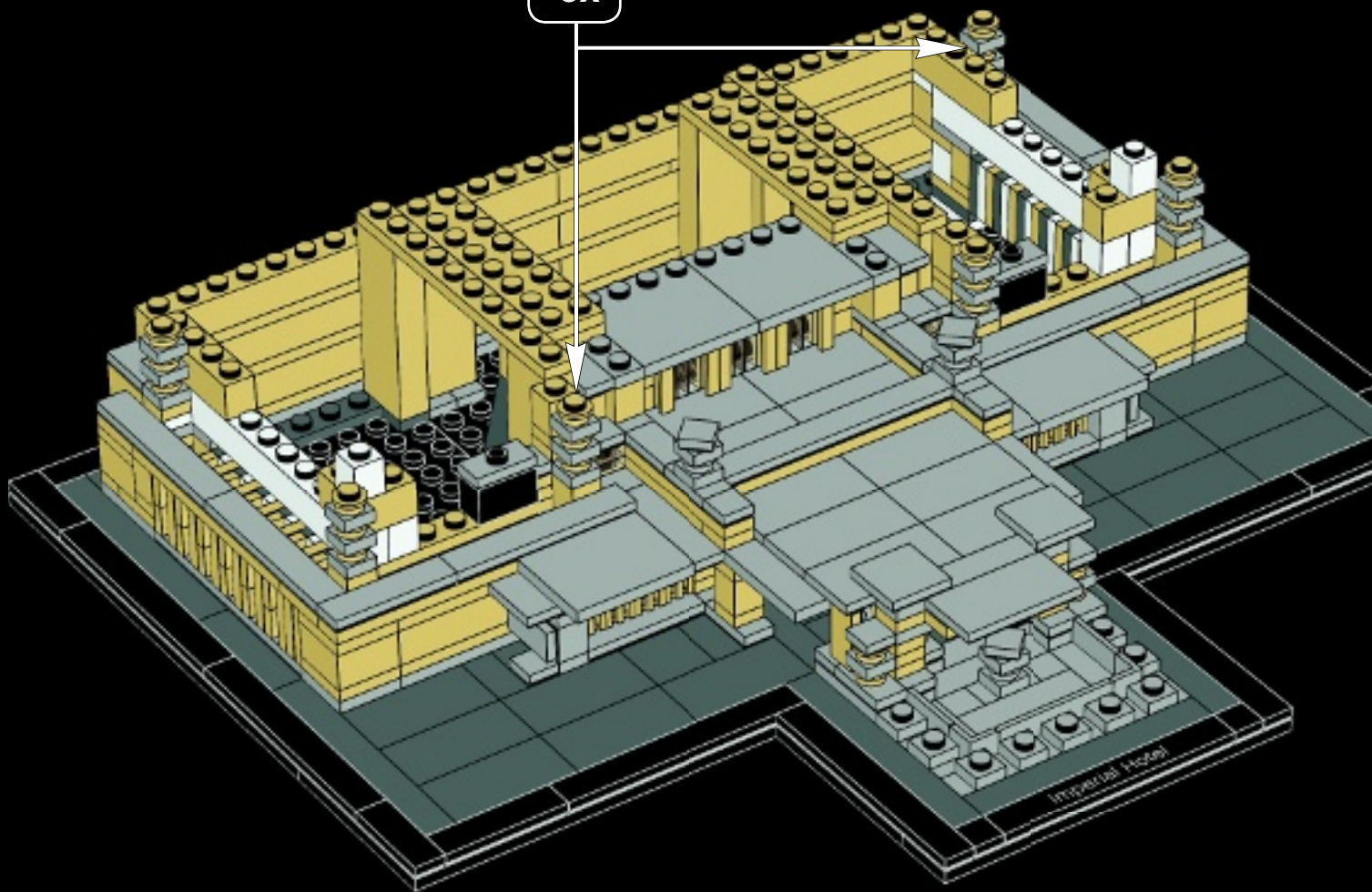



4x



2x

77

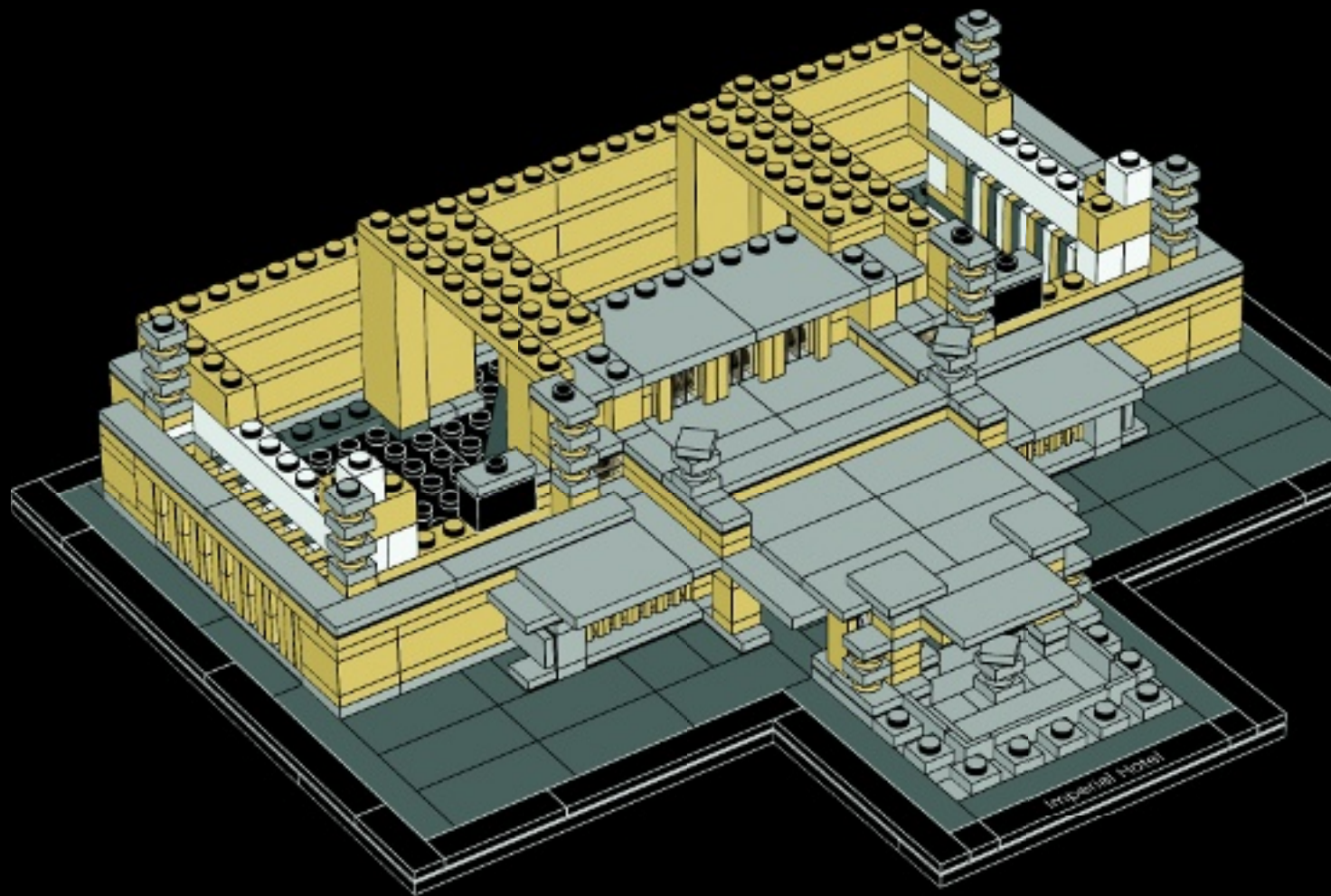

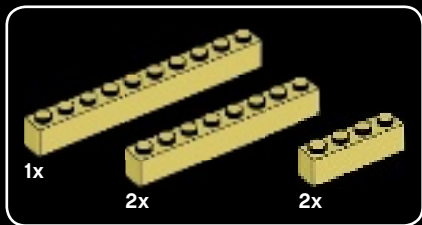

78

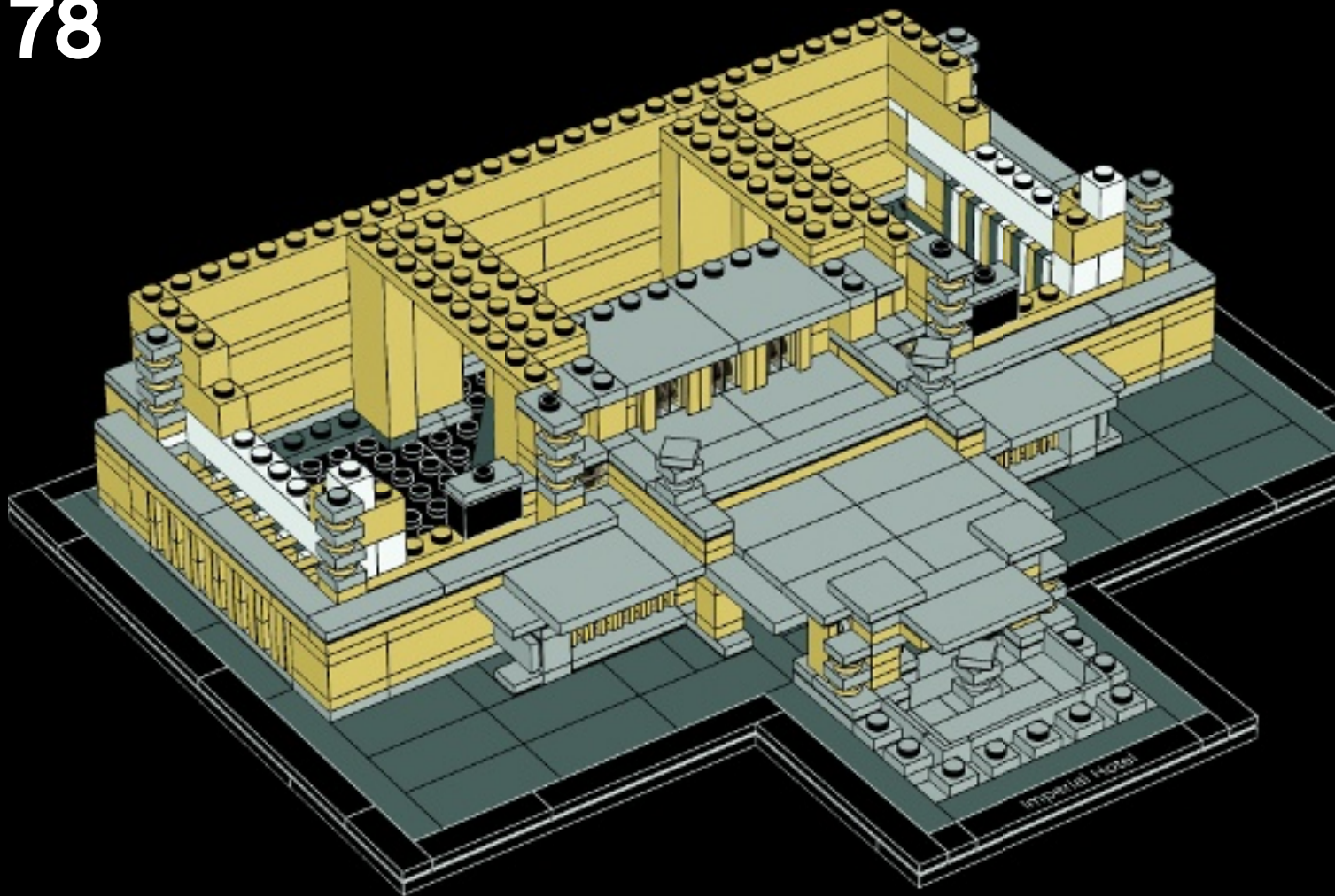



79

1

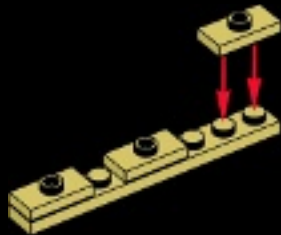

2

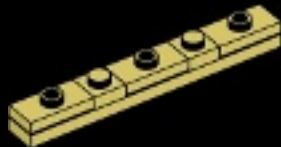

3

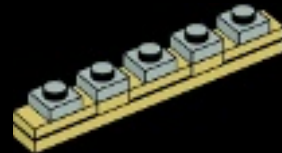

4



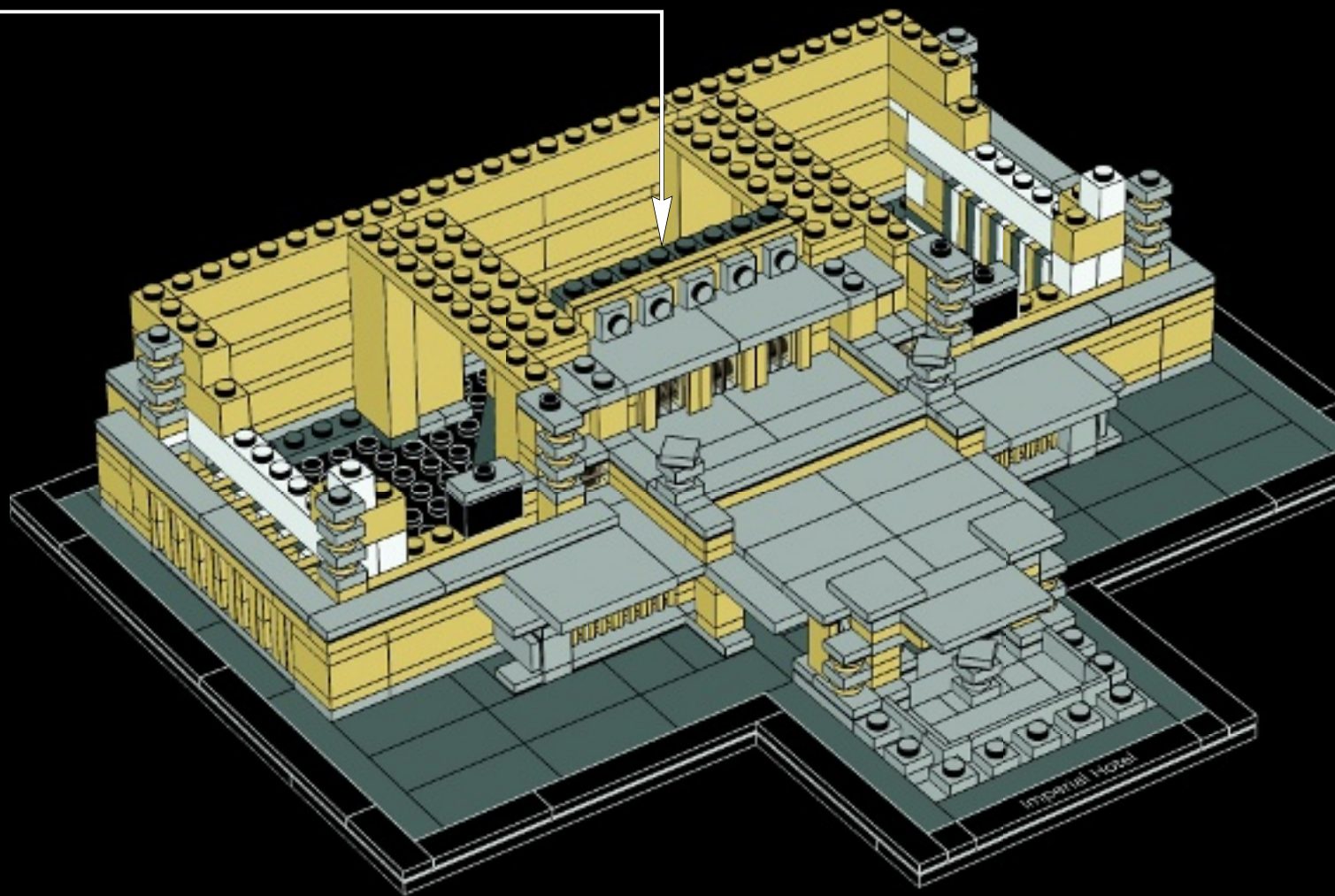



80

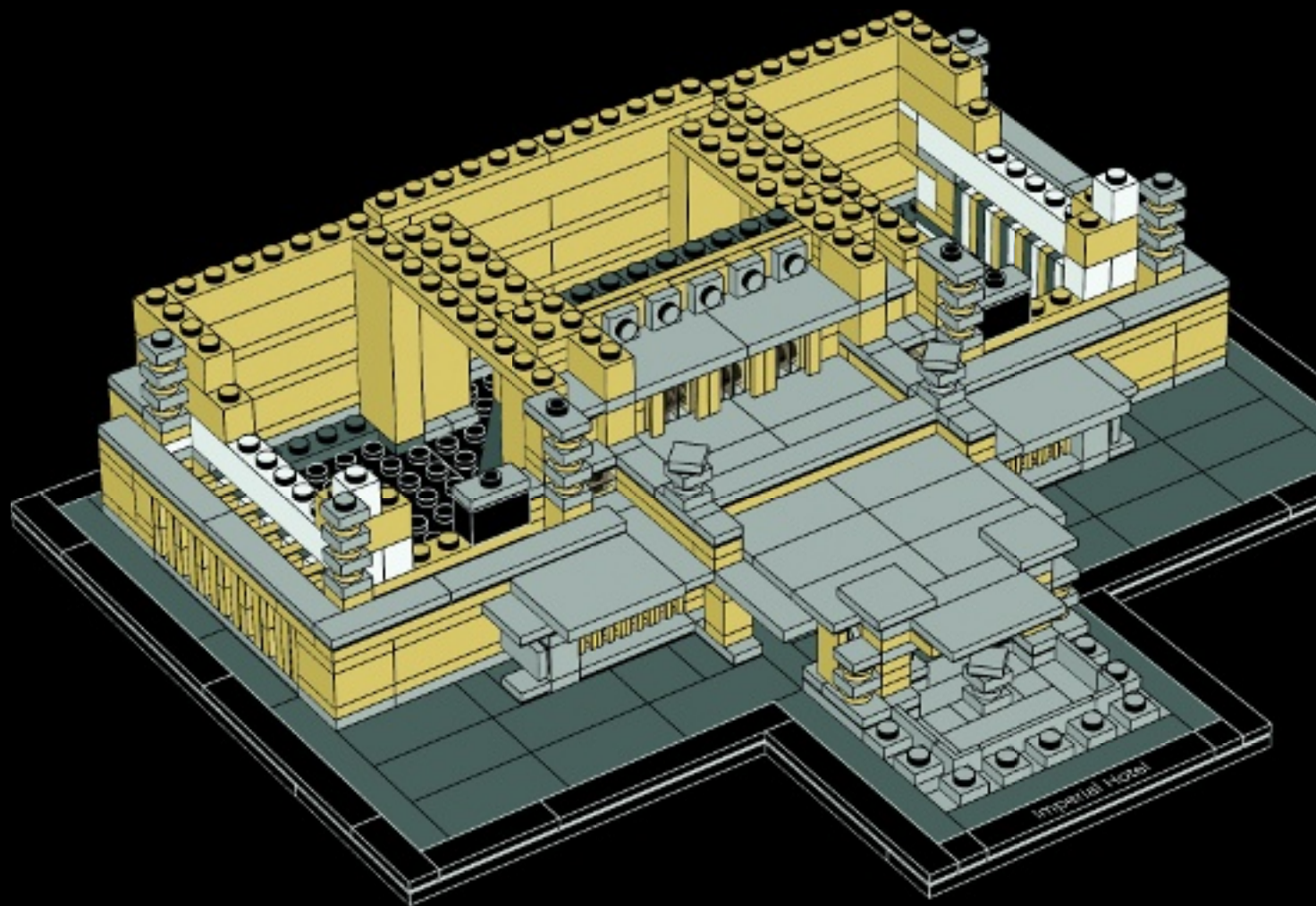

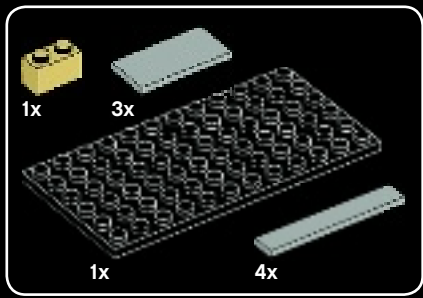

81

1

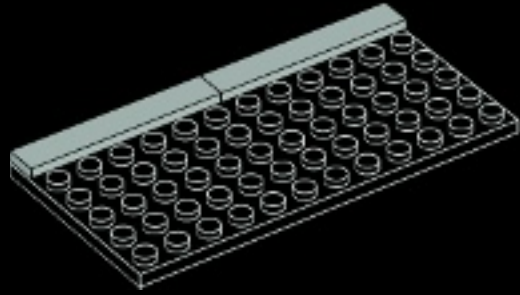

2

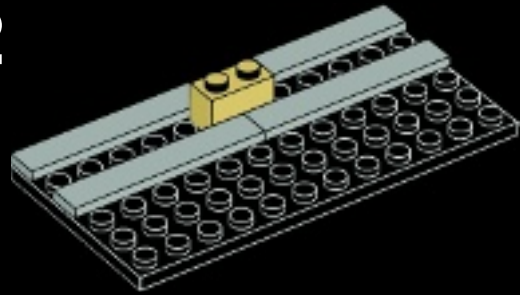

3

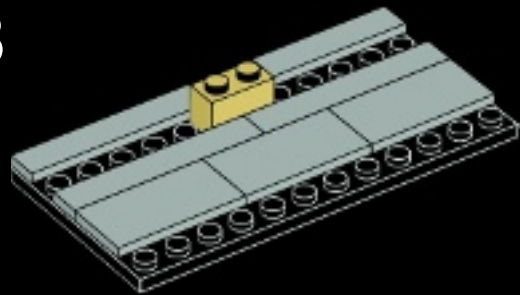

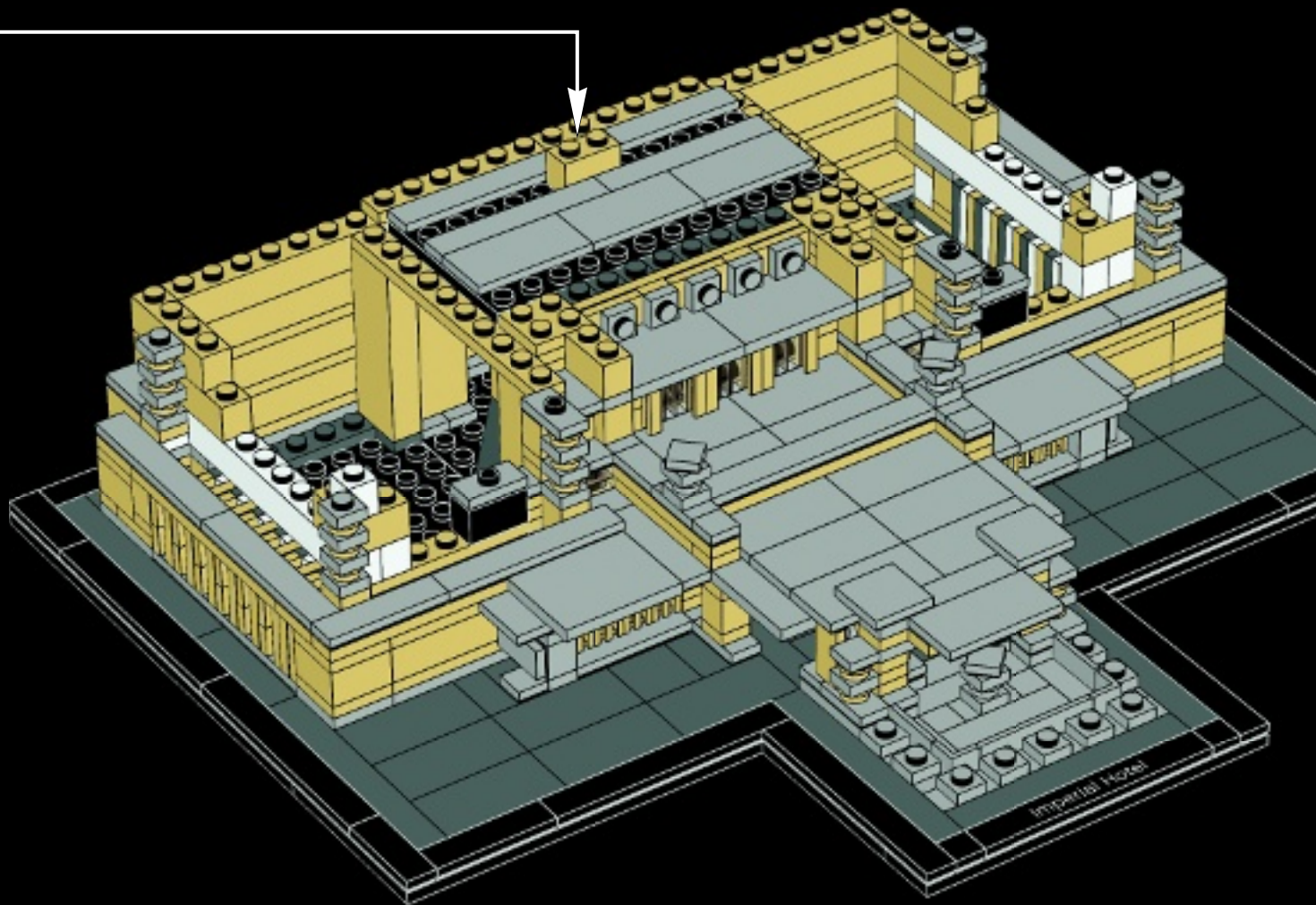

The Great Kanto earthquake of September 1st 1923 was most powerful one ever recorded at that time. It measured 7.9 on the magnitude scale.

Le tremblement de terre de Kanto du 1er septembre 1923 fut le plus puissant jamais enregistré à cette époque. Il avait une amplitude de 7,9 sur l'échelle de Richter.





82

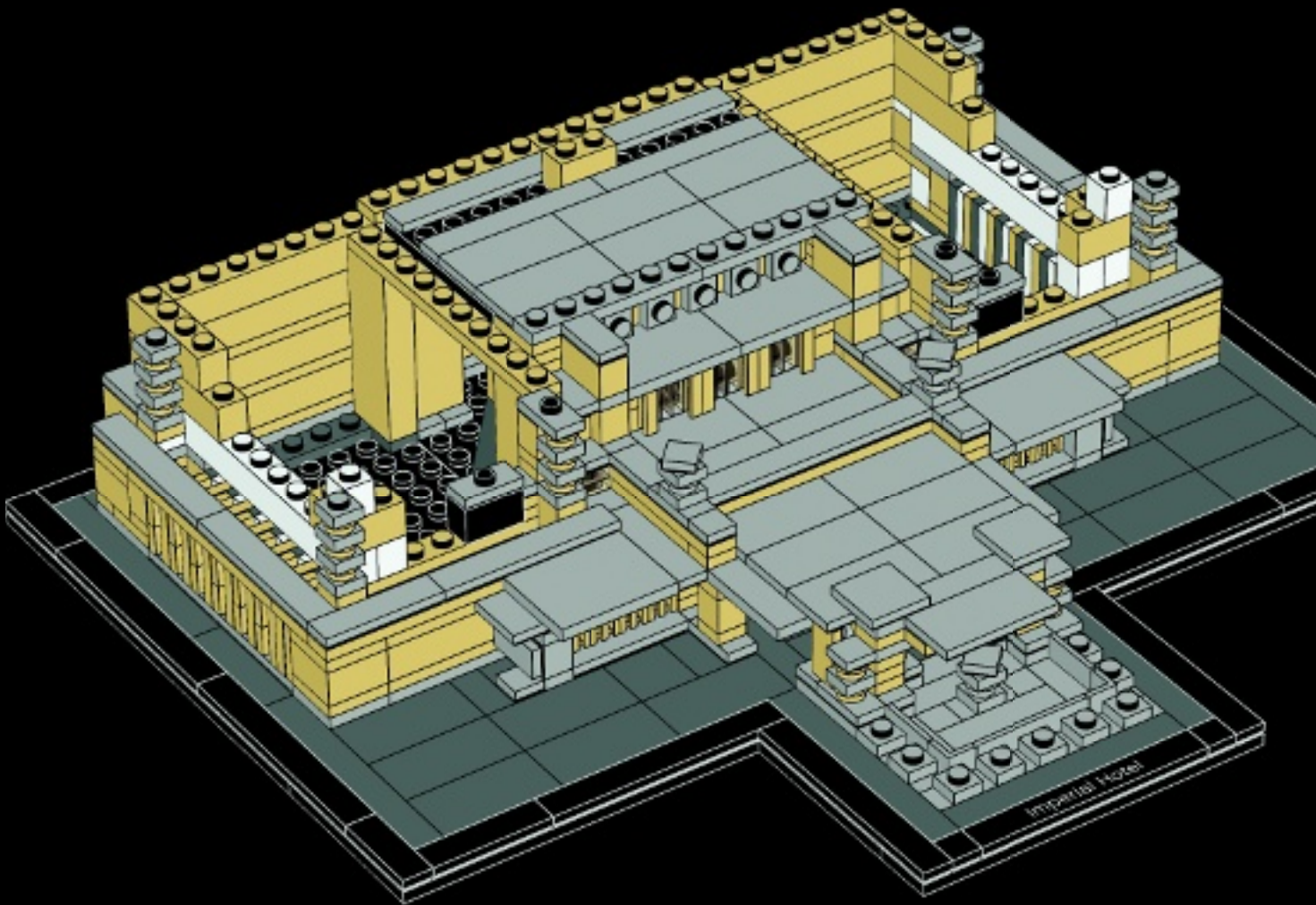



1



2



3

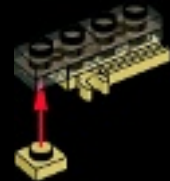

4





5



6



7



8





9



10



11



12

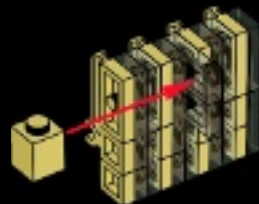

2x

83

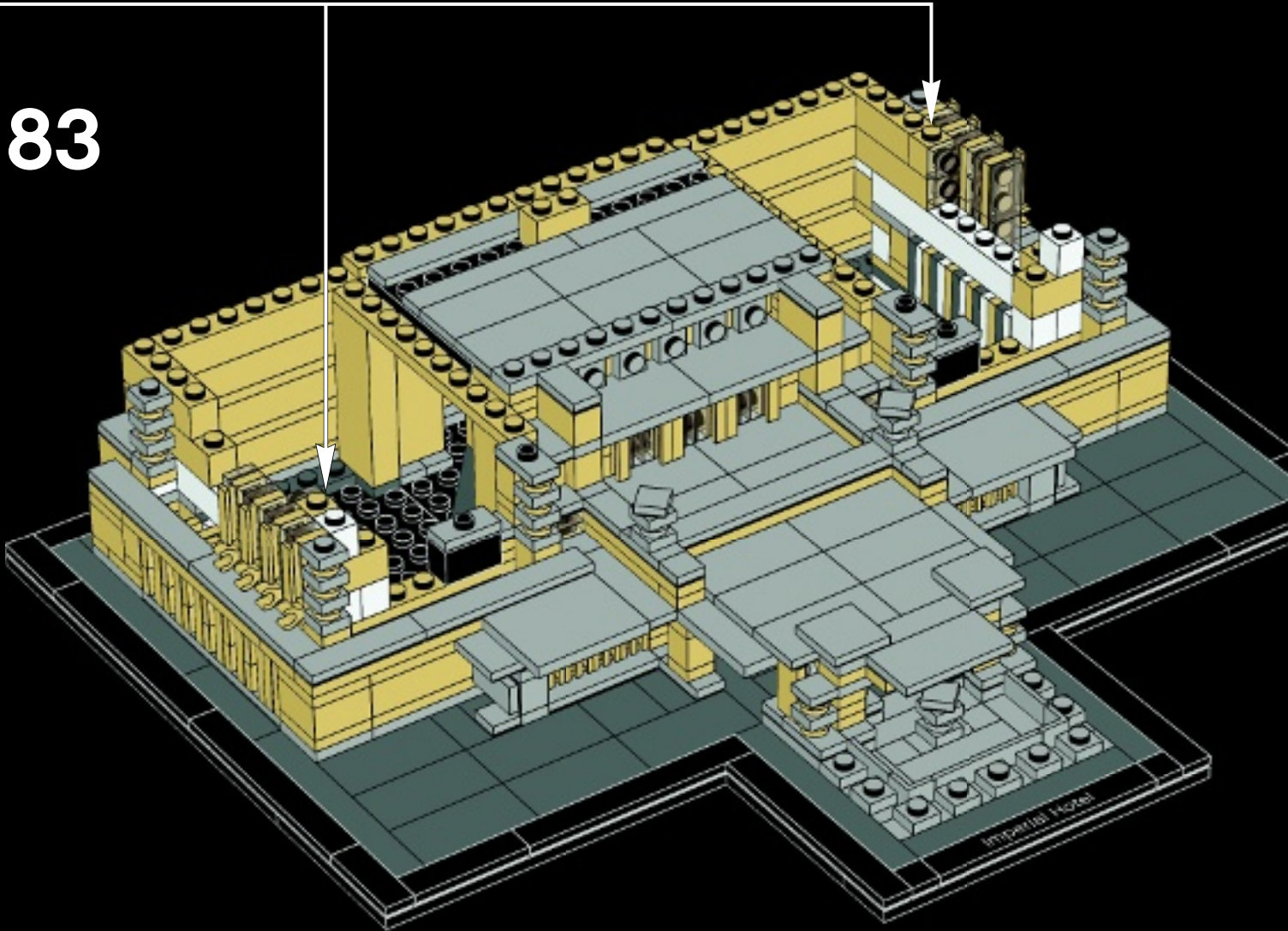



1



2



3



4





5



6



7



8





9



10



11



12

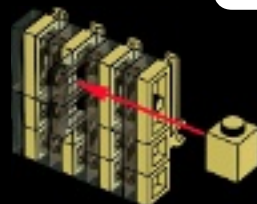

2x

84

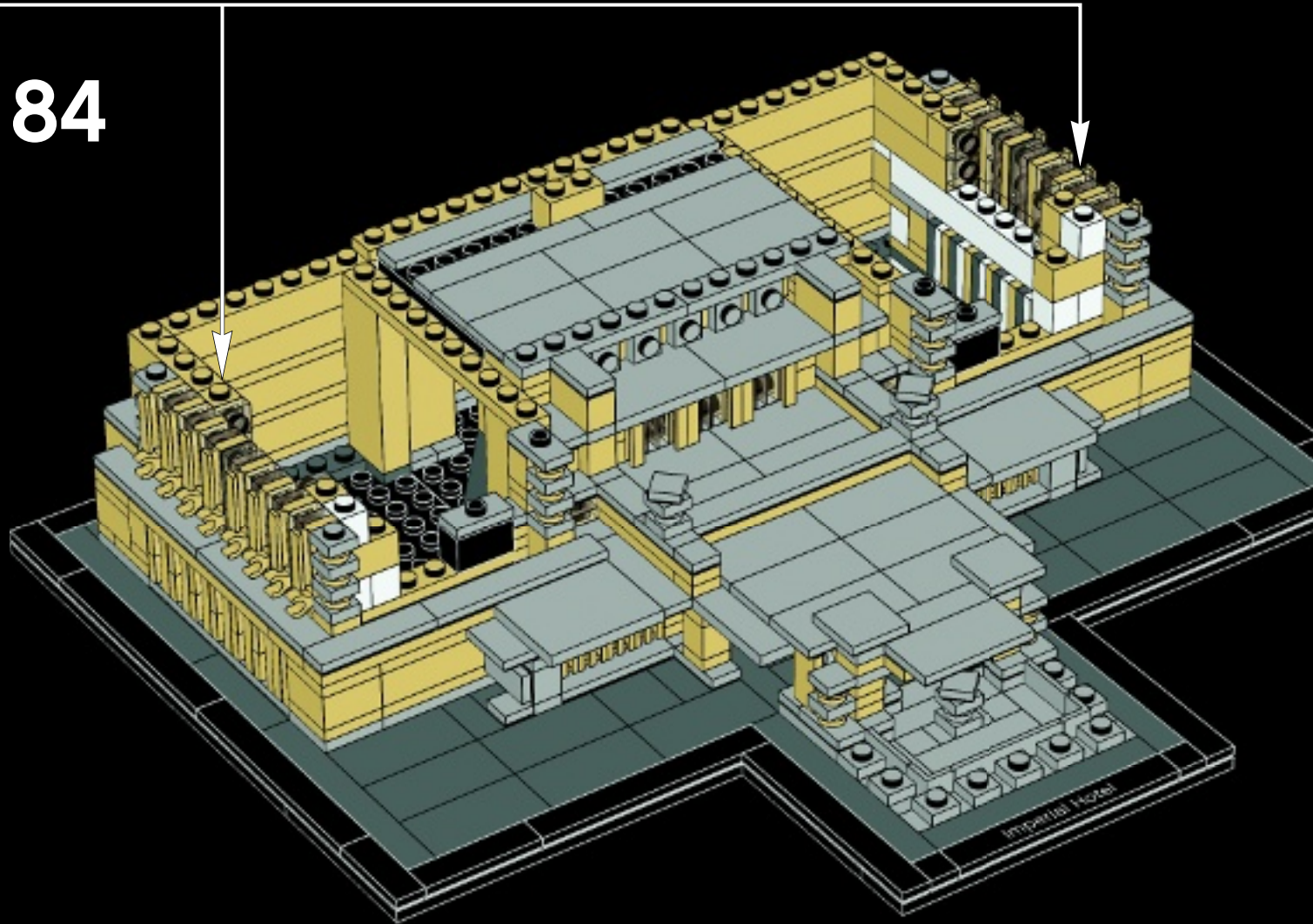



1

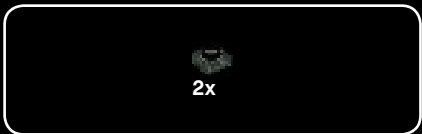

2



3

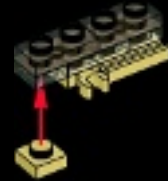

4



5





3x

6



1x



1x



1x

7



2x

8



1x

9

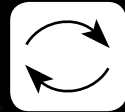
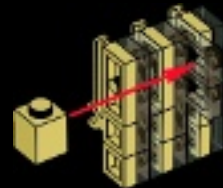

85

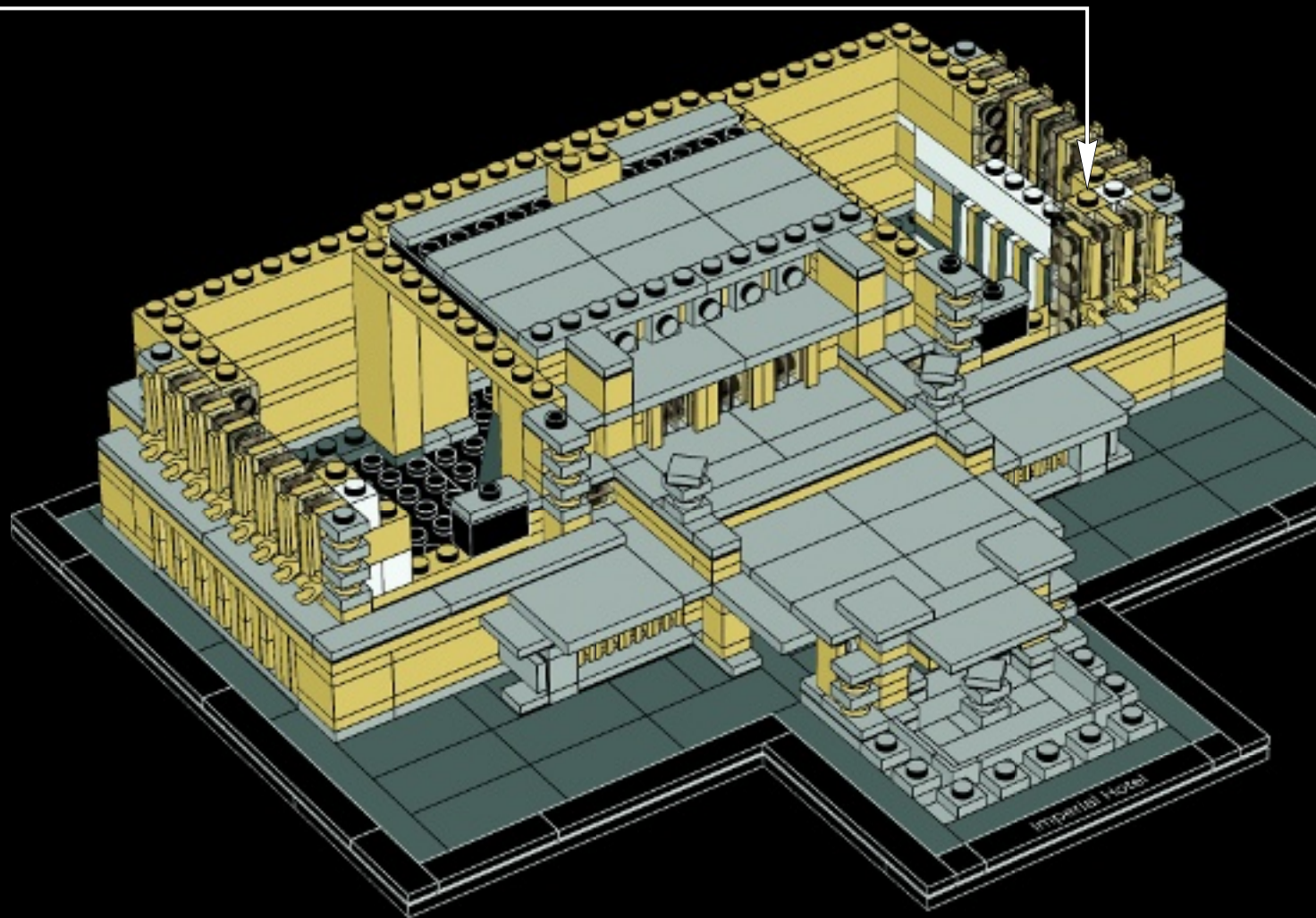



3x

1



2x

2



1x



1x



1x

3



1x



1x



1x

4



1x



2x

5





6



7



8



9

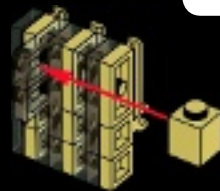

86

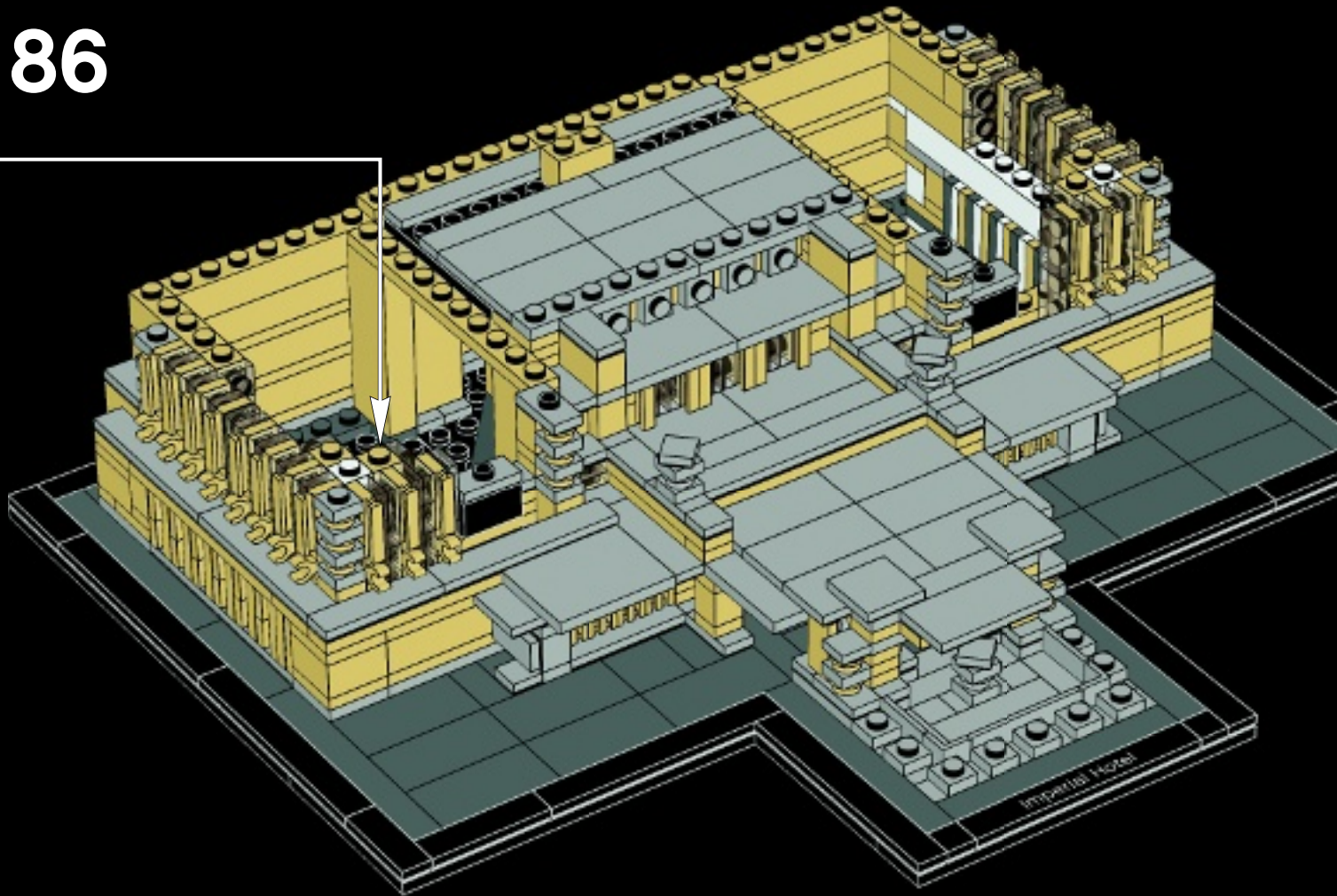



1

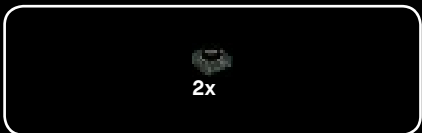

2



3



4



5





3x

6



1x



1x



1x

7



2x

8

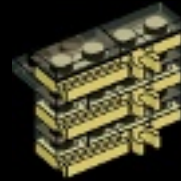

1x

9

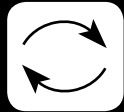

87

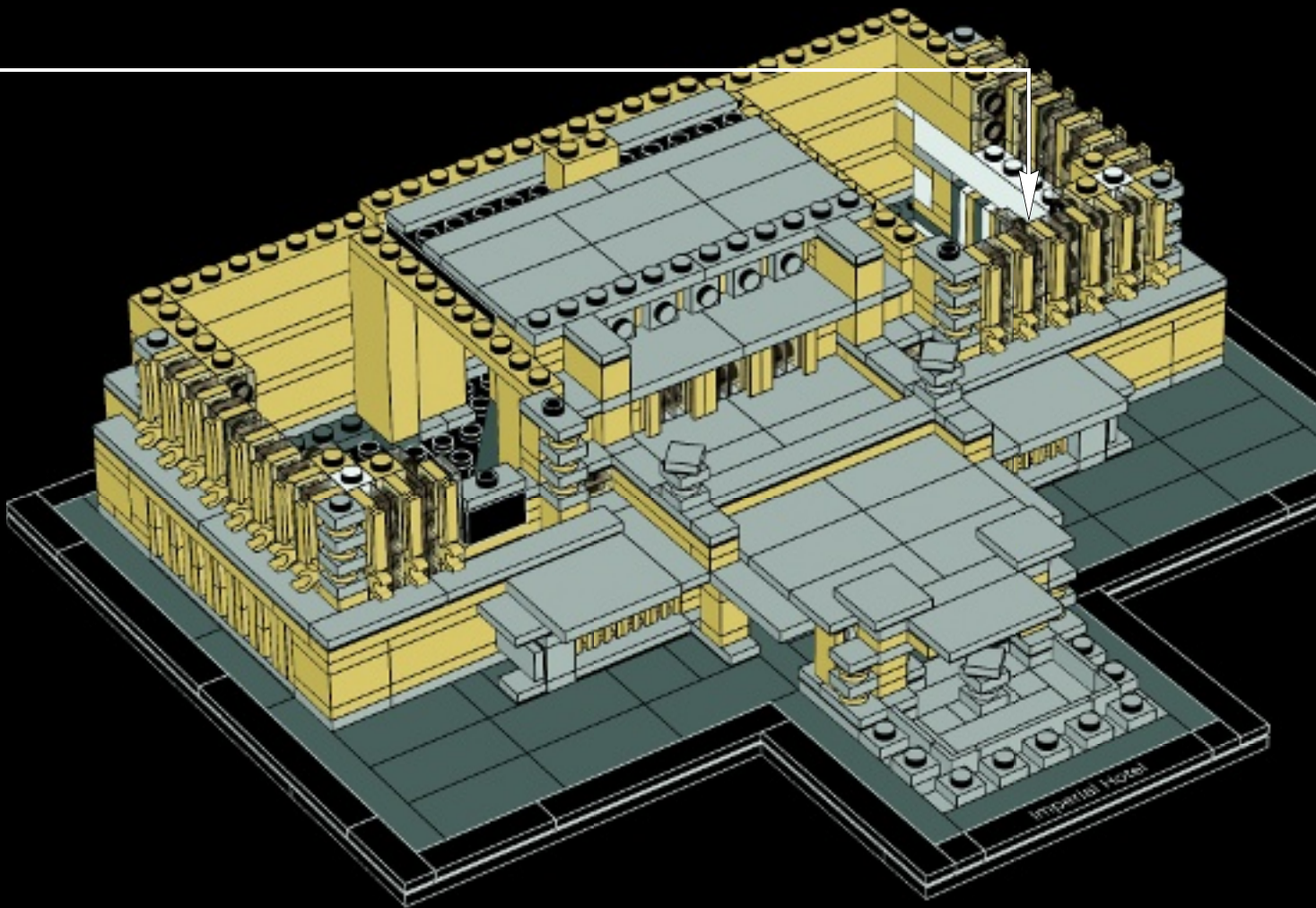



3x

1



2x

2



1x



1x



1x

3

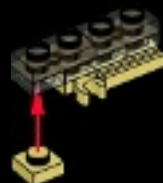

1x



1x



1x

4



1x



2x

5





6



7



8



9

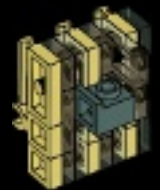

88

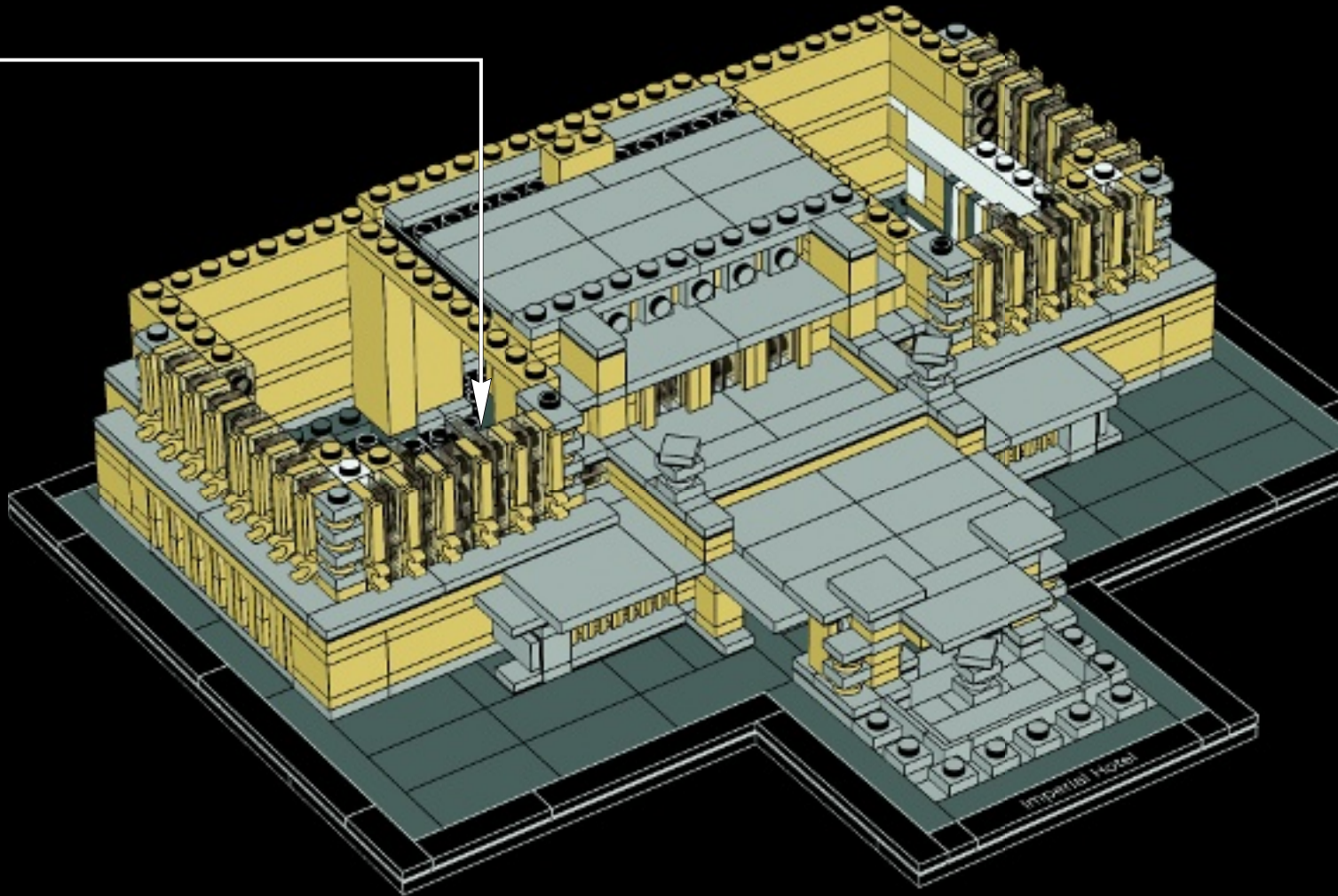



89

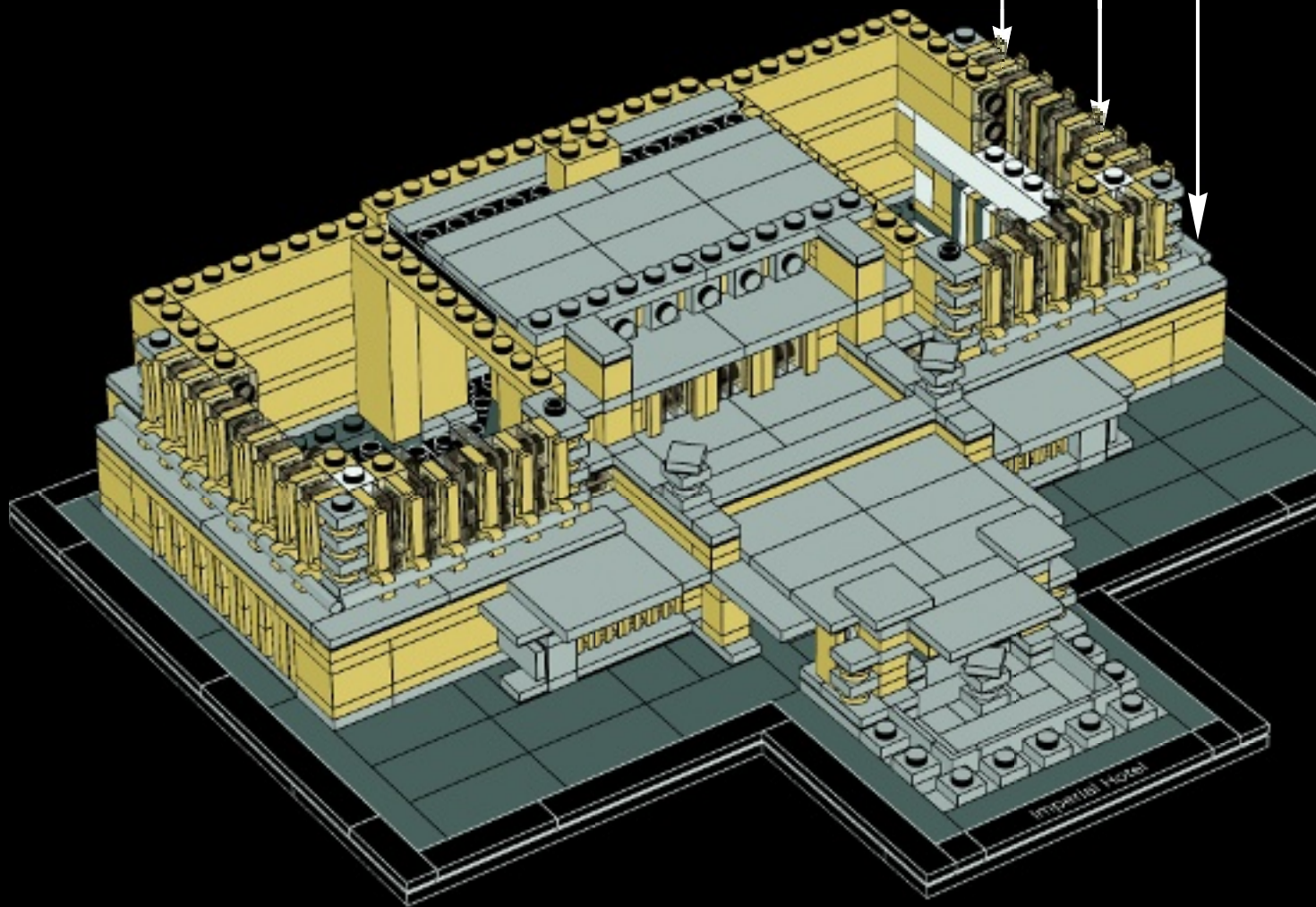



90

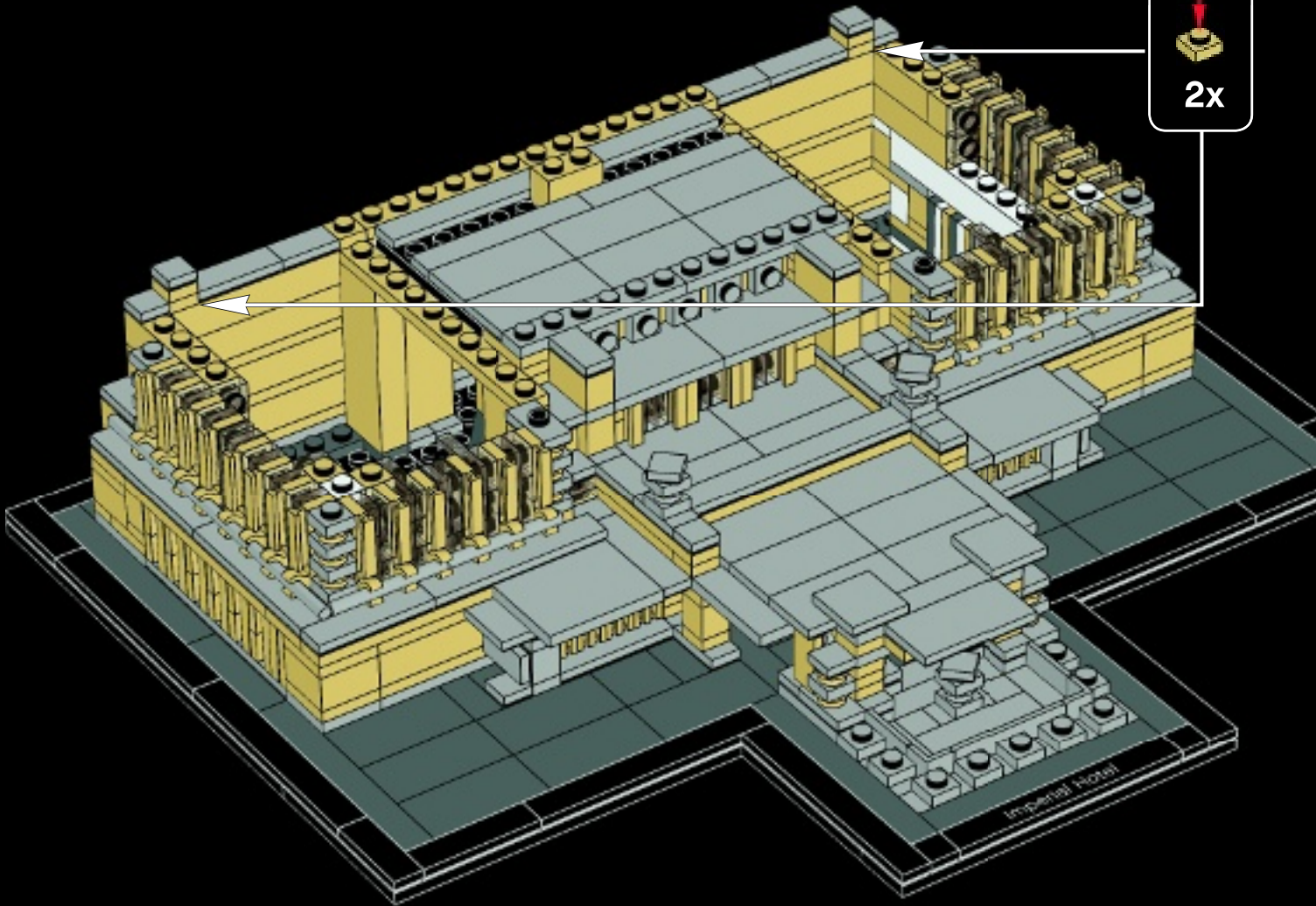

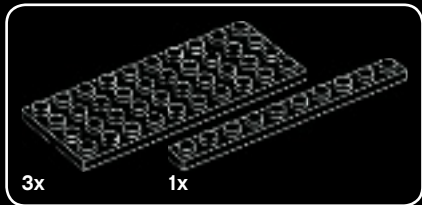

1

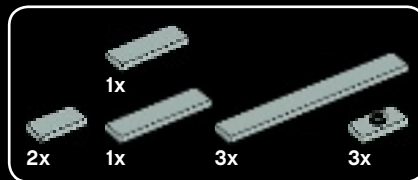
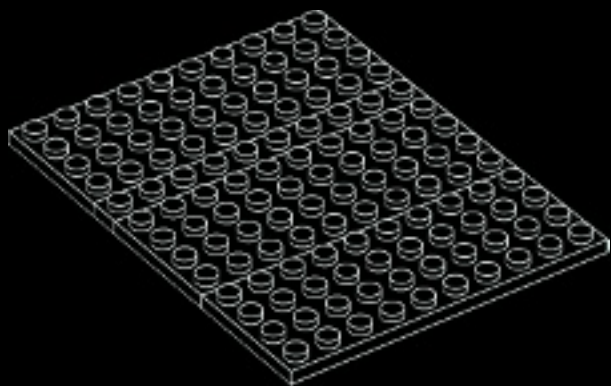

2

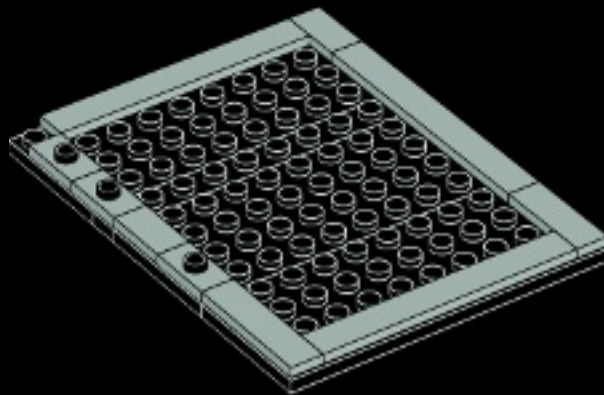

Instead of traditional heavy roof tiles that always caused dangerous debris during earthquakes, Wright opted for a lightweight copper roof.

Au lieu des lourdes tuiles de toit traditionnelles susceptibles de créer des débris dangereux pendant les tremblements de terre, Wright a opté pour un toit plus léger en cuivre.



© Ayuko Yonezumi

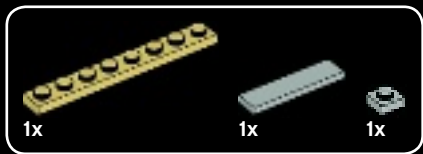

3

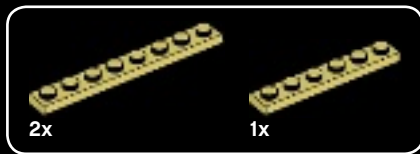
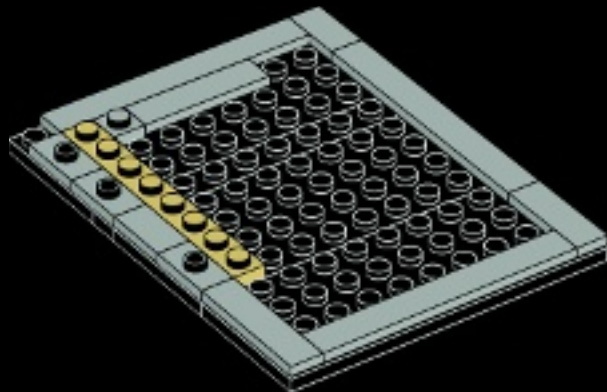

4

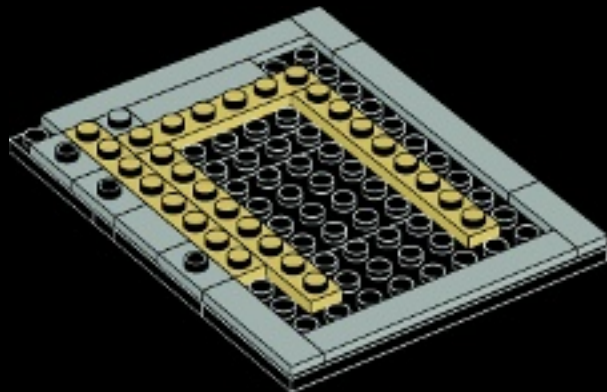



5

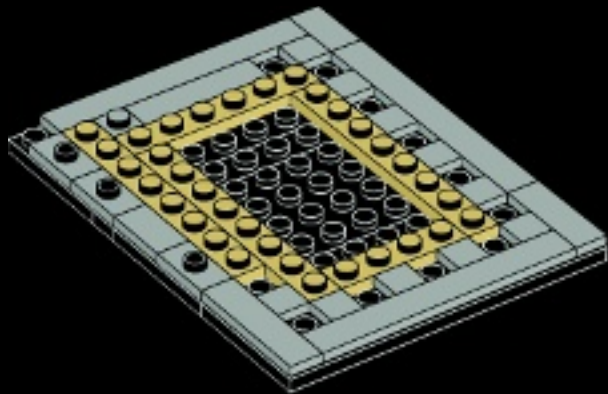

6

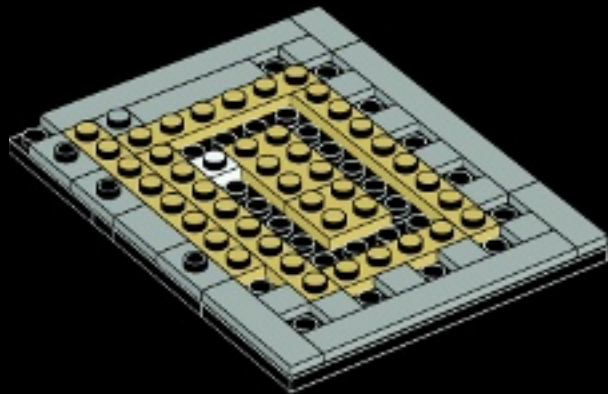



7

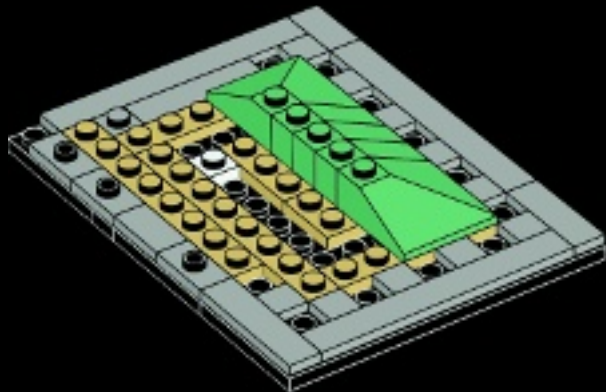

8

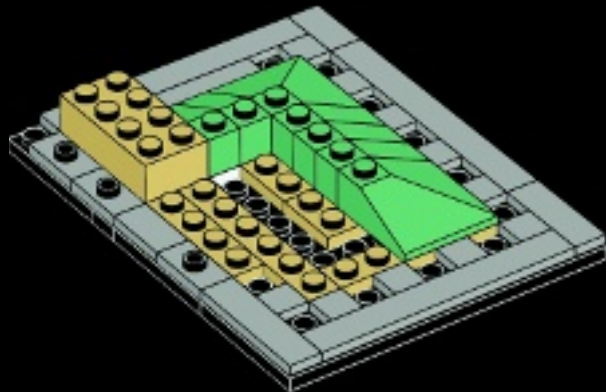



9

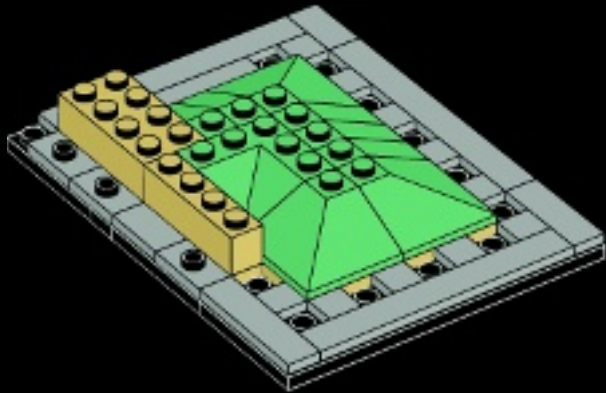

10

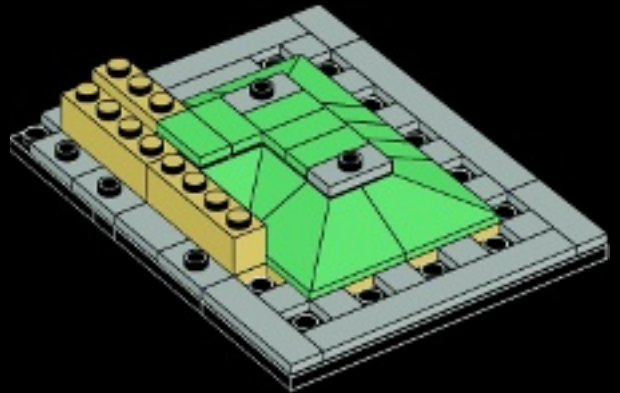



11

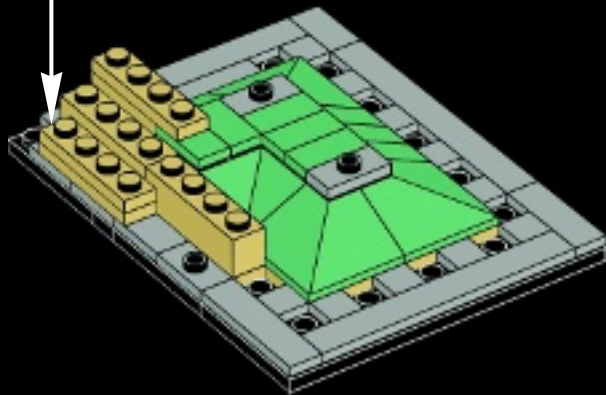
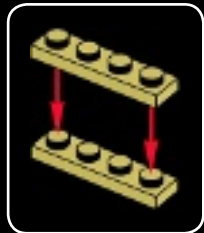

12

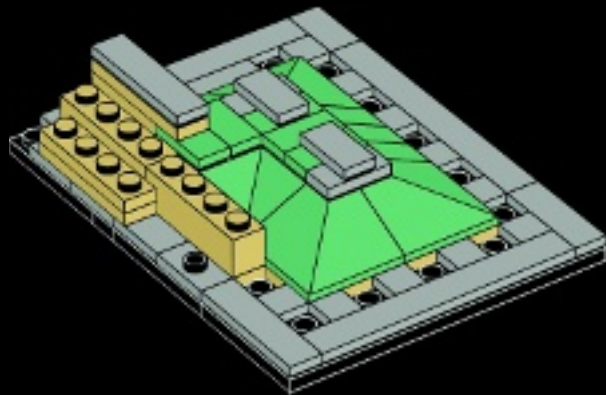

91

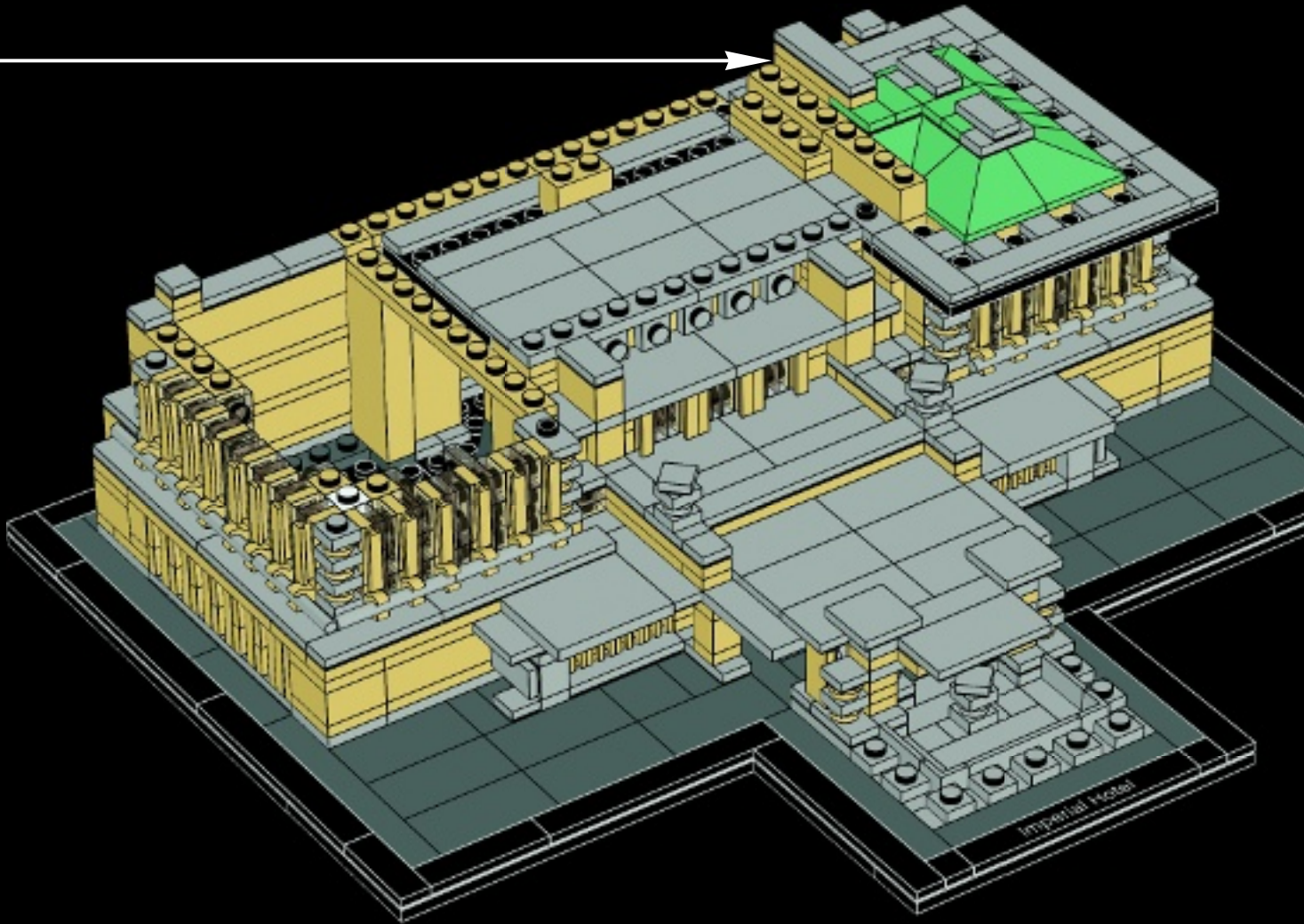

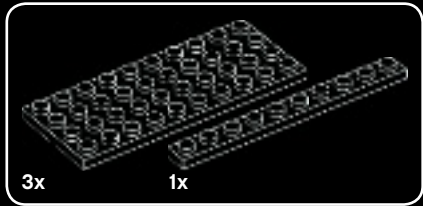
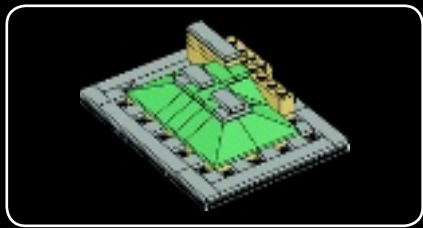

1

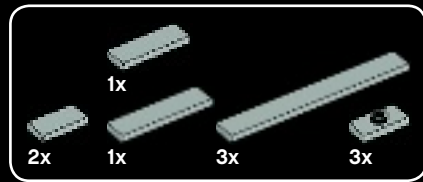
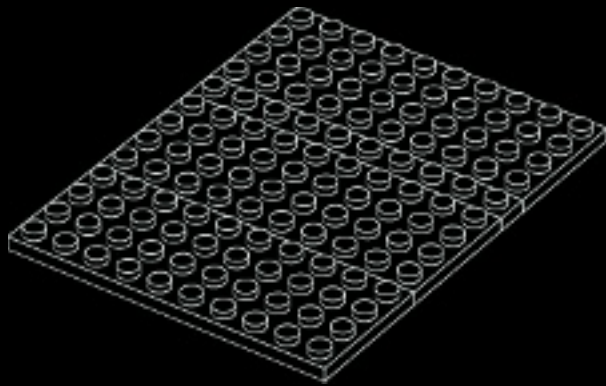

2

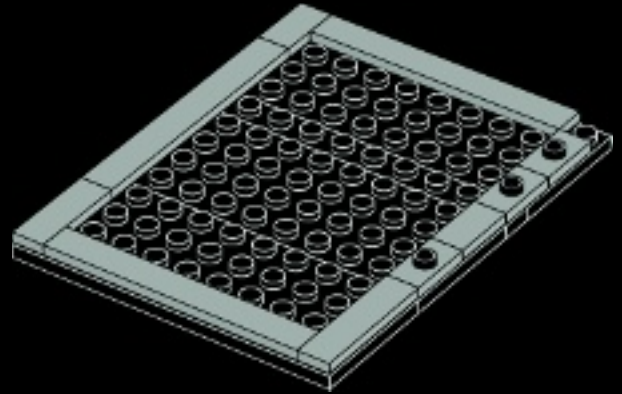

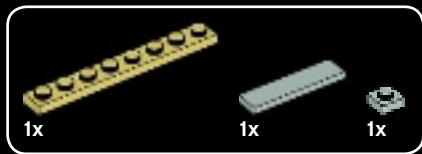

3

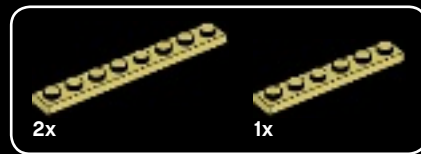
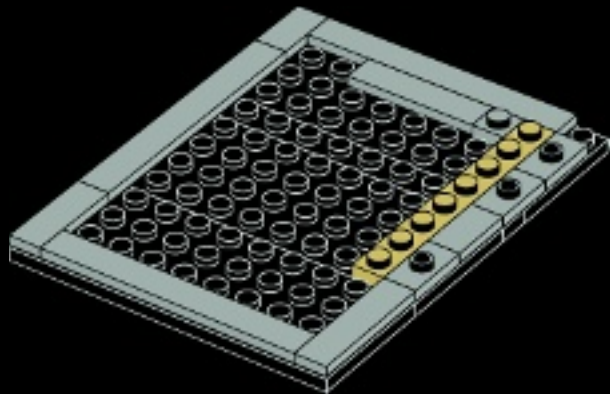

4

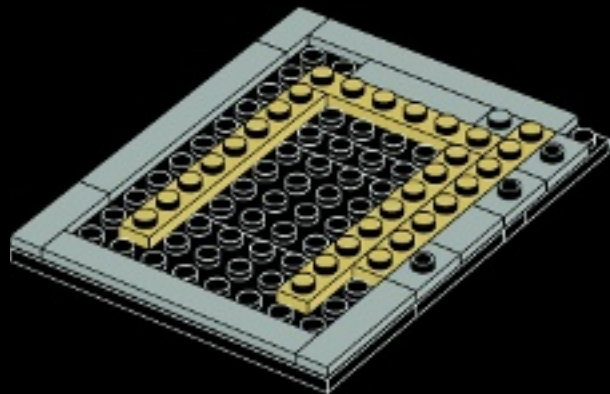



5

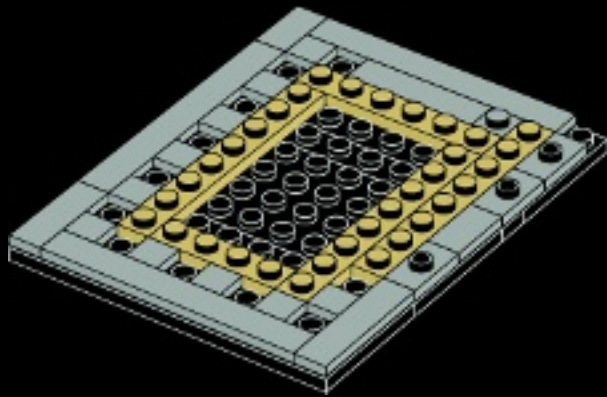

6

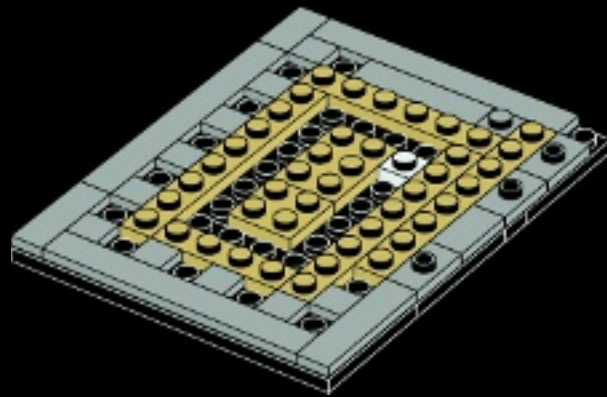



7

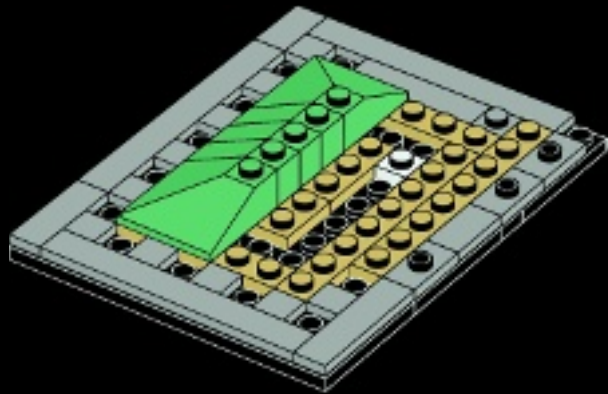

8

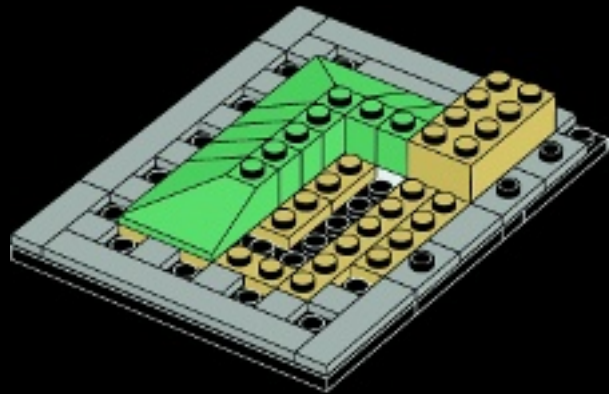



9

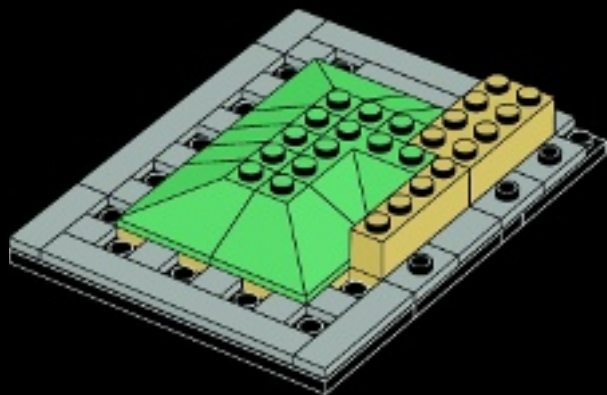

10

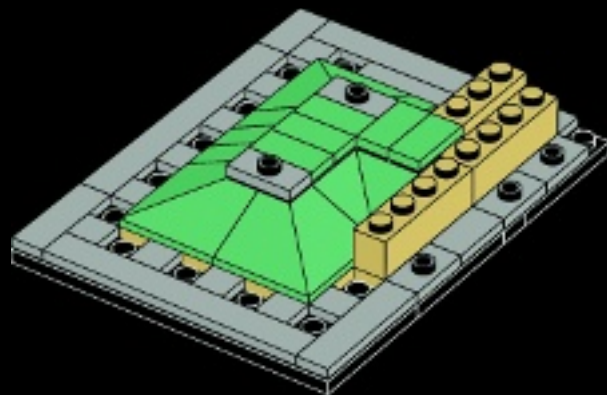



11

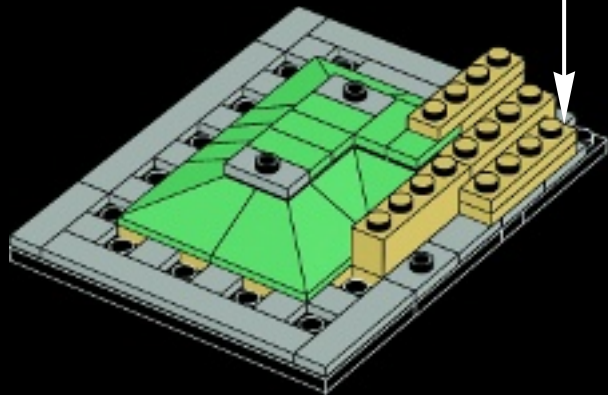
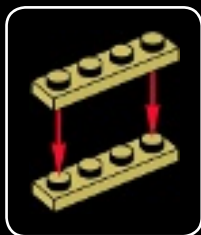

12

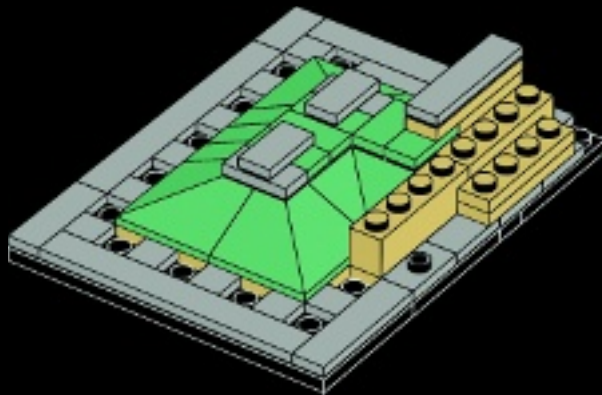

92

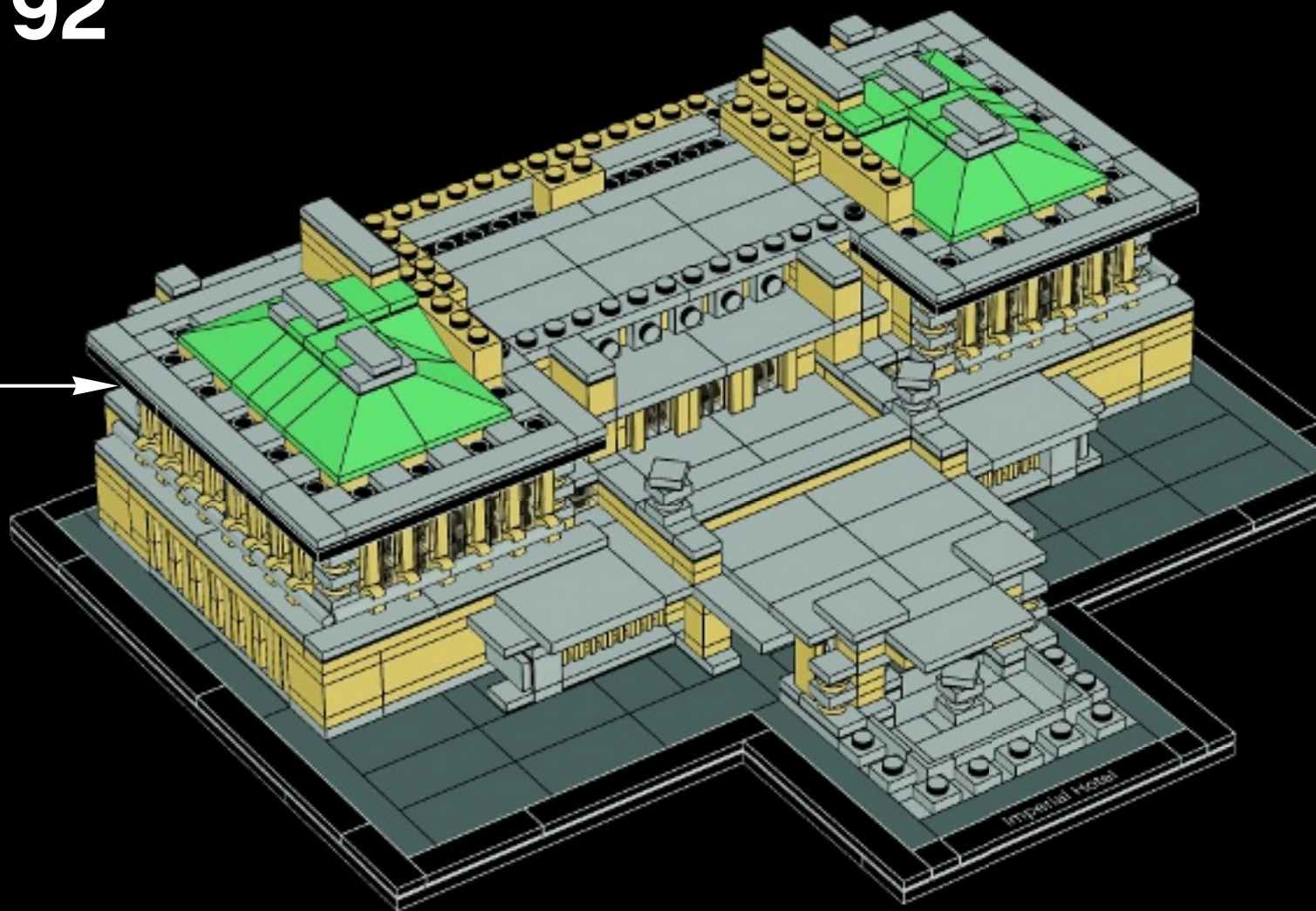

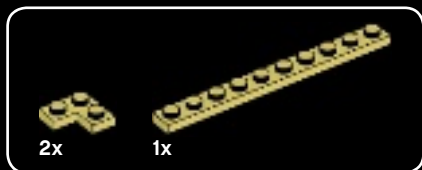

93

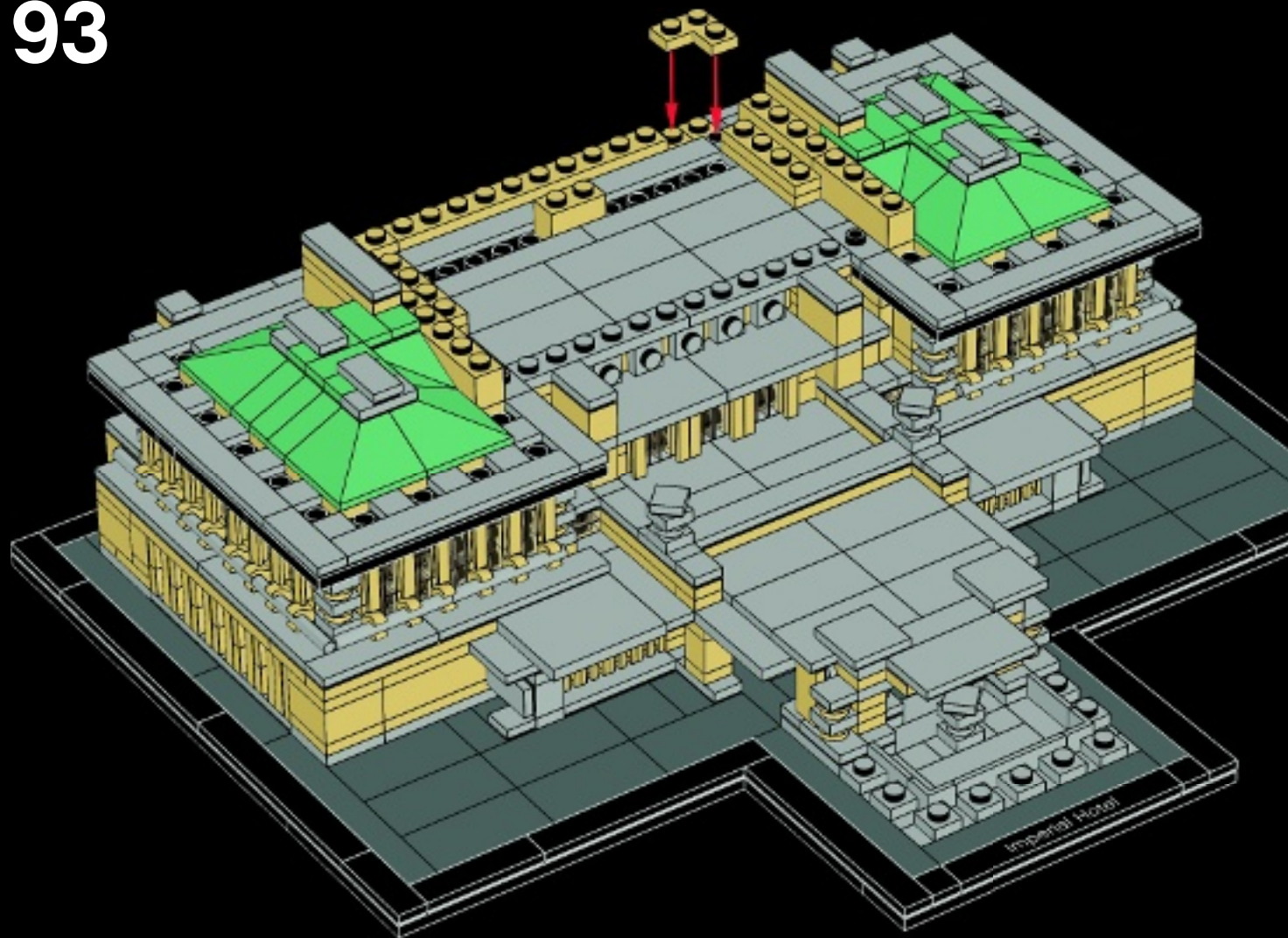

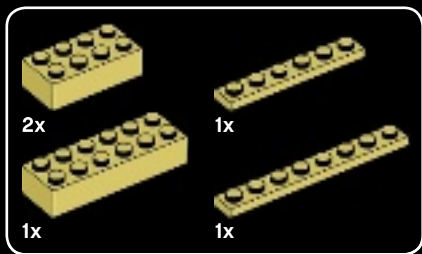

94

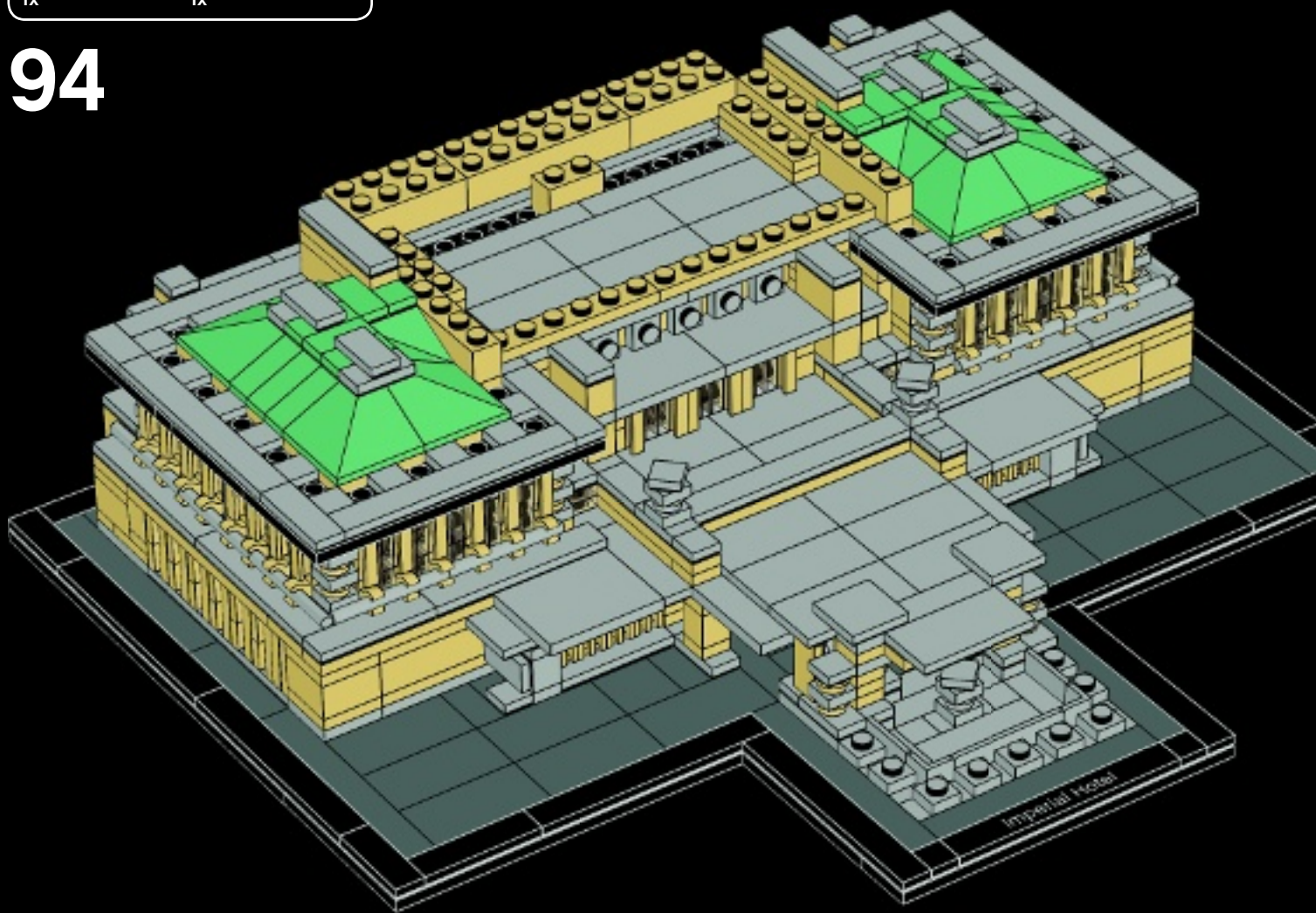



2x



14x

95

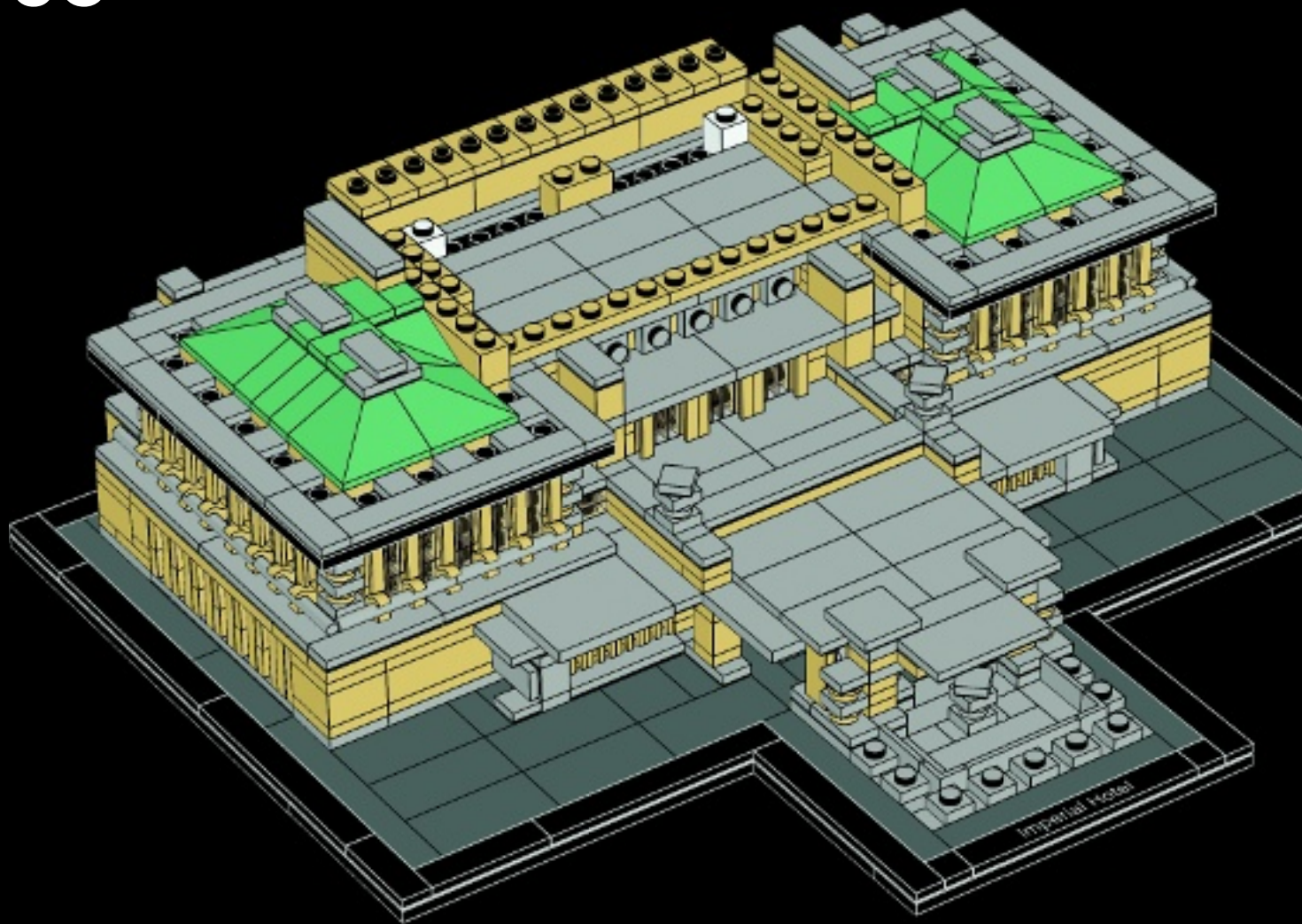

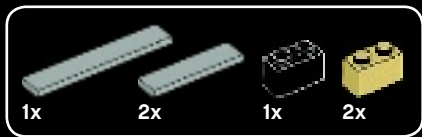

96

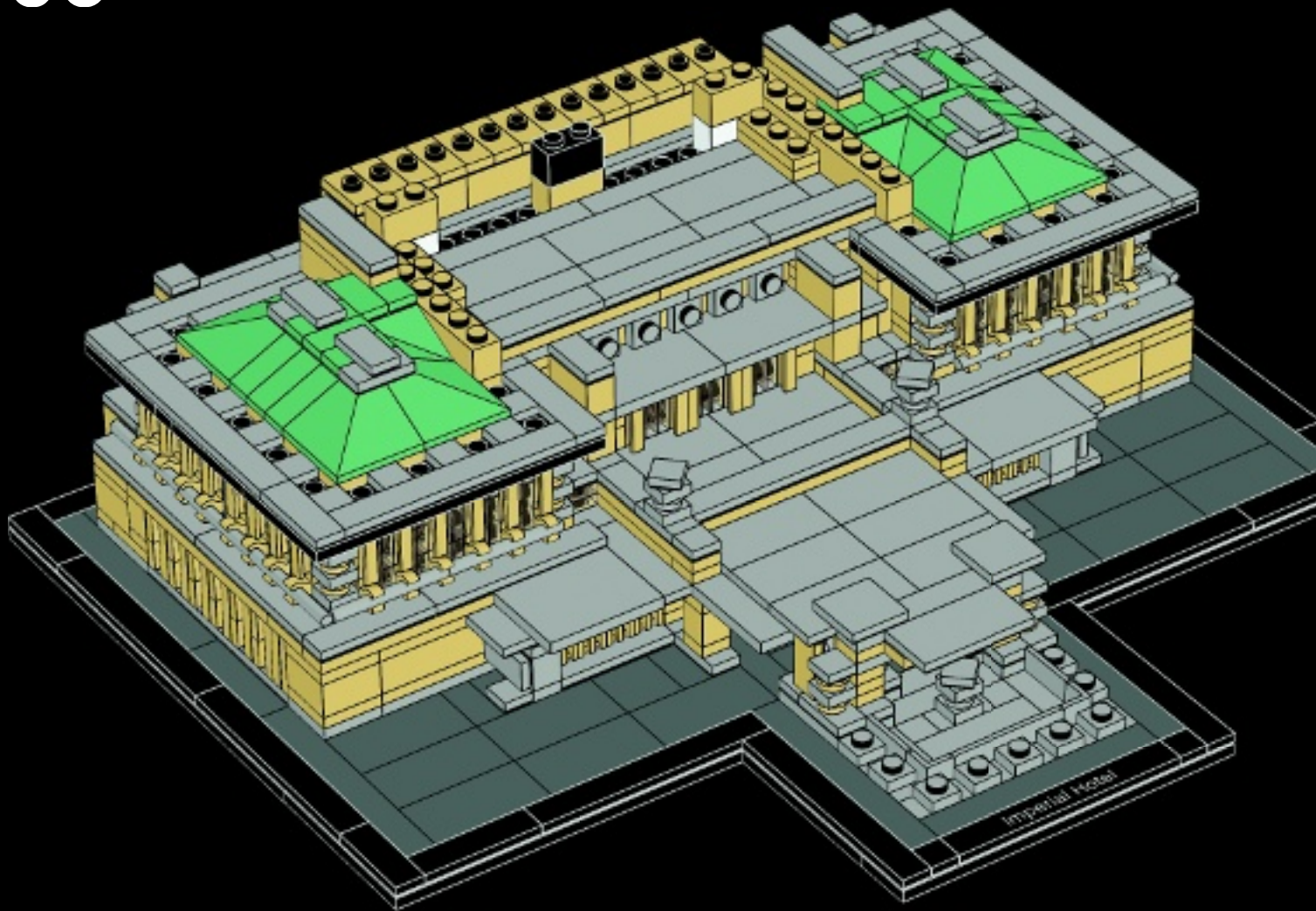



97

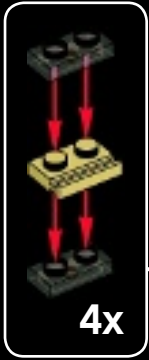

1

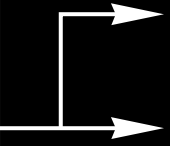

2



3



4

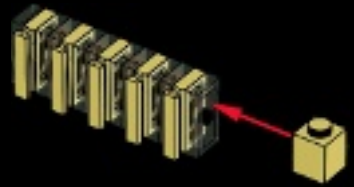
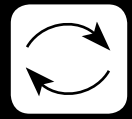

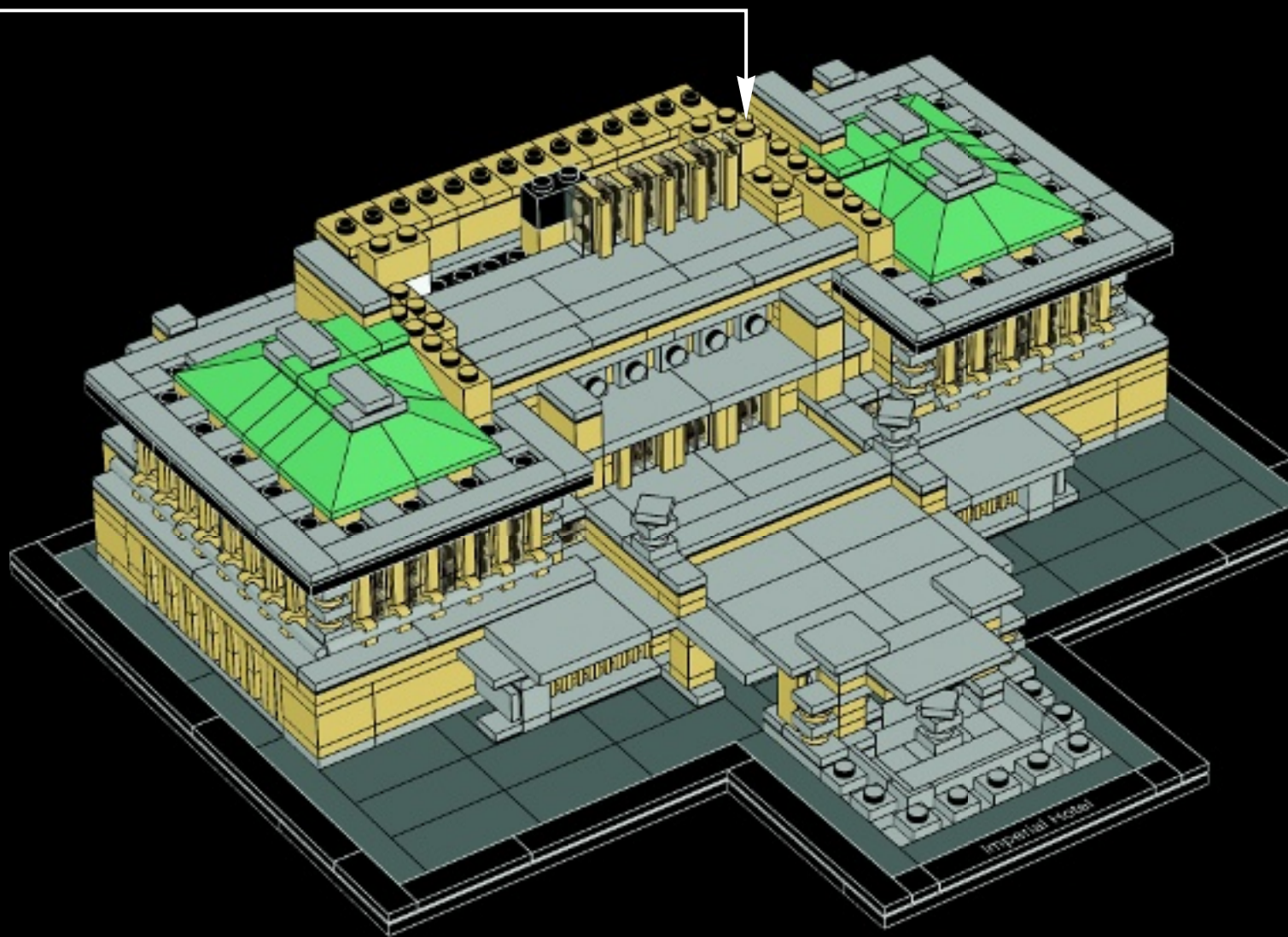



98

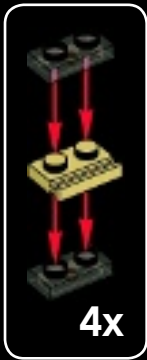

1

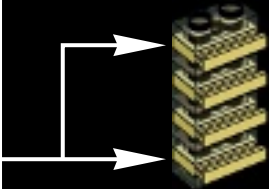

2



3



4

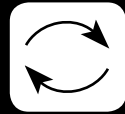

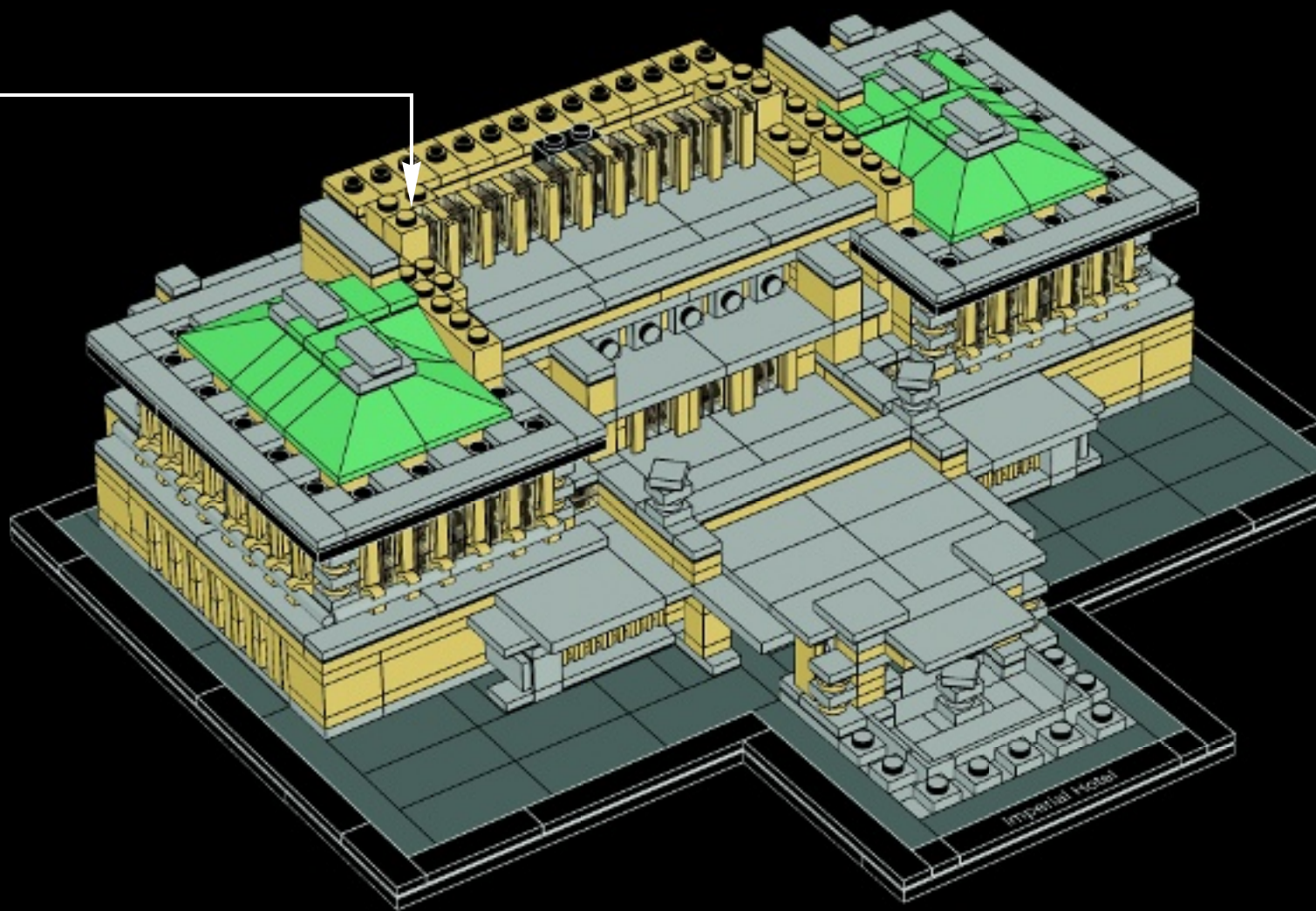



99

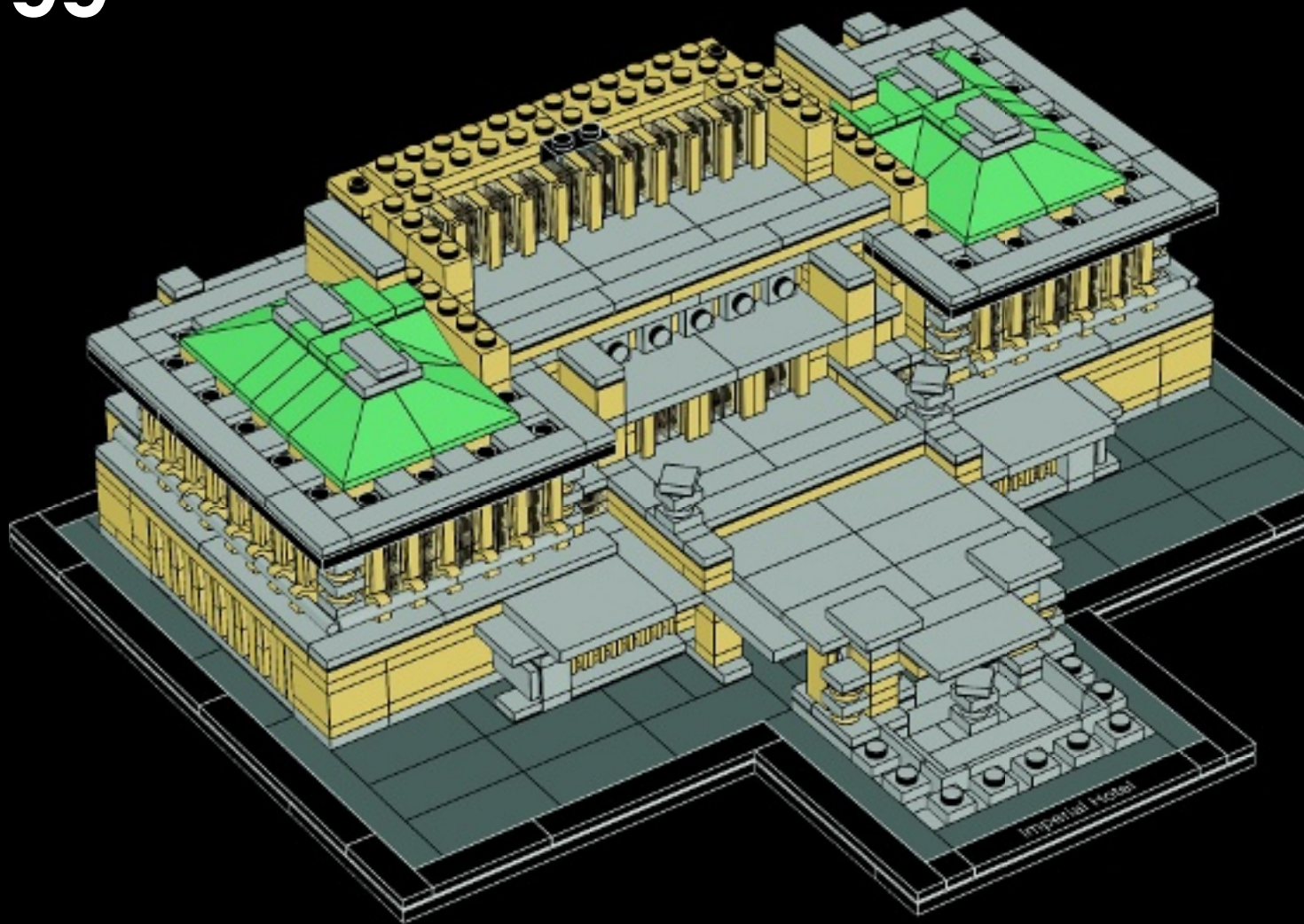



100

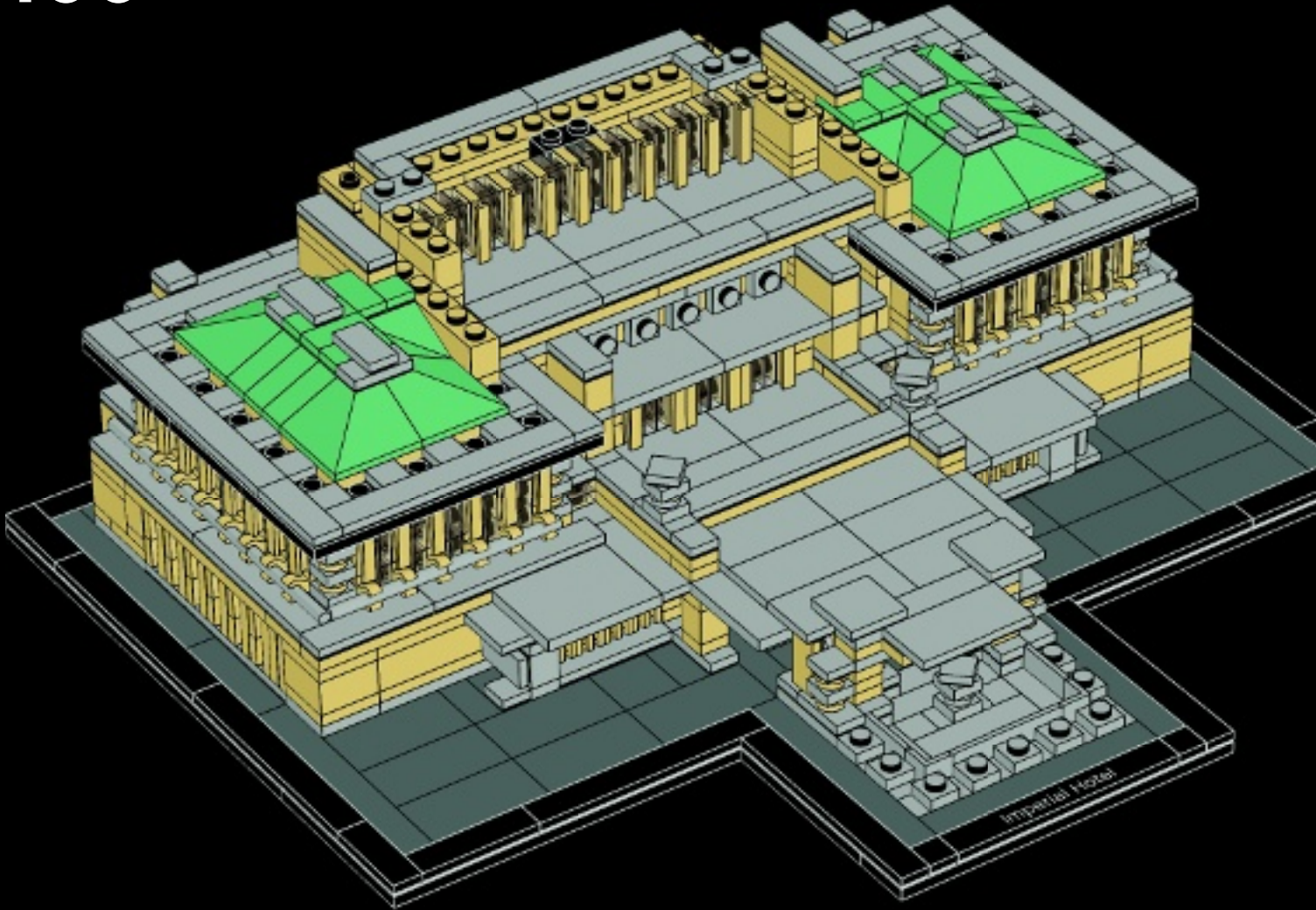

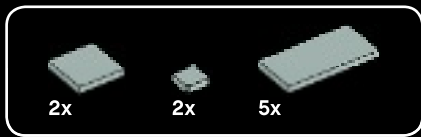

101

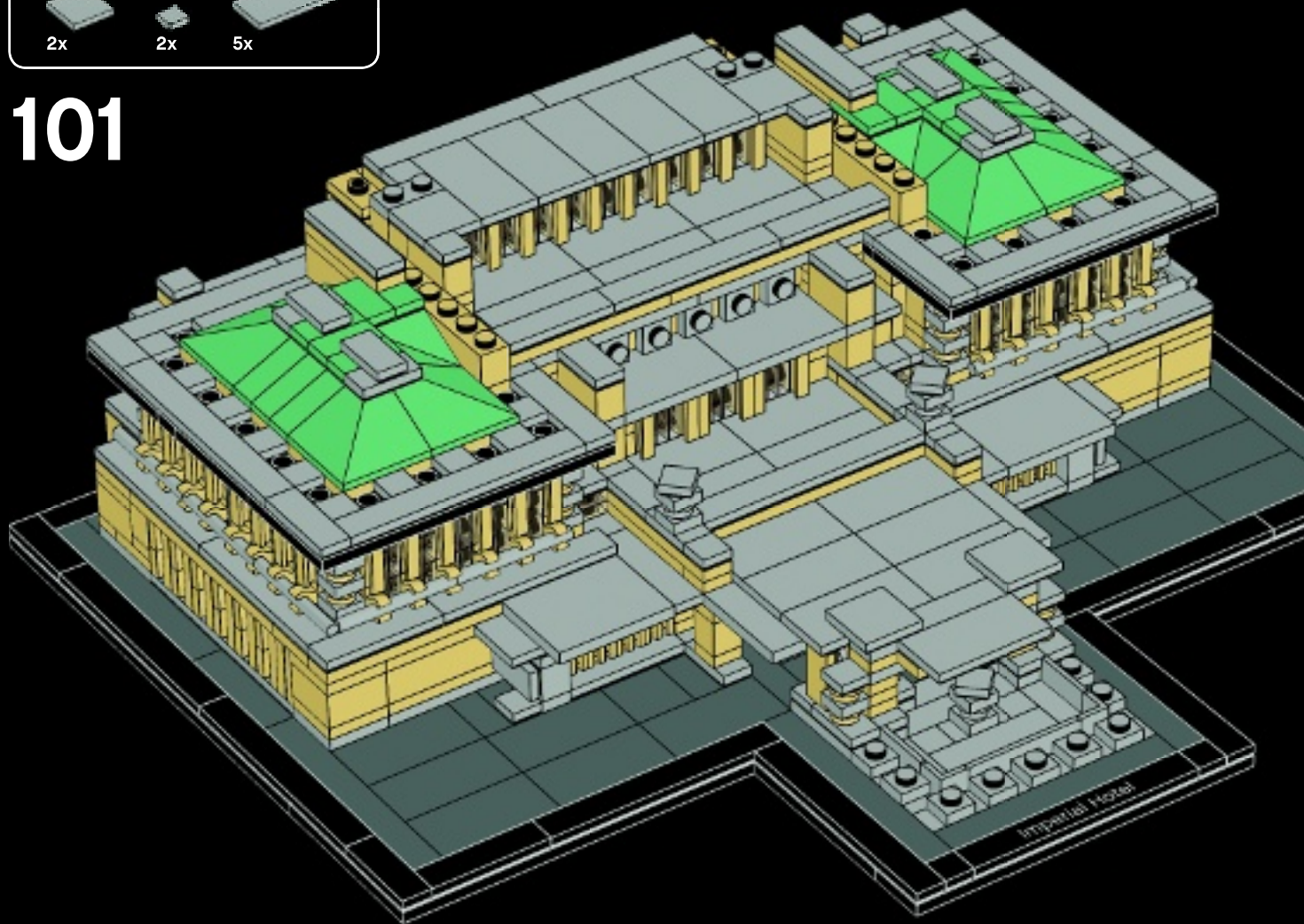

Approx. 600 craftsmen were employed continuously for four of the seven years of the construction process.

Environ 600 artisans furent employés en continu pendant quatre des sept années du processus de construction.



Courtesy of the Frank Lloyd Wright Foundation
Avec l'aimable autorisation de la Frank Lloyd Wright Foundation

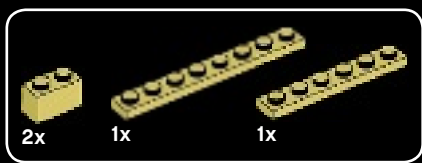

102

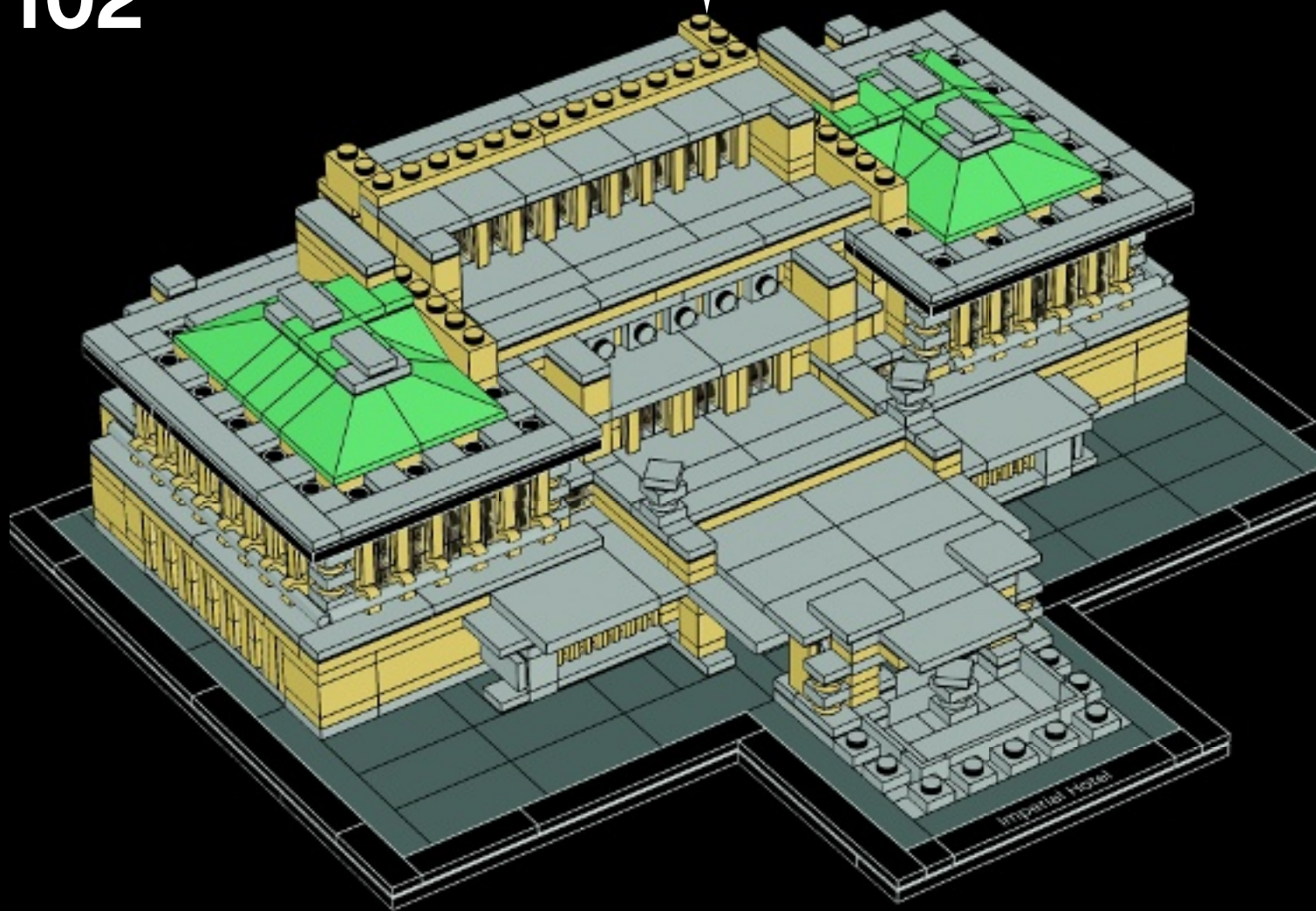



103

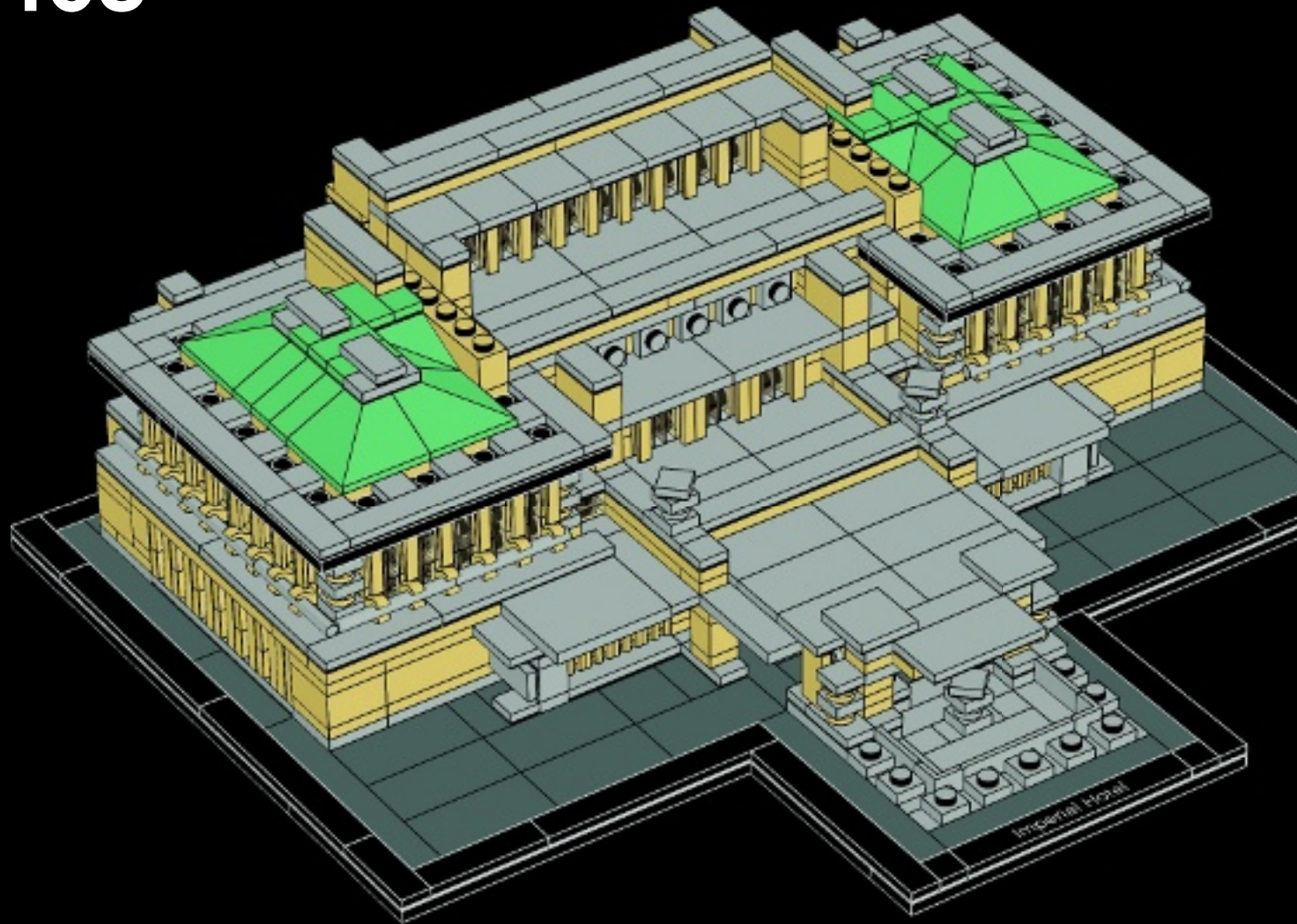

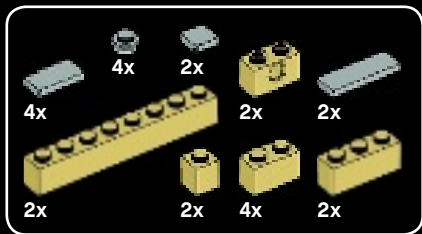

104

1

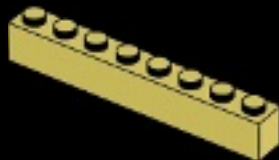

2

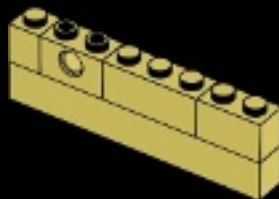

3

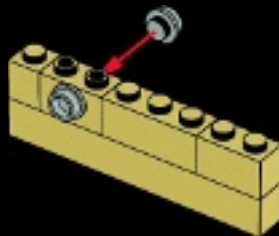

4

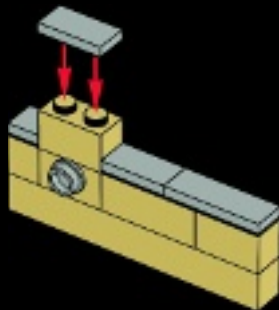

2x

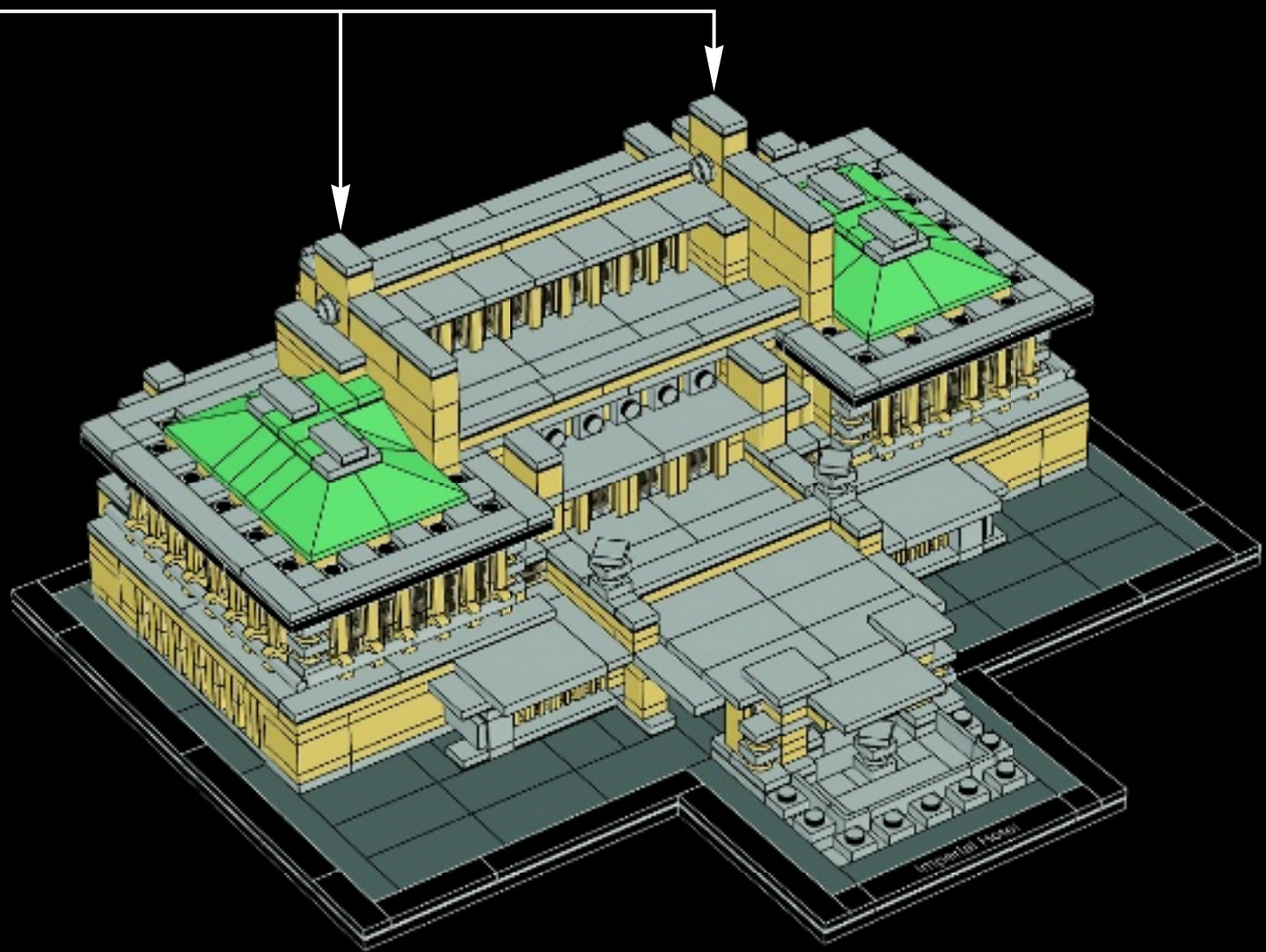

A Word from the Artist

“As a LEGO architect, I set myself a triple challenge while designing this model: to faithfully capture Frank Lloyd Wright’s genius, to respect and accent the Japanese nature of the building and to create an intriguing model, that would be placed alongside existing Frank Lloyd Wright’s sets in the LEGO Architect series.

The task began with choosing what to actually represent in LEGO; the whole of the hotel, or only the entrance lobby that was dismantled and reassembled at the Meiji-mura open-air architectural museum. This part of the building showed great potential for fulfilling my aspirations.

This entrance lobby is (relatively) small-scaled but richly decorated; so the next challenge was how to translate as many of the architectural elements of the original as possible, while keeping the overall size of the LEGO model small. The starting point became the demanding cross section with many different levels, coupled together with the side-wing elevation with its windows.

At the end, the harmonious whole of the model was achieved with a variety of LEGO techniques, including offsetting, sideways construction and SNOT (Studs Not On Top) techniques, as well as the use of LEGO holder plates together with light saber blades as the horizontal accent. “

The Imperial Hotel model was created in close collaboration with the LEGO design team. They look at the model from a LEGO building point of view and ensure the construction process is simple and logical, and a positive experience for the user.

Un mot de l'artiste

« En tant qu'architecte LEGO, je me suis fixé un triple défi en concevant ce modèle : de capturer fidèlement le génie de Frank Lloyd Wright, de respecter et d'accentuer le caractère japonais du bâtiment et de créer un modèle intrigant qui serait placé à côté des autres ensembles Frank Lloyd Wright dans la série LEGO Architecte.

J'ai commencé par choisir que représenter dans le modèle LEGO ; tout le bâtiment, ou seulement le hall d'entrée qui a été démonté et remonté au musée d'architecture en plein air de Meiji-Mura. Cette partie du bâtiment montrait un excellent potentiel pour répondre à mes attentes.

Ce hall d'entrée est (relativement) petit mais richement décoré, le défi suivant était donc de réussir à traduire autant d'éléments architecturaux que possible, tout en

créant un modèle LEGO d'une taille réduite dans son ensemble. Le point de départ est devenu la section transversale complexe, avec de nombreux niveaux, ainsi que l'élévation latérale avec ses fenêtres.

L'ensemble harmonieux du modèle fut finalement obtenu avec diverses techniques LEGO, notamment des constructions latérales décalées et des techniques SNOT (tenons pas sur le dessus) ainsi que l'utilisation de plaques LEGO avec des sabres laser comme accent horizontal ».

Le modèle de l'Hôtel Imperial fut créé en collaboration étroite avec l'équipe de design LEGO. Elle regarde le modèle du point de vue de la construction LEGO pour s'assurer que le processus de construction est simple et logique, et constitue une expérience positive pour l'utilisateur.

Rob Kober



The 'Scale Model' line – LEGO Architecture in the 1960s

The history of the current LEGO Architecture series can be traced back to the beginning of the 1960s when the LEGO brick's popularity was still steadily increasing. Godtfred Kirk Christiansen, the then owner of the company, began looking for ways to further expand the LEGO system, and asked his designers to come up with a set of new components that would add a new dimension to LEGO building.

Their answer was as simple as it was revolutionary: five elements that matched the existing bricks, but were only one third the height. These new building 'plates' made it possible to construct more detailed models than before.

This greater LEGO flexibility seemed to match the spirit of the age; where modernist architects were redefining how houses looked, and people were taking an active interest in the design of their dream home. It was from these trends that the LEGO 'Scale Model' line was born in early 1962.

The name itself was a direct link to the way architects and engineers worked and it was hoped that they and

others would build their projects 'to scale' in LEGO elements. As with LEGO Architecture today, the original sets were designed to be different from the normal brightly coloured LEGO boxes, and also included 'An Architectural Book' for inspiration.

Though the five elements remain an integral part of the LEGO building system today, the 'Scale Model' line phased out in 1965 – it would be over 40 years before its principles would be revived in the LEGO Architecture series we know today.

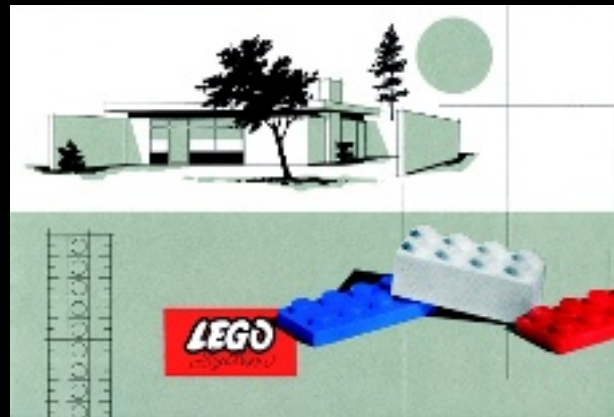

La collection « Modèle à l'échelle » : LEGO Architecture dans les années 1960

L'histoire de la série LEGO Architecture actuelle remonte au début des années 1960, lorsque la popularité de la brique LEGO augmentait de façon stable. Godtfred Kirk Christiansen, le propriétaire de l'entreprise à l'époque, commença à chercher des façons d'étendre le système LEGO et demanda à ses designers de créer un ensemble de composants qui ajouteraient une nouvelle dimension à la construction LEGO.

Leur réponse fut aussi simple que révolutionnaire : cinq éléments qui s'assemblaient avec les briques existantes, mais trois fois moins hautes qu'elles. Ces nouvelles « plaques » de construction permirent de construire des modèles plus détaillés que par le passé.

Cette plus grande flexibilité LEGO semblait correspondre à l'esprit de l'époque : les architectes modernistes redéfinissaient l'esthétique des maisons, et les gens participaient activement à la conception de la maison de leurs rêves. C'est de ces tendances qu'est née la collection « Modèle à l'échelle » au début de l'année 1962.

Le nom lui-même était un lien direct avec la façon dont les architectes et les ingénieurs travaillaient, en espérant que ces derniers et d'autres allaient construire leurs projets « à l'échelle » avec des éléments LEGO. Comme avec LEGO Architecture aujourd'hui, les ensembles originaux étaient construits de façon à être différents des boîtes LEGO normales aux couleurs vives, et incluaient aussi « Un livre d'architecture » comme source d'inspiration.

Les cinq éléments font toujours partie du système de construction LEGO actuel, mais la collection « Modèle à l'échelle » fut arrêtée en 1965. De nombreux principes de la série allaient réapparaître plus de 40 ans plus tard dans la série LEGO Architecture que nous connaissons aujourd'hui.

Architect series

Série Architectes

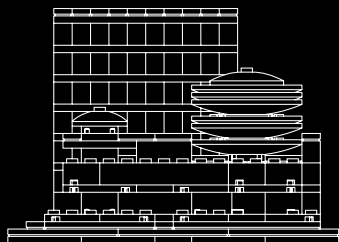

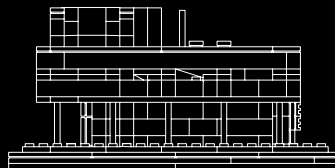
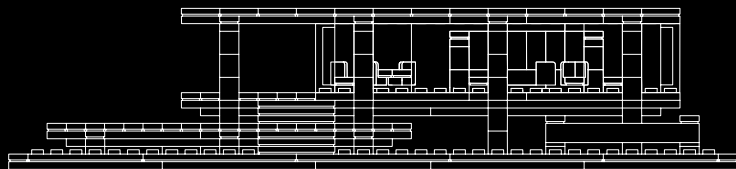
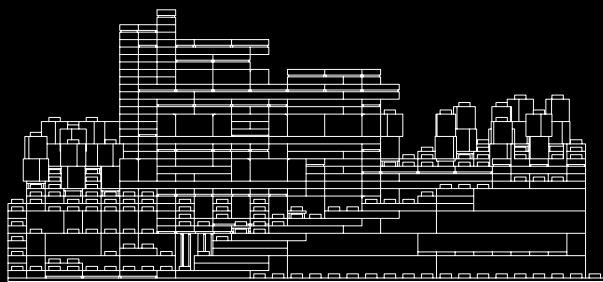

Landmark series

Série Monuments

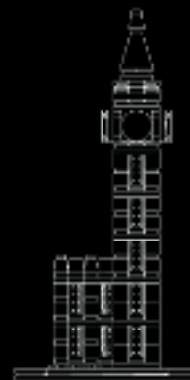
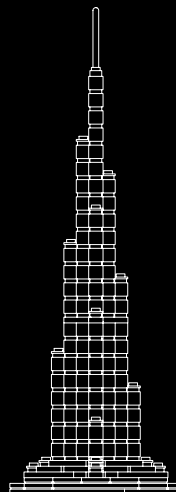
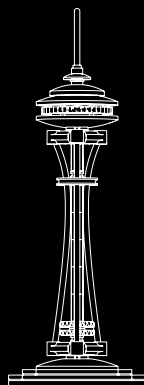
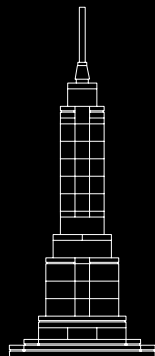
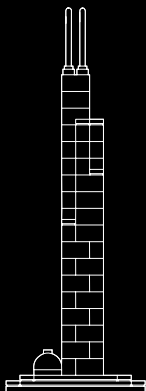

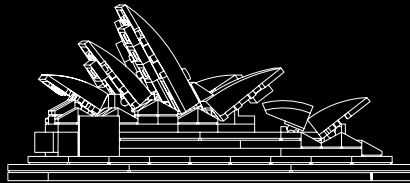
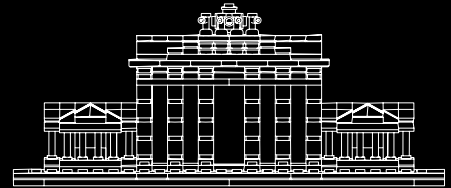
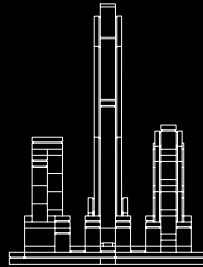
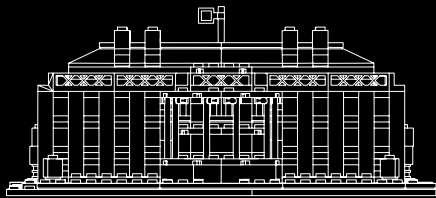



2x
611101



10x
300501



8x
302401



17x
302301



12x
4113915



22x
4109995



6x
4114064



4x
4114306



6x
4124455



6x
4162465



10x
4113916



4x
4114319



6x
4112982



1x
4181134



11x
4159774



1x
4166138



14x
4579260



2x
4213568



2x
4205107



52x
4159553



47x
4155708



16x
4113917



8x
4114077



10x
4114084



6x
4121921



28x
6029889



44x
4160483



20x
4118790



12x
4113233



2x
4114309



12x
4124067



2x
4113993



18x
4114324

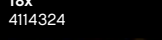

2x
4113988



11x
4143409



1x
4509897



1x
6030980



1x
6030980



8x
4124456



8x
4114026



28x
4161734



10x
300426



2x
362226



2x
300226



2x
307026



1x
306926



4x
4558170



2x
243126

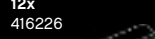

12x
416226

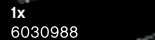

1x
6030988

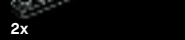

2x
447726



6x
303026



1x
4654448



10x
4598531



2x
6029891



6x
4598532



10x
4616578



2x
301026



2x
4162443



1x
244526



5x
302826



6x
302726



107x
6001197



32x
4529685



40x
6030982



2x
6015344



58x
4211399



16x
4211398



56x
4211451



8x
4211353



10x
4211396



4x
4211445

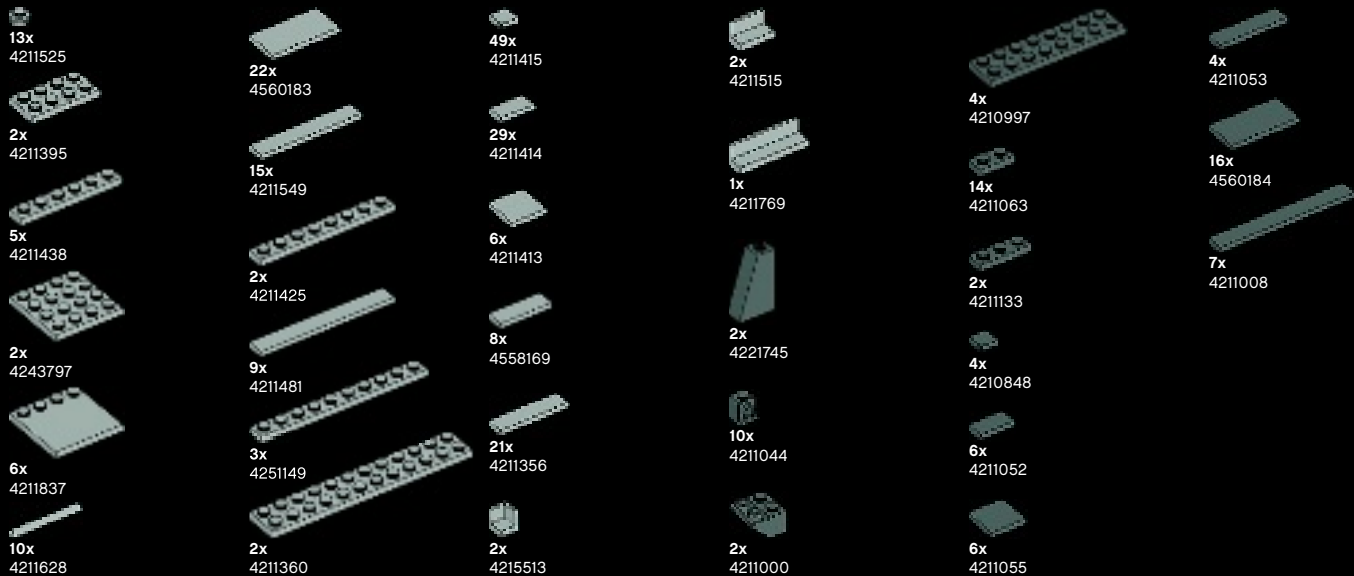

References: Références :

<http://www.franklloydwright.org>

<http://designmuseum.org>

<http://wikipedia.org>

Customer Service
 Kundenservice
 Service Consommateurs
 Servicio Al Consumidor
www.lego.com/service
 or dial
 ou composez



00800 5346 5555 :

1-800-422-5346 :



Architecture



LEGO and the LEGO logo are trademarks of the/
LEGO et le logo LEGO sont des marques de commerce de/
son marcas registradas de LEGO Group. ©2013 The LEGO Group. 6043473