

LEGO

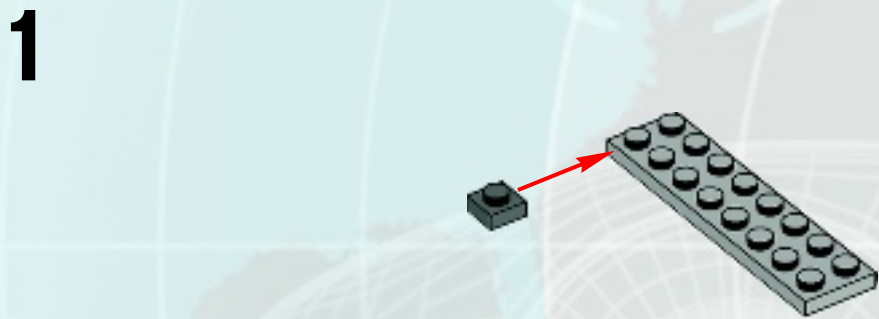

8679

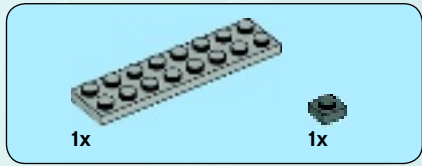

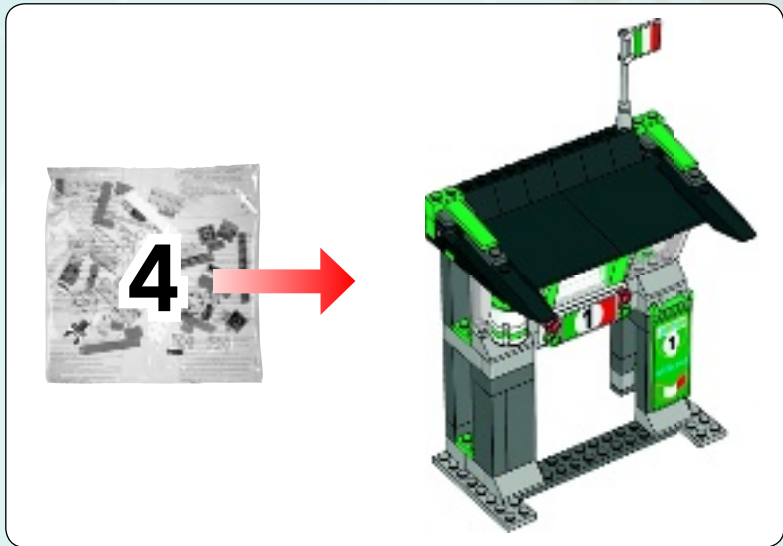

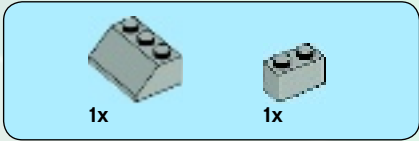

3

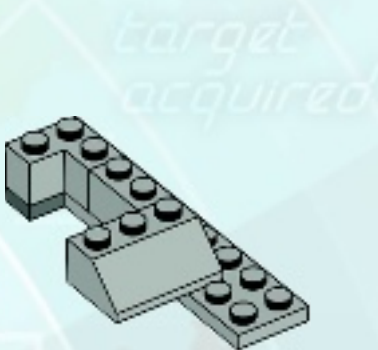

Waypoint 2

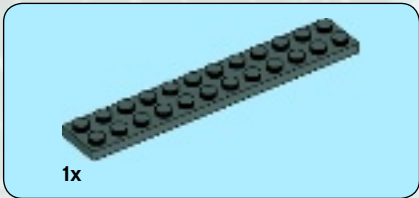

4

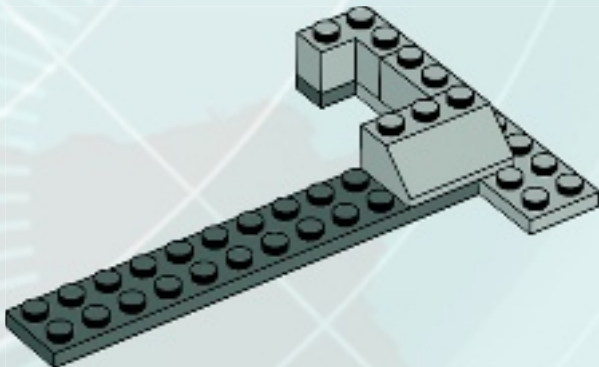

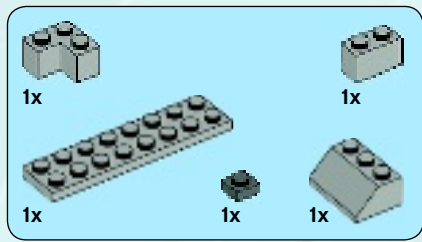

5

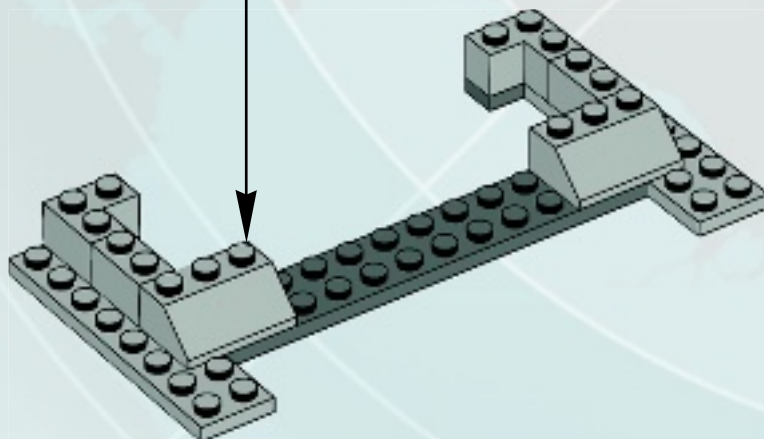
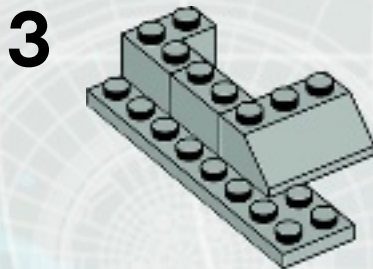
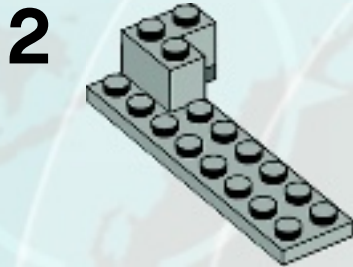
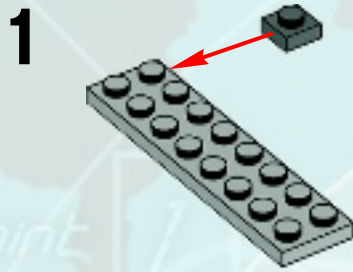



6

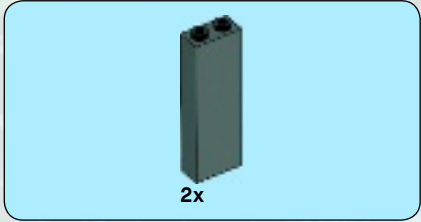
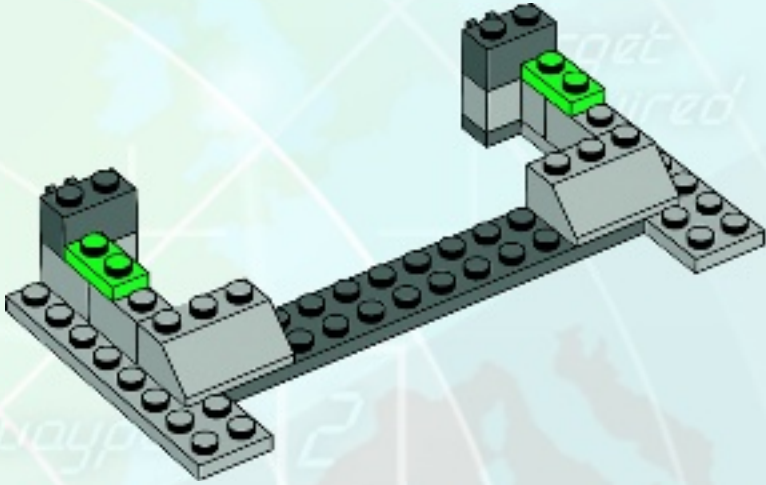

7

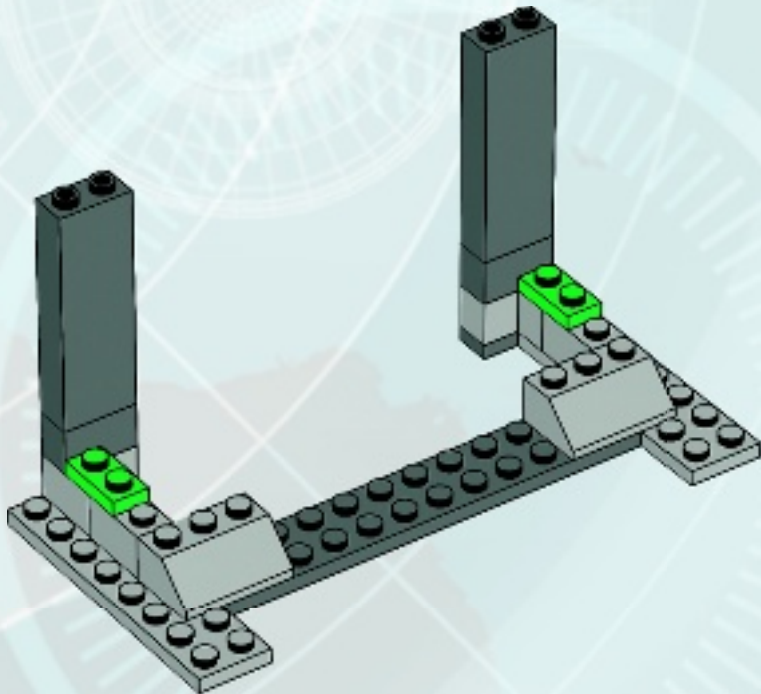

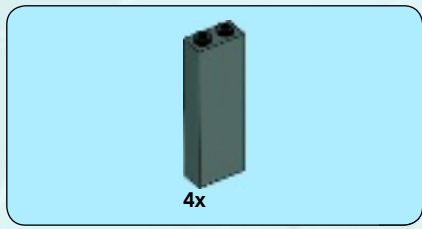

8

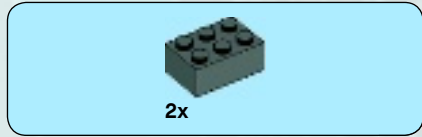
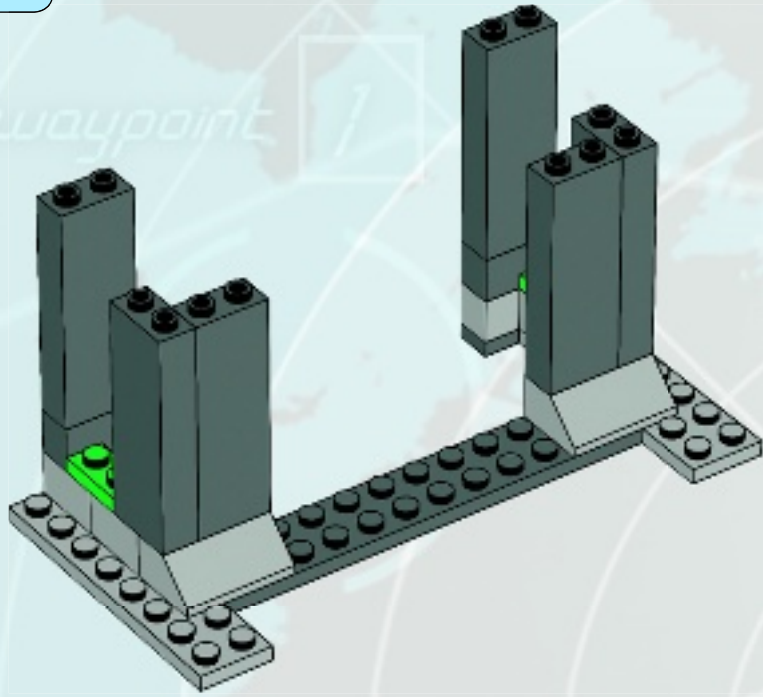

9

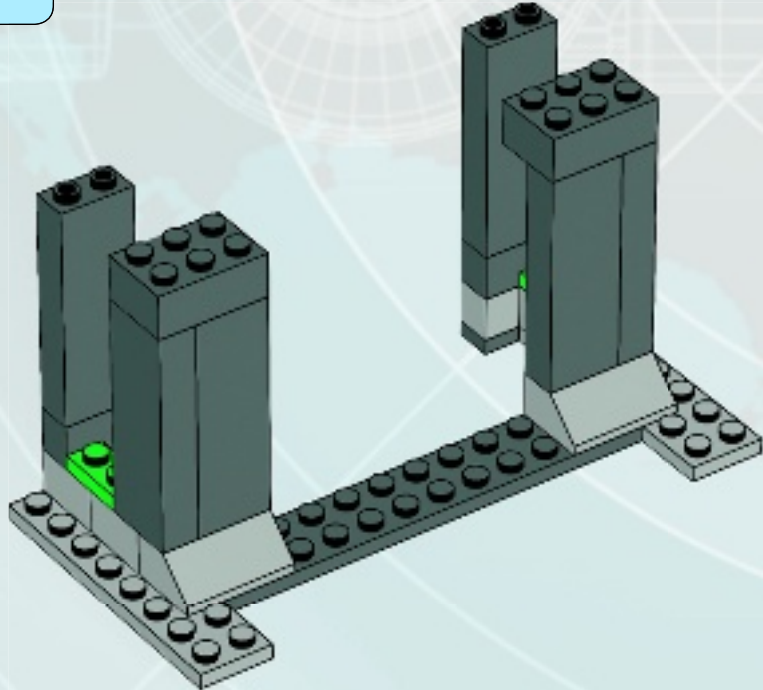

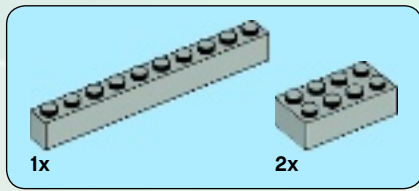

10

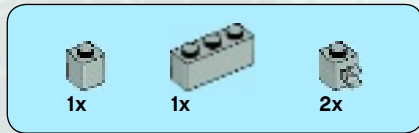
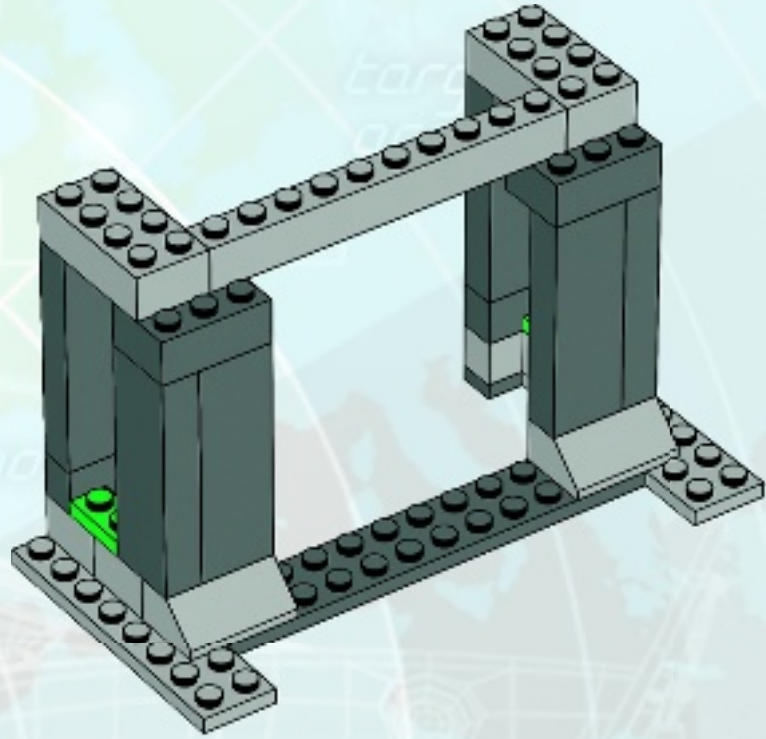

11

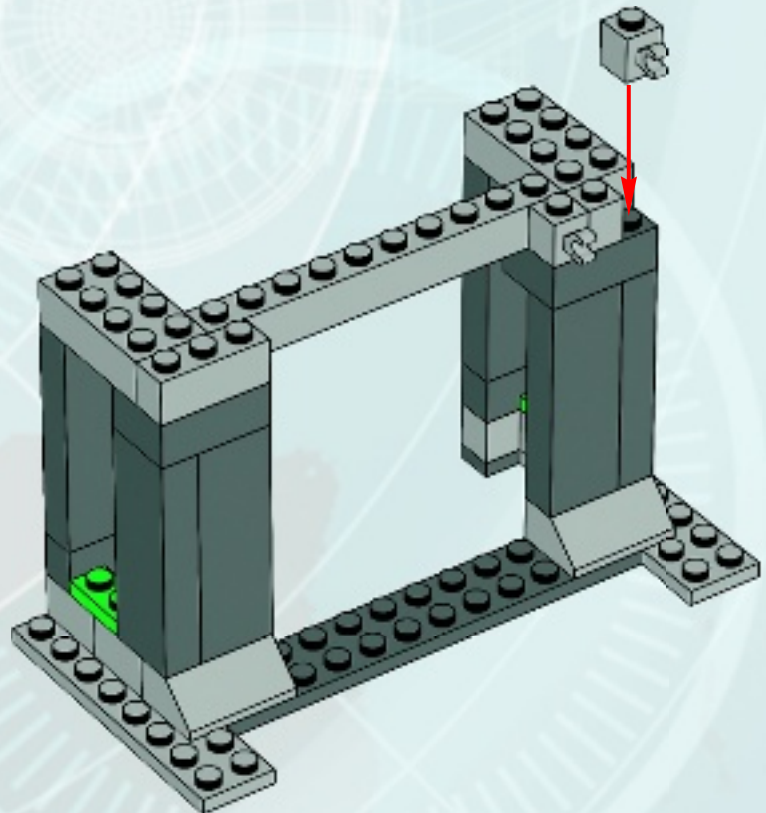

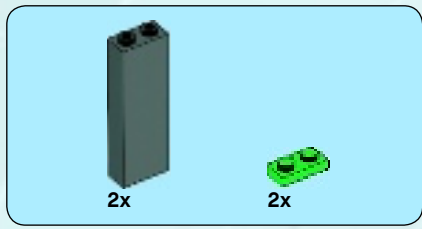

12

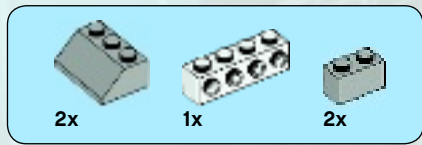
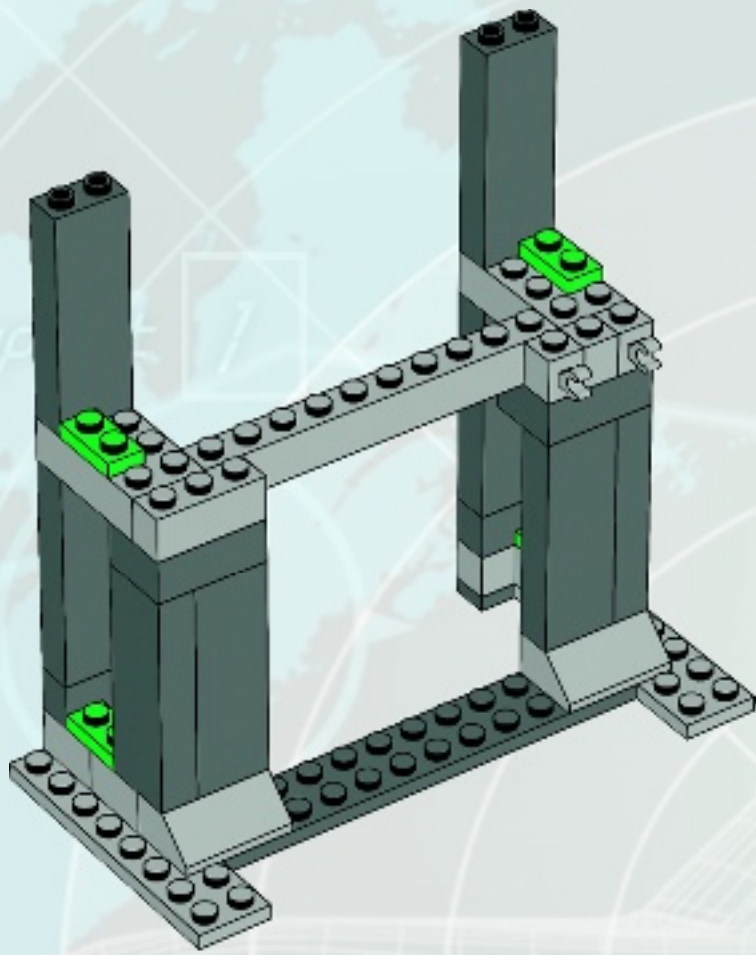

13

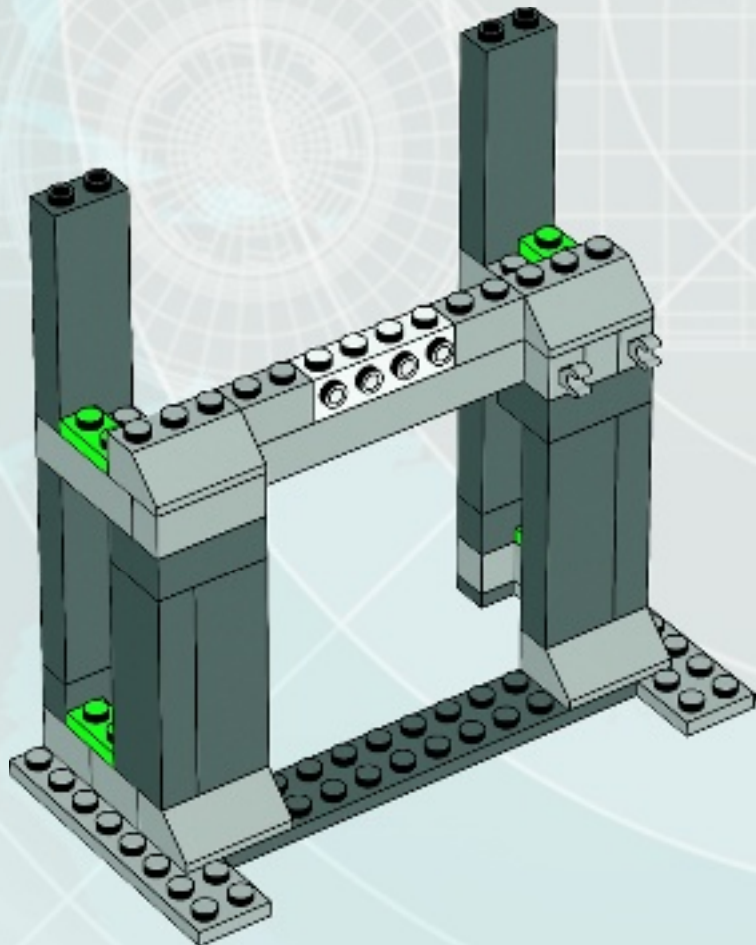



14

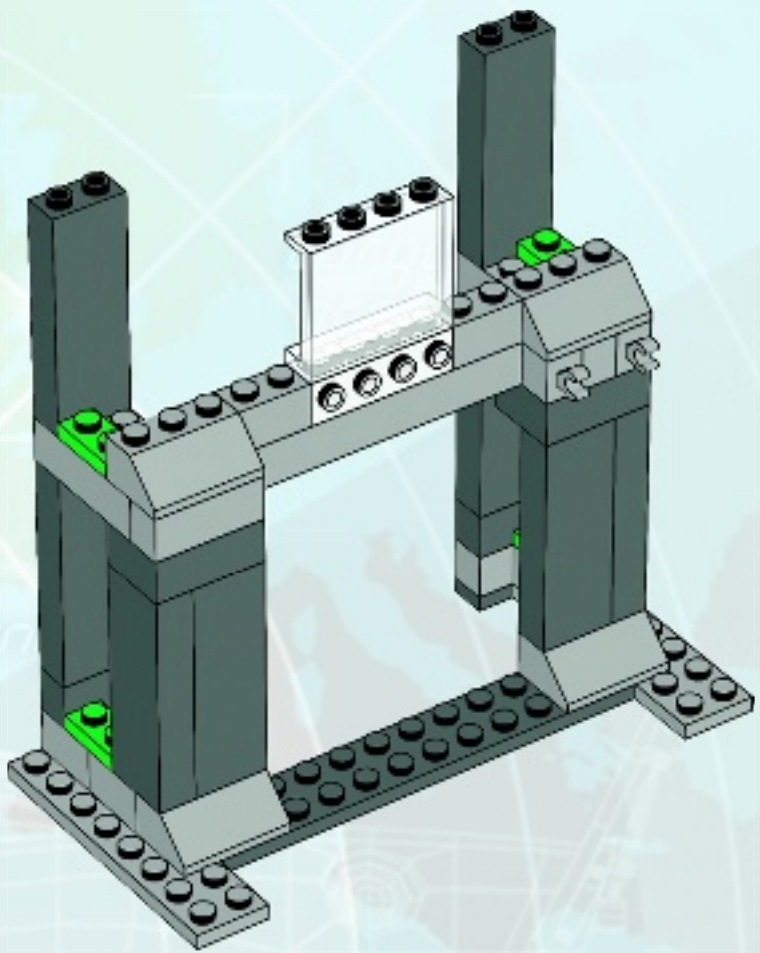

15

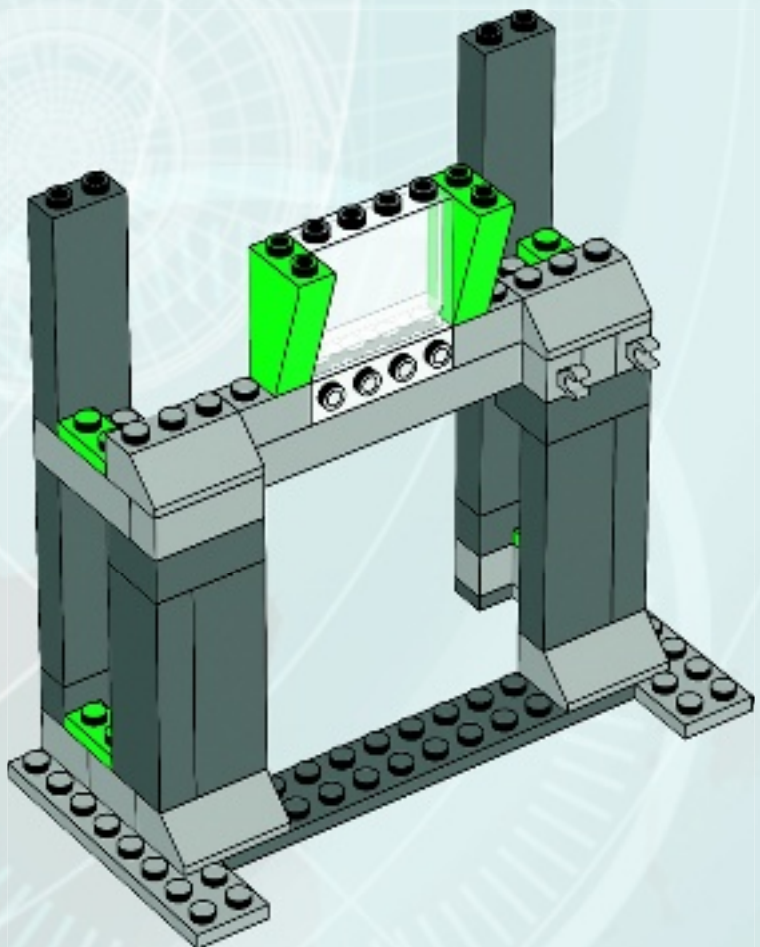

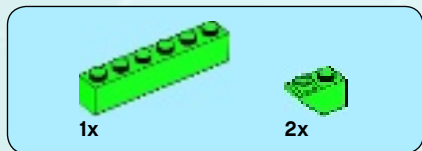

16

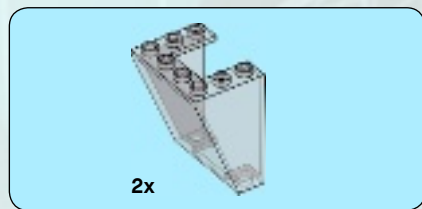
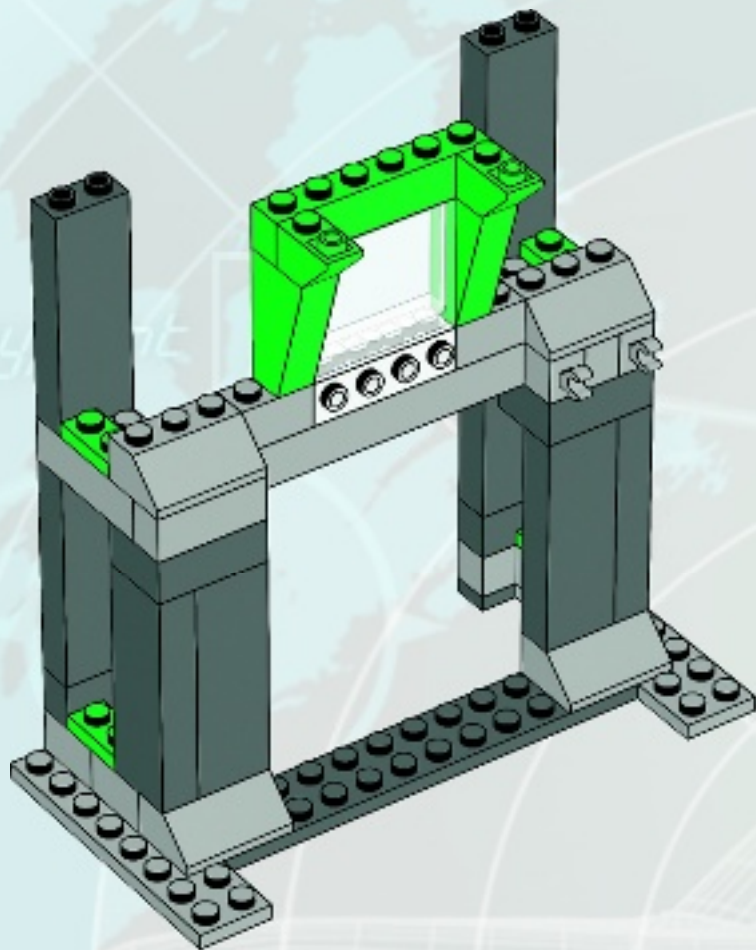

17

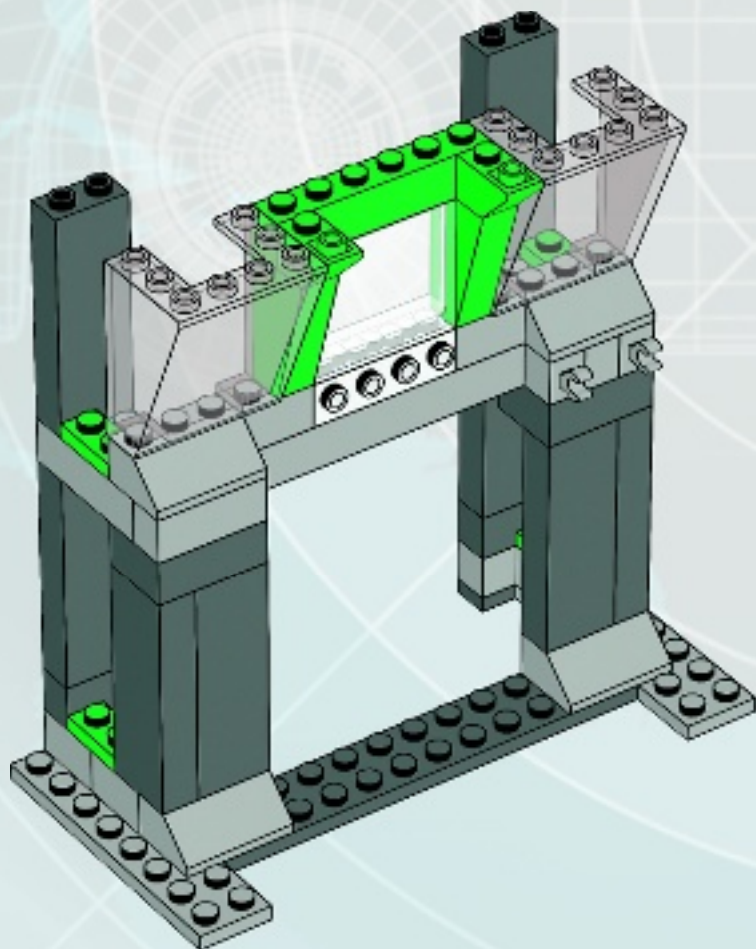



2x

18

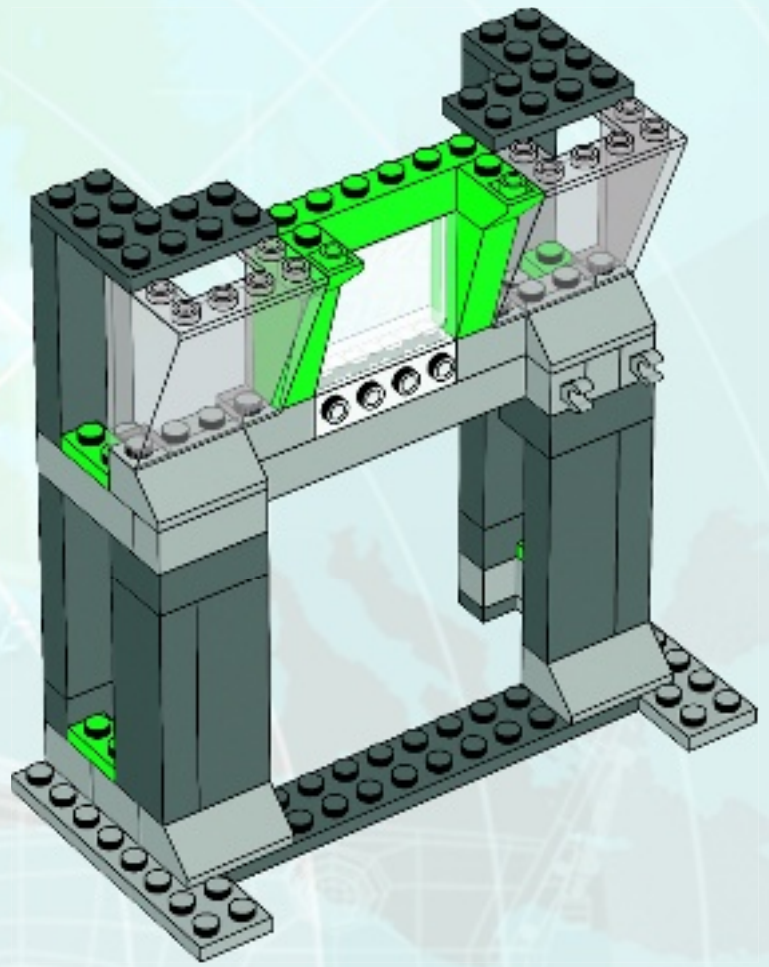

1x



2x

19

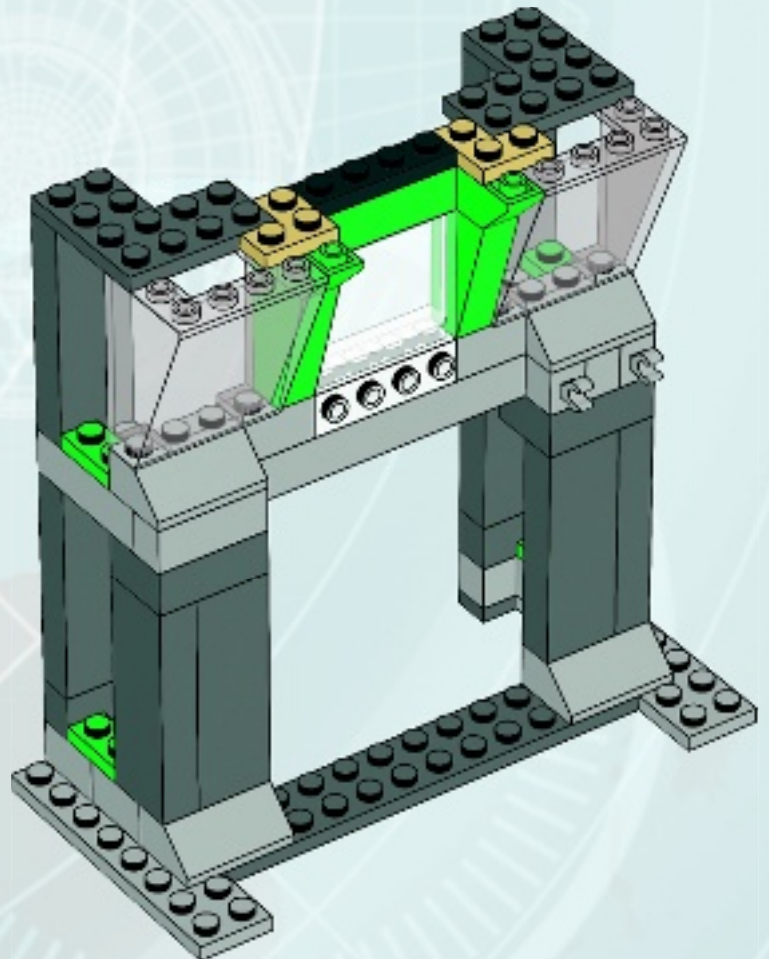



20

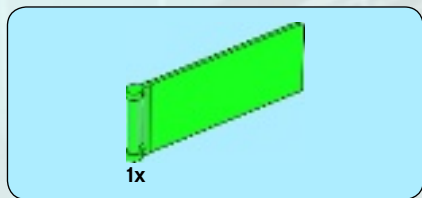
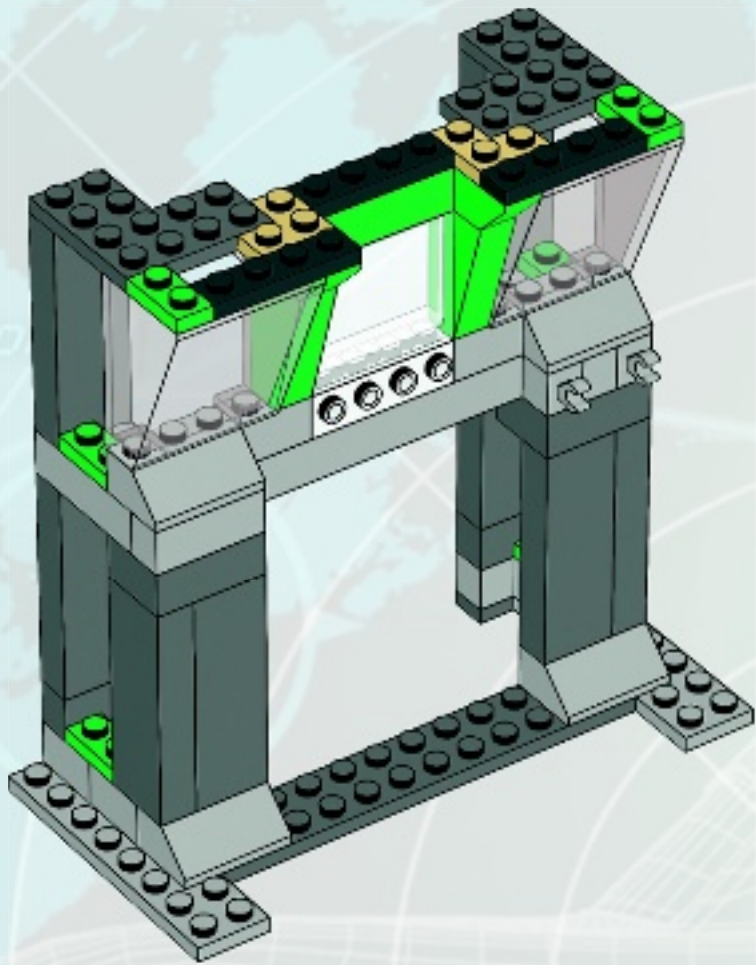

21

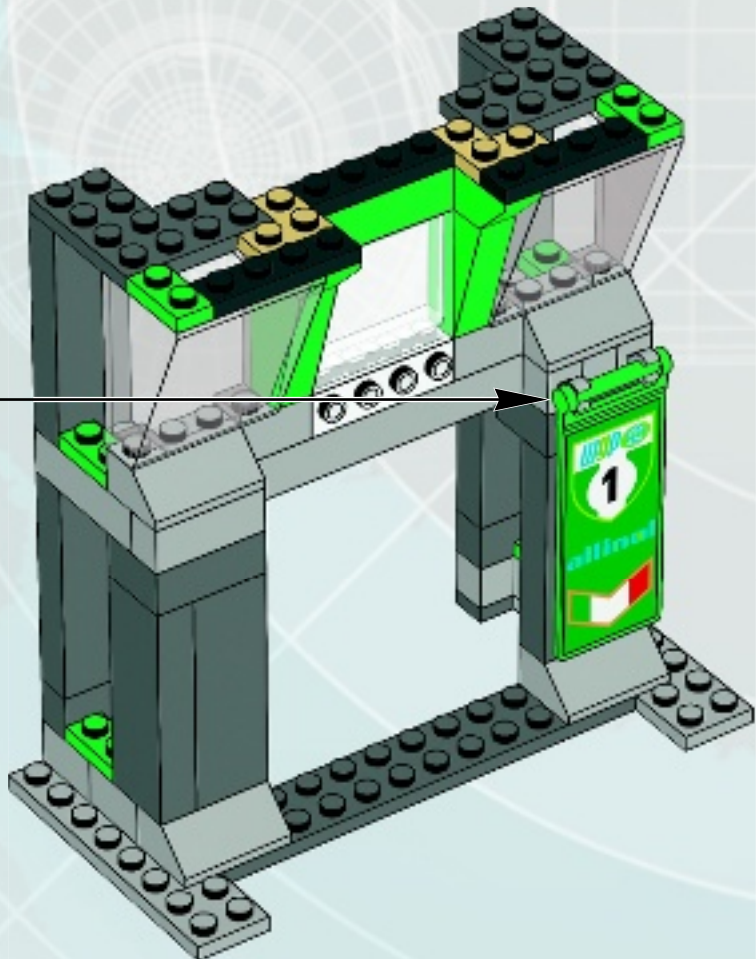
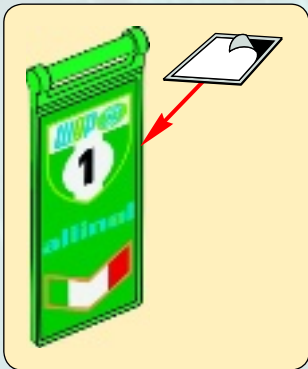

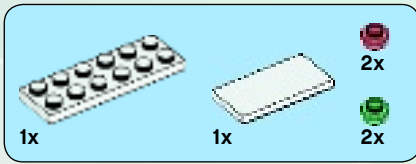

22

target acquired

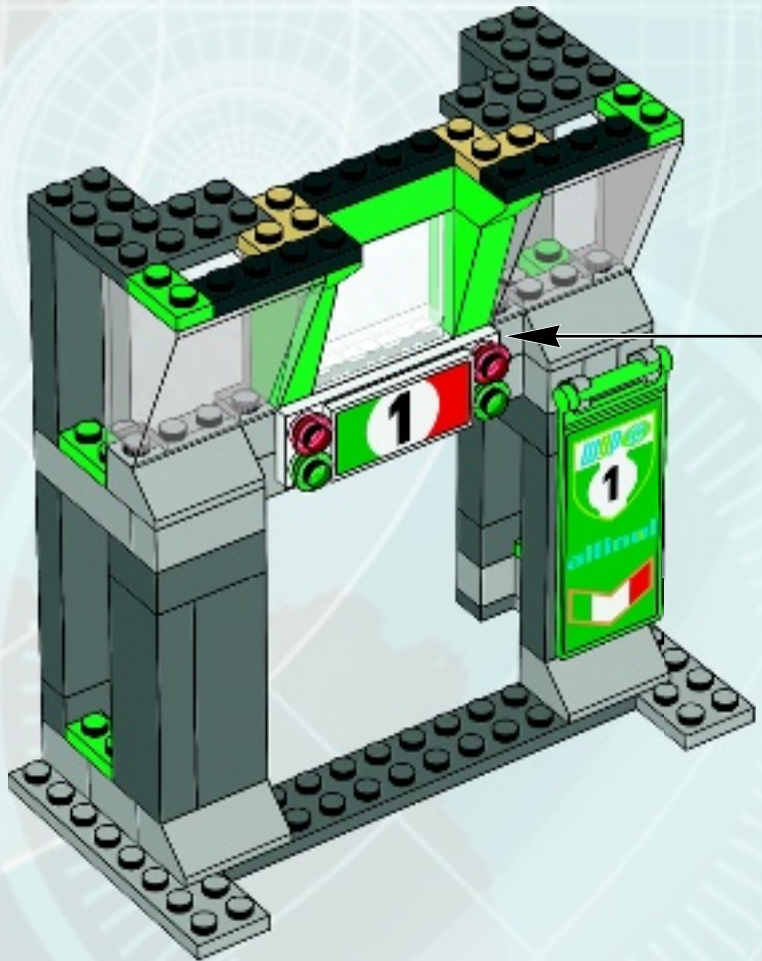
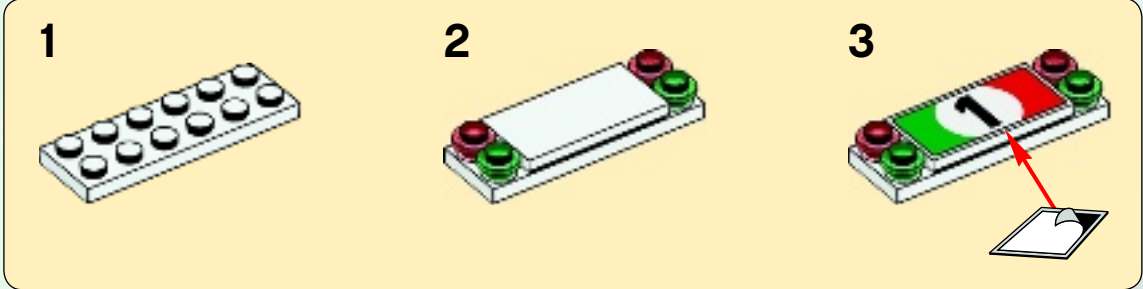

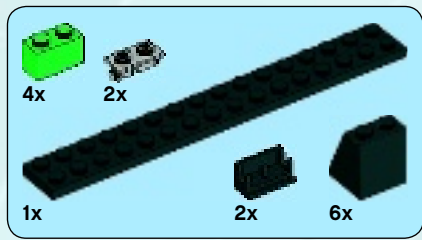

23

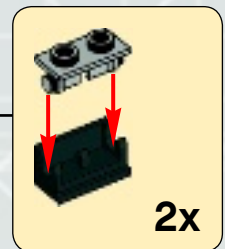
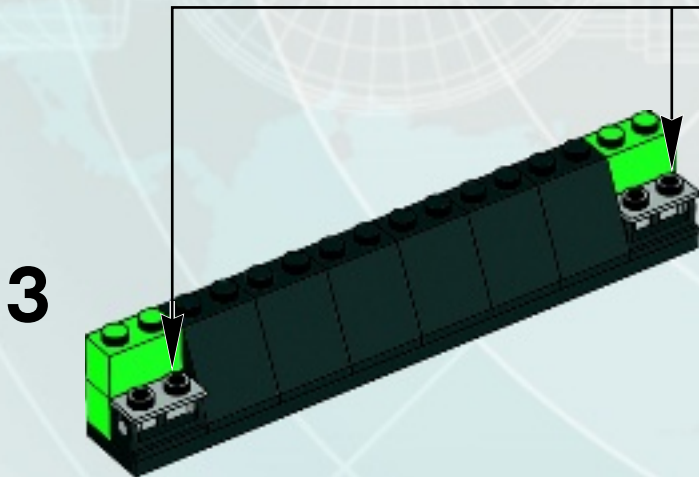
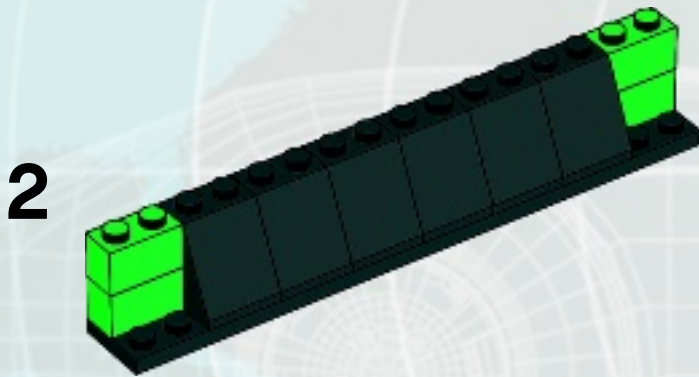

target
acquired

waypoint 2

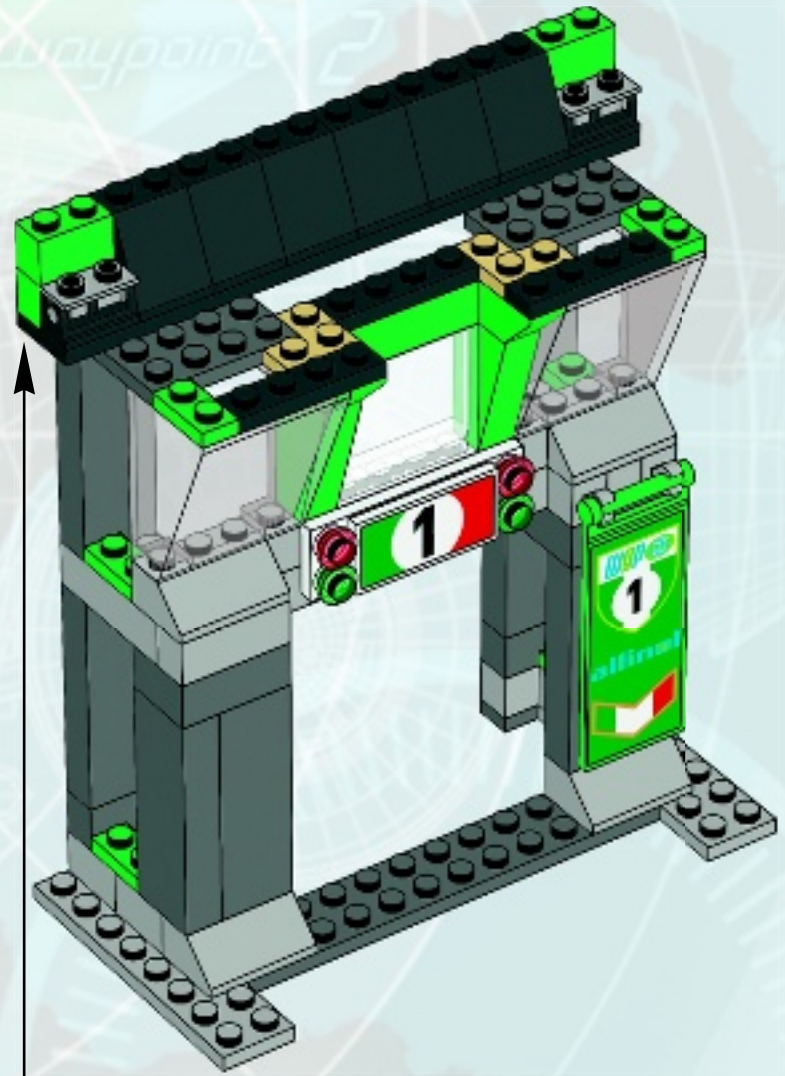

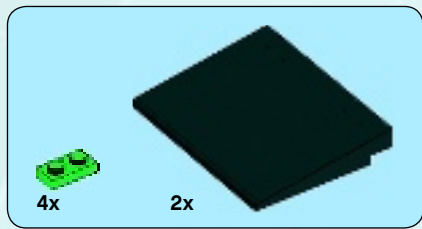

24

waypoint 1

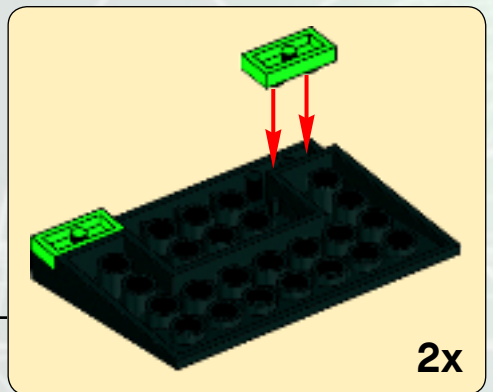
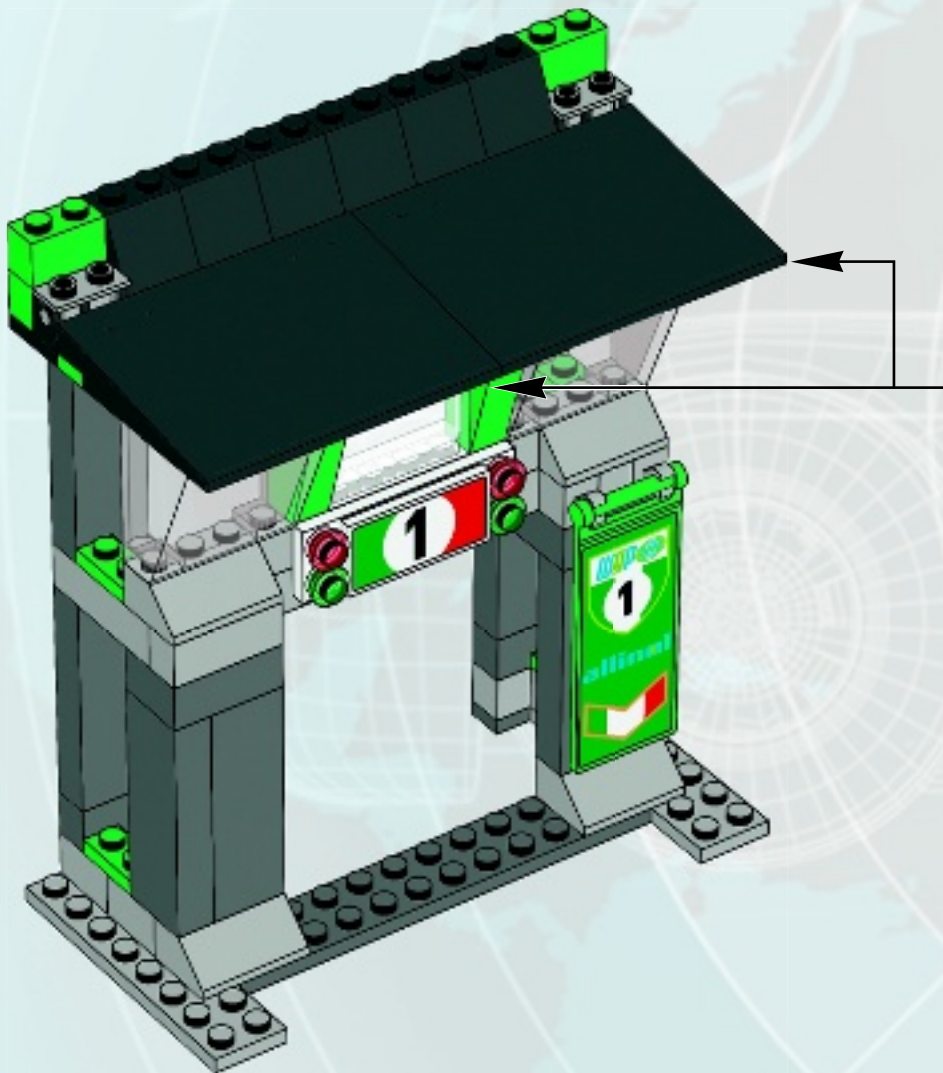

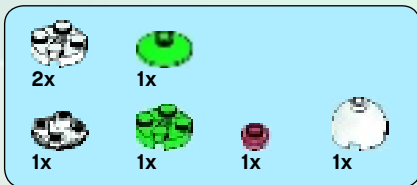

25

*target
acquired*

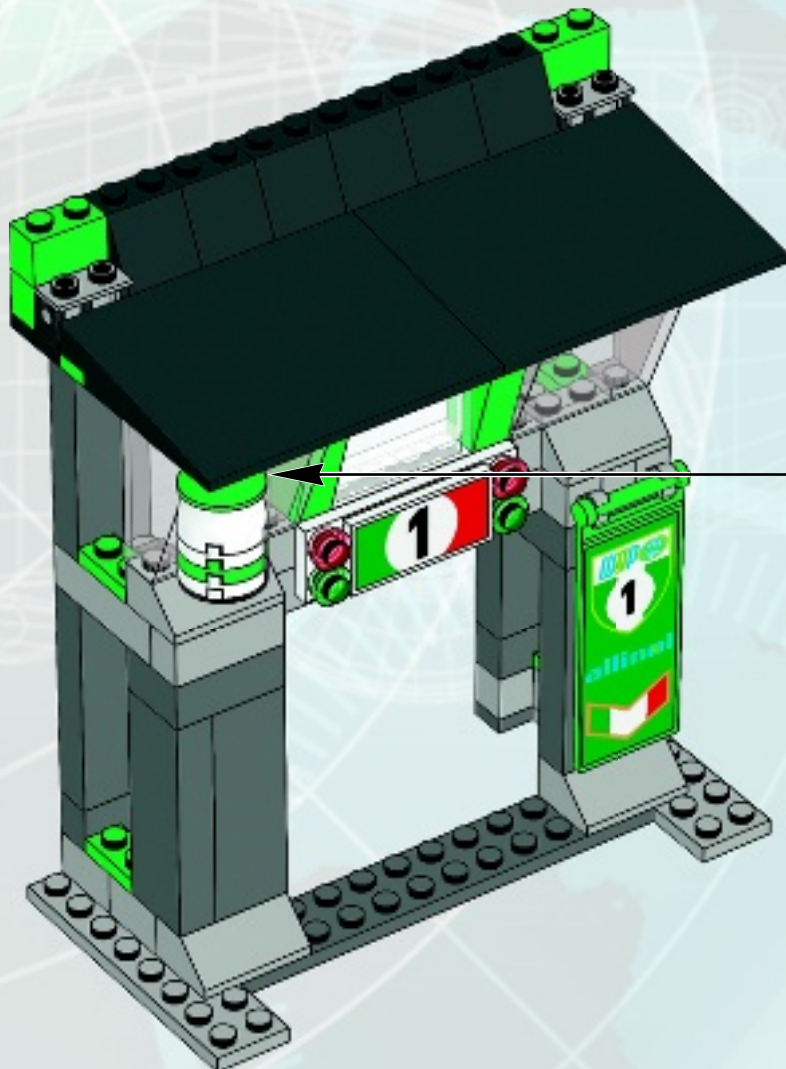
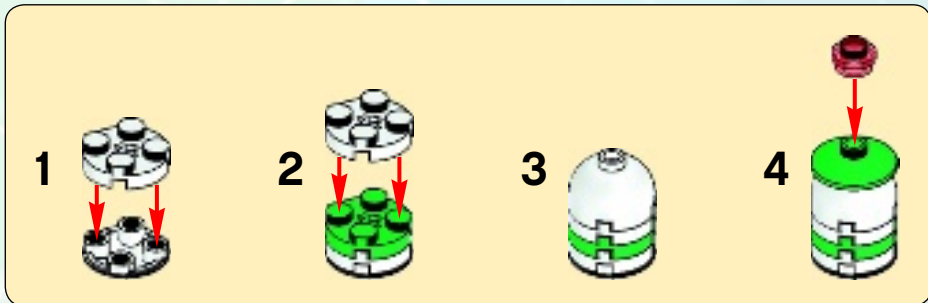

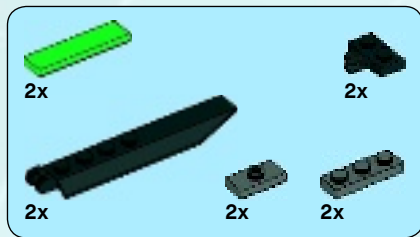

26

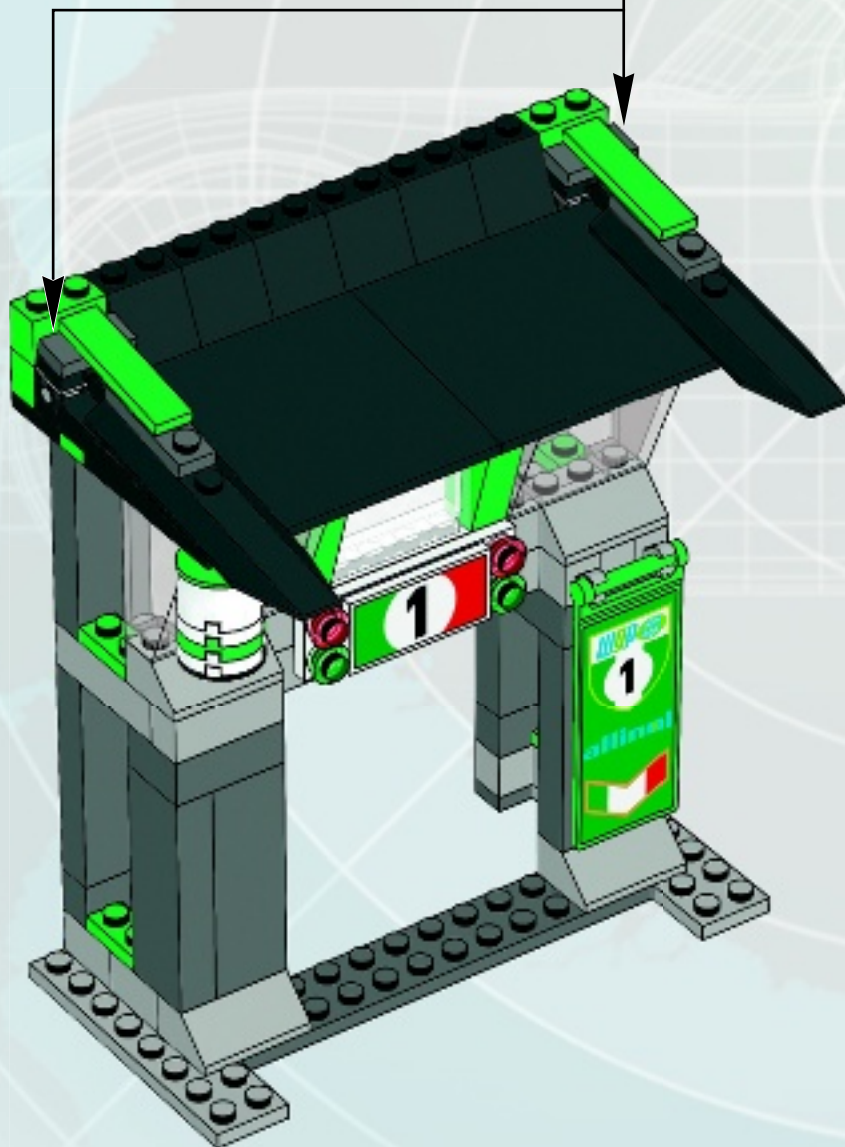
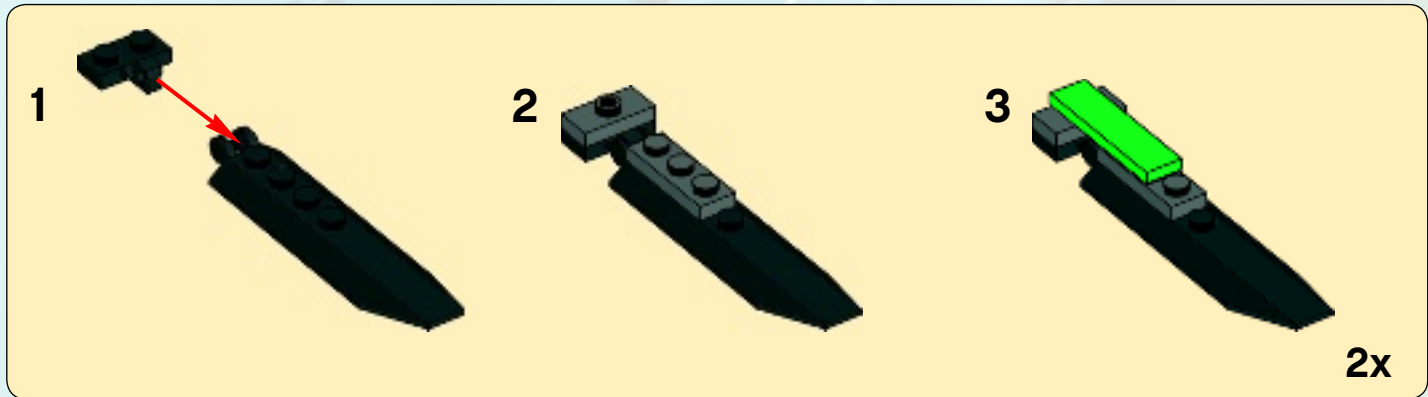

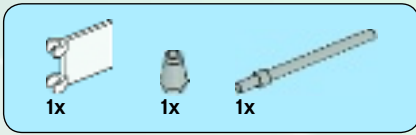

27

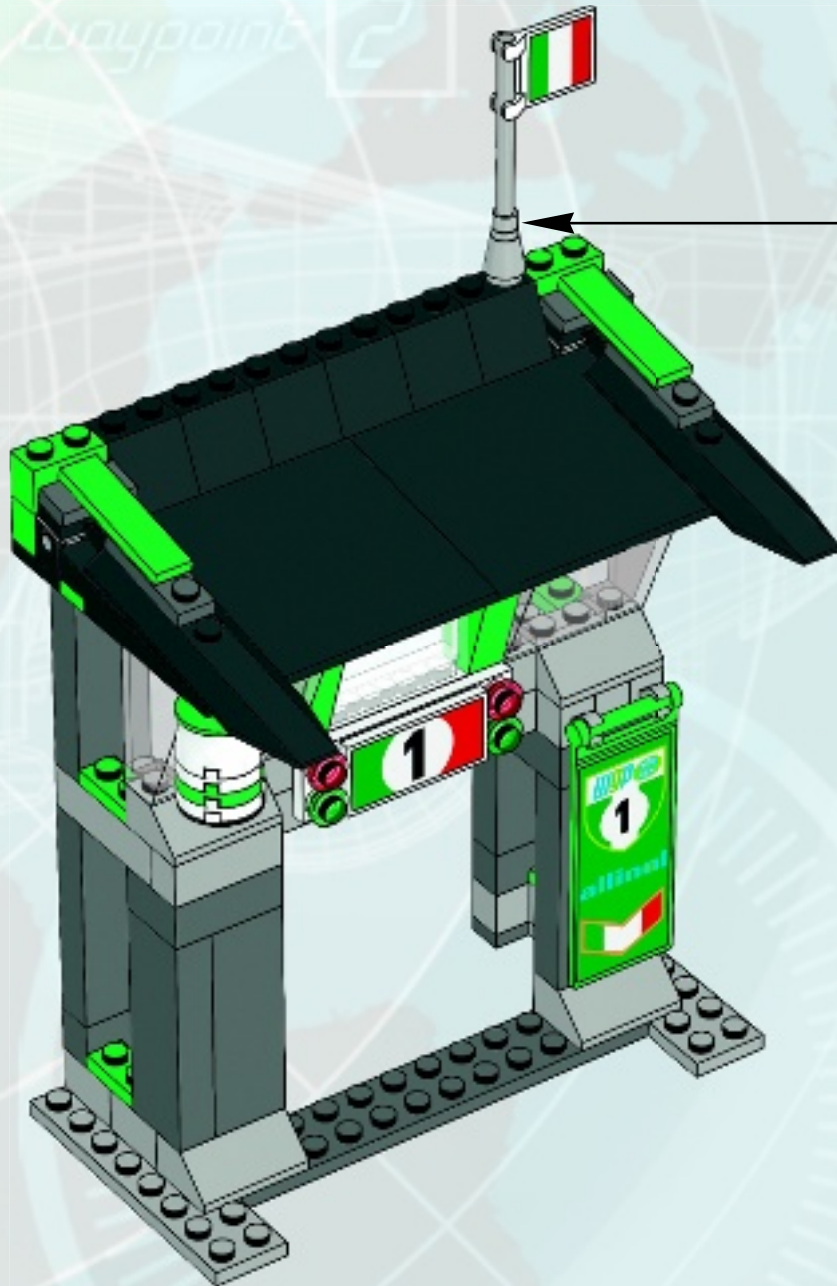
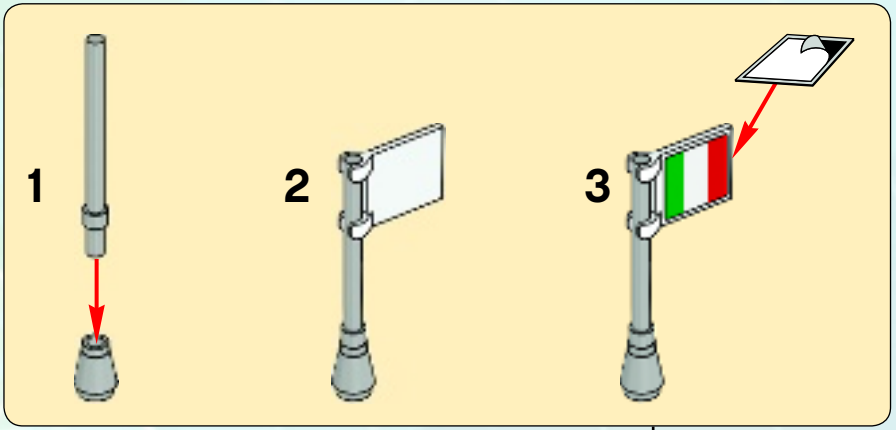

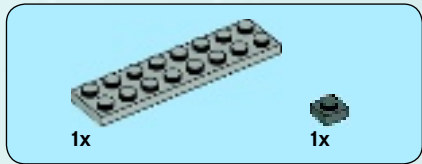
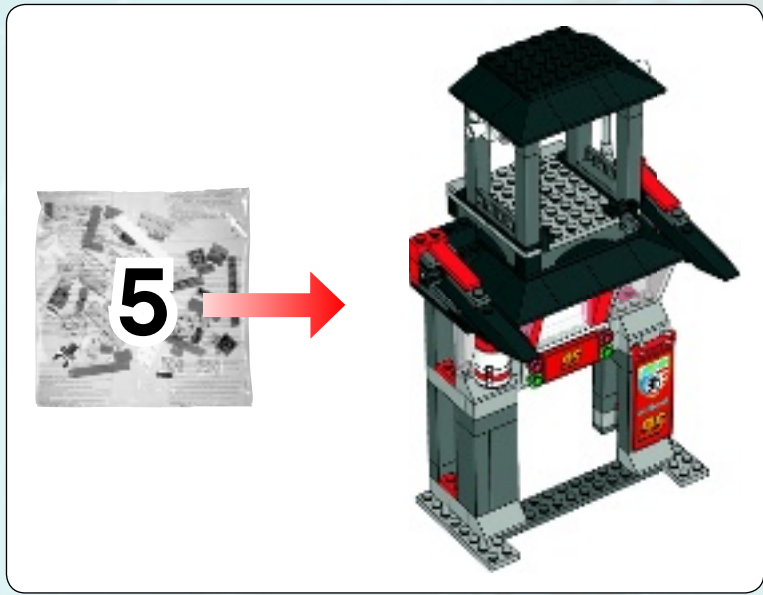

1



2

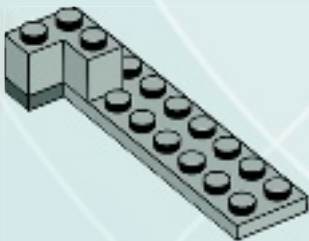

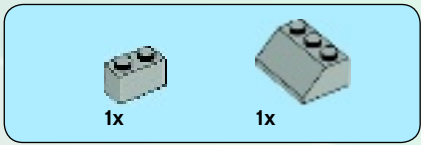

3

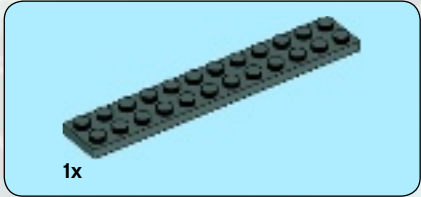
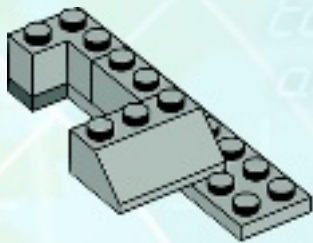

4

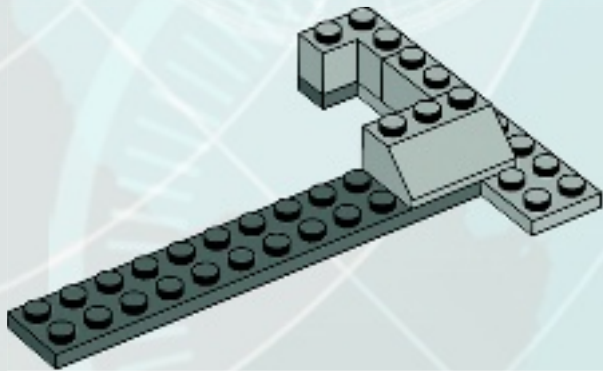

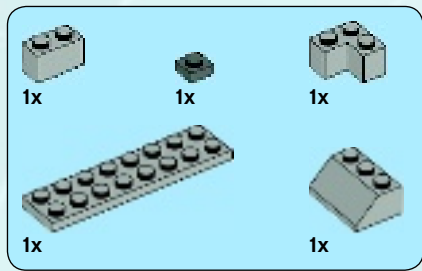

5

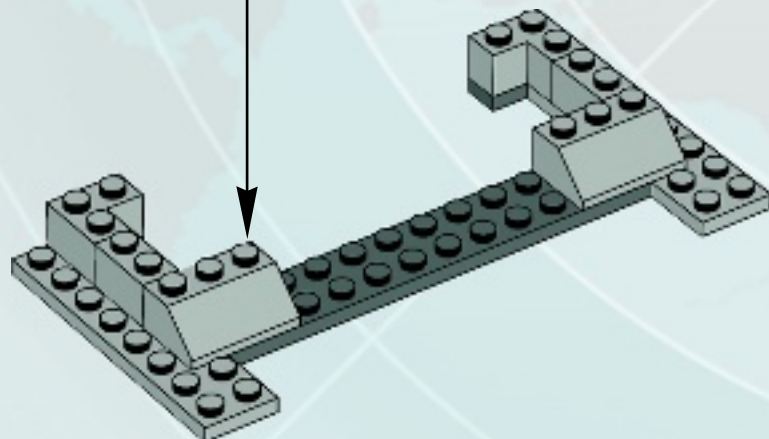
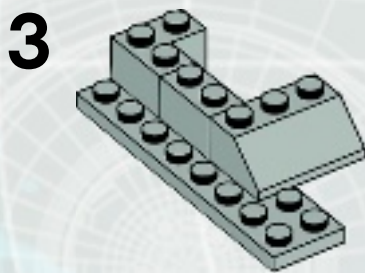
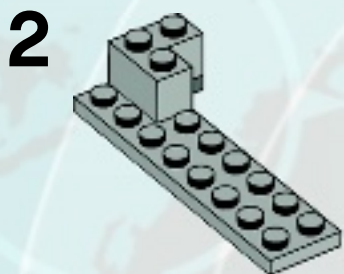
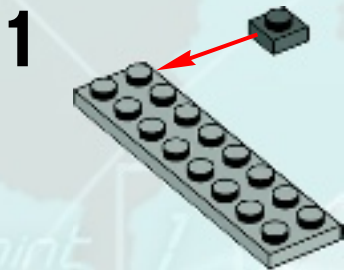



6

target
acquired

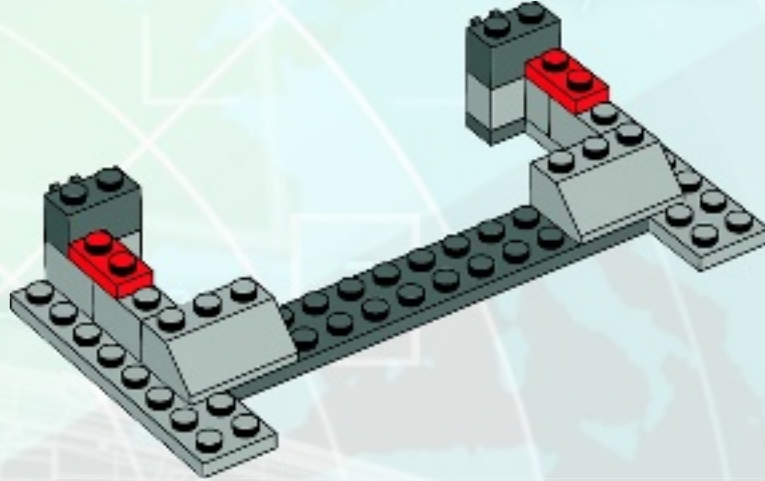

7

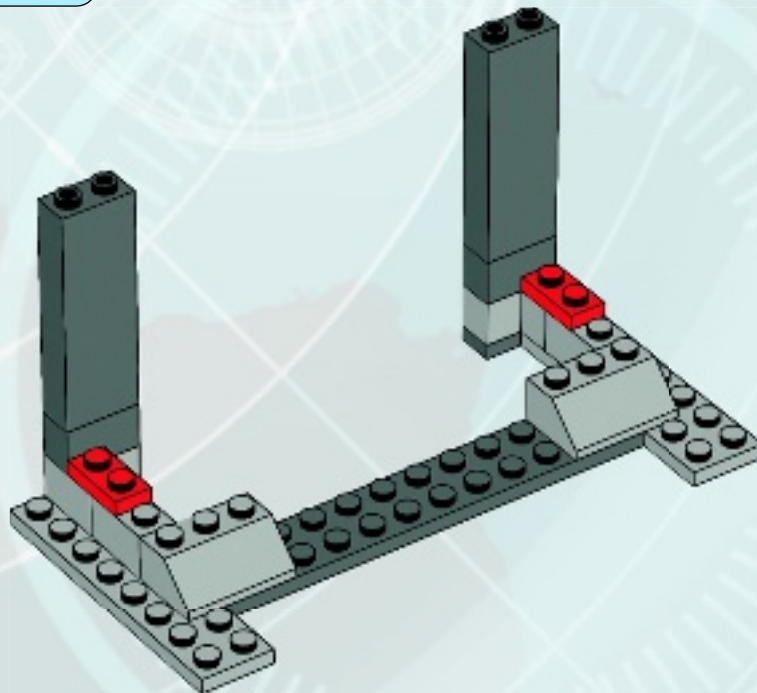

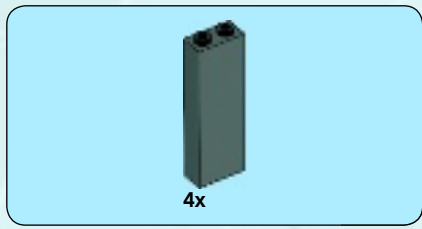

8

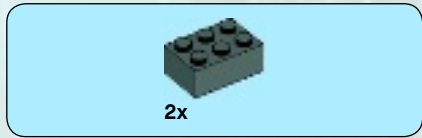
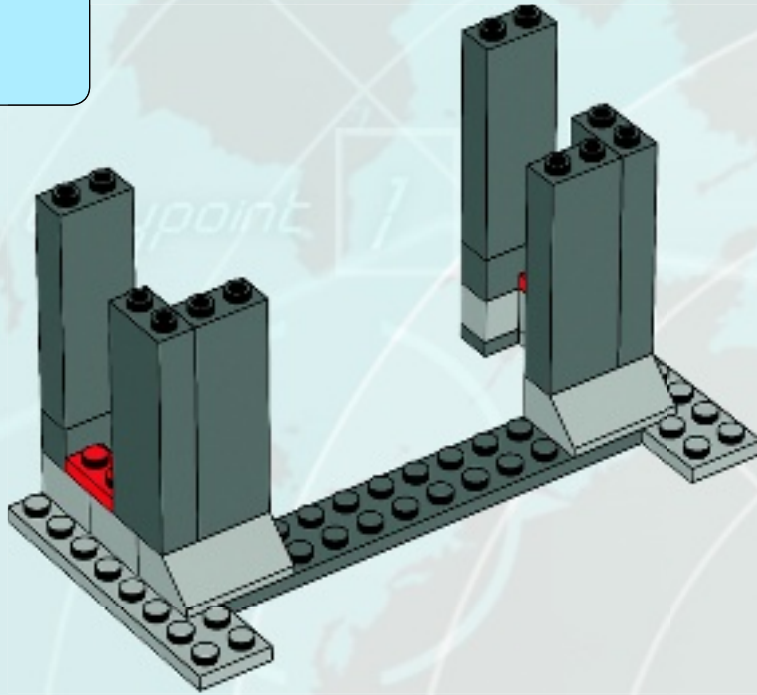

9

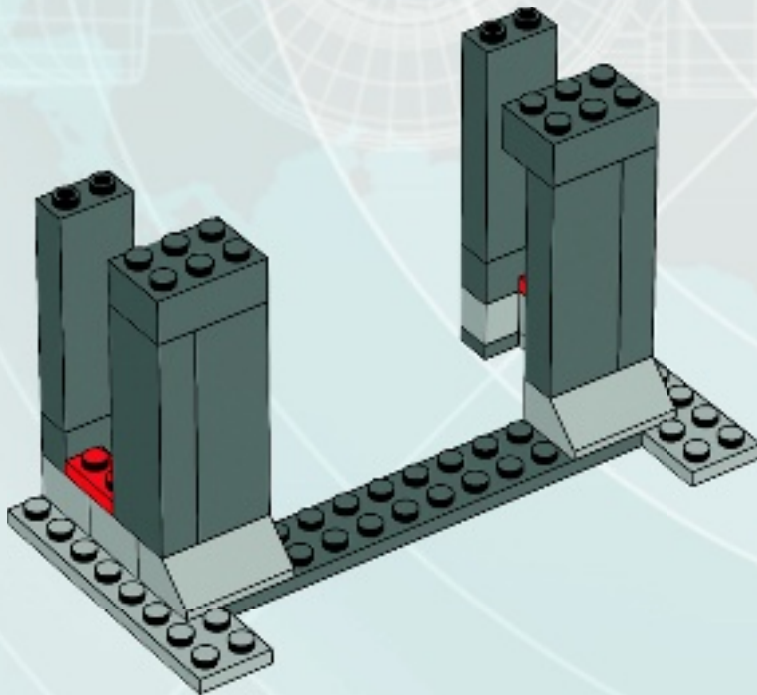

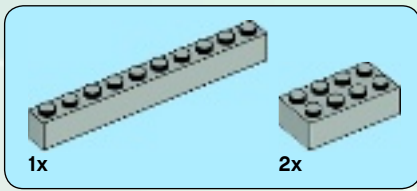

10

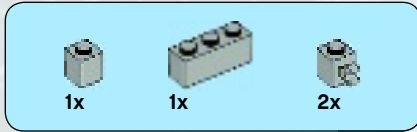
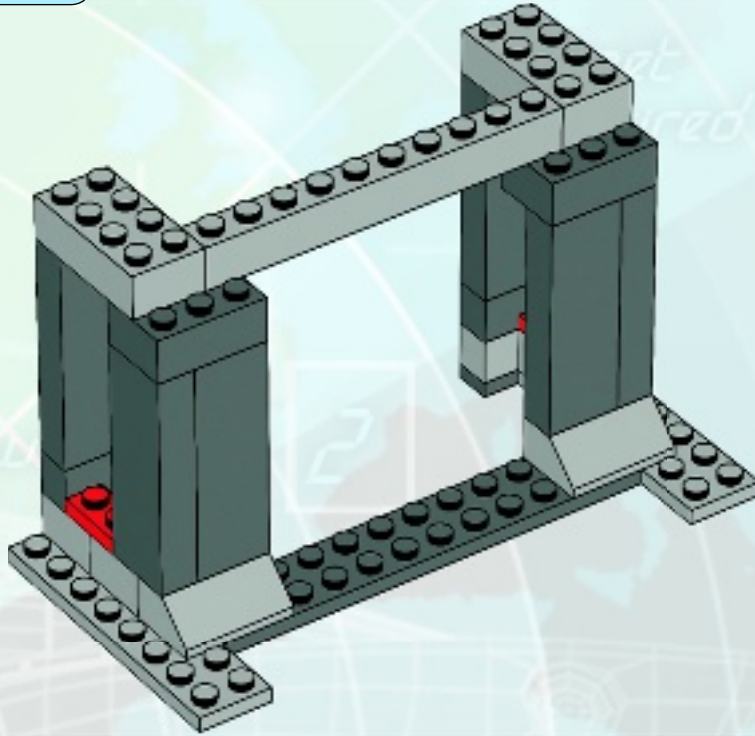

11

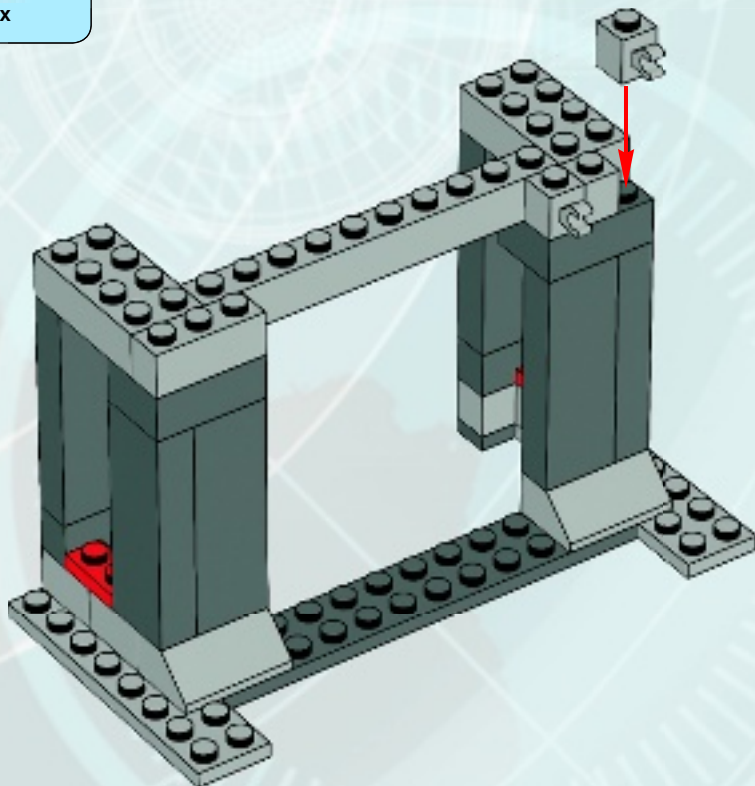

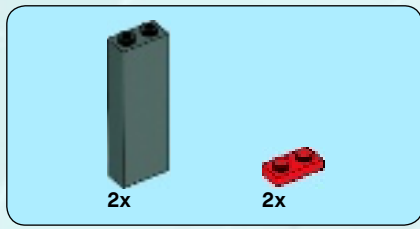

12

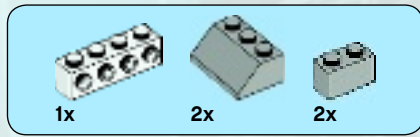
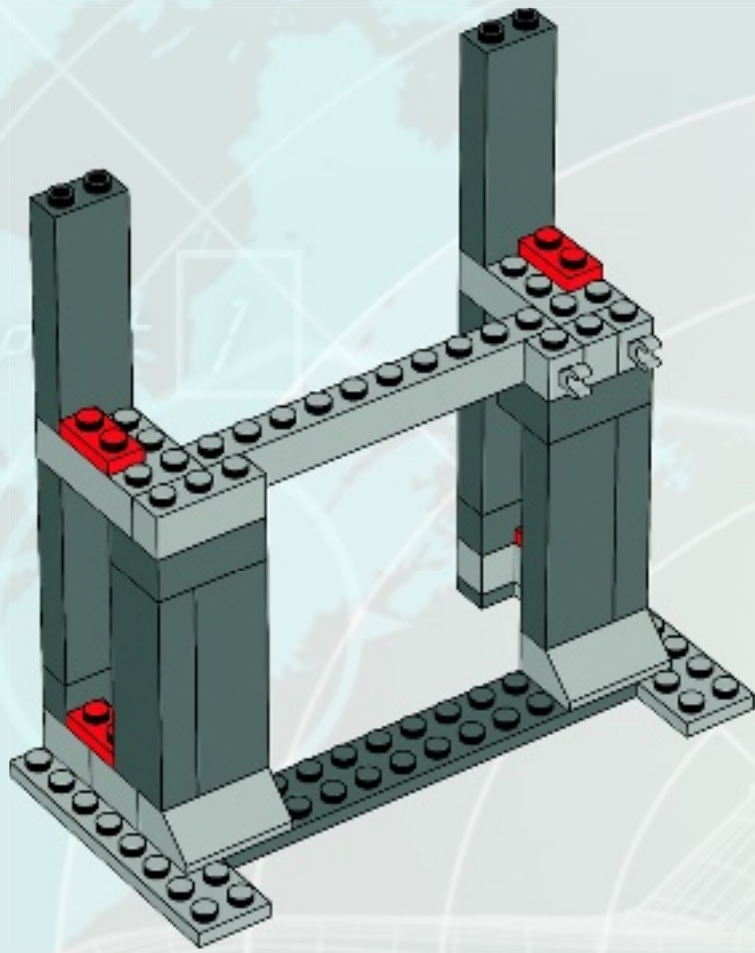

13

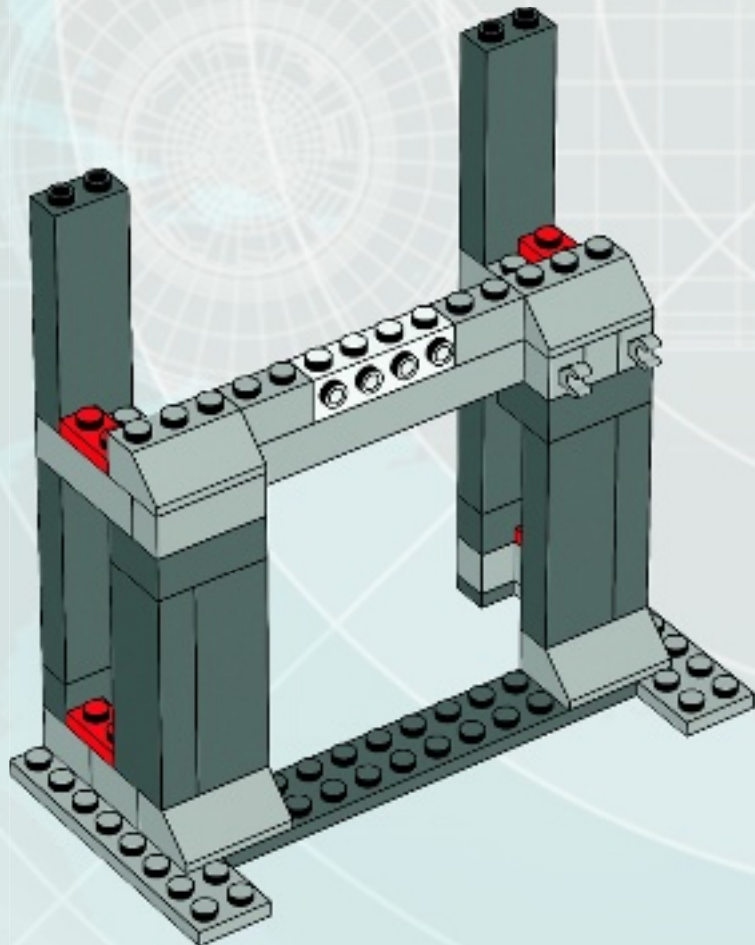

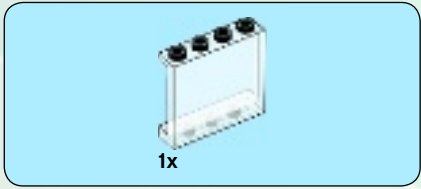

14

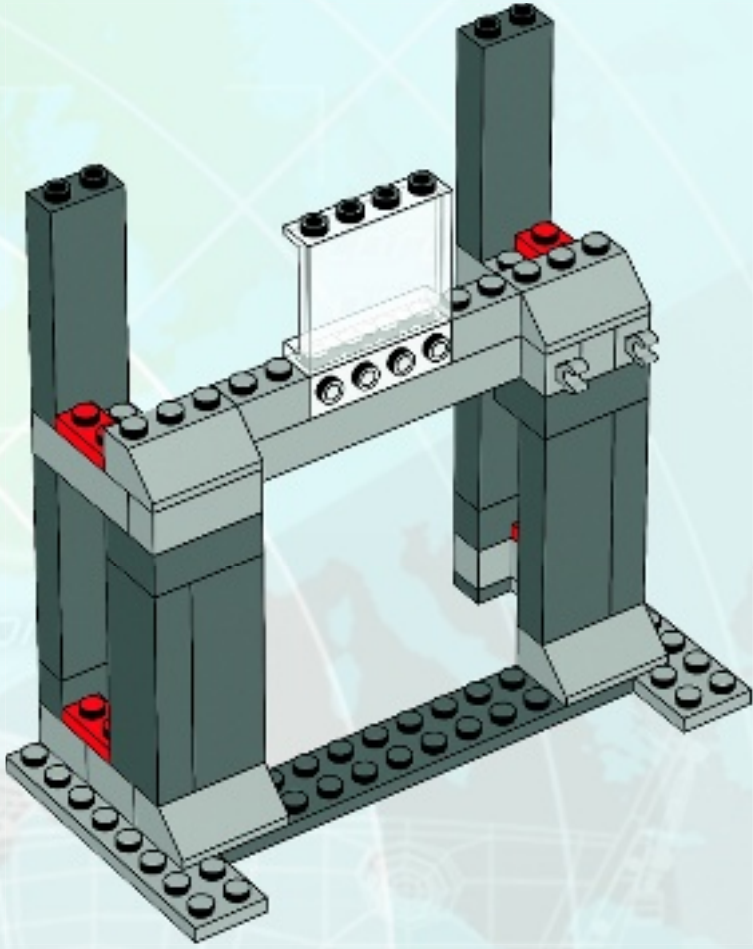

15

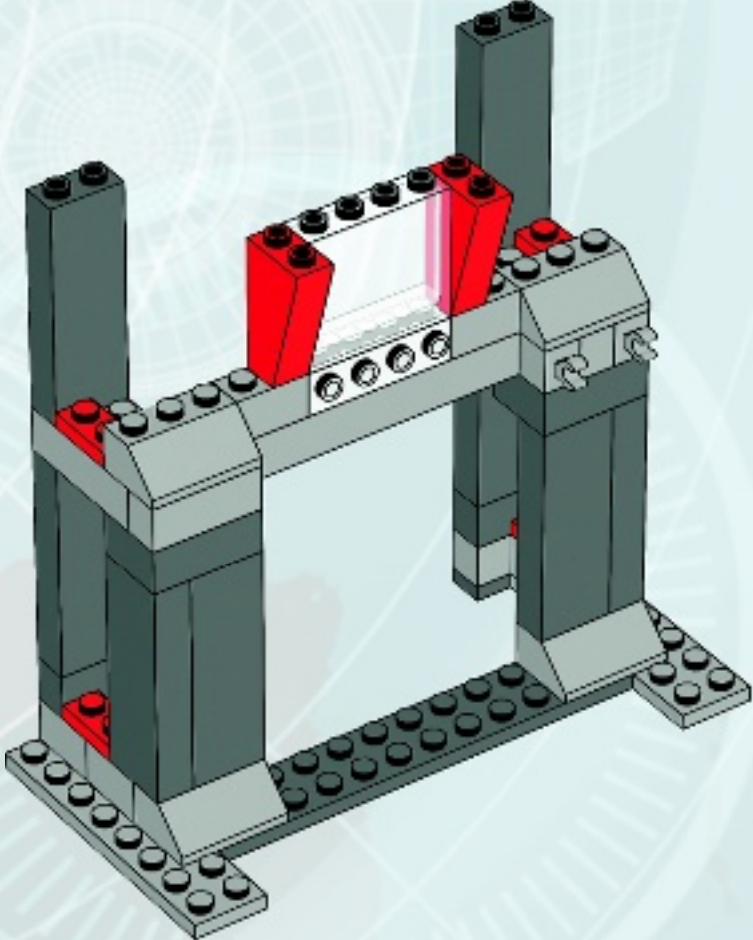

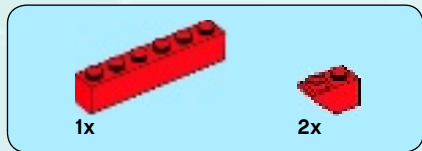

16

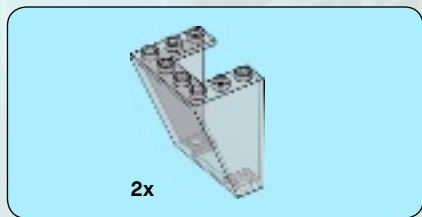
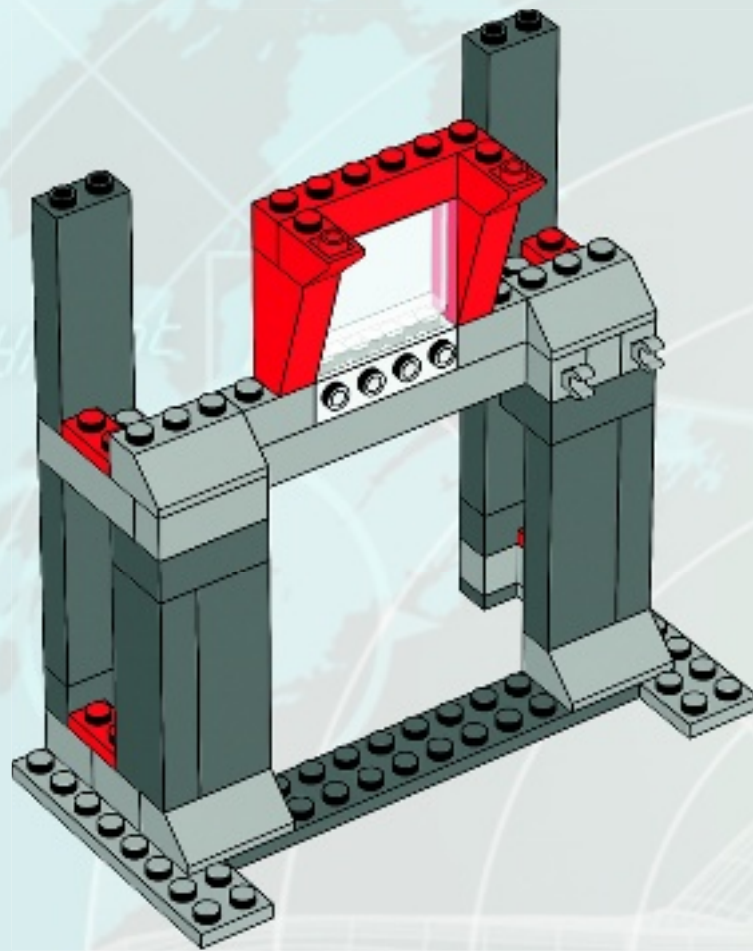

17

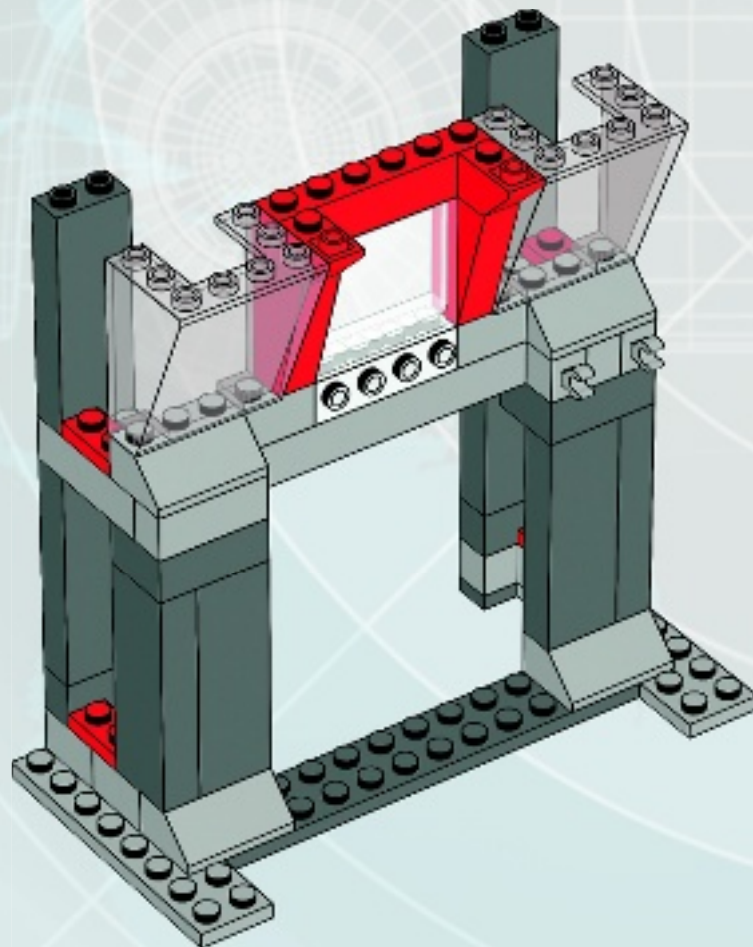

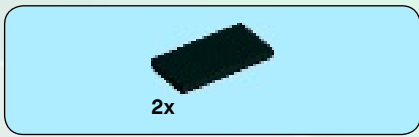

18

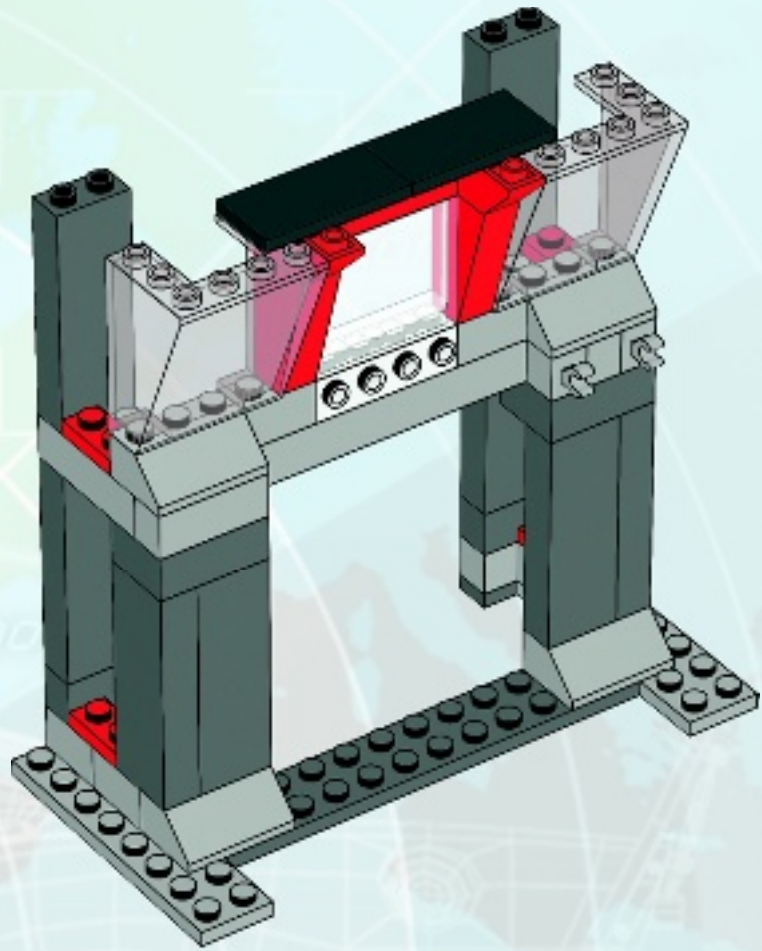

19

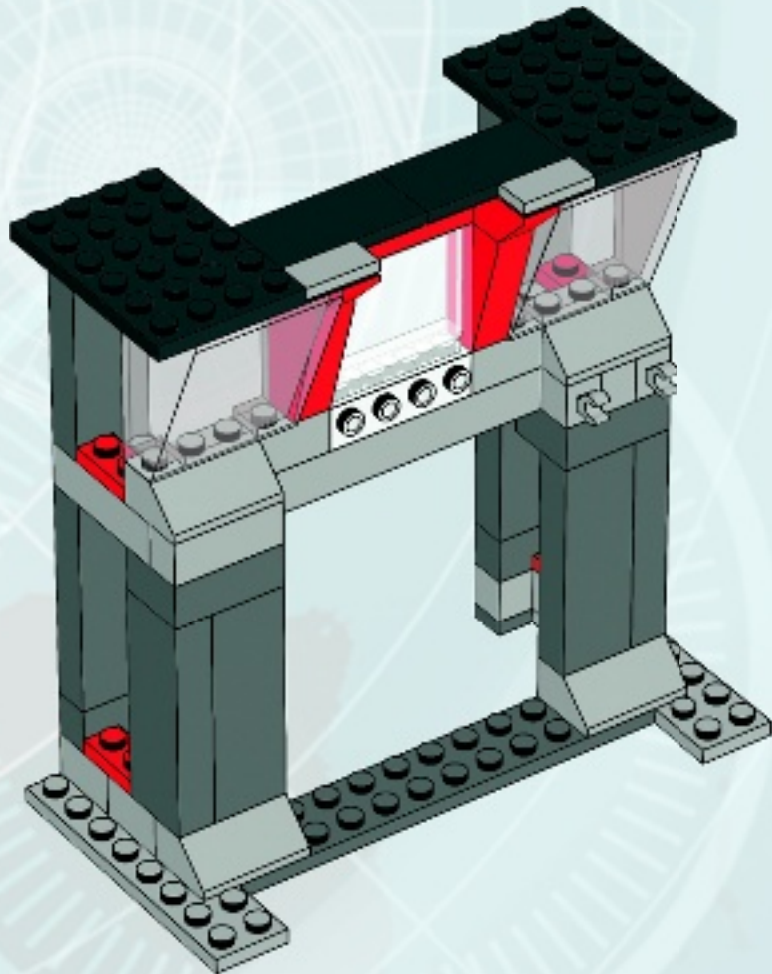

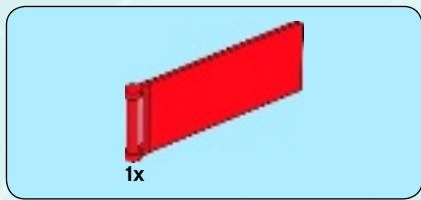

20

waypoint 1

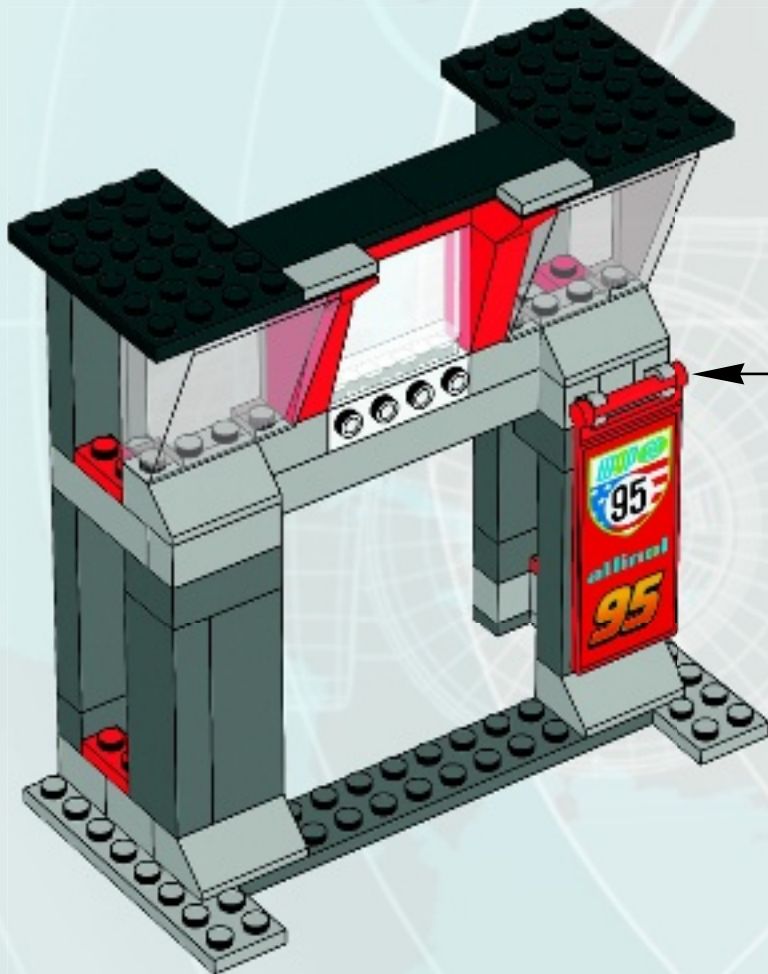

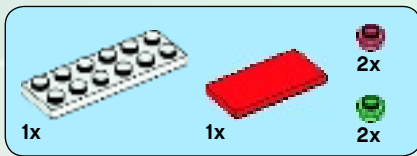

21

*target
acquired*

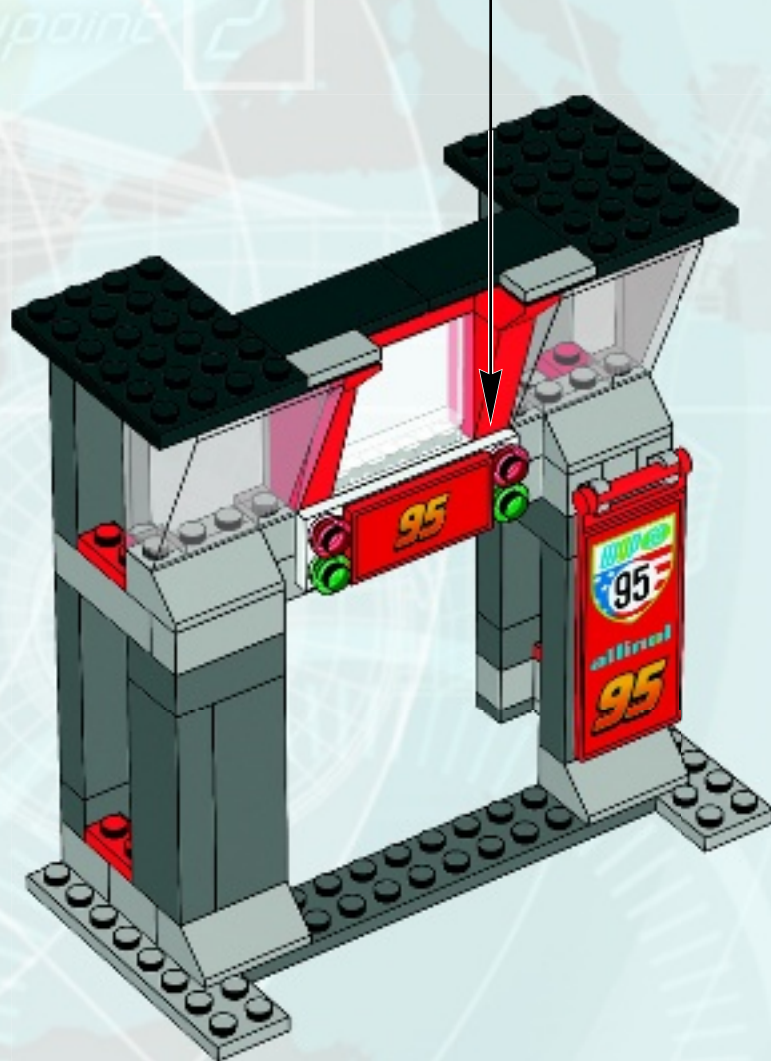
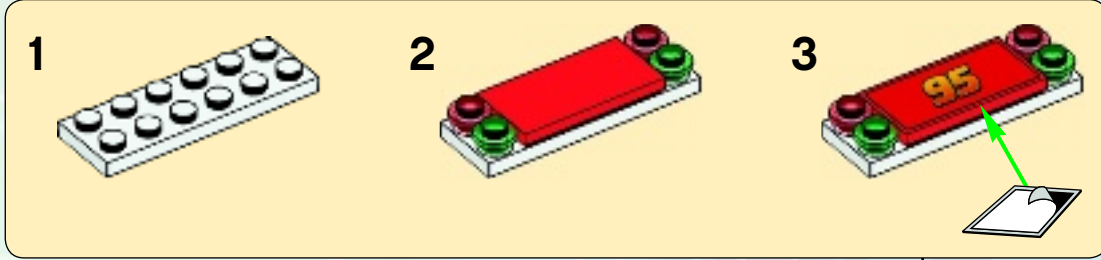



2x



2x

22

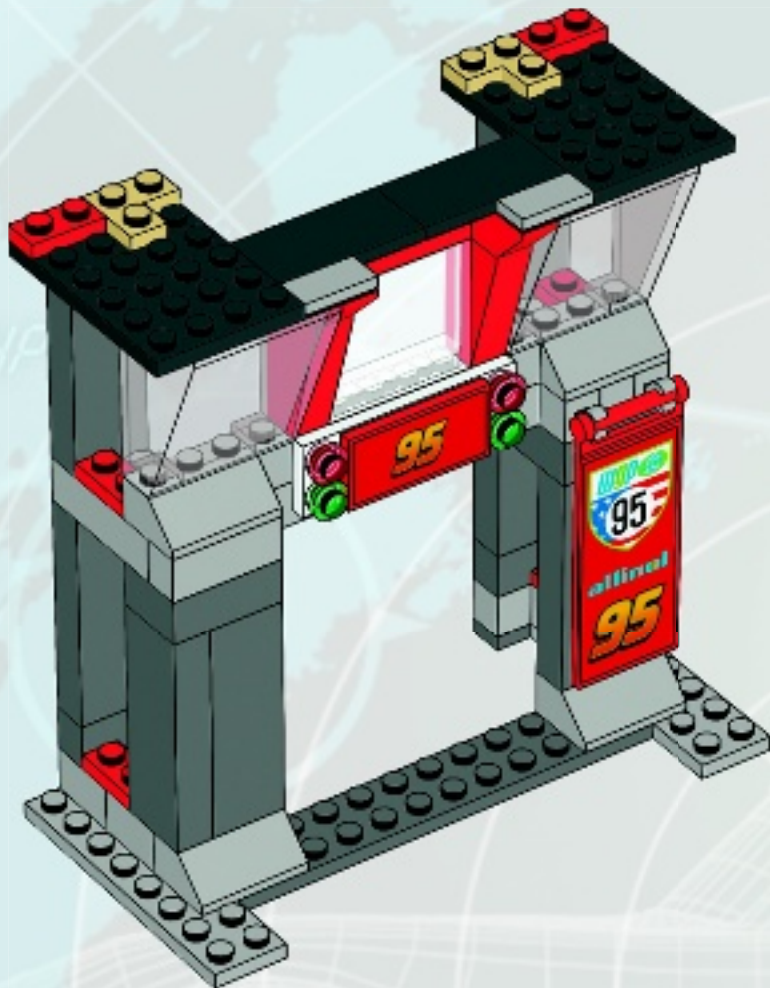

2x



2x

23

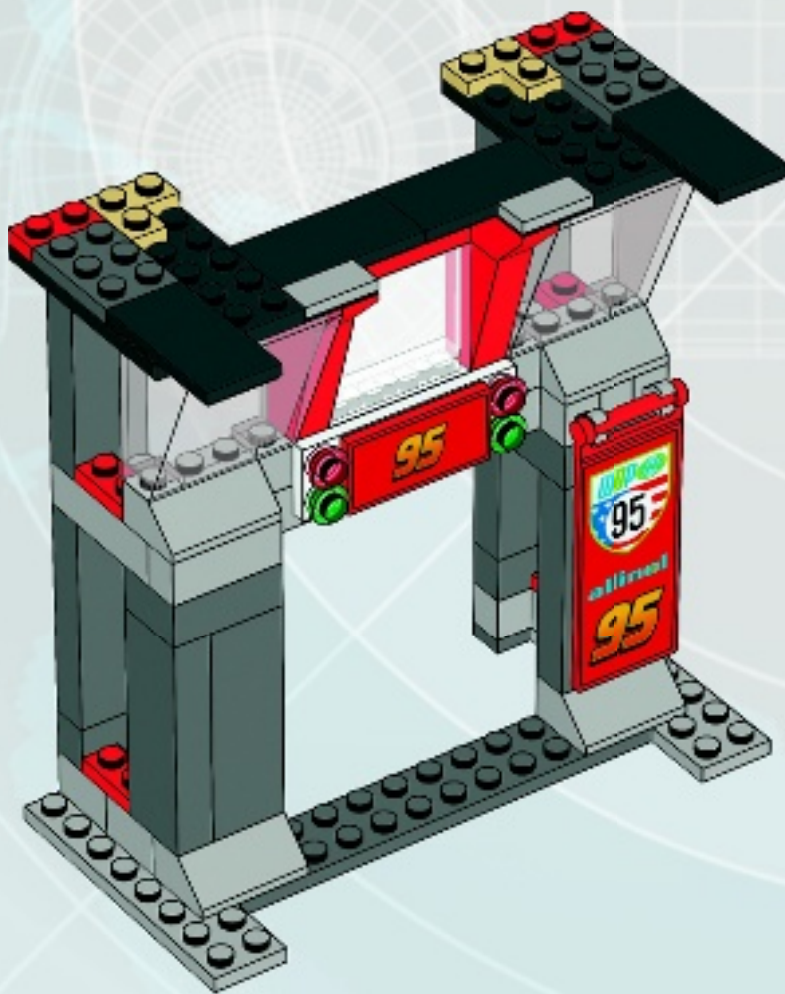

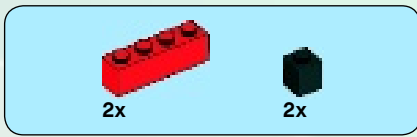

24

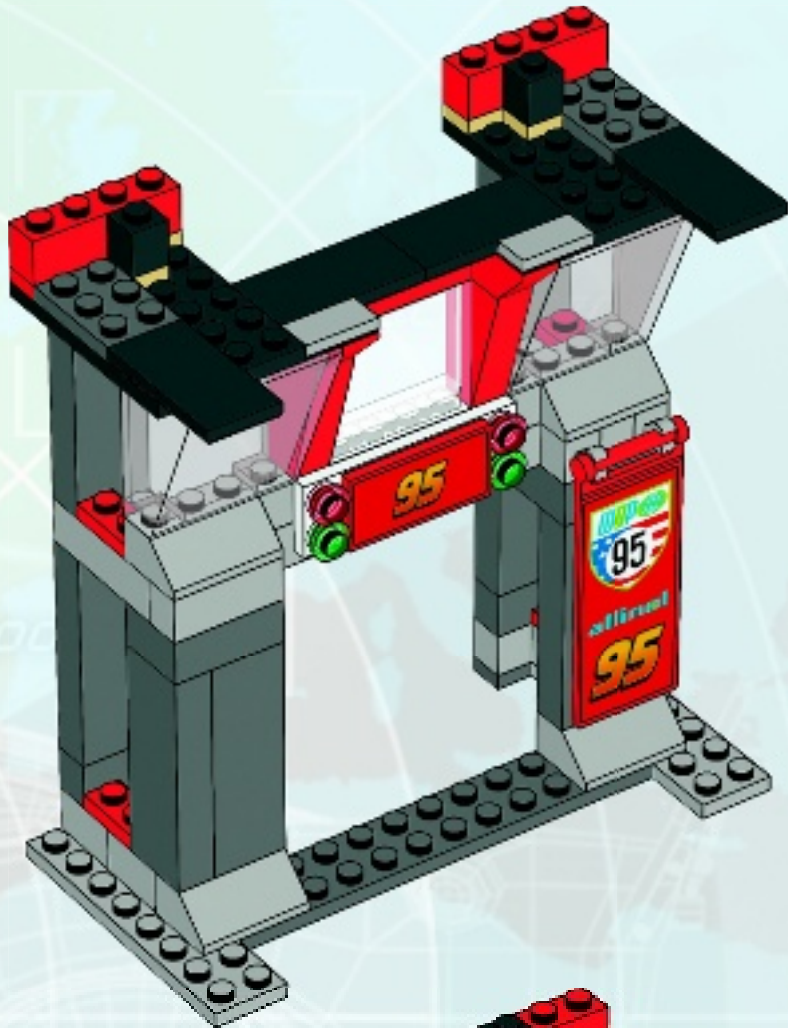

25

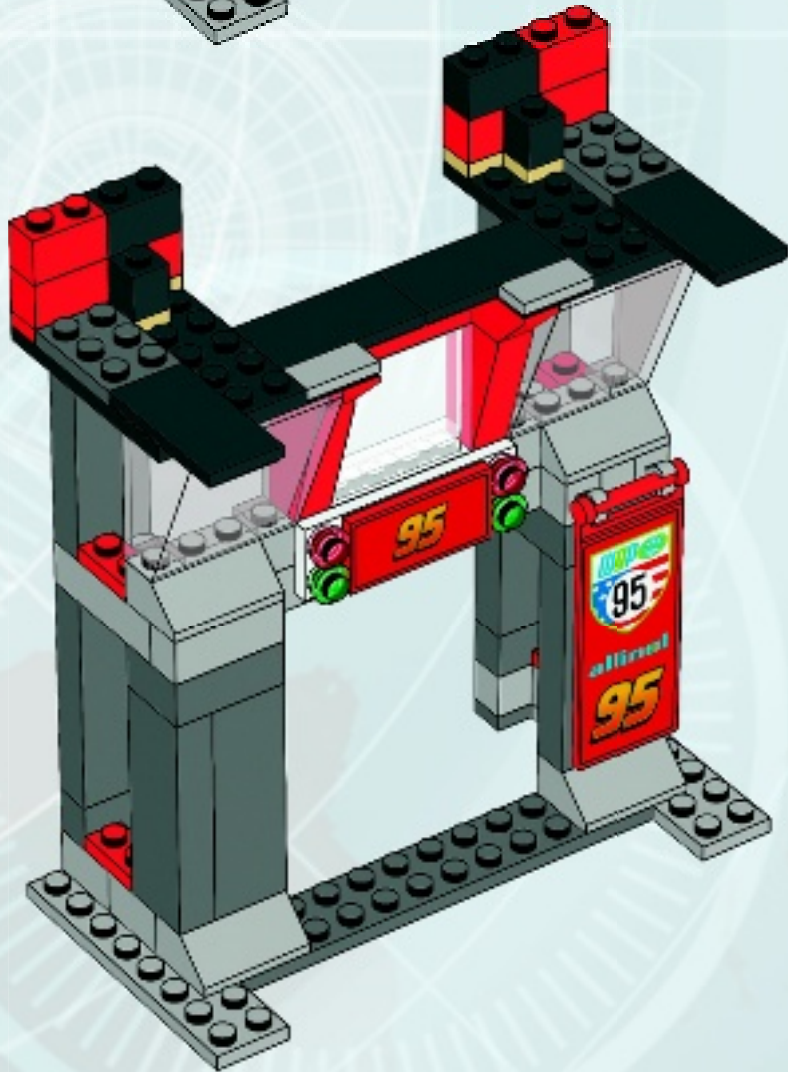



26

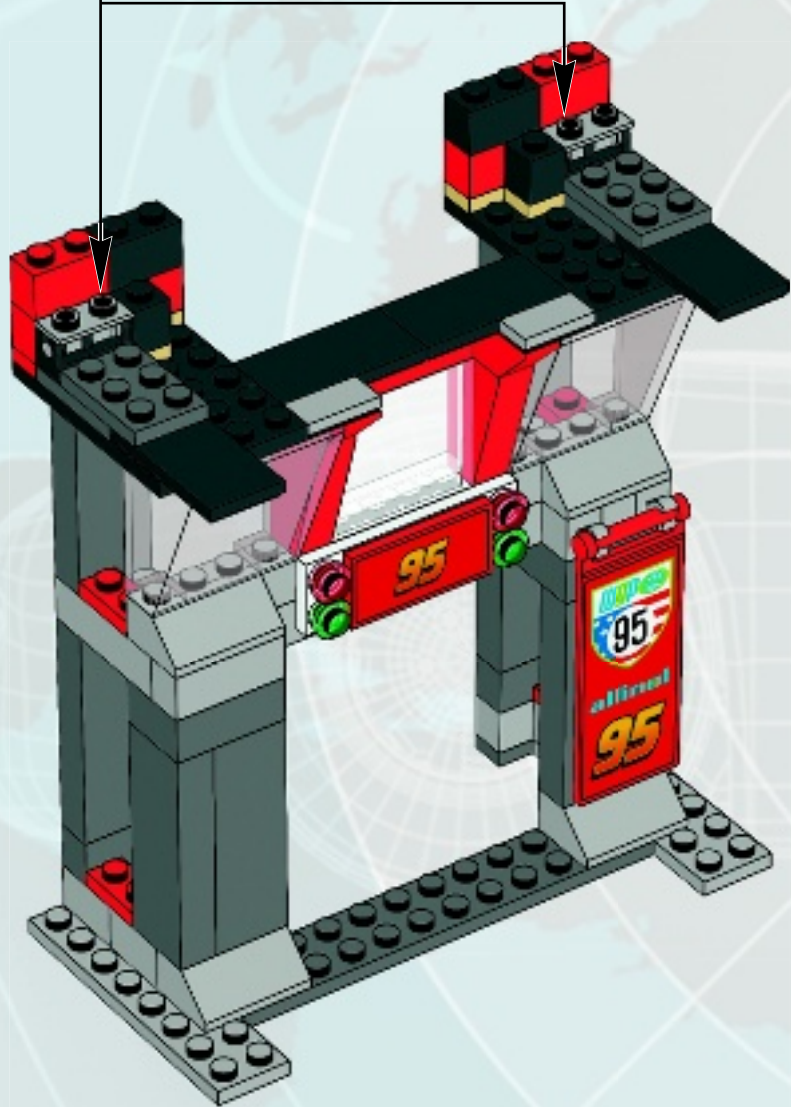
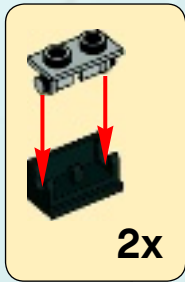

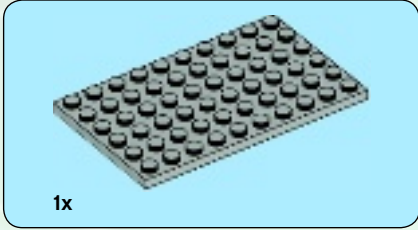
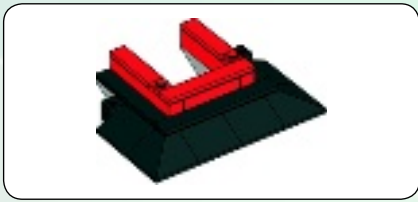

1

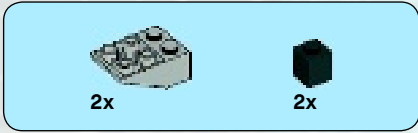

2

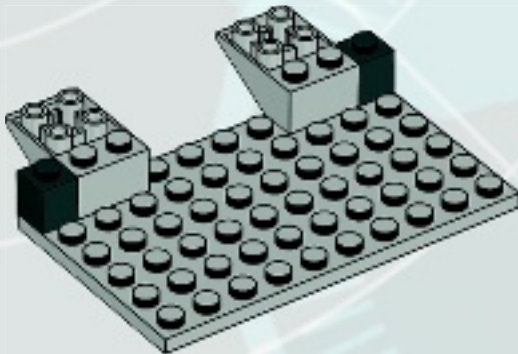

3

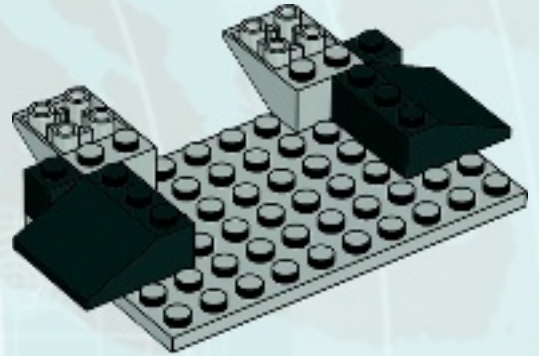

4

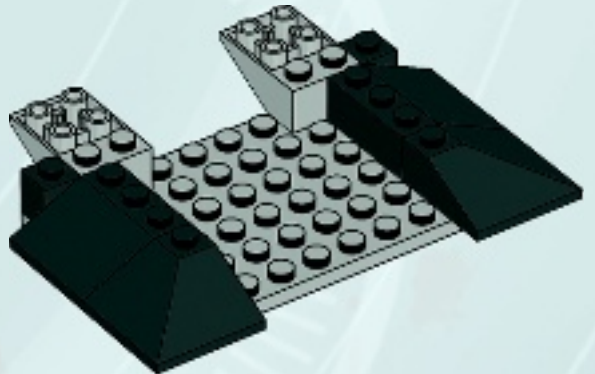



5

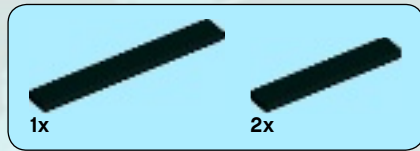
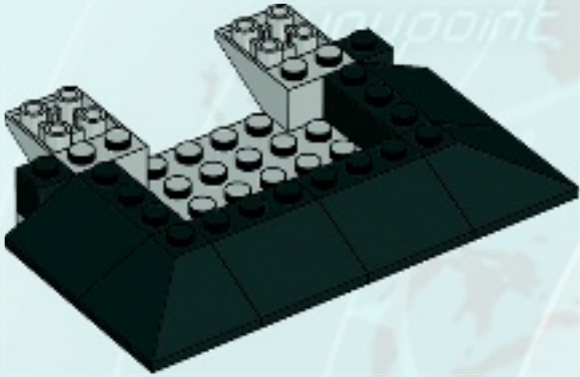

7

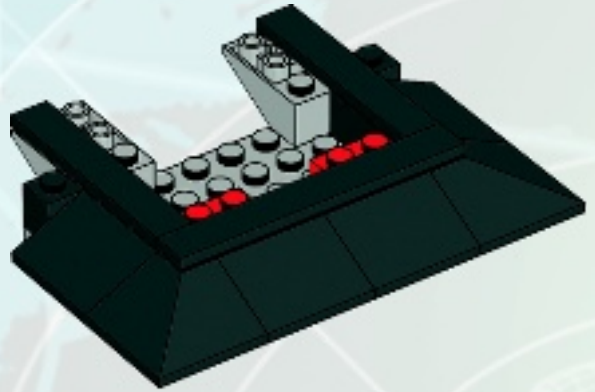

6

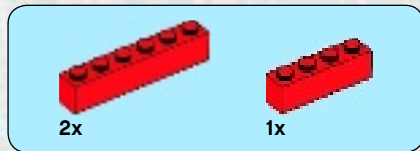
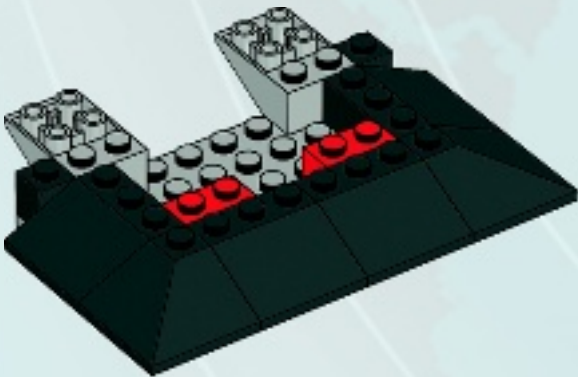

8

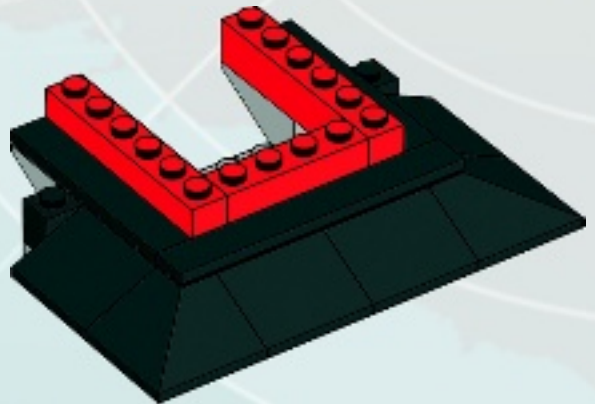

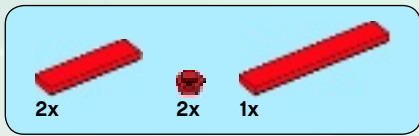

9

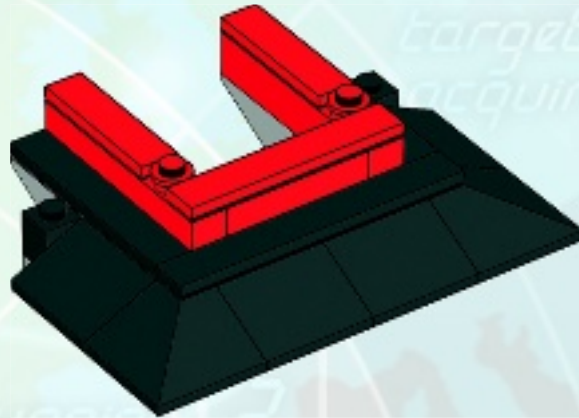

27

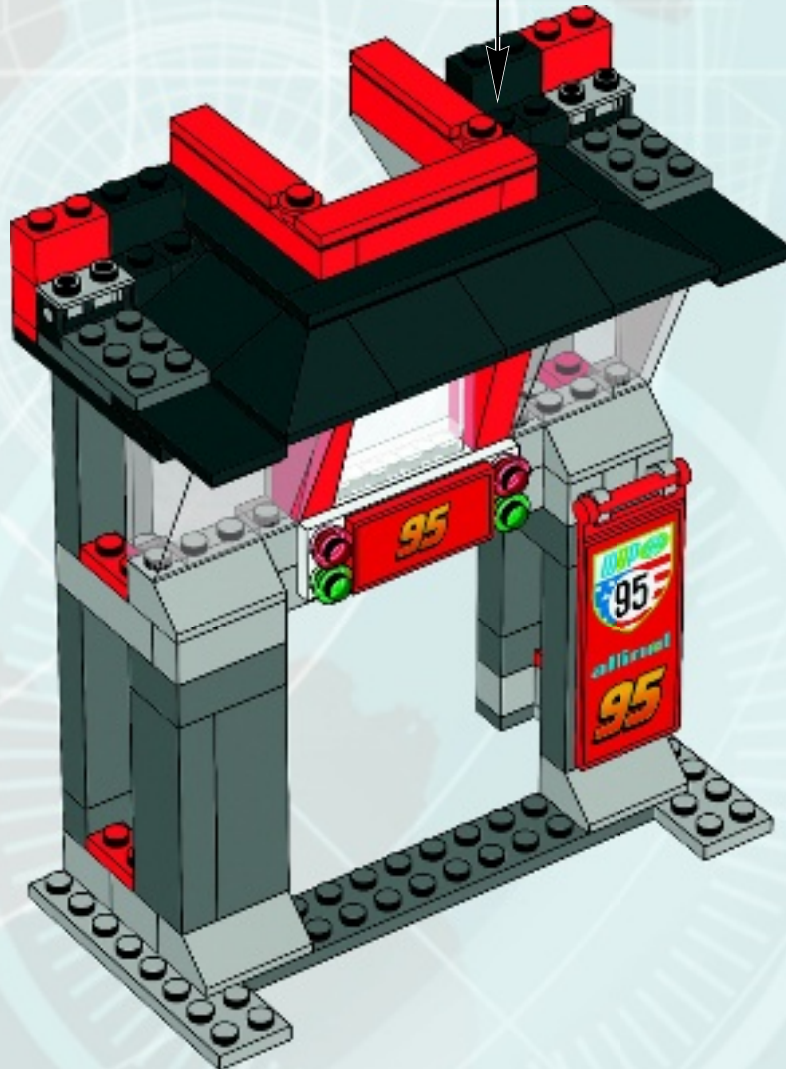

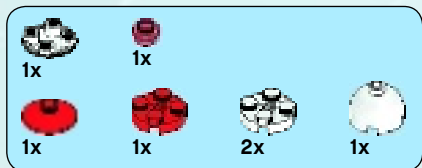

28

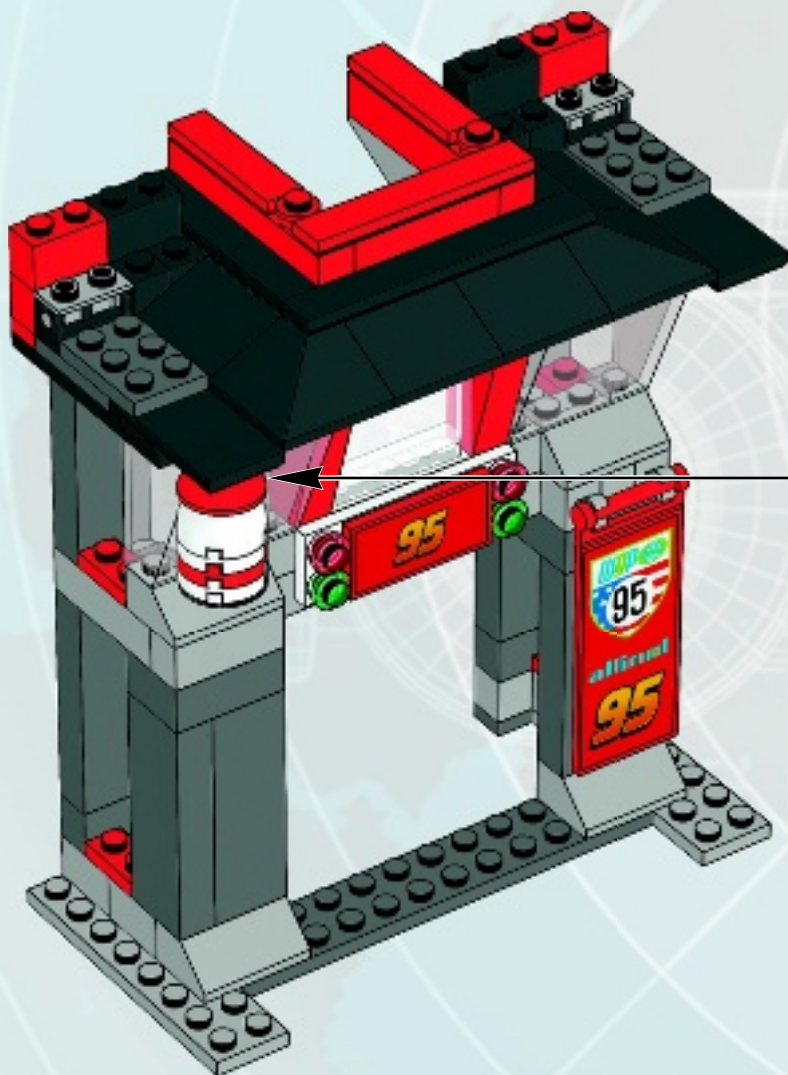

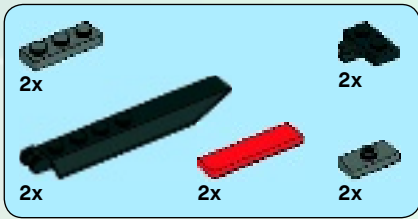

29

*target
acquired*

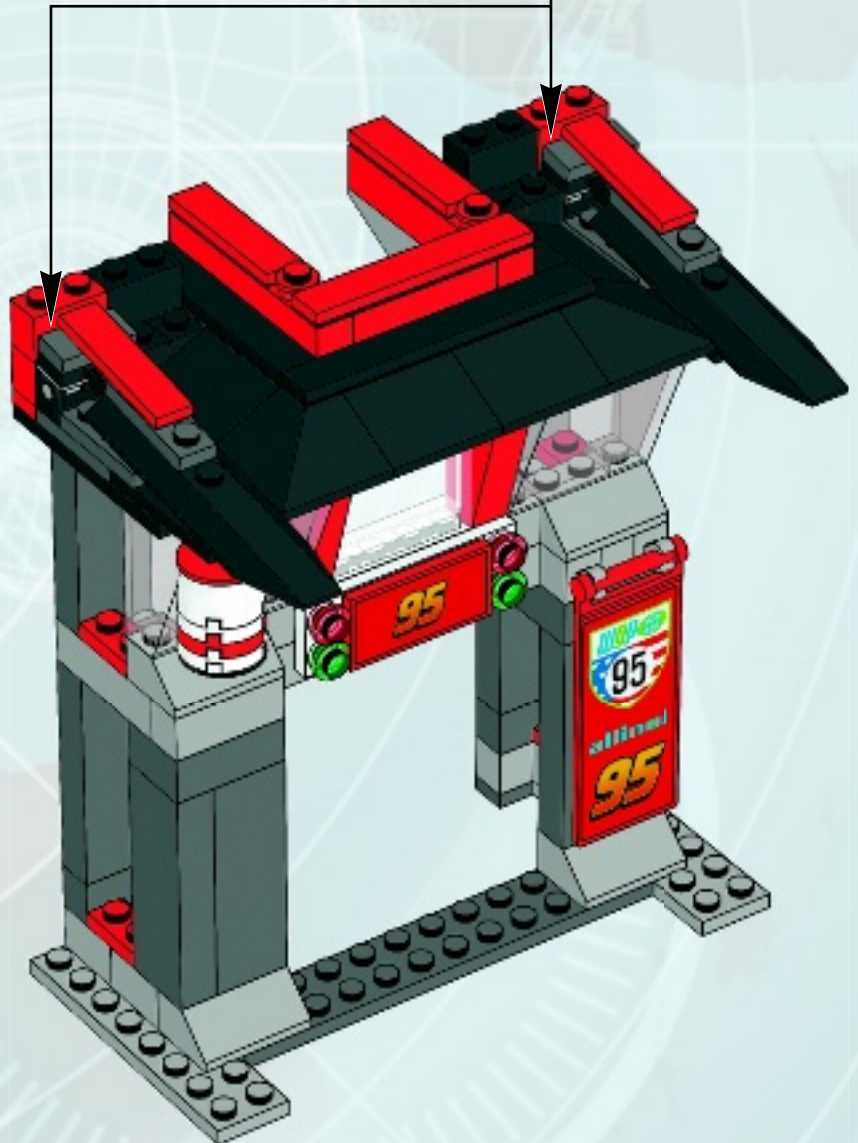
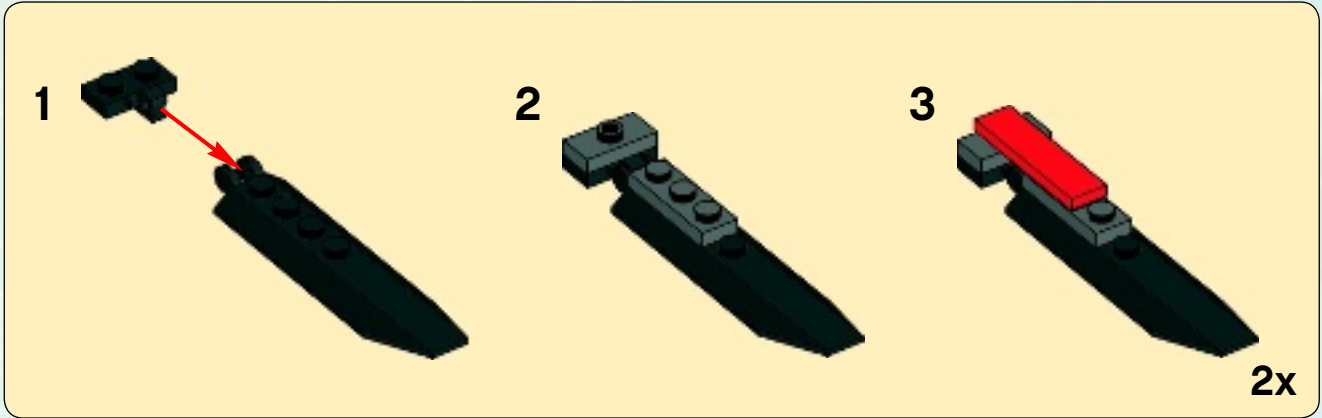

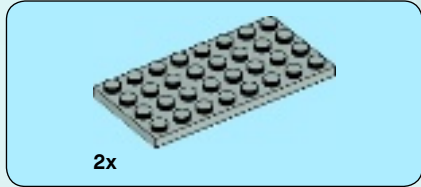
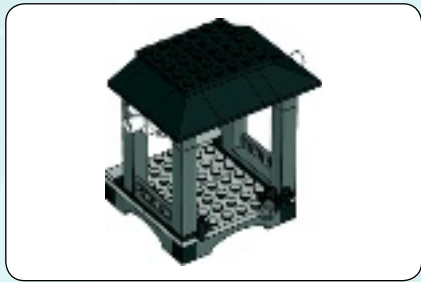

1

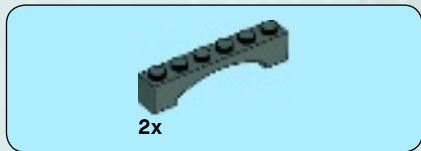
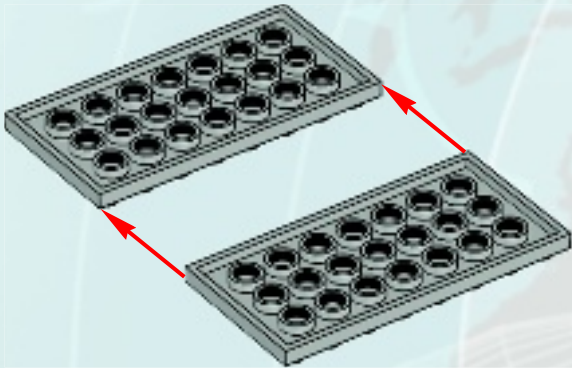

2

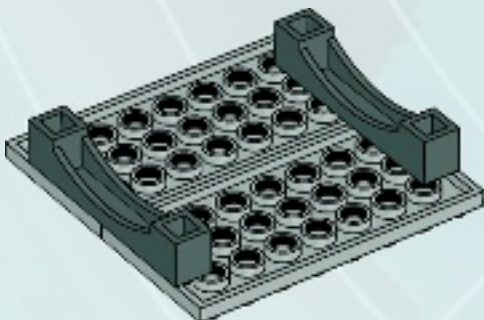

3

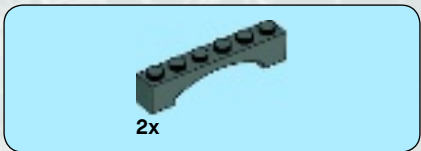
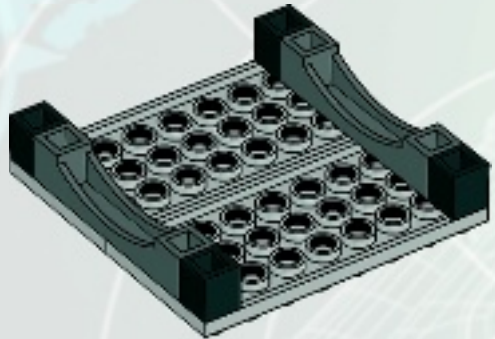

4

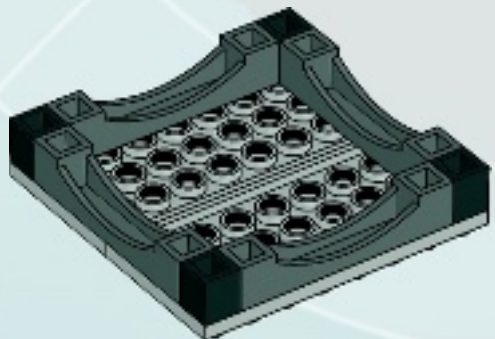

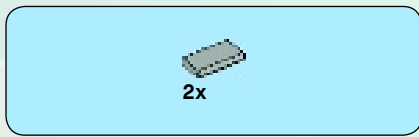

5

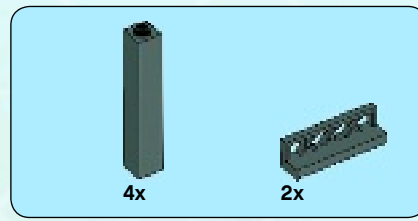
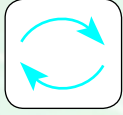

7

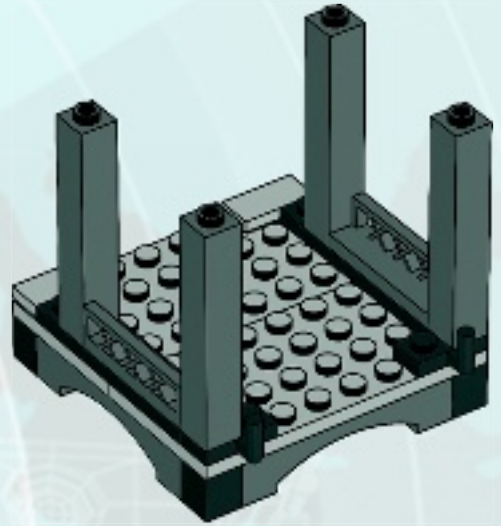

6

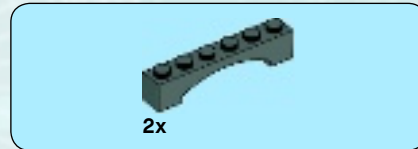
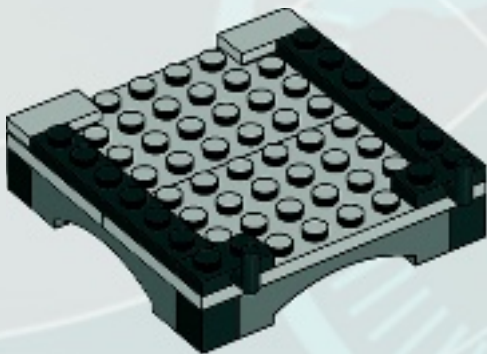

8

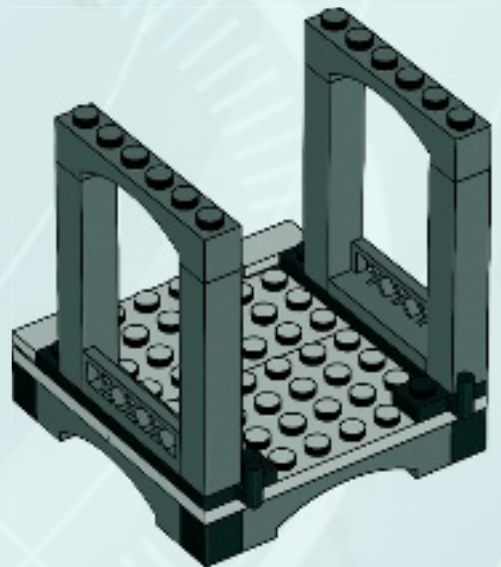

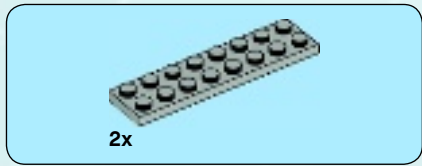

9

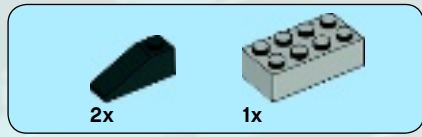
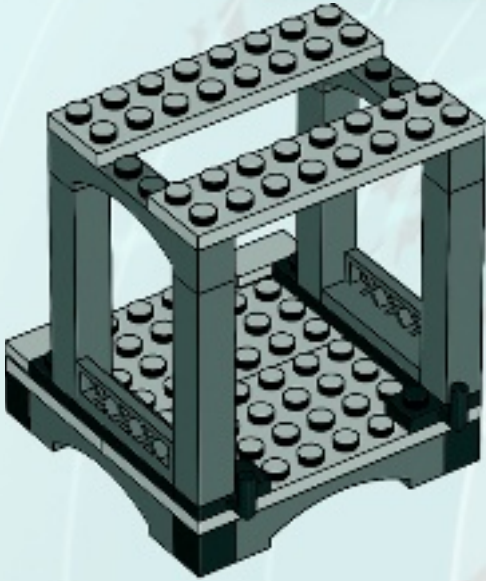

11

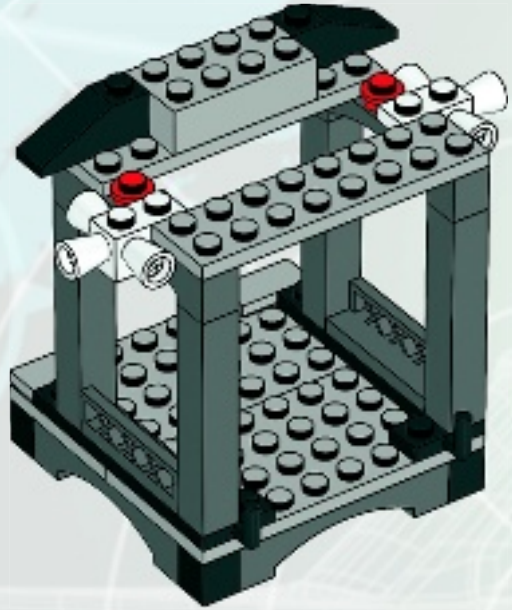

10

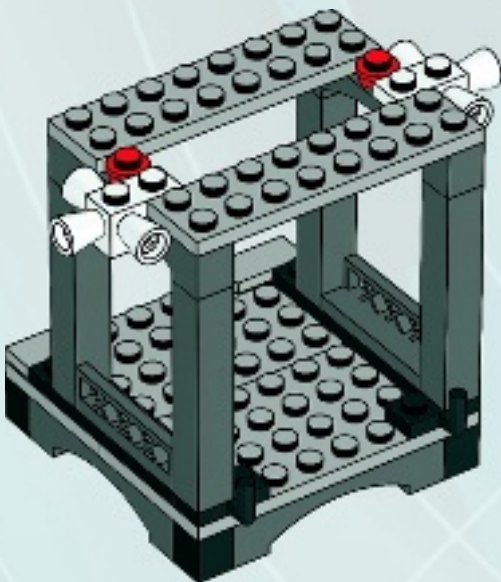

12

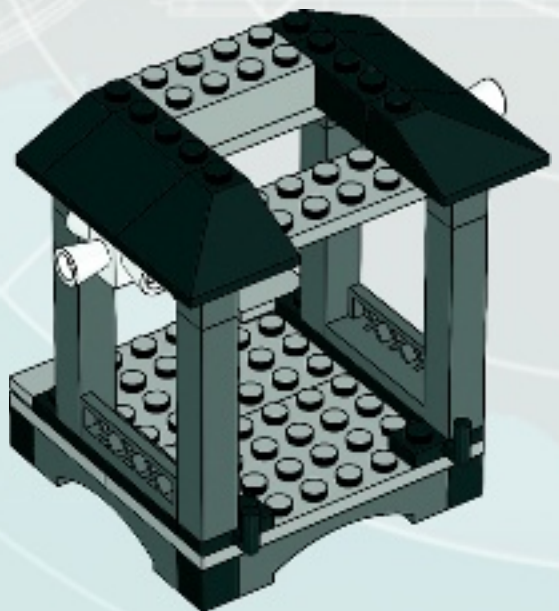



13

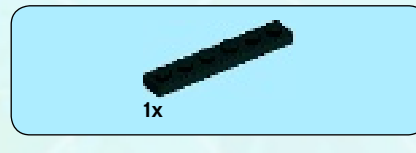
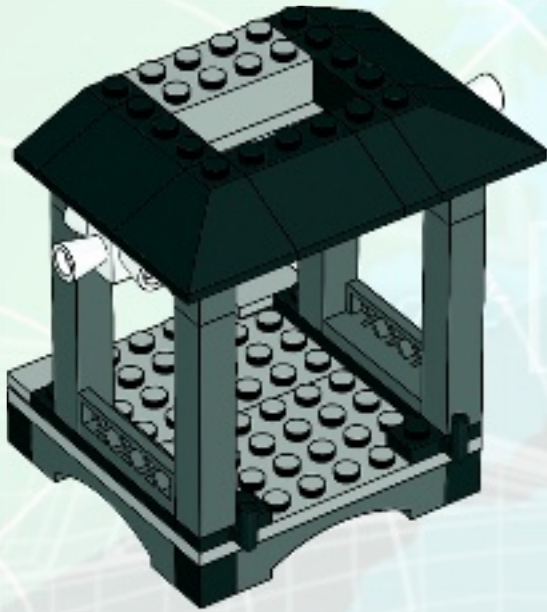

15

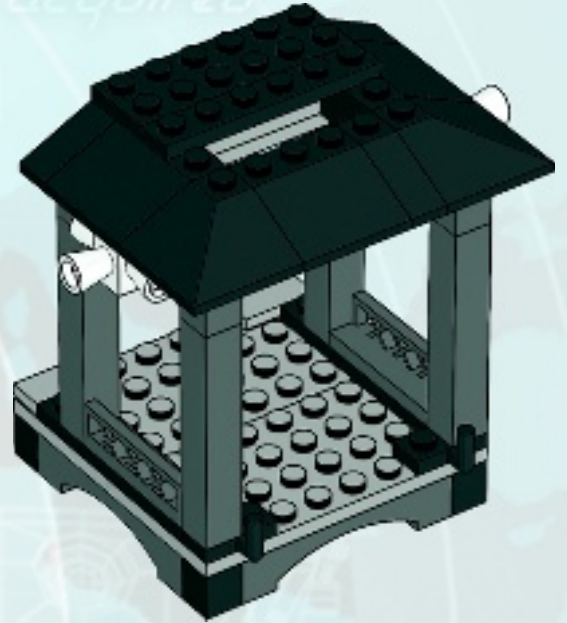

14

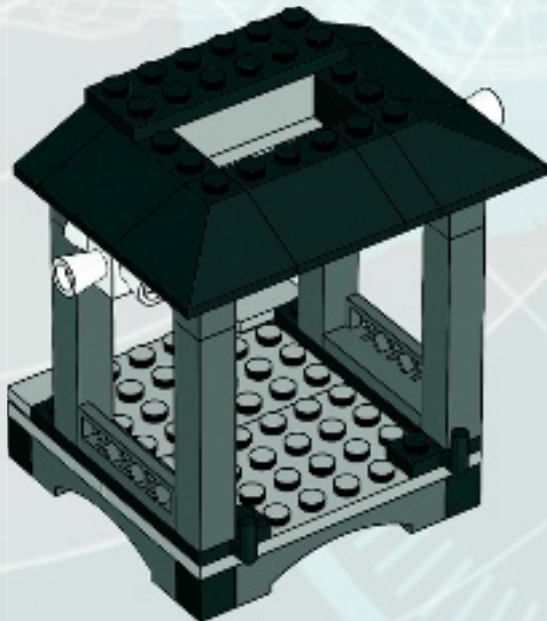

16

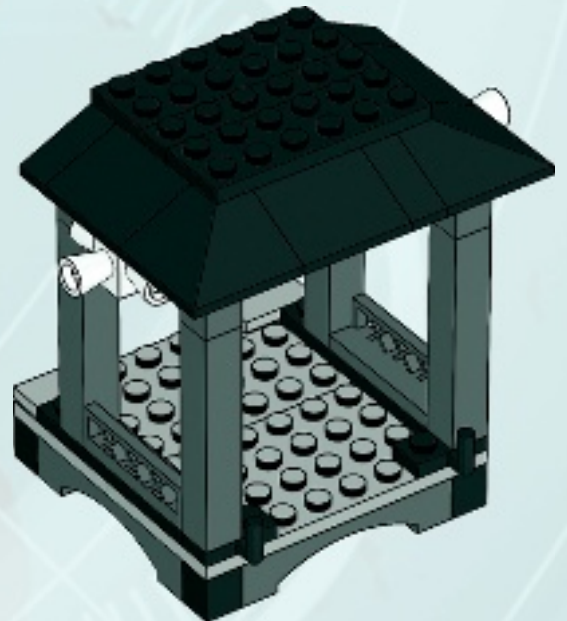

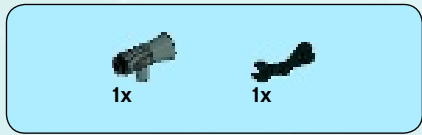

17

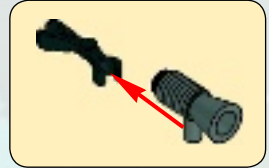
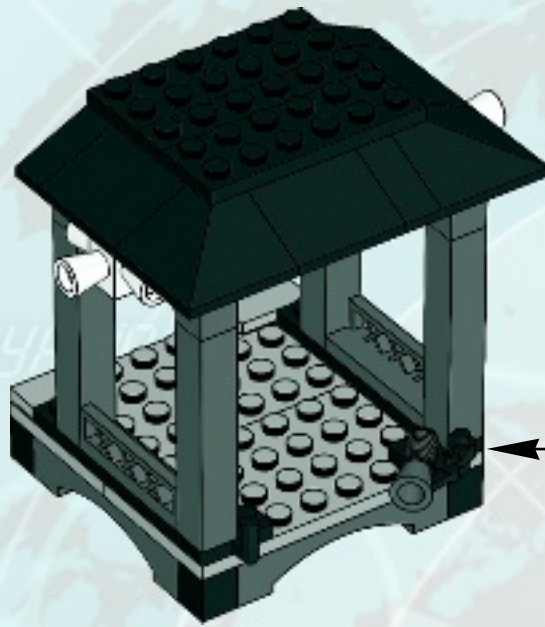

30

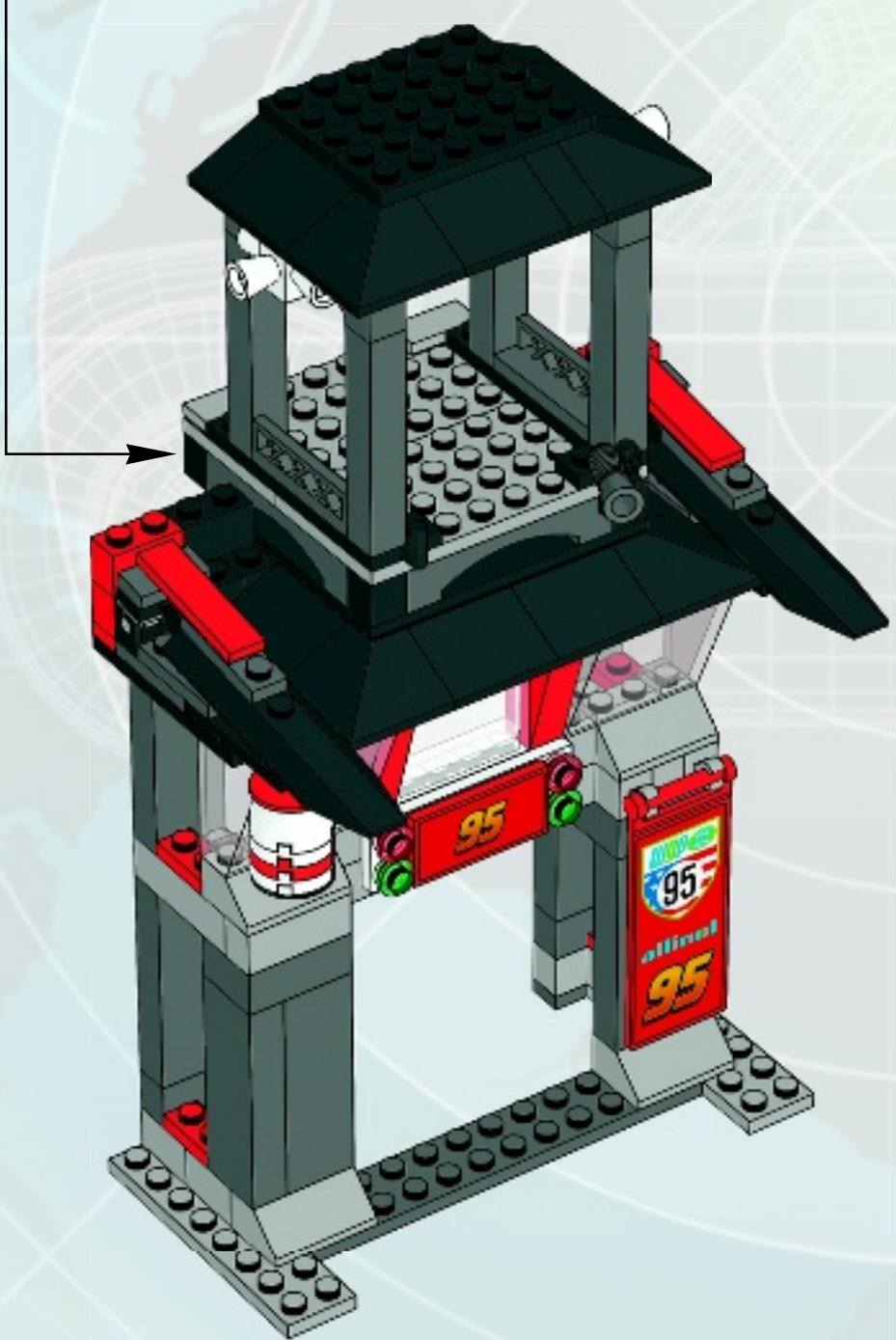

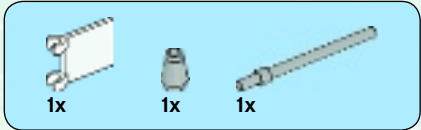

31

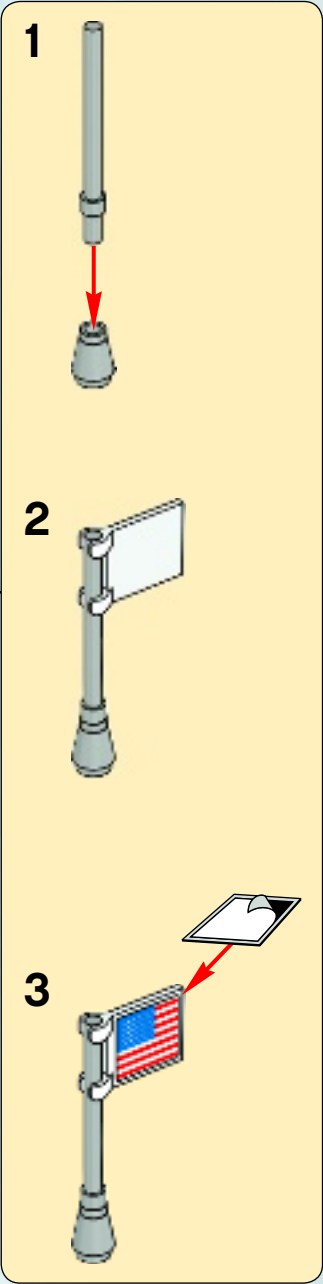
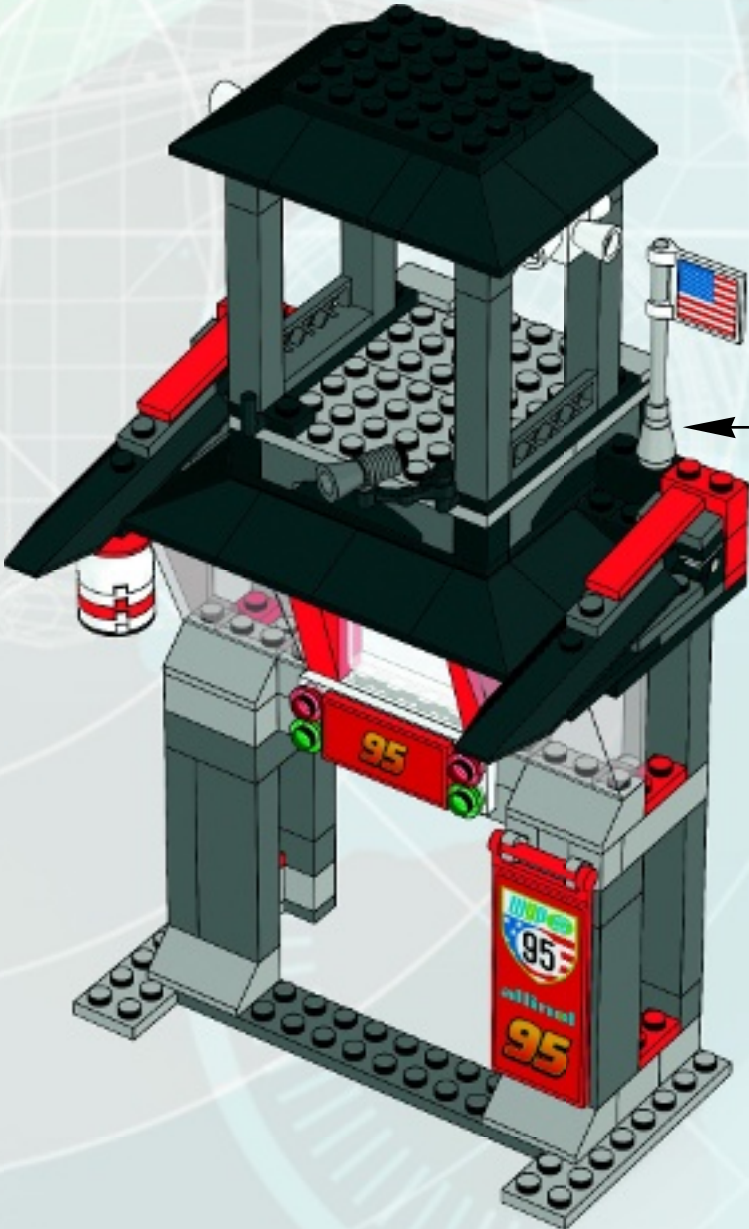

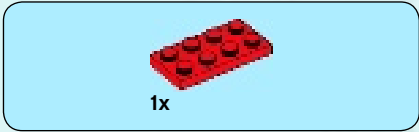

1x

1



2x

2



1x

1x

3

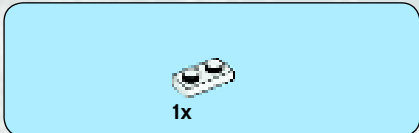

1x

4





5

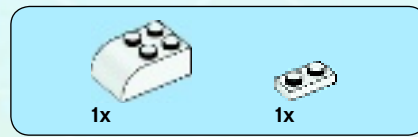
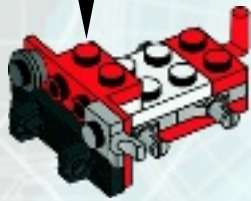
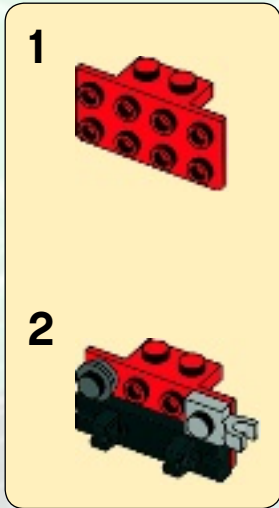

6

target
acquired



7

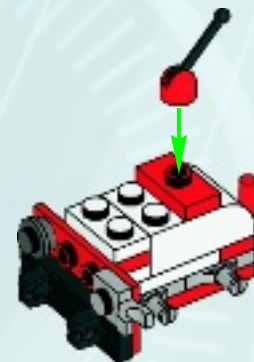



1x

8



2x

10



1x



2x

9

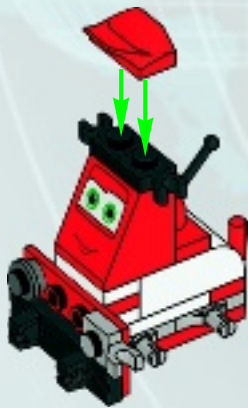

2x

11





4x



4x

12



1x



1x

13

1

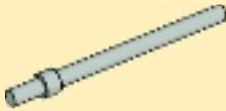

2

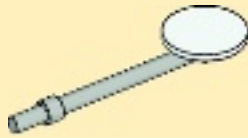

3

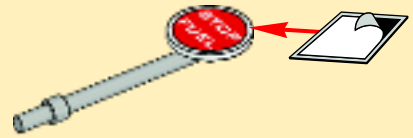



1x

1



2x

2



1x



1x

3

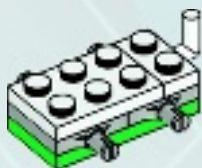

1x



1x

4

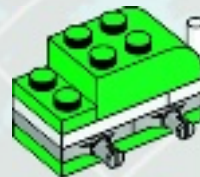

1x



1x



1x



1x

5

1



2

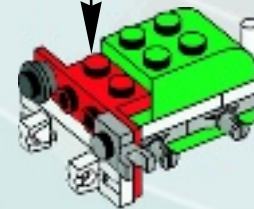
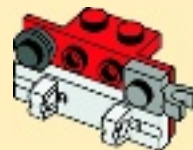



1x



2x

6

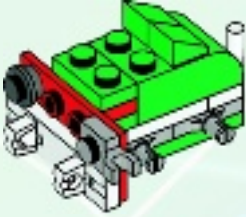

1x

7



1x



2x

8

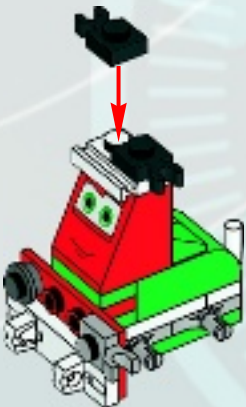

2x

9



2x



2x

10

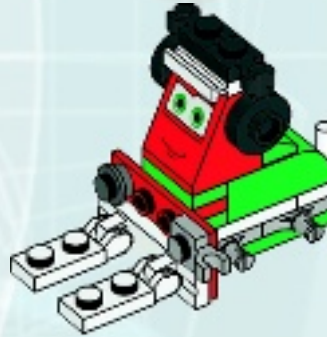

4x



4x

11



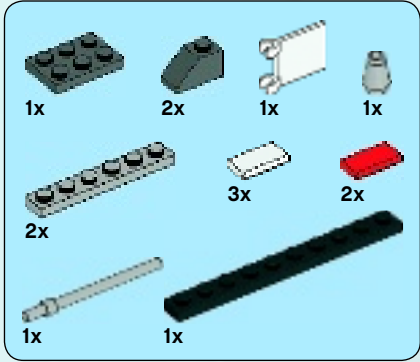

1

1



2

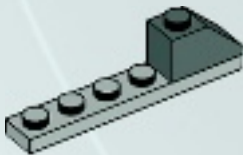

3



4

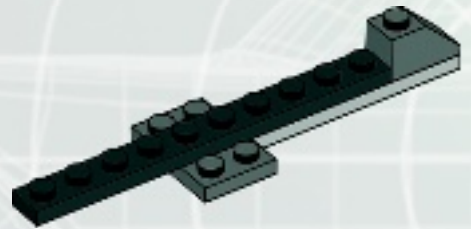

5

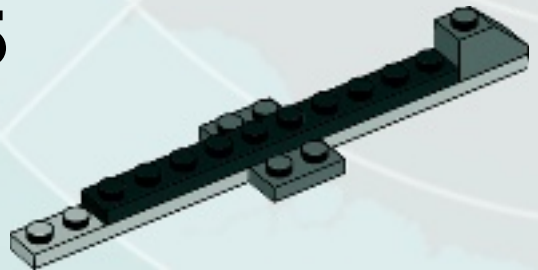

6

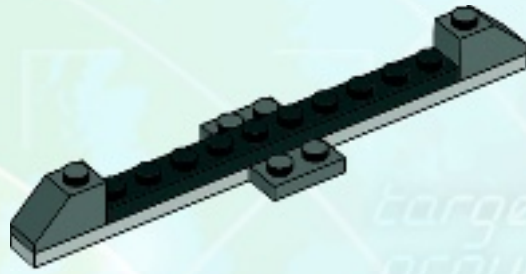

target
acquired

7

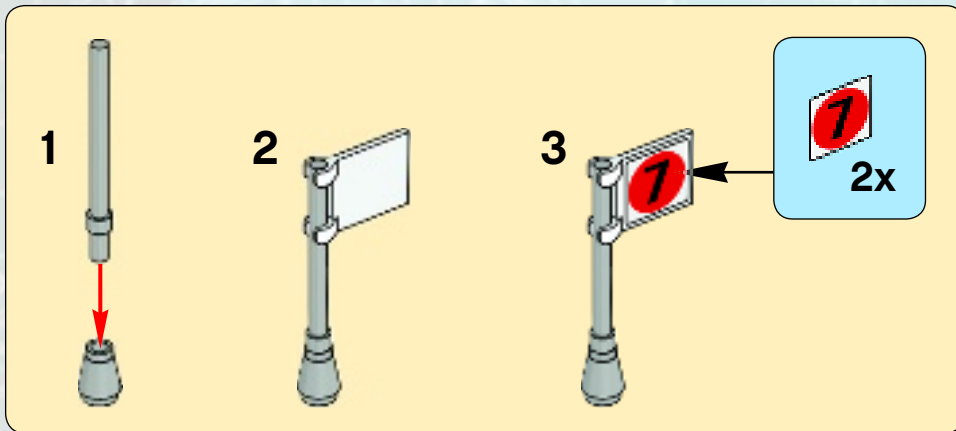

8

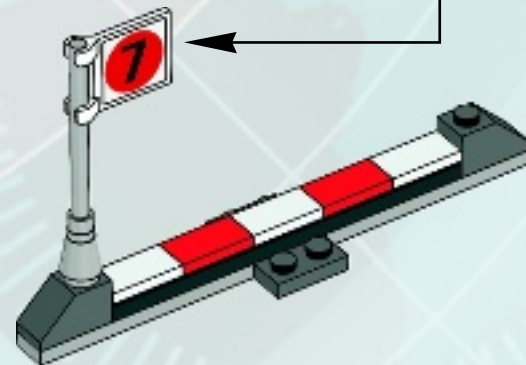

6

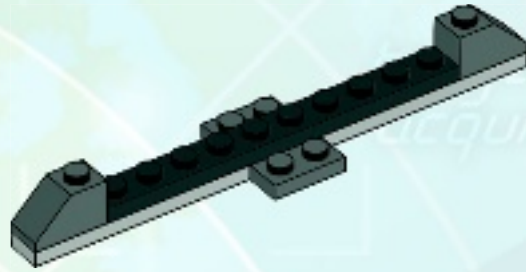

7

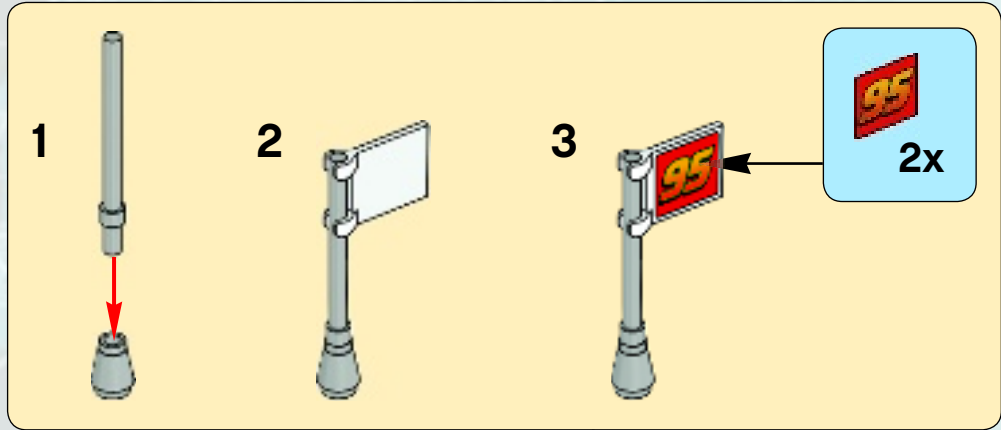
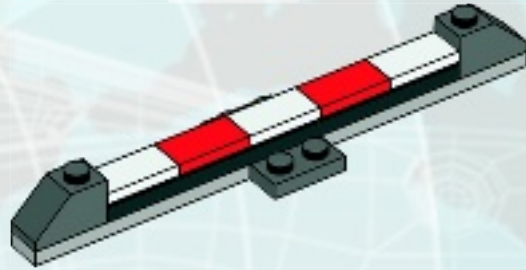

8

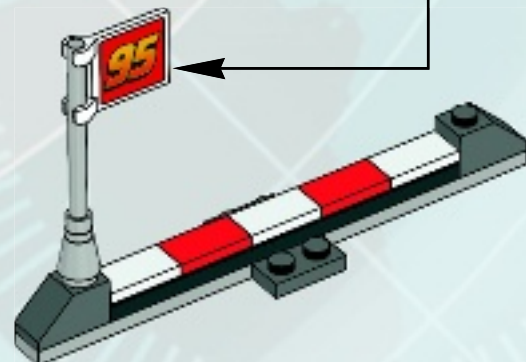

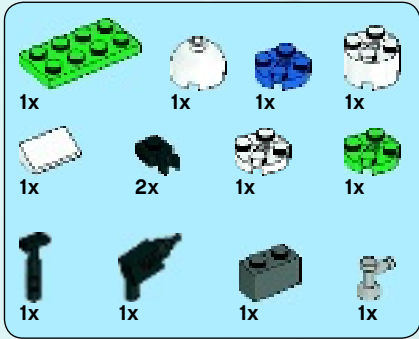

1

1

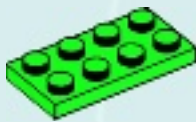

2



3



4



5

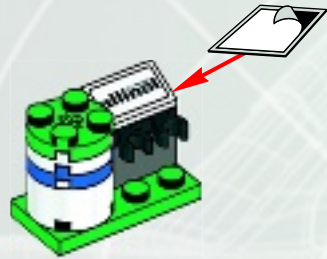

6



7



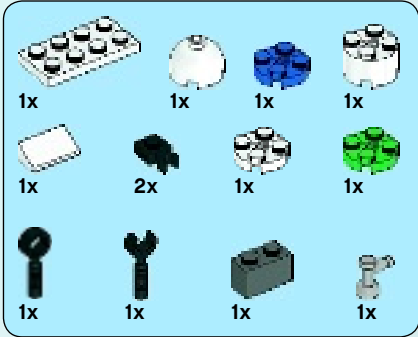

3

1



2

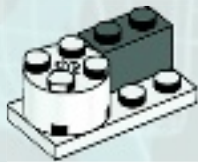

3

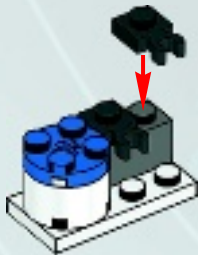

4



5

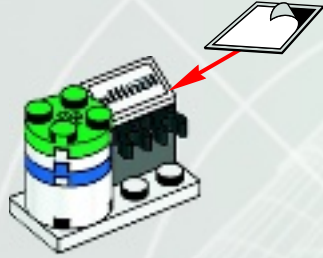

6



7



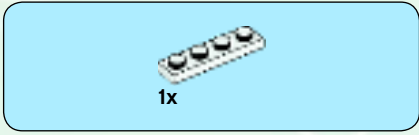
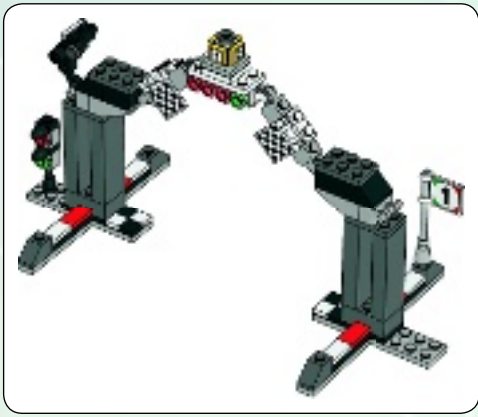

1



2

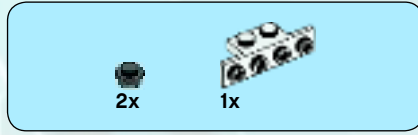
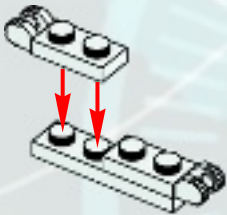

3

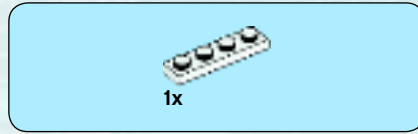
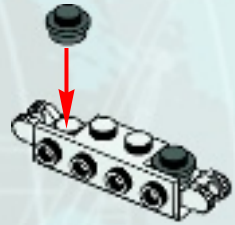

4

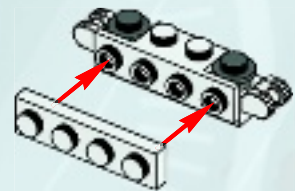

*target
acquired*

Waypoint 2

3x

1x

5

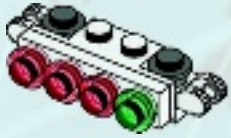

1x



1x

7

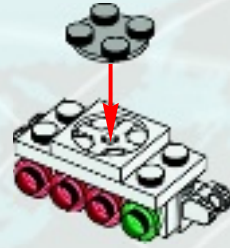

1x

6



1x

8

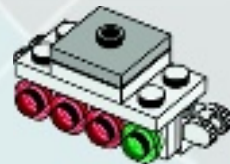



9

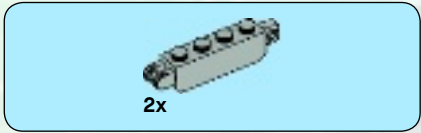
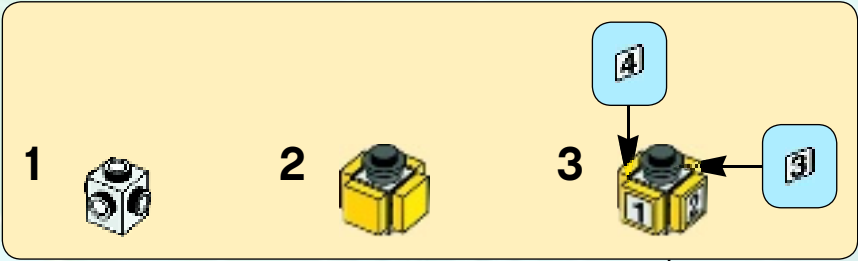

10

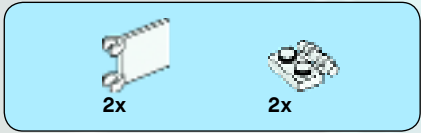
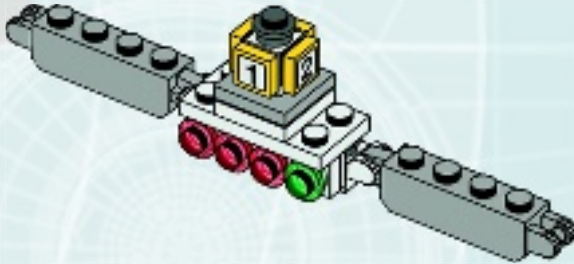

11

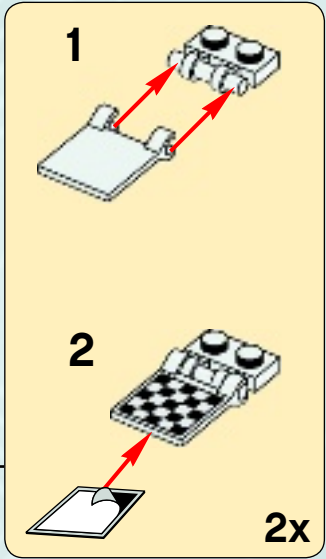

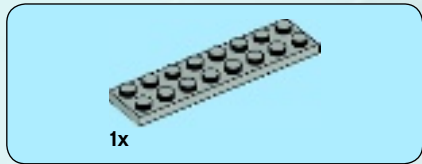
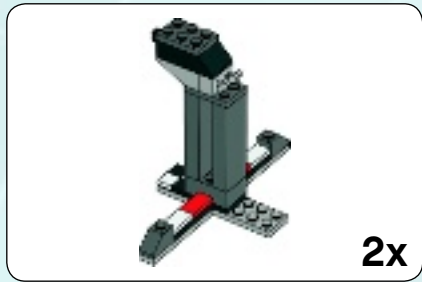

1

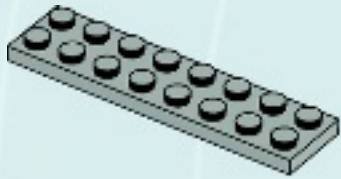

2

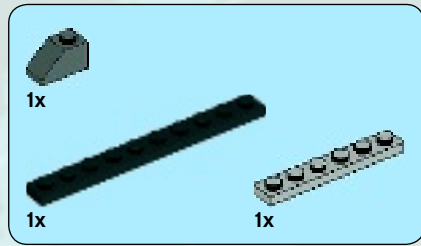

3

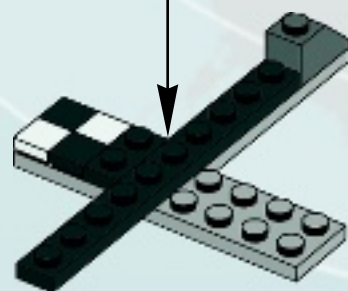
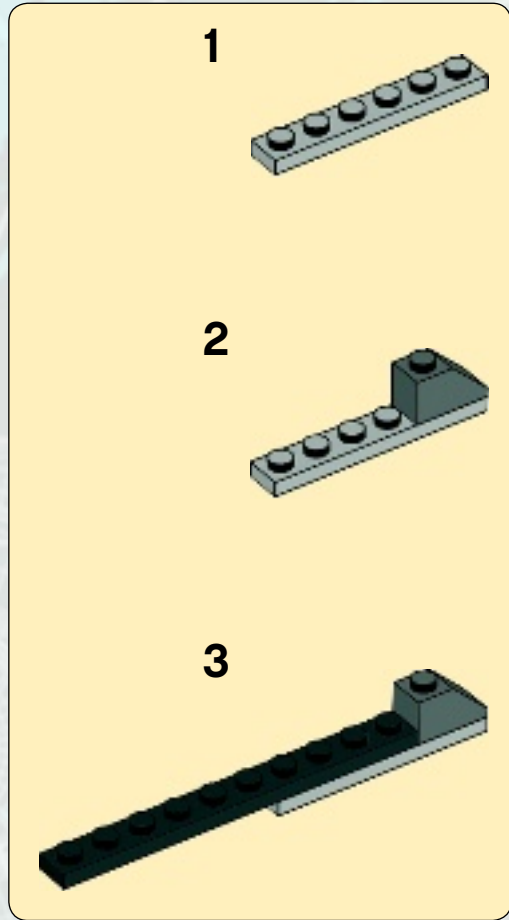

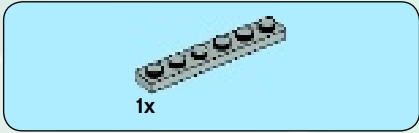

4

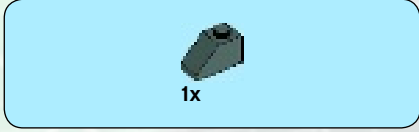
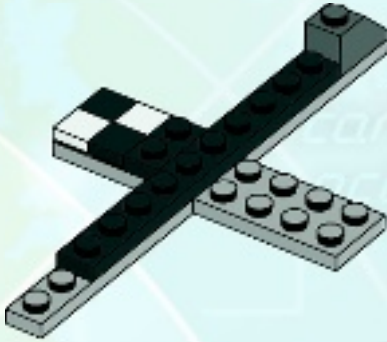

5

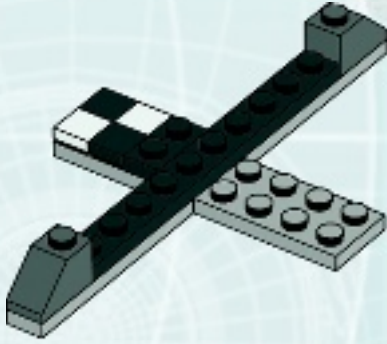

6

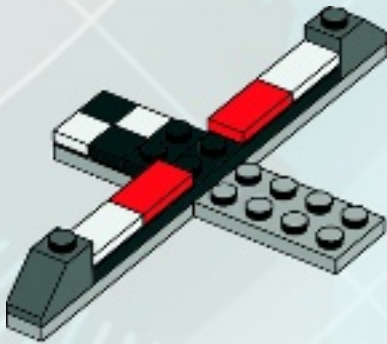



1x

7

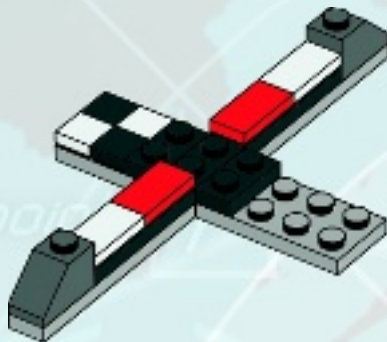

1x

8

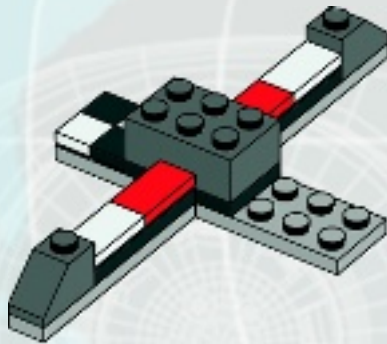

2x

9

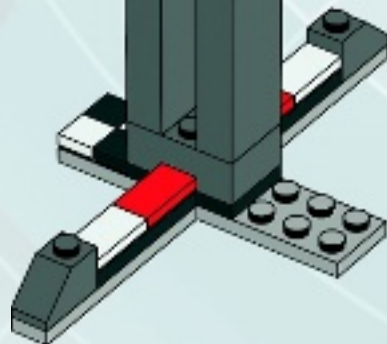

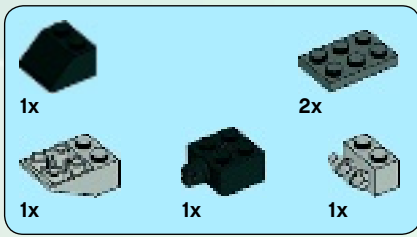

10

1



2

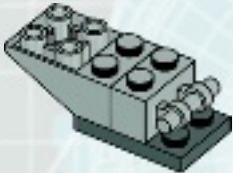

3



4

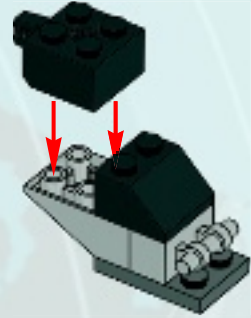

5

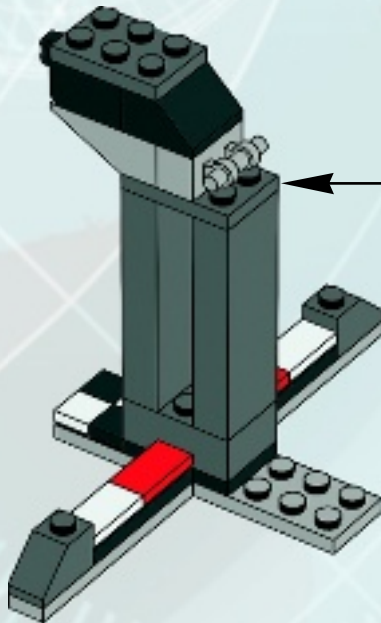
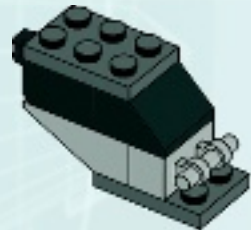

2x

waypoint 1



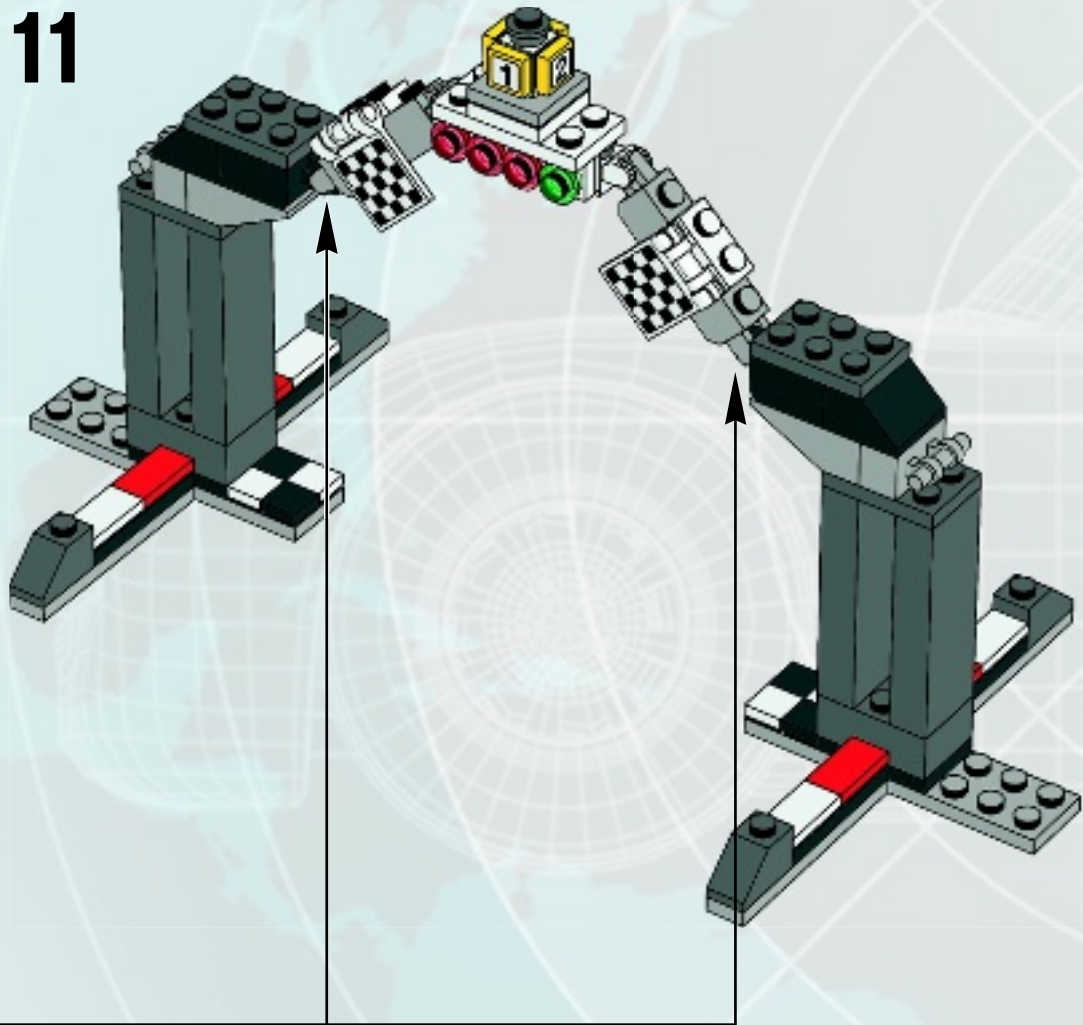

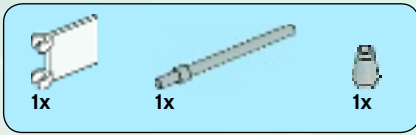
11



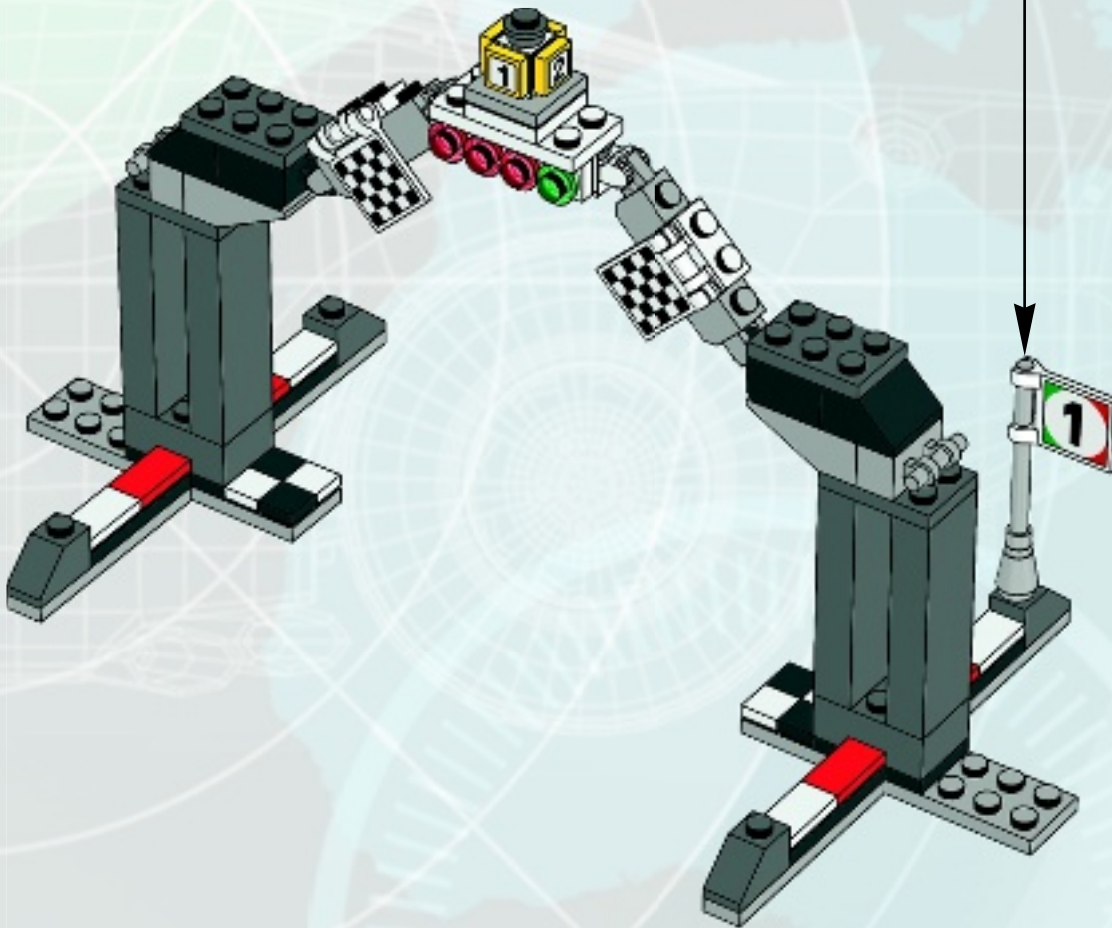
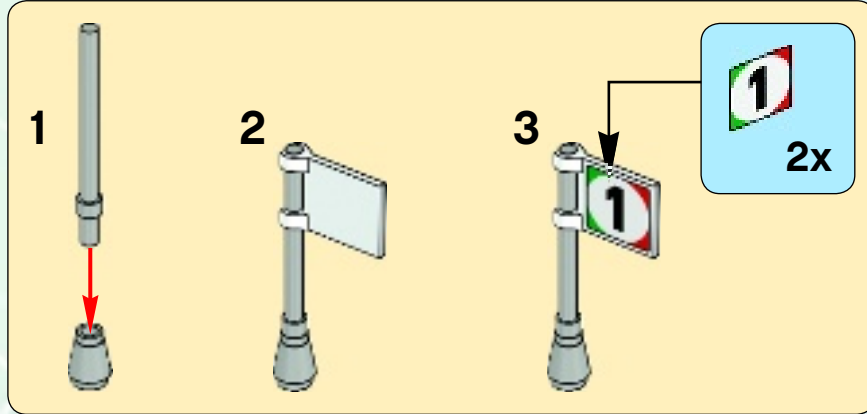

12



- 
1x
- 
1x
- 
2x
- 
2x
- 
1x

13

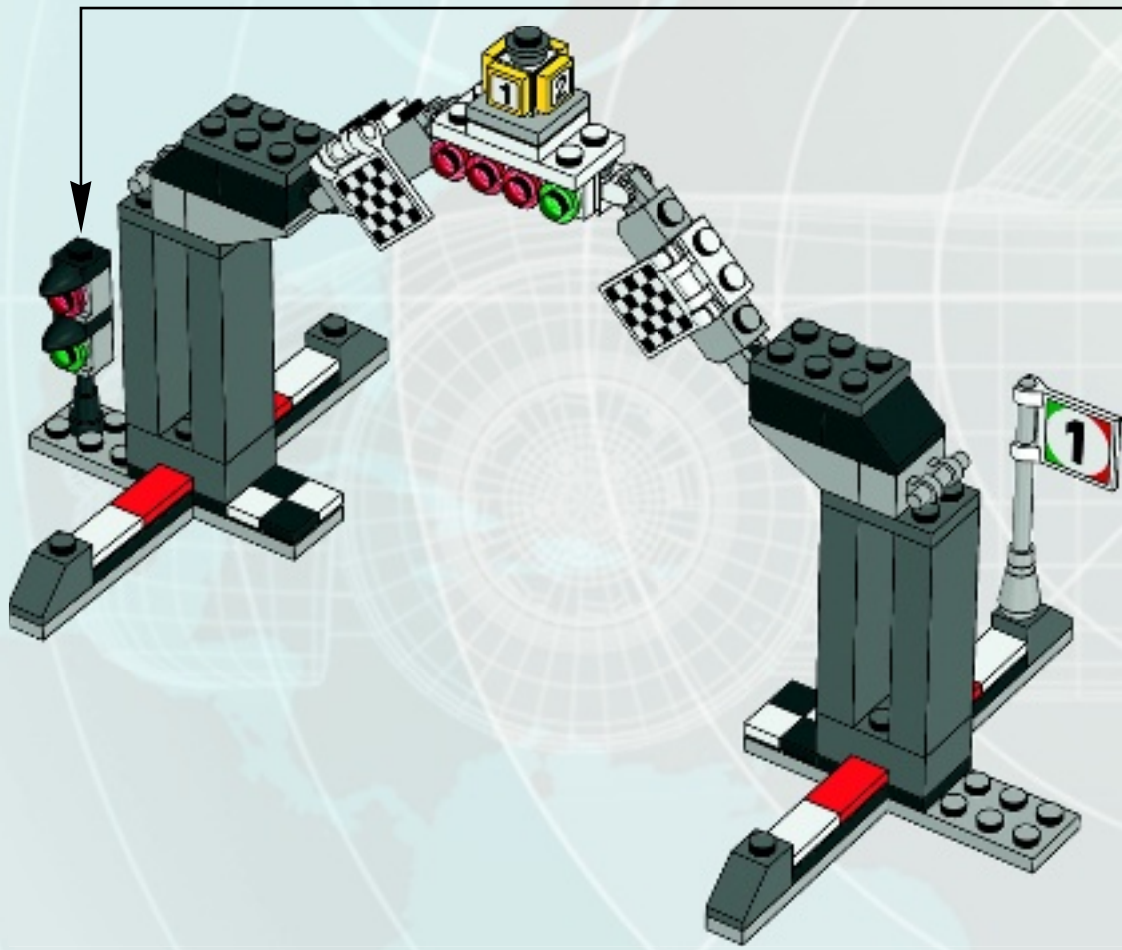



14

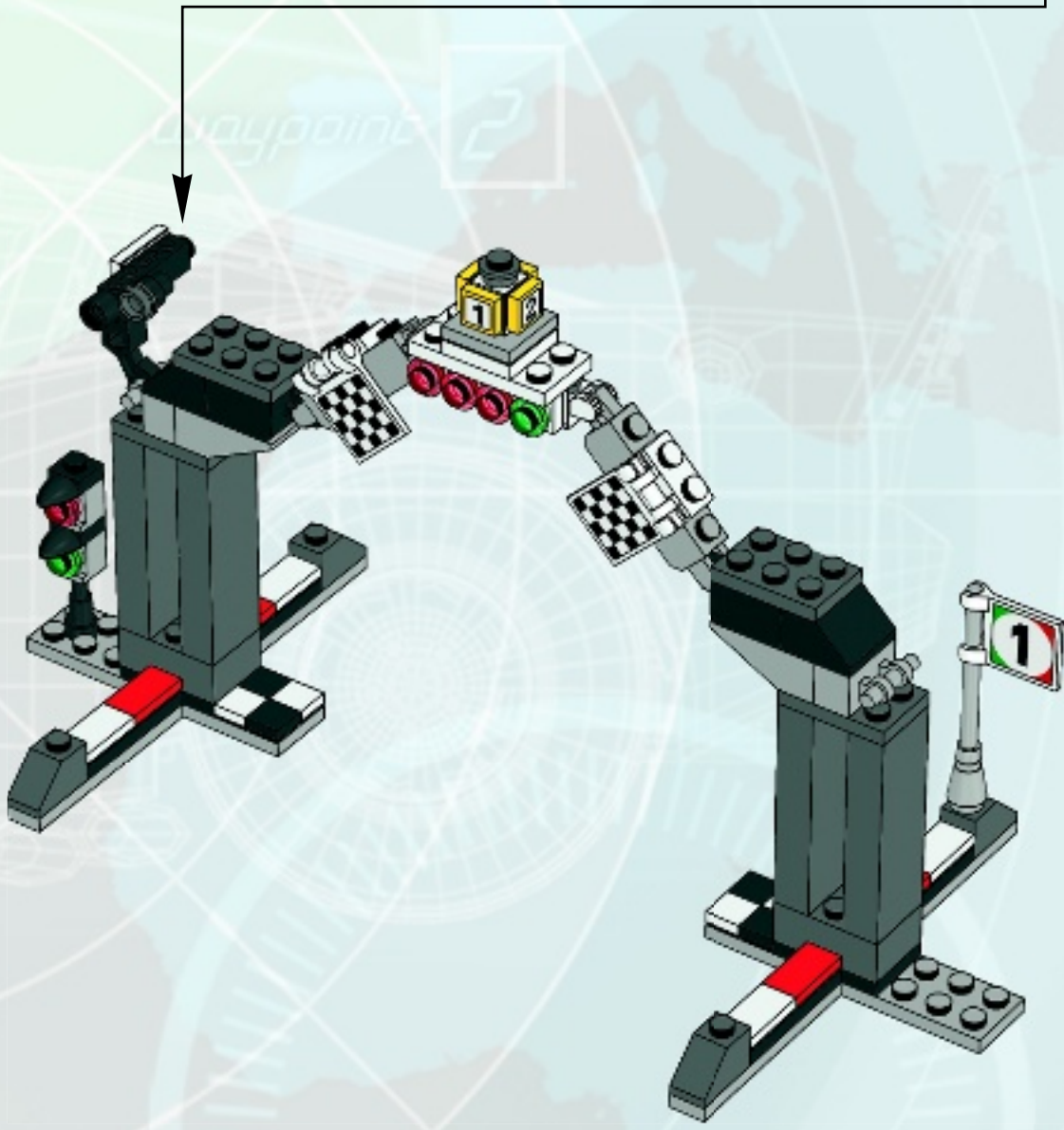
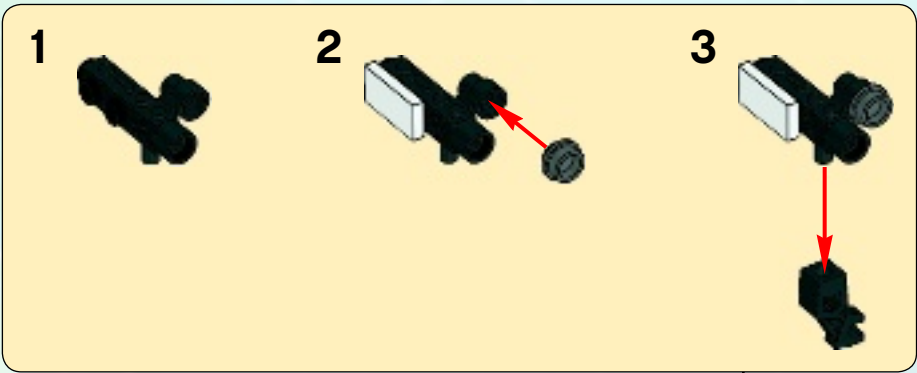







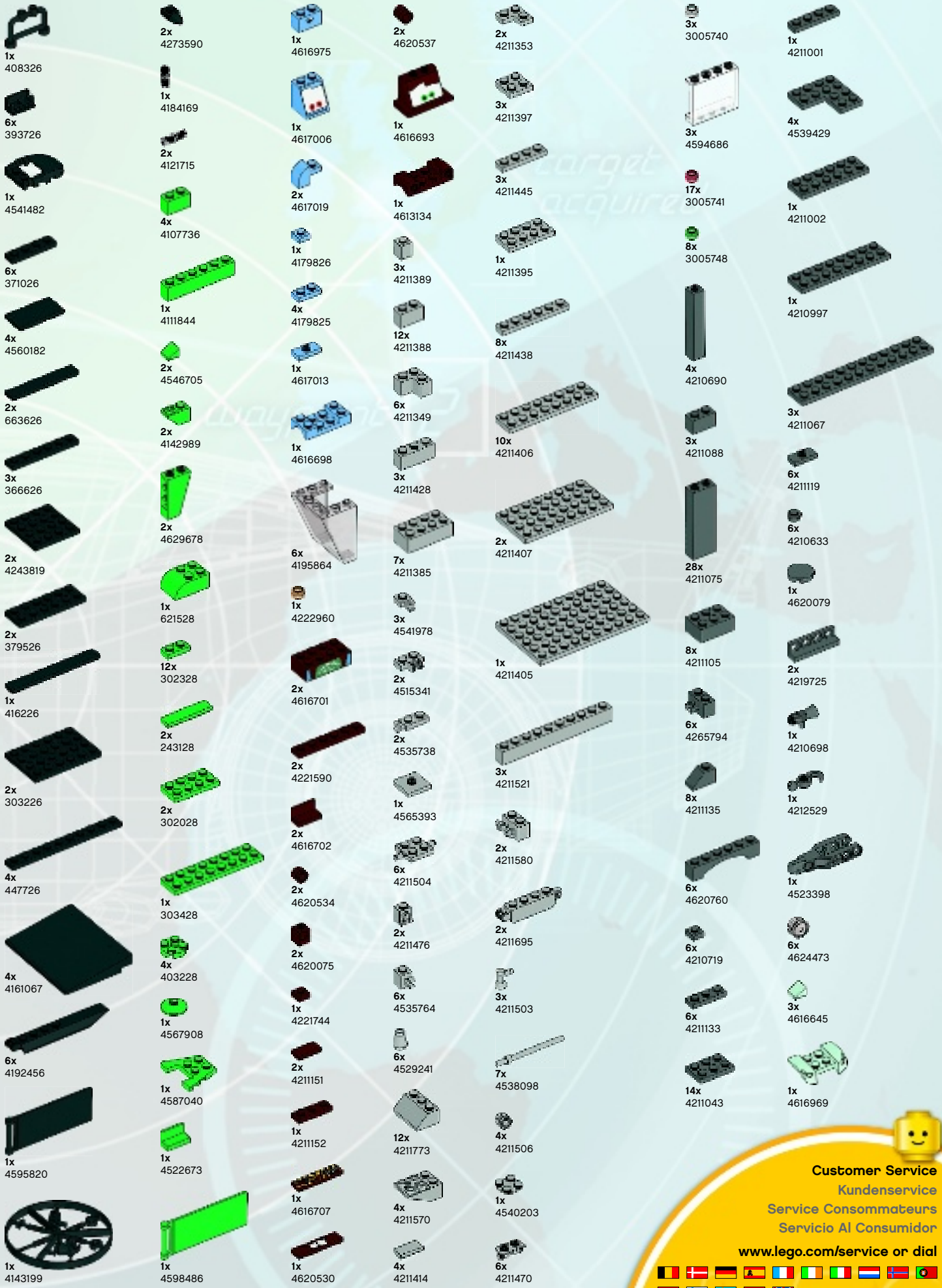

1x 408326
6x 393726
1x 4541482
6x 371026
4x 4560182
2x 663626
3x 366626
2x 4243819
2x 379526
1x 416226
2x 303226
4x 447726
4x 4161067
6x 4192456
1x 4595820
1x 4143199

2x 4273590
1x 4184169
2x 4121715
4x 4107736
1x 4111844
2x 4546705
2x 4142989
2x 4629678
1x 621528
12x 302328
2x 243128
2x 302028
1x 303428
4x 403228
1x 4567908
1x 4587040
1x 4522673
1x 4598486

1x 4616975
1x 4617006
2x 4617019
1x 4179826
4x 4179825
1x 4617013
1x 4616698
6x 4195864
1x 4222960
2x 4616701
2x 4221590
2x 4616702
2x 4620534
2x 4620075
1x 4221744
2x 4211151
1x 4211152
1x 4616707
1x 4620530

2x 4620537
1x 4616693
1x 4613134
3x 4211389
12x 4211388
6x 4211349
3x 4211428
7x 4211385
3x 4541978
2x 4515341
2x 4535738
1x 4565393
6x 4211504
2x 4211476
6x 4535764
6x 4529241
12x 4211773
4x 4211570
4x 4211414

2x 4211353
3x 4211397
3x 4211445
1x 4211395
8x 4211438
10x 4211406
2x 4211407
1x 4211405
3x 4211521
2x 4211580
2x 4211695
3x 4211503
7x 4538098
4x 4211506
1x 4540203
6x 4211470

3x 3005740
3x 4594686
17x 3005741
8x 3005748
4x 4210690
3x 4211088
28x 4211075
8x 4211105
6x 4265794
8x 4211135
6x 4620760
6x 4210719
6x 4211133
14x 4211043

1x 4211001
4x 4539429
1x 4211002
1x 4210997
3x 4211067
6x 4211119
6x 4210633
1x 4620079
2x 4219725
1x 4210698
1x 4212529
1x 4523398
6x 4624473
3x 4616645
1x 4616969



Customer Service
Kundenservice
Service Consommateurs
Servicio Al Consumidor

www.lego.com/service or dial



: 00800 5346 5555
: 1-800-422-5346



8486



8200, 8487



8423, 8639



8638



8639



8424



8639



8638



8426



8201, 8487



8424



8638



8639



8426, 8639



8638



8487



8487



8638



8206



8639



8639



8487



8426



8638



8423



8486



8487



8206, 8484



WIN!

Go to www.LEGOsurvey.com/product to fill out a survey for a chance to win a cool LEGO® Product. No purchase necessary. Open to all residents where not prohibited.

 www.LEGO.com



www.LEGOsurvey.com/product

GEWINNE!

Nimm an der Umfrage auf www.LEGOsurvey.com/product teil und hab die Chance ein cooles LEGO® Produkt zu gewinnen!
Die Teilnahme am Gewinnspiel führt zu keinerlei Kaufverpflichtungen. Teilnahme in allen nicht ausgeschlossenen Ländern möglich.

WIN!

Ga naar www.LEGOsurvey.com/product, vul een enquêteformulier in en maak kans op een cool LEGO® product.
Geen aankoopverplichting. Iedereen mag deelnemen, uitgezonderd ingezetenden van landen waar een enquêteverbod geldt.

GAGNE !

Visite www.LEGOsurvey.com/product pour répondre à un questionnaire et avoir une chance de gagner un produit LEGO® très cool !
Aucune obligation d'achat. Ouvert à tous les résidents des pays autorisés.

当てよう!

www.LEGOsurvey.com/product アンケートにご記入ください。当選者にはレゴ®製品を差し上げます。にアクセスして、お買い上げの必要はありません。禁止されていない限り、すべての皆様にご利用いただけます。