



Camaro Z/28
1969





We've got a mean streak.

Z/28 Camaro.

The '69 Z/28. So ominous it goes by its code name. Code name: Z/28. Standard equipment: mechan-

ical lifters, high-performance cam and an aluminum intake manifold under a massive Holley 4-barrel. Underneath, multi-leaf rear

for the 4-speed. To complete the setup, just add the new "Vette-type 4-wheel power disc brakes.

By now you know the mean streak isn't just painted on—it's built in. One more thing. People are

bound to ask what the Z stands for. Tell them "Zaps!" **Putting you first, keeps us first.**

IL COUPÉ SPORTIVO

Abbordabili, sportive ed eleganti, le "Pony Car" hanno rivoluzionato l'industria automobilistica quando furono lanciate per la prima volta a metà degli anni '60. Una nuova e più giovane generazione di appassionati di auto fu immediatamente attratta dalle linee aerodinamiche delle vetture, dotate di lunghi cofani e potenti motori. Sebbene quasi tutte le case automobilistiche abbiano poi introdotto la propria interpretazione dell'auto pony, pochi modelli hanno avuto lo stesso successo della Chevrolet Camaro.



The skier's skier with the Camaro's Camaro.



There are skiers. And then there are skiers. Jean-Claude Killy is one of the latter.

The Camaro Z/28 is a special breed, too.

It comes poised on a beefed-up suspension and special road-grabbing wide oval tires.

Under that striped hood is a tough 302 V8 that inhales through a big Holley 4-barrel and exhales through dual exhausts.

Z/28

Add four-on-the-floor with a Hurst shifter plus 4-wheel power disc brakes and you've got the closest thing to a 'Vette yet. Z/28. In our Sports Department. Almost as much fun as skiing.



Putting you first, keeps us first.

See Olympic Gold Medalist Jean-Claude Killy, Sundays, CBS-TV. Check your local TV listings.

69 CH-43 A
Ski February
February
1 page-4 colors
A P 7729-11 21 68-5



UN SUCCESSO STREPITOSO

La Chevrolet Camaro Z28 di seconda generazione rimane l'essenza della perfetta Muscle Car. Lanciata nel 1969, era dotata del caratteristico cofano a cupola a induzione e di "speed line" stampate sui paraurti e sulle portiere, che le conferivano un look originale e distintivo. Non assomigliava a nessun'altra auto dell'epoca e, a oltre 50 anni di distanza, lo styling risulta ancora audace, fresco e inconfondibile.



camaro

Camaro

CAMARO



UN'ICONA DEL MONDO DEI MOTORI

Nonostante siano trascorsi 55 anni dal lancio della prima Chevrolet Camaro, questo famoso marchio è ancora molto vivo e rilevante, con la sesta generazione della vettura ancora in produzione oggi. Sono un brand e un nome che continuano a richiamare appassionati di generazioni diverse, amatissimi dai fan delle Muscle Car e presente in innumerevoli videogiochi, programmi TV, film e cultura pop.

CAMARO

CAMARO





IL DESIGN TEAM

"Sono cresciuto con una forte passione per le auto e ho iniziato a sfogliare riviste di motori sin dalla tenera età e quindi poter lavorare a questo modello LEGO® con i veri designer di automobili Chevrolet è stato davvero un sogno diventato realtà. Non solo abbiamo voluto riprodurre lo styling generale della vettura, ma anche aggiungere i dettagli più divertenti, e tuttavia essenziali, come le portiere e lo sterzo funzionanti. È stato anche fantastico poter offrire alcune opzioni di personalizzazione, proprio come era possibile fare con la Camaro originale in passato".

Sven Franic, LEGO® Designer



IL TUO MODELLO. LA TUA SCELTA.

Una delle caratteristiche più apprezzate della Camaro originale era l'ampia gamma di opzioni di personalizzazione e di motori ad alte prestazioni disponibile. Allo stesso modo, sta a te decidere come stilizzare la tua versione LEGO® dell'auto: vuoi un Coupé dal tetto rigido o una bella decappottabile? E le strisce? Bianche classiche, grigie eleganti o rosse fiammegianti? Ci sono anche coperture opzionali per i fari e due targhe tra cui scegliere.



I tre modelli non possono essere costruiti simultaneamente.

Le istruzioni per questi modelli alternativi sono disponibili online all'indirizzo: [LEGO.com/buildinginstructions](https://www.lego.com/buildinginstructions)



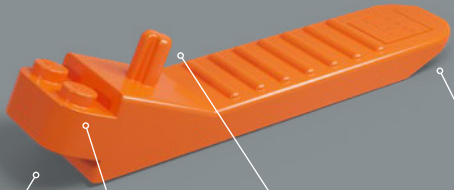
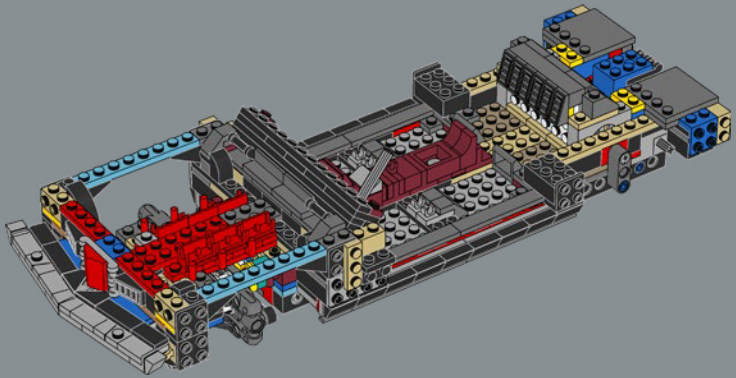
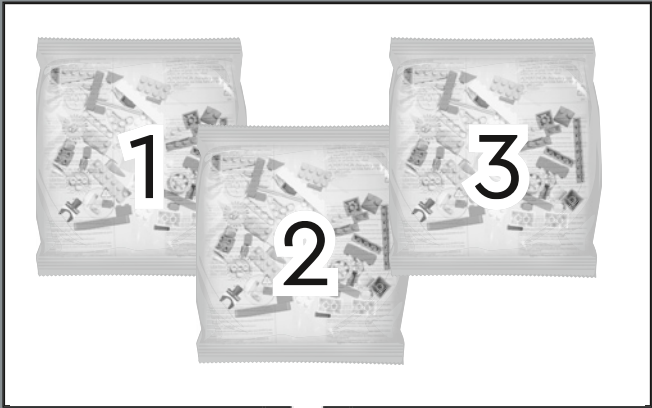

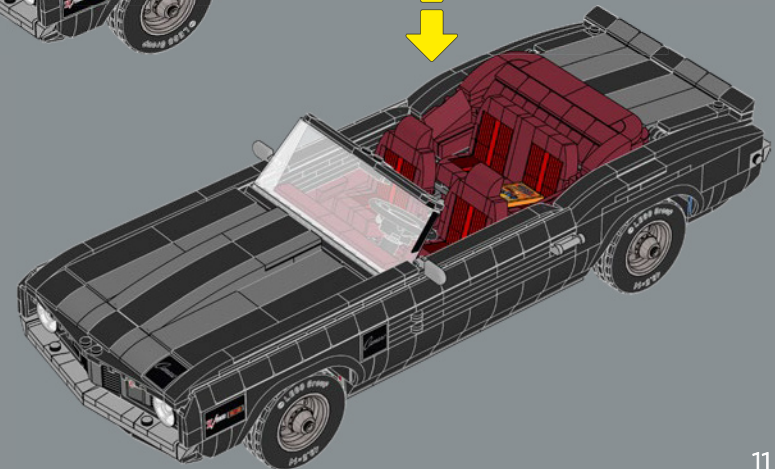
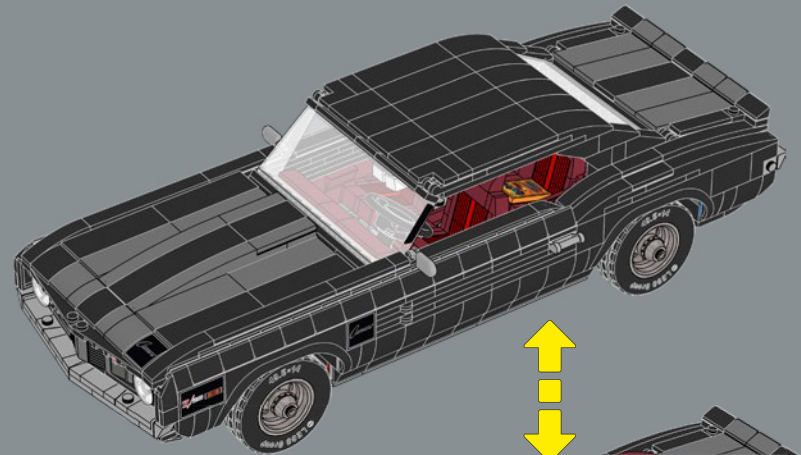
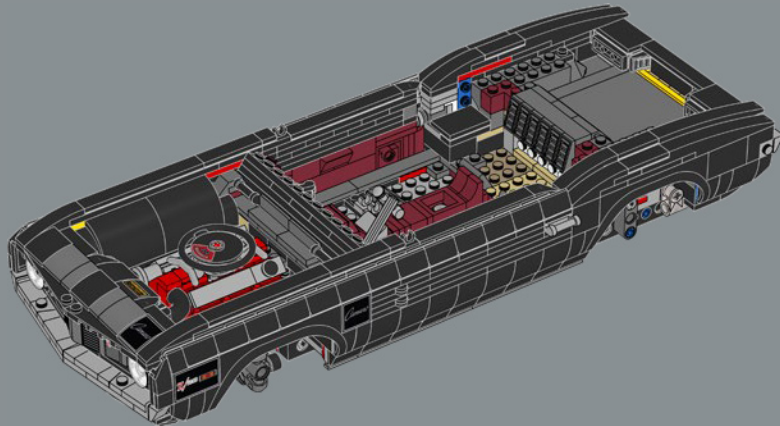
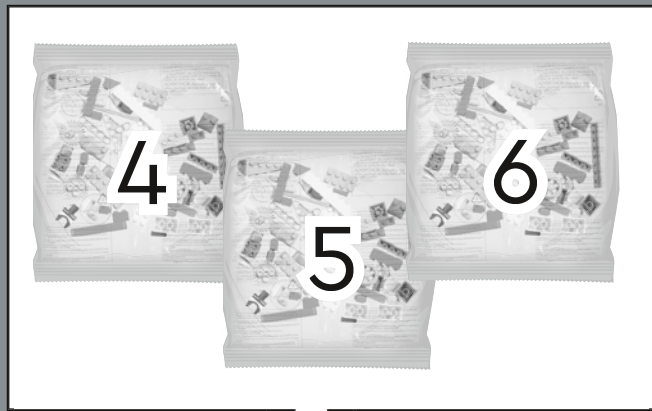

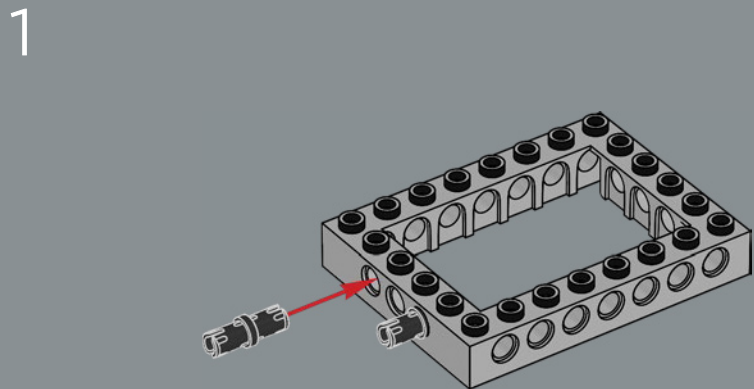
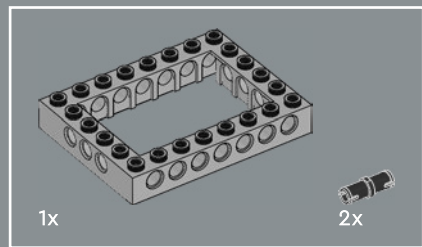

2

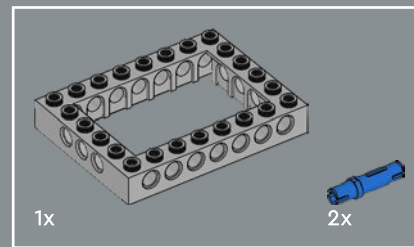
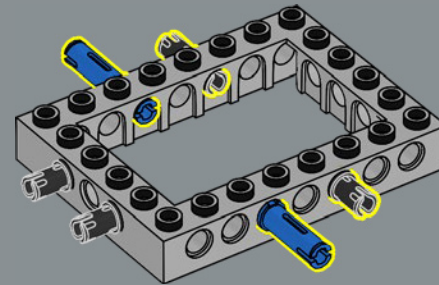

3

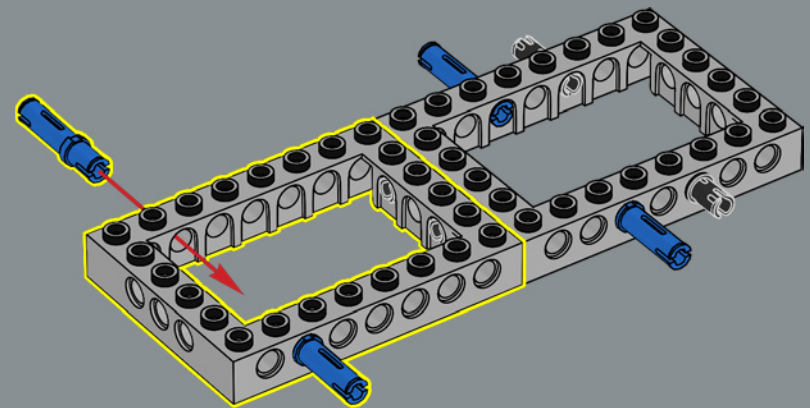

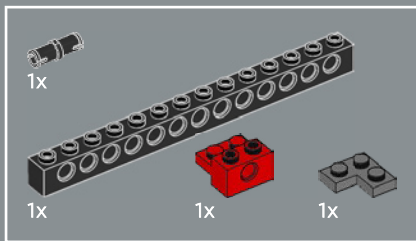

4

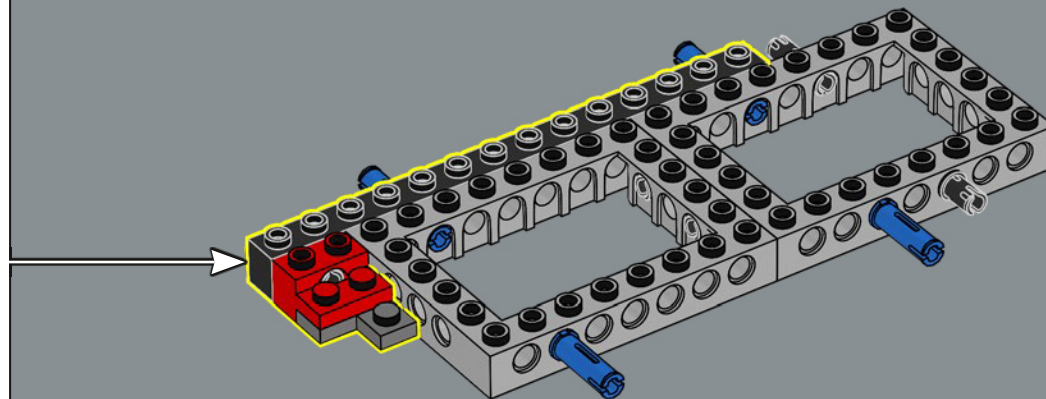
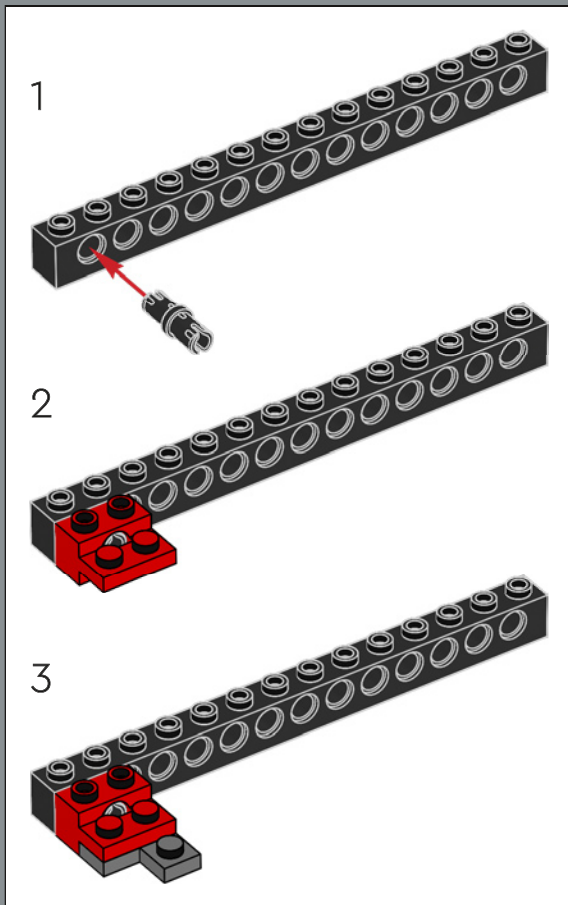

Il nome Camaro riprende la tradizione di Chevrolet di denominare i modelli con la lettera "C" come iniziale (Corvaire, Corvette, Chevelle, ecc.).

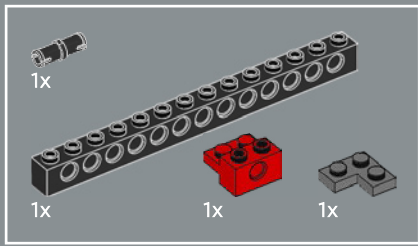

5

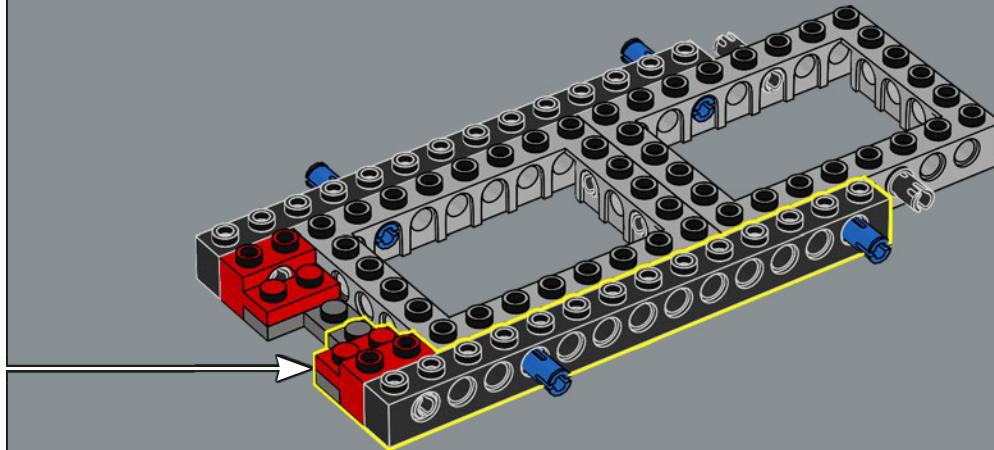
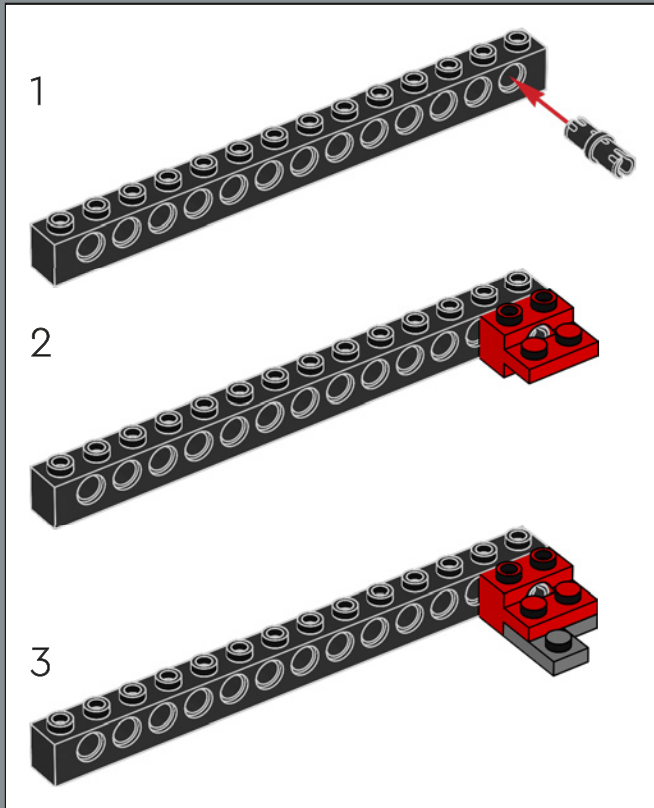

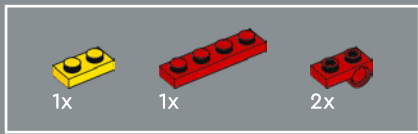

6

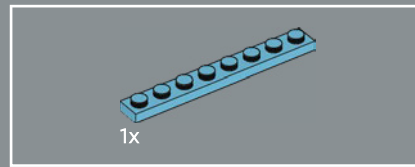
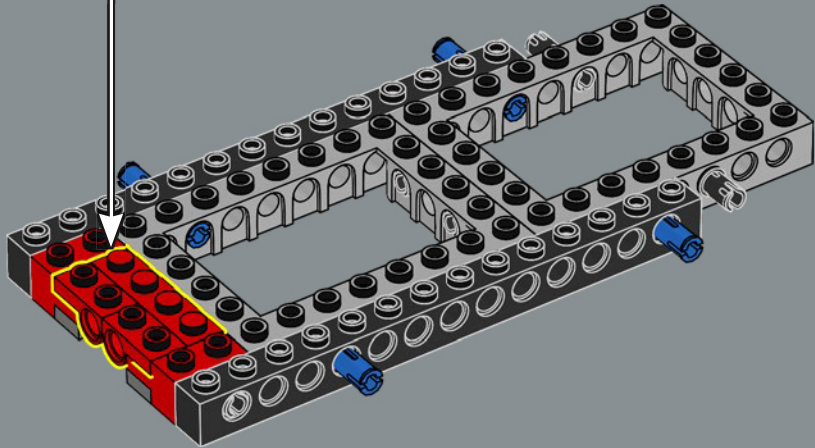
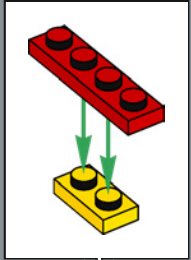

7

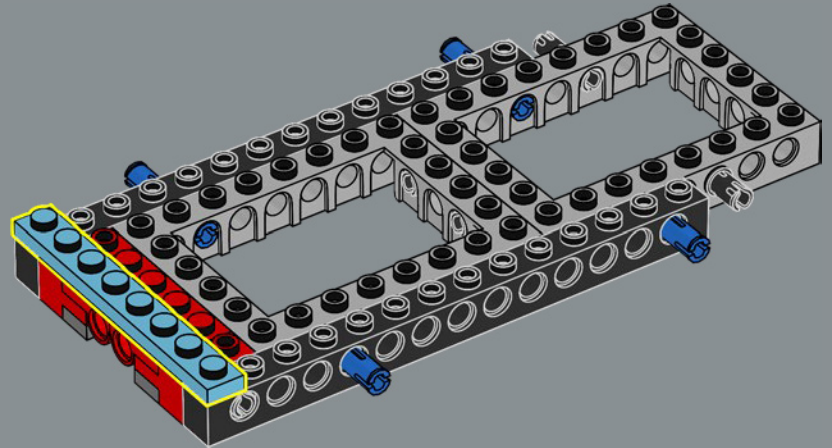

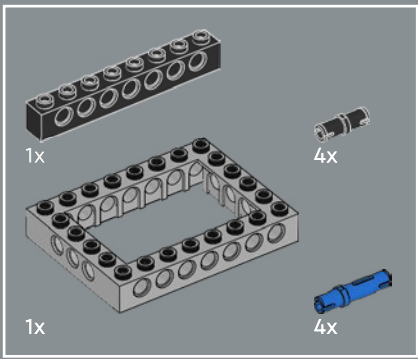

8

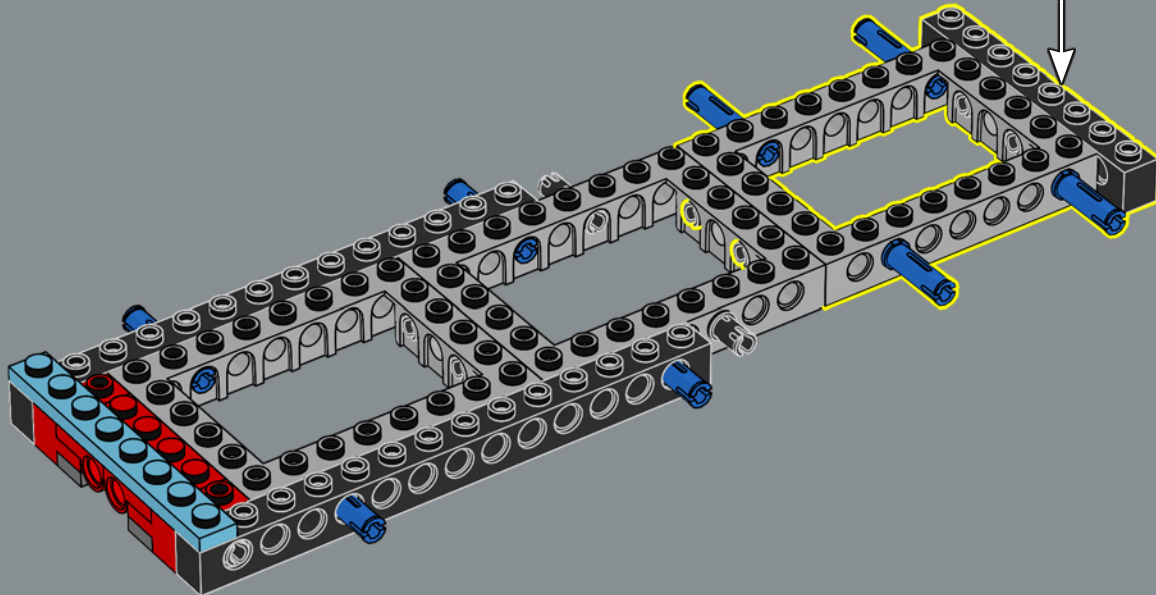
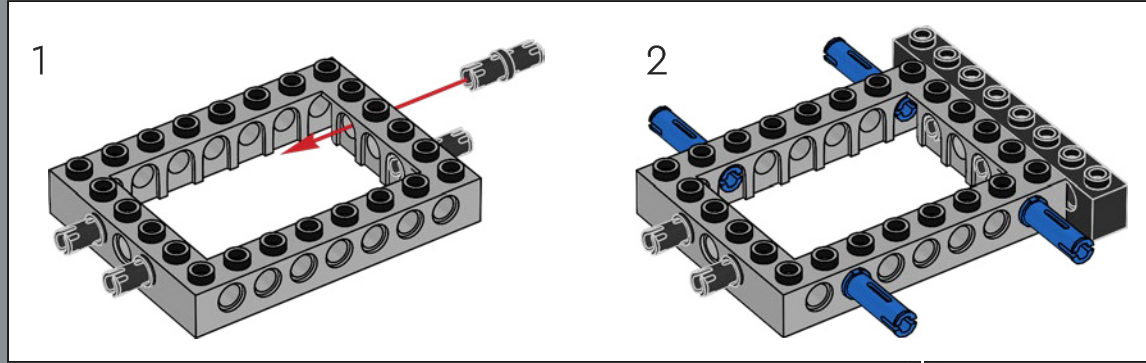

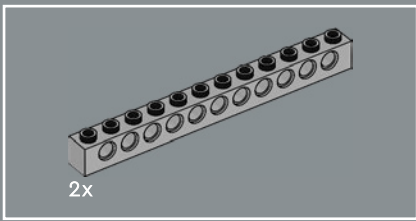

9

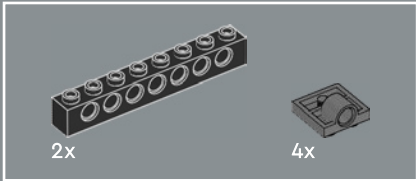
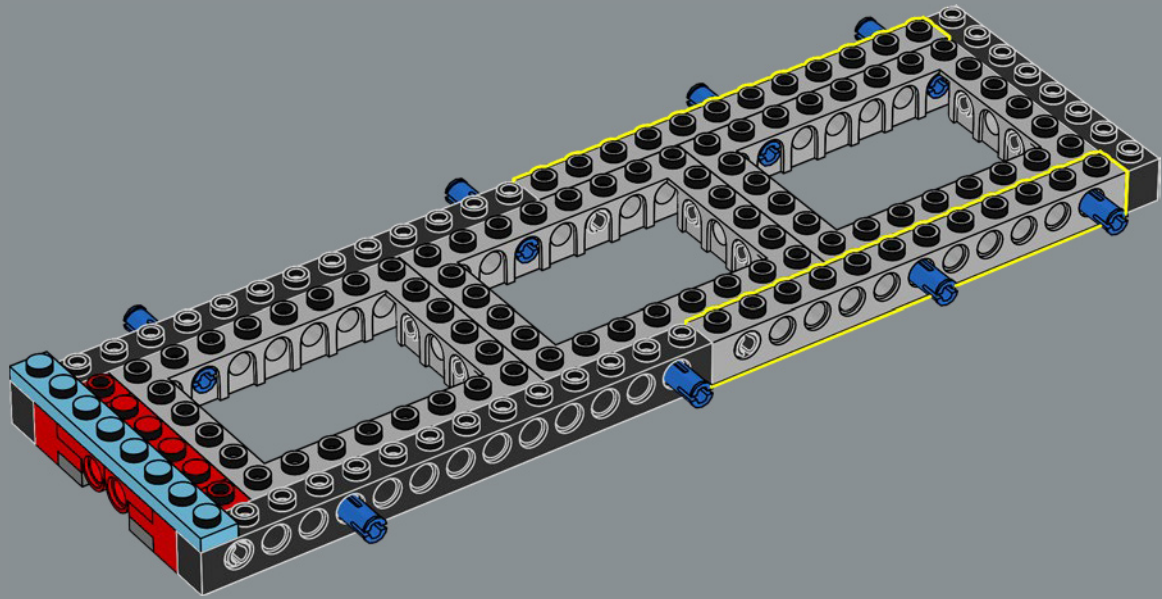

10

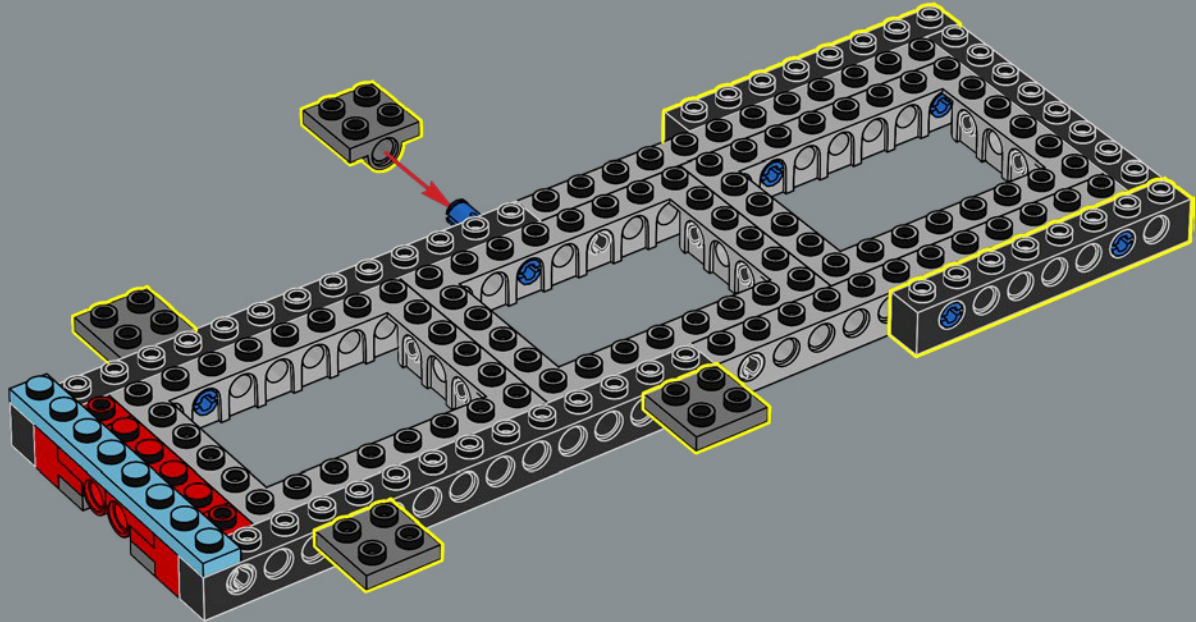

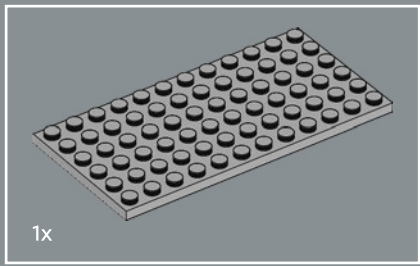

1x

11

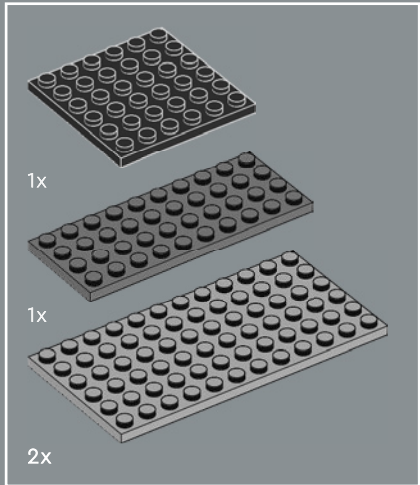
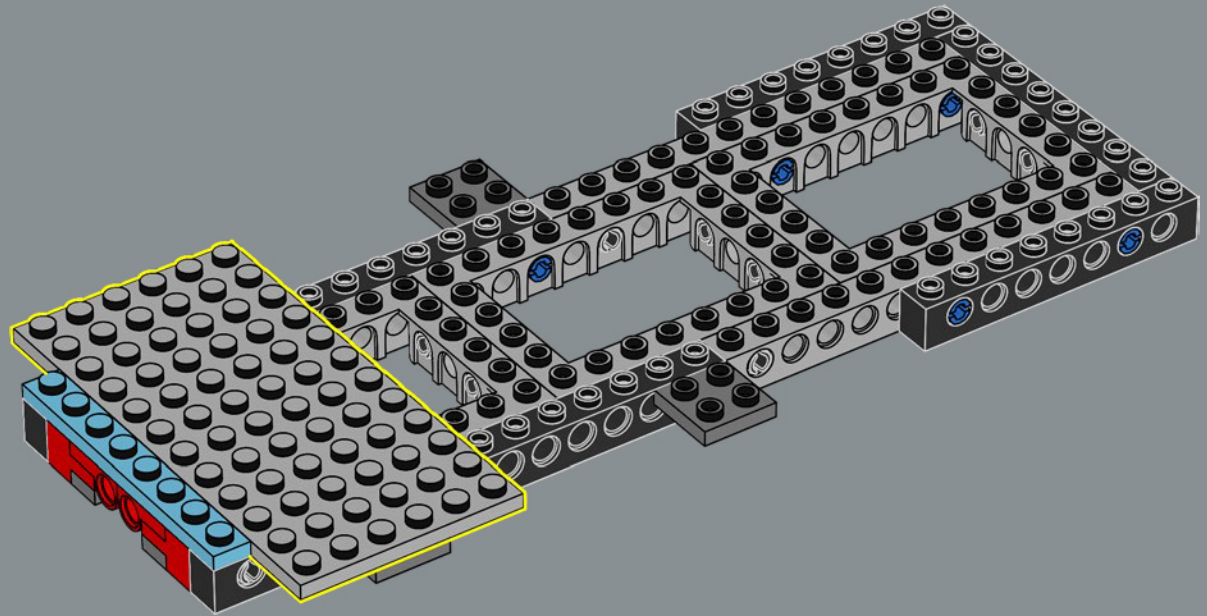

1x

1x

2x

12

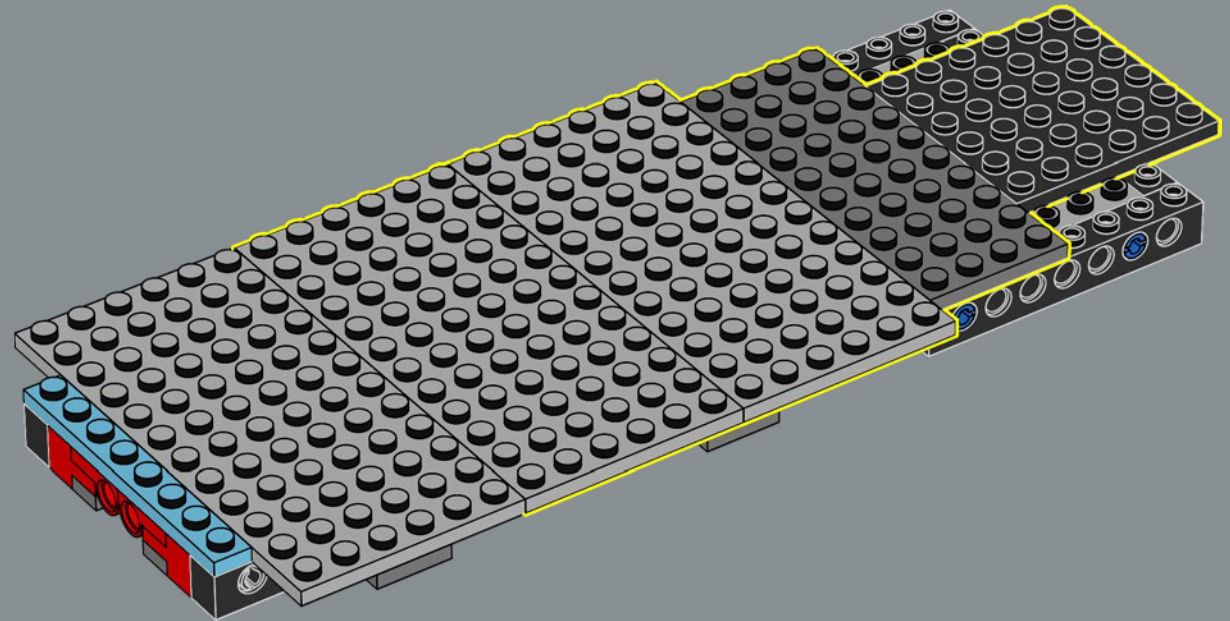



13

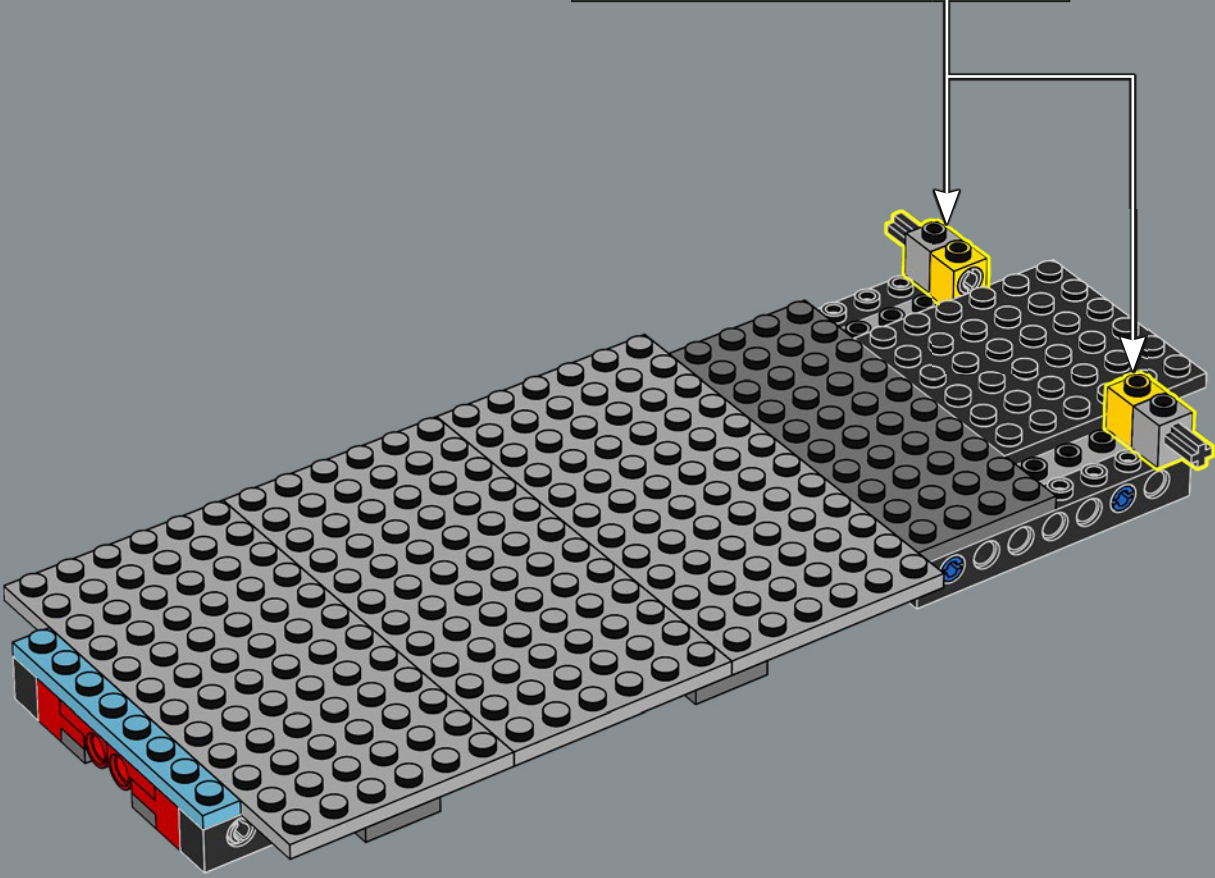
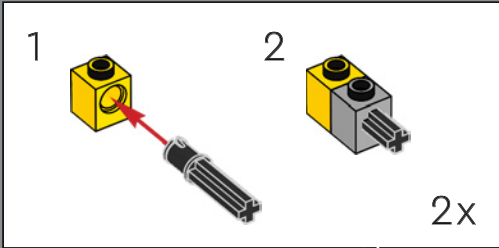

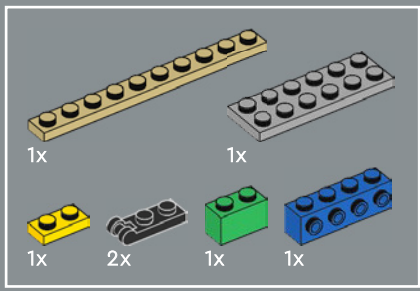

14

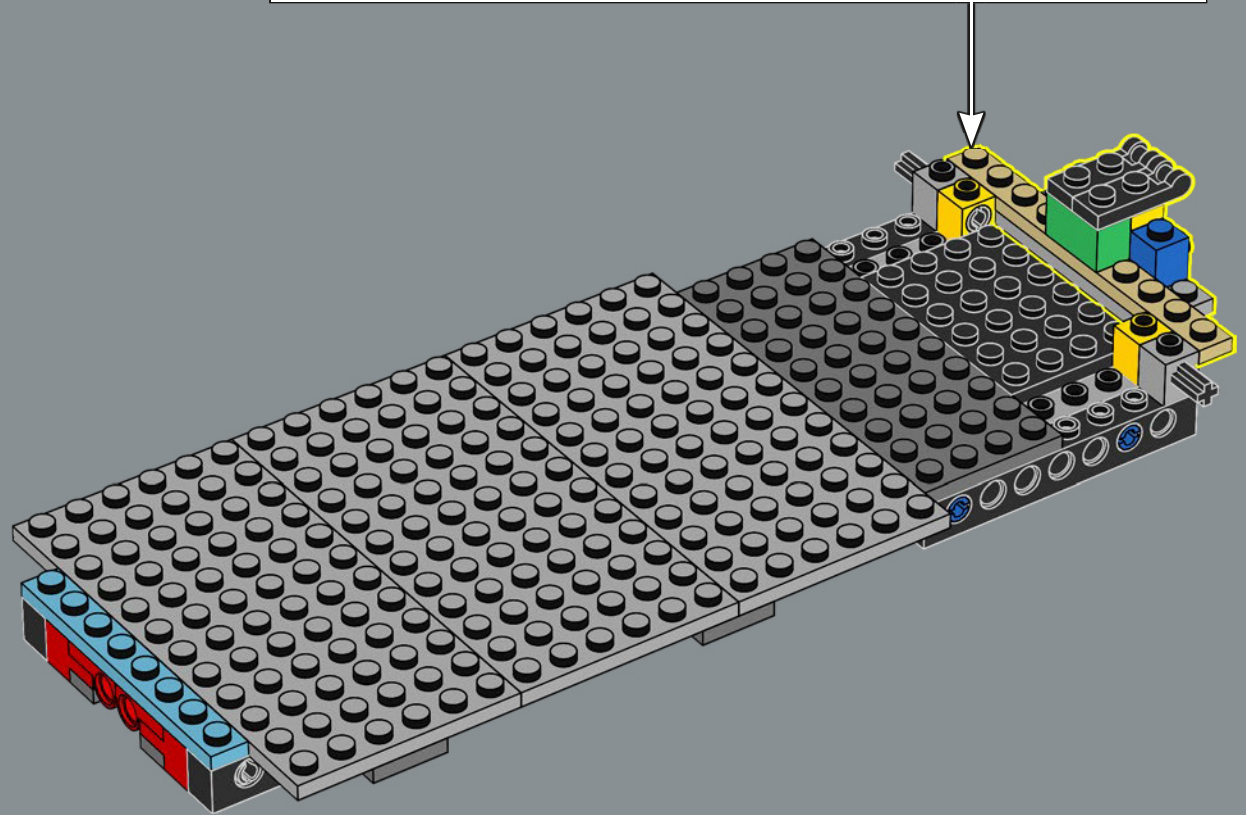
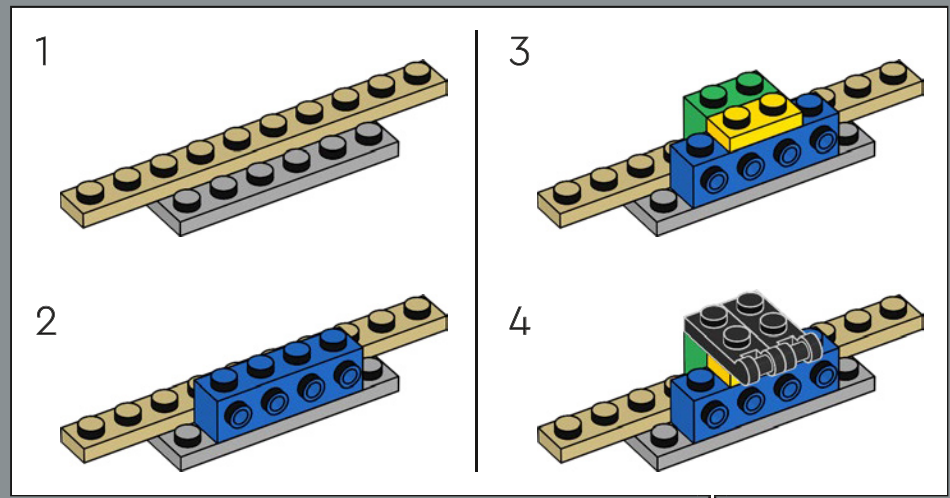

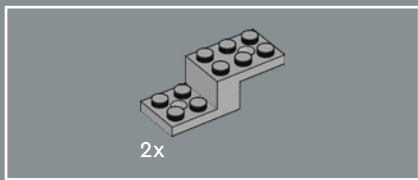

15

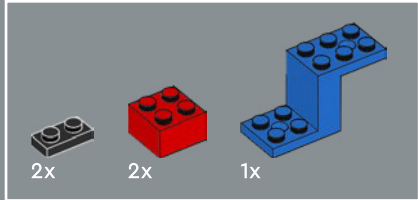
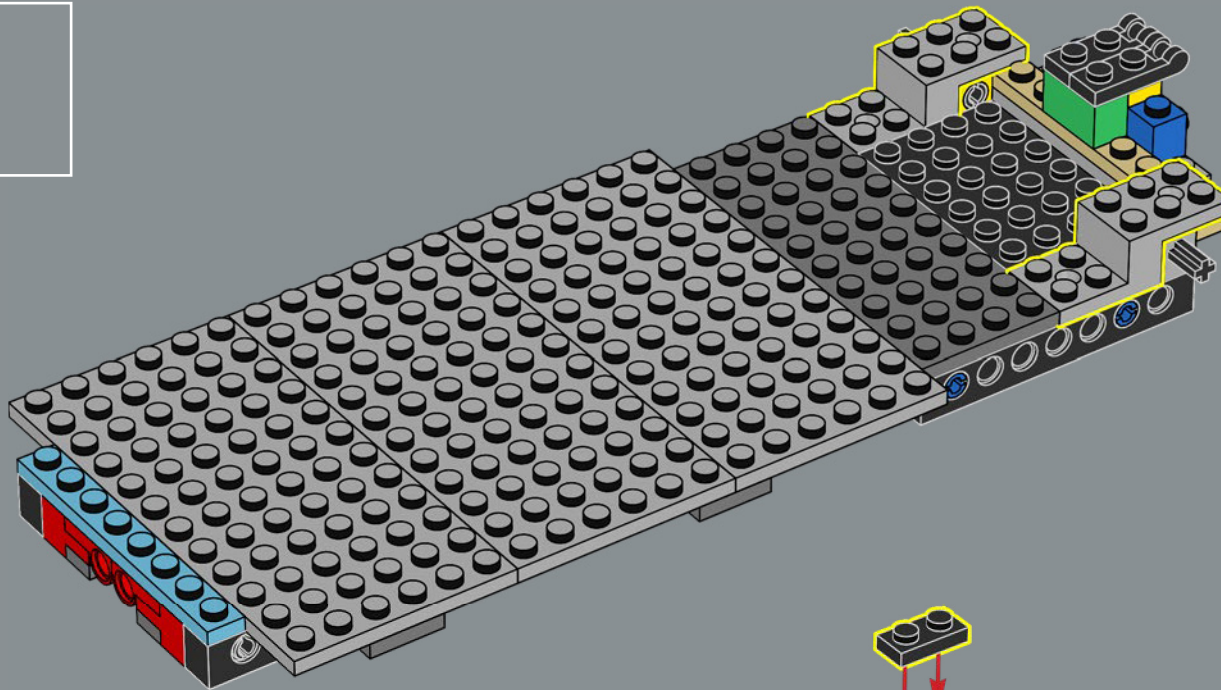

16

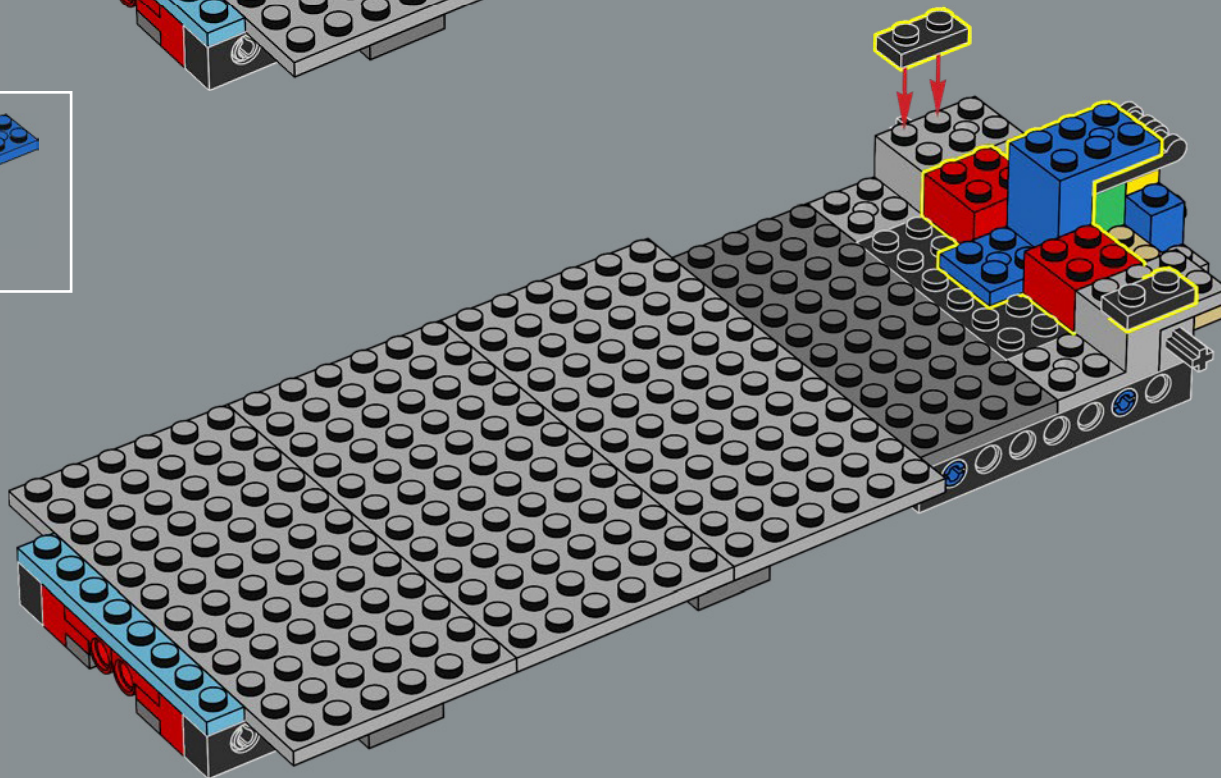

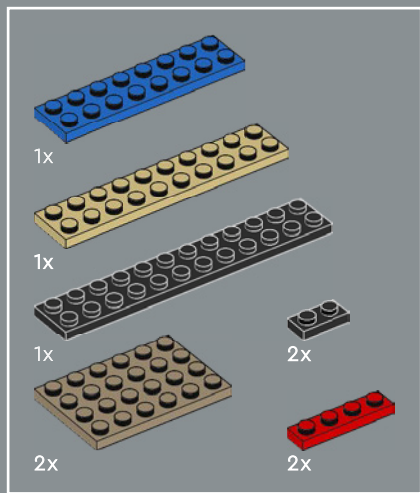

17

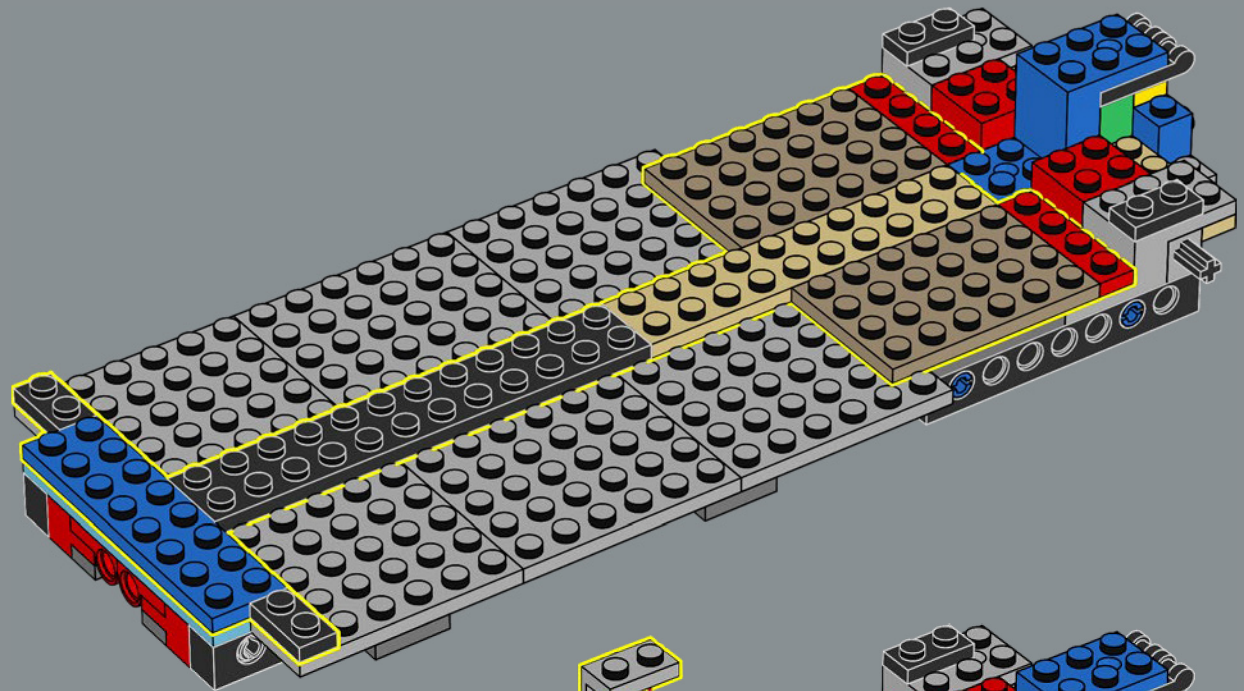

18

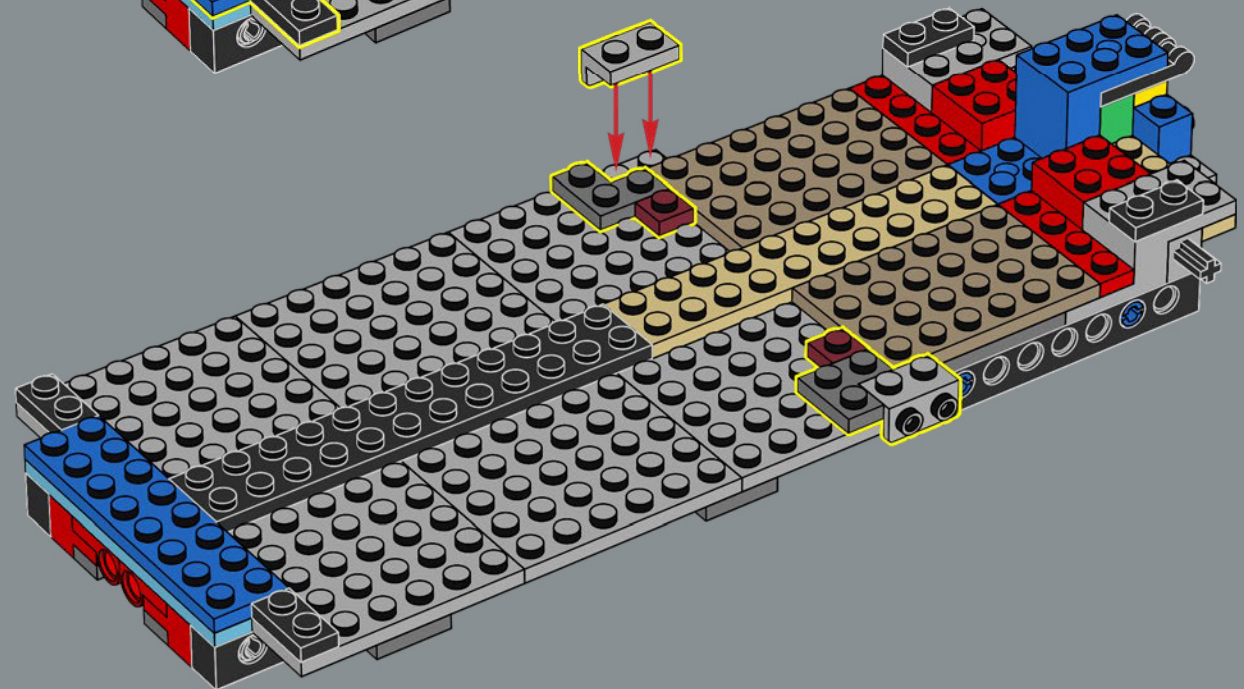

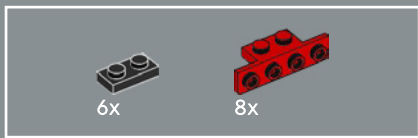

19

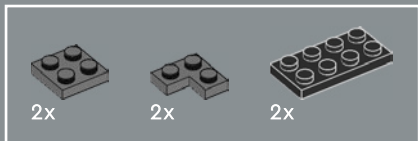
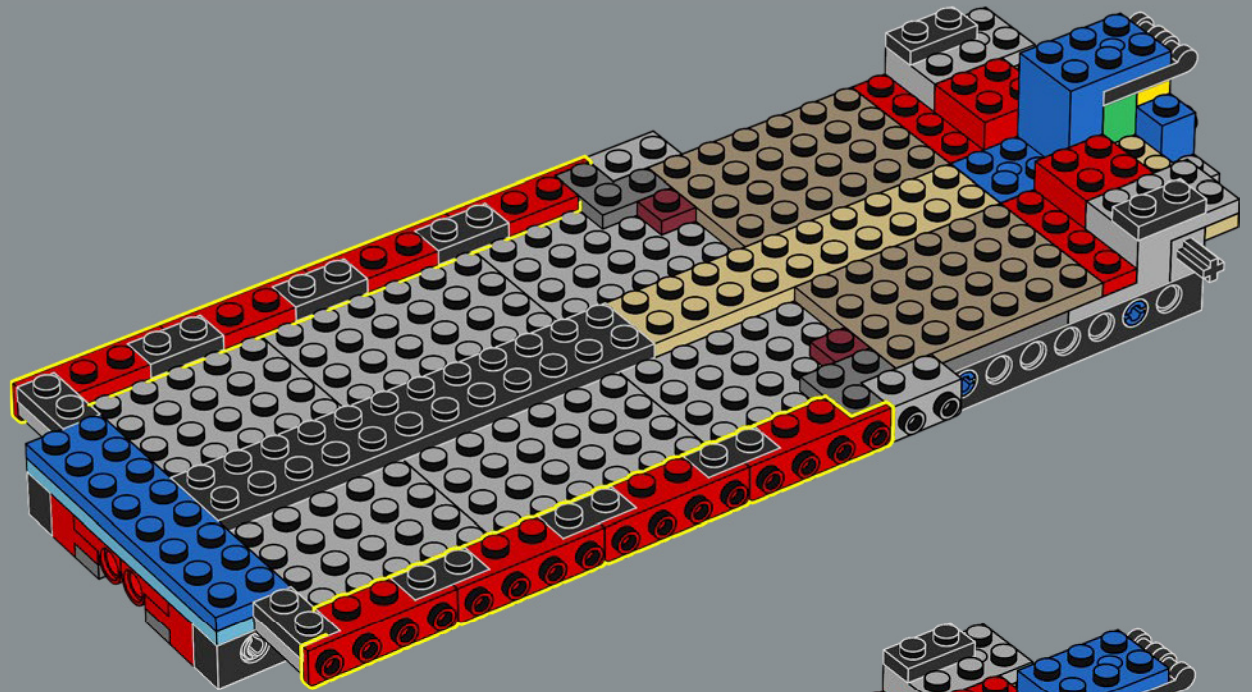

20

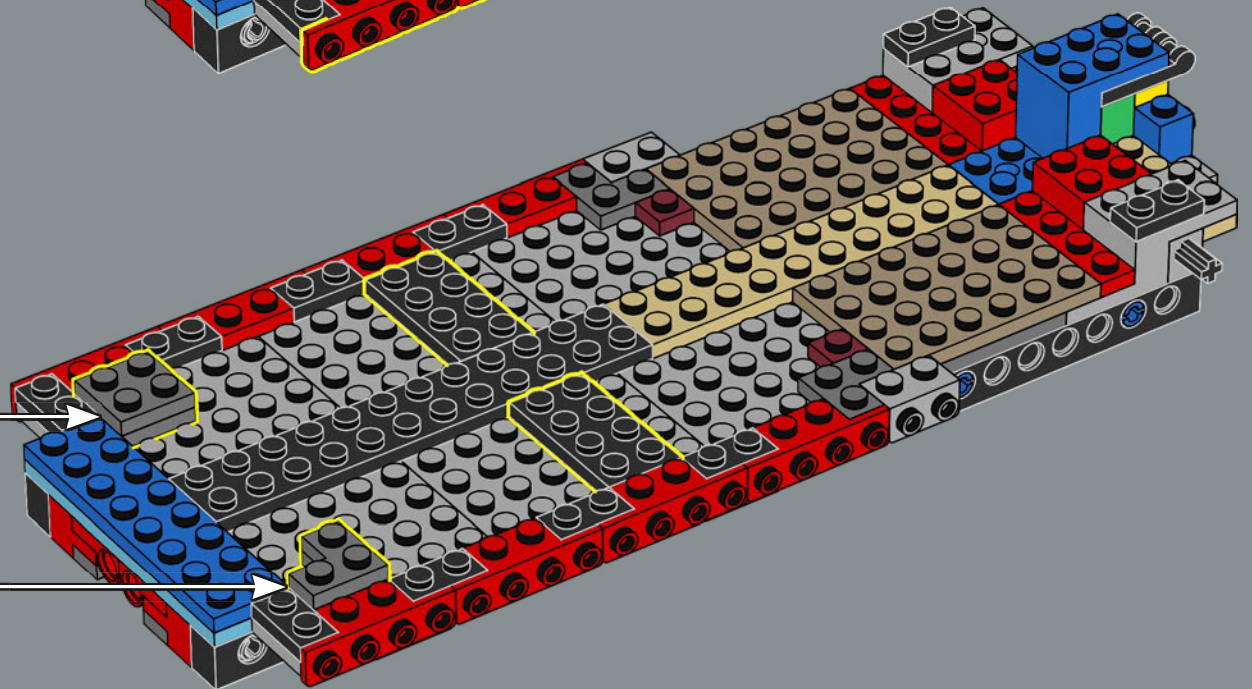
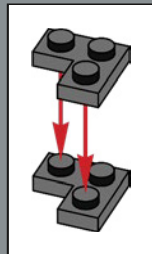
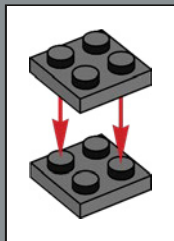

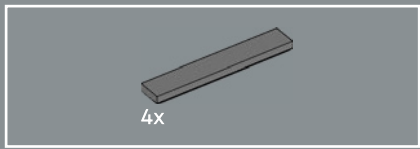

21

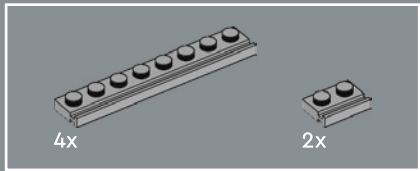
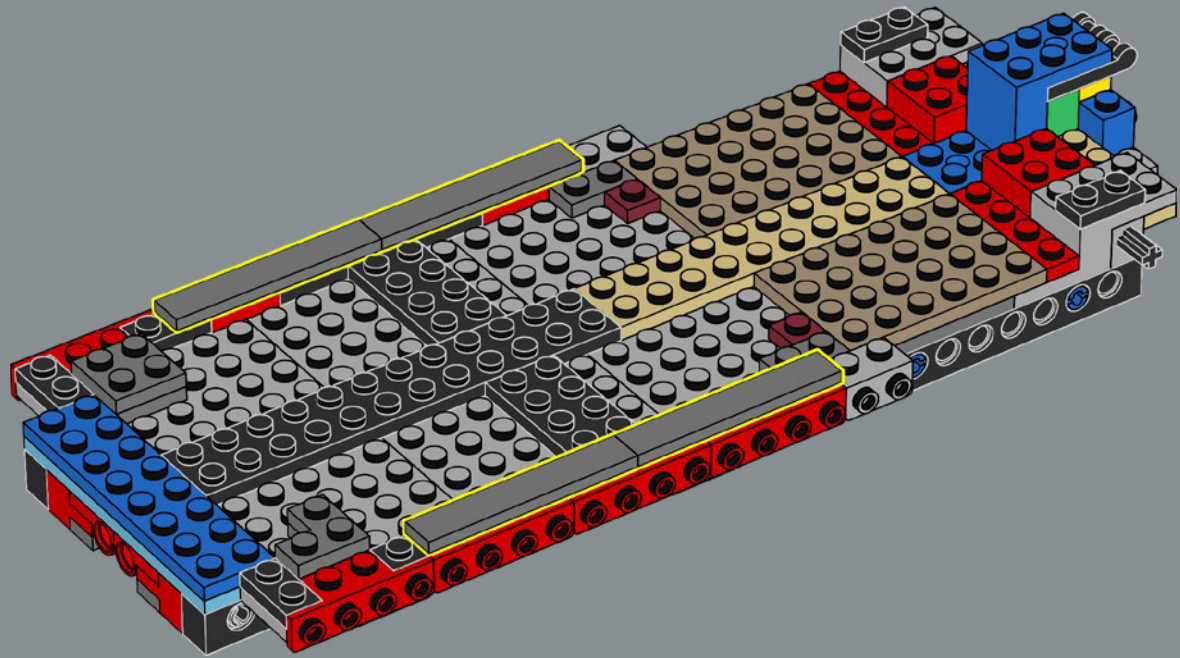

22

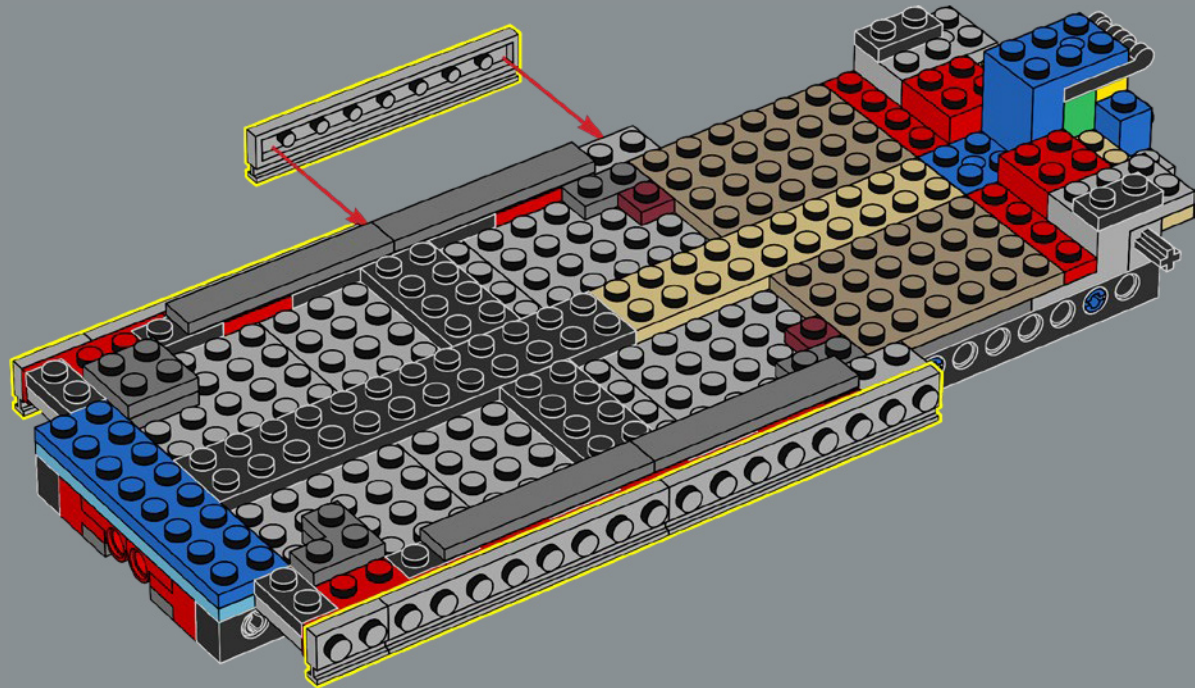



23

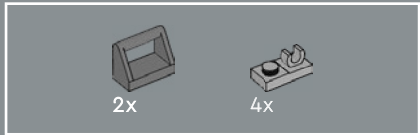
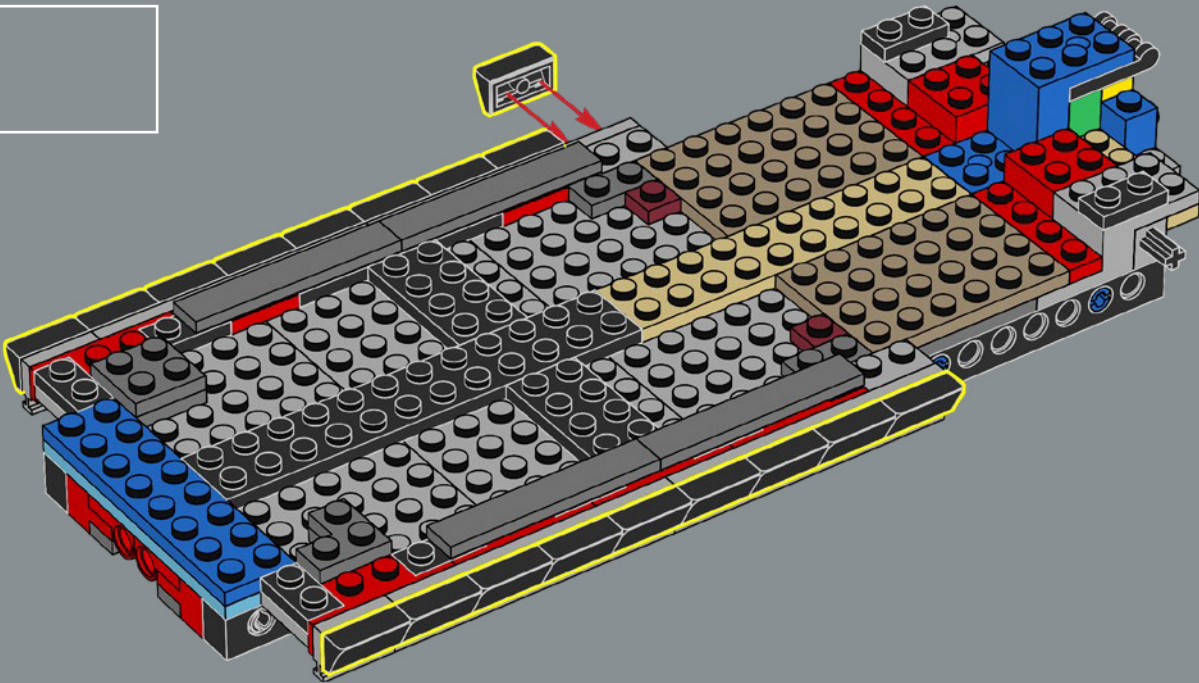

24

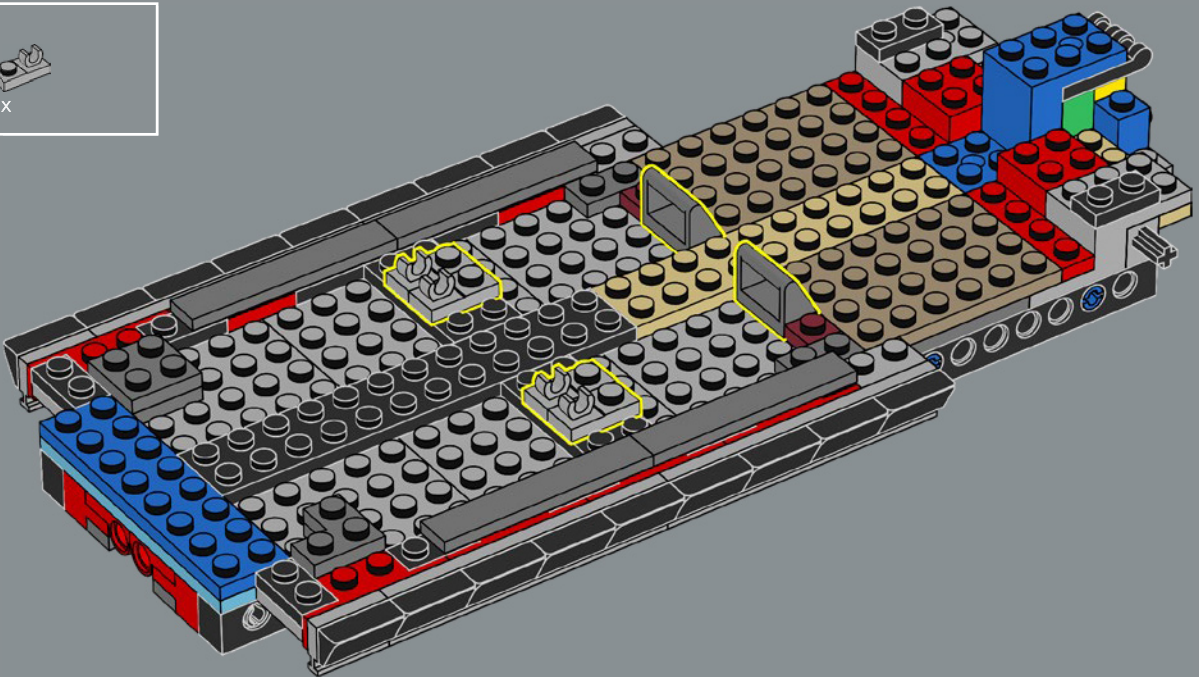



4x

25

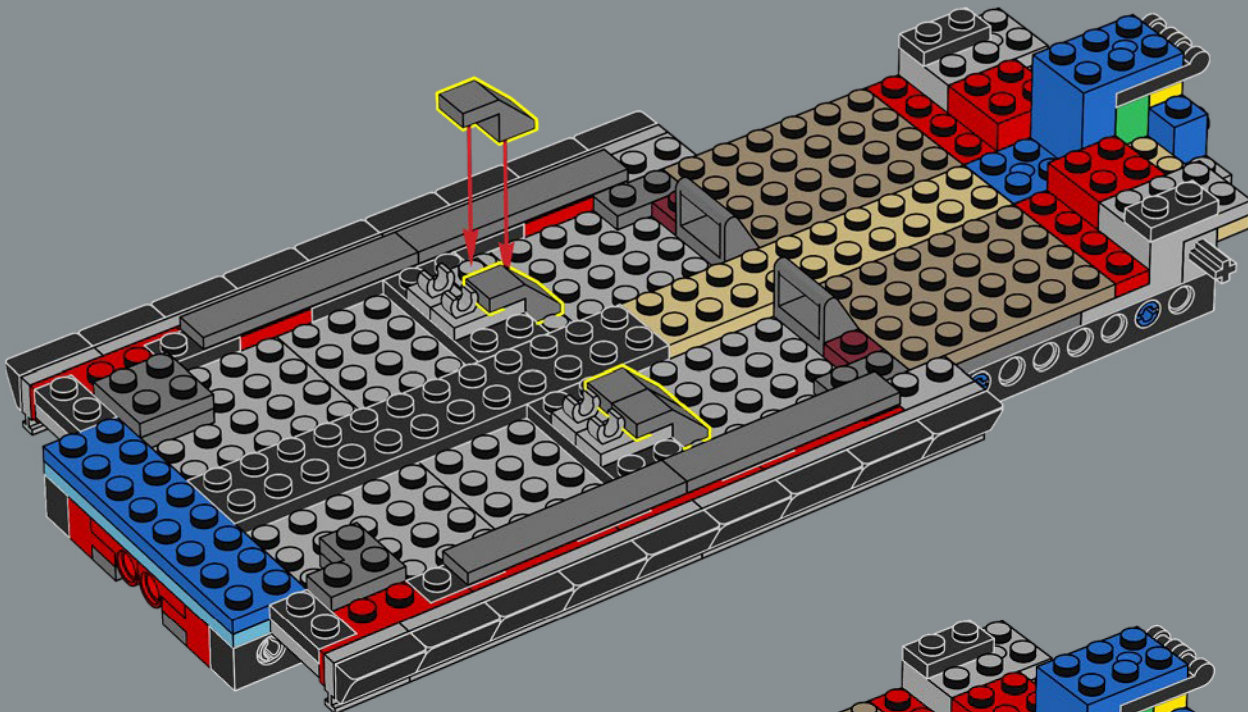

1x



1x



1x

26

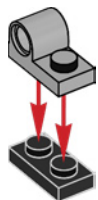
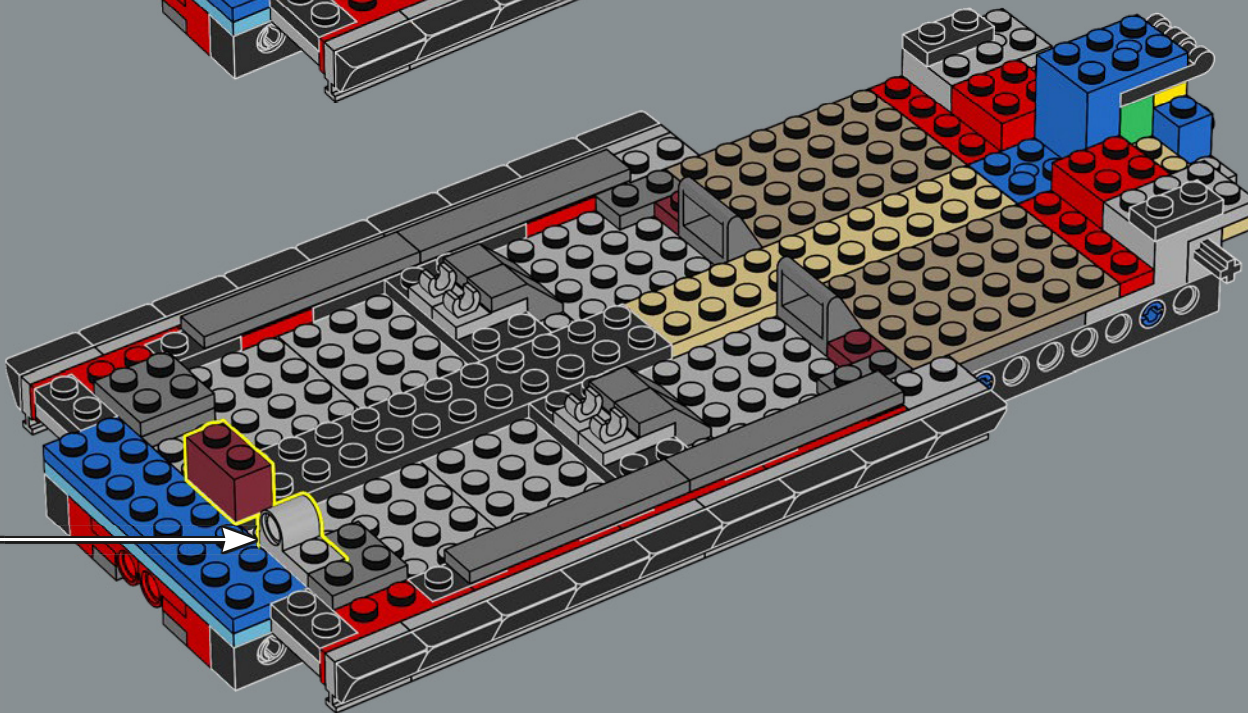

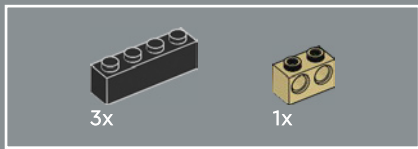

27

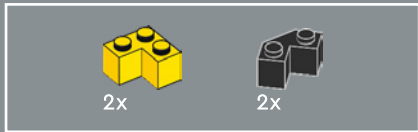
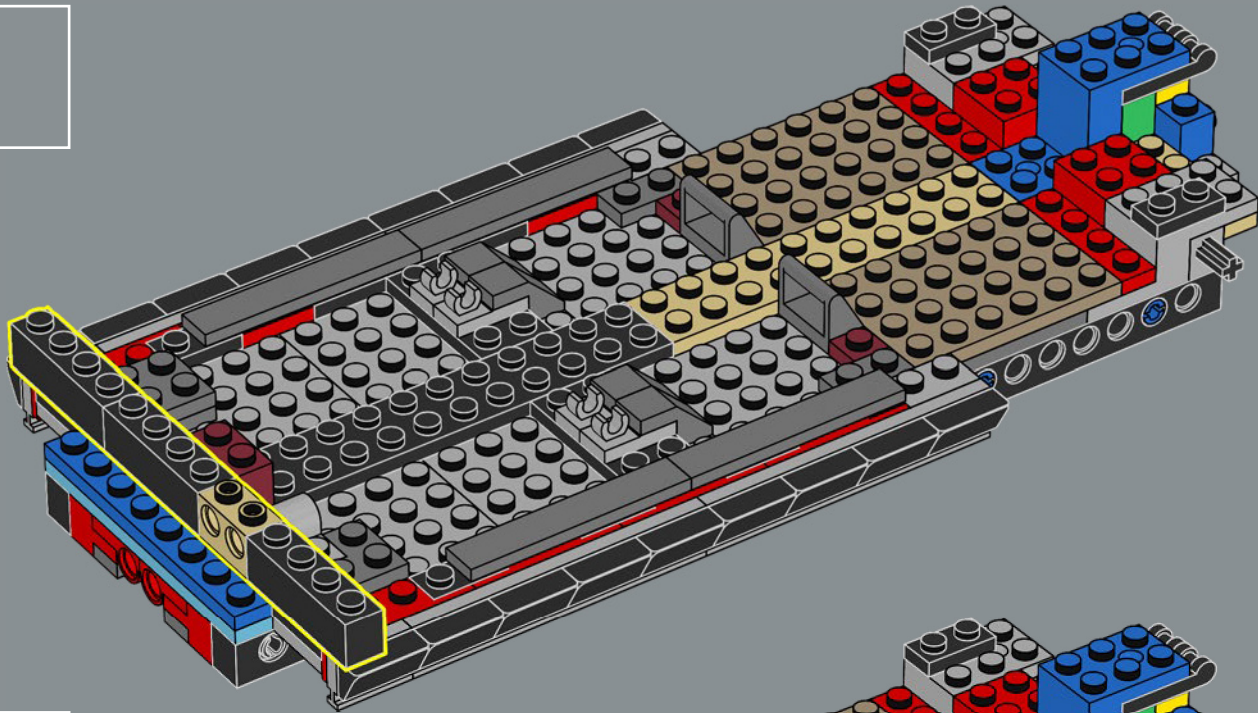

28

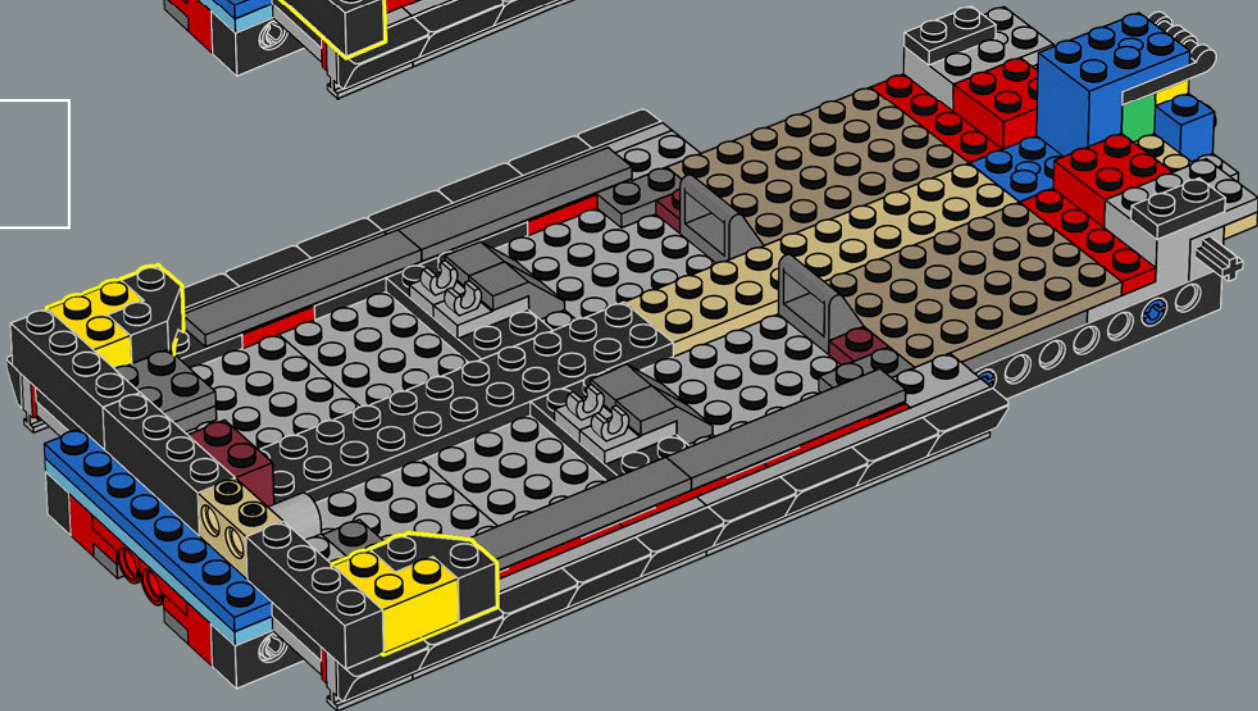



29

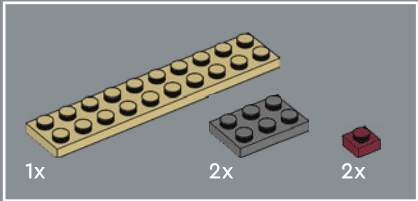
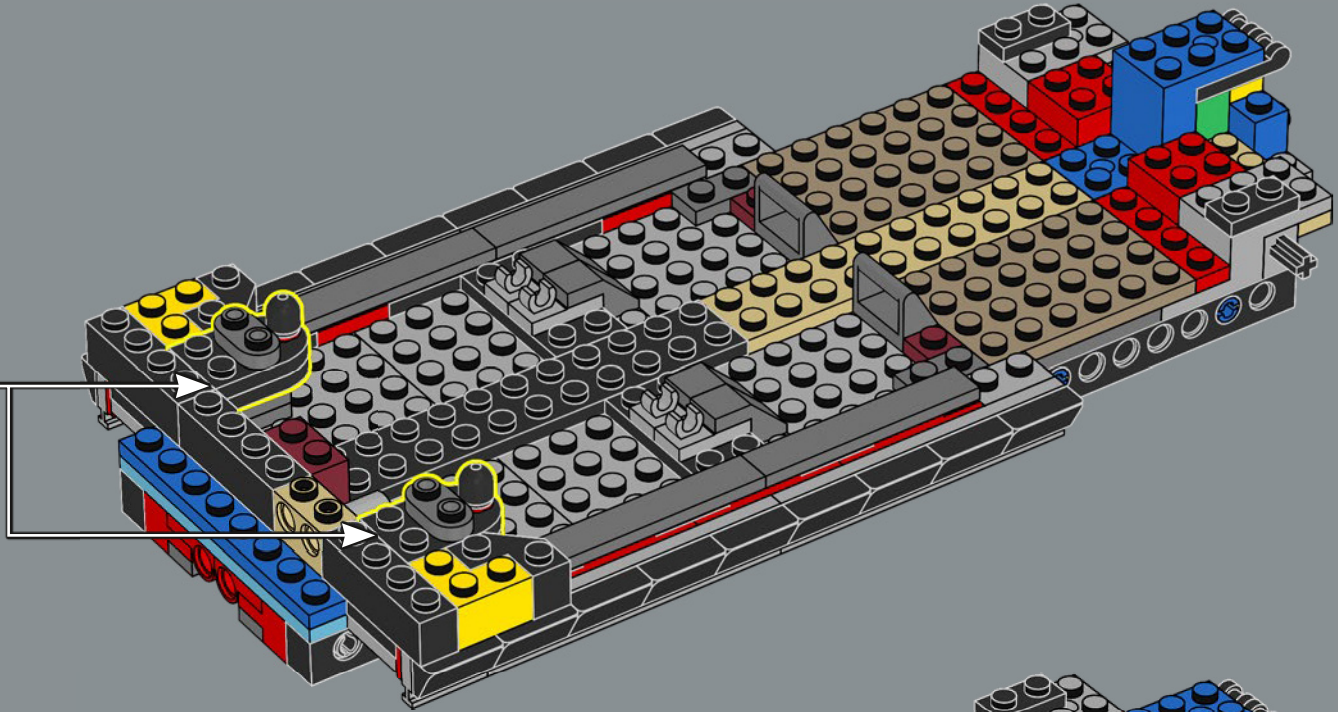
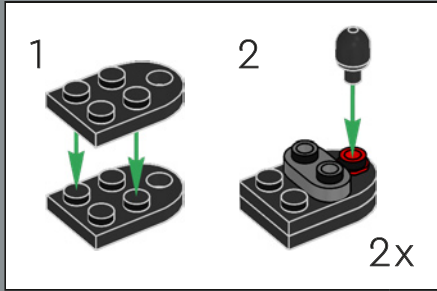

30

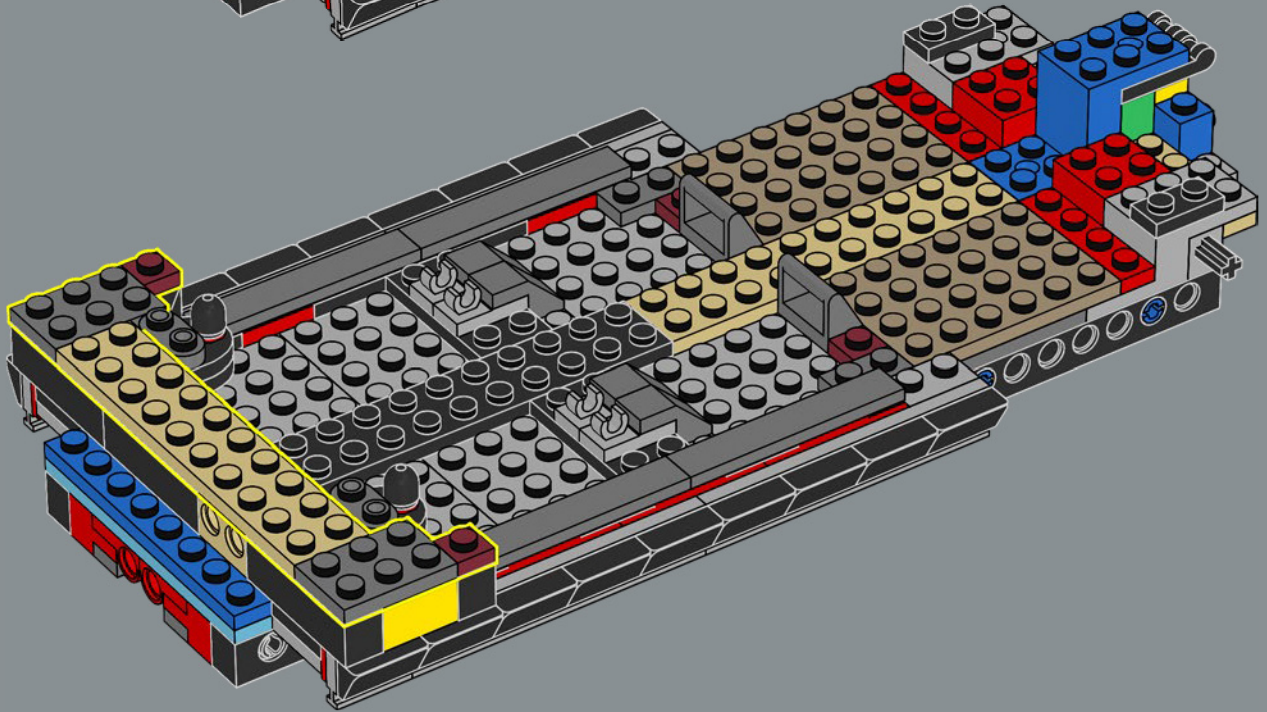

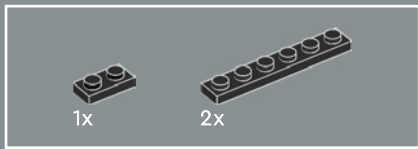

31

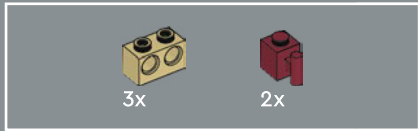
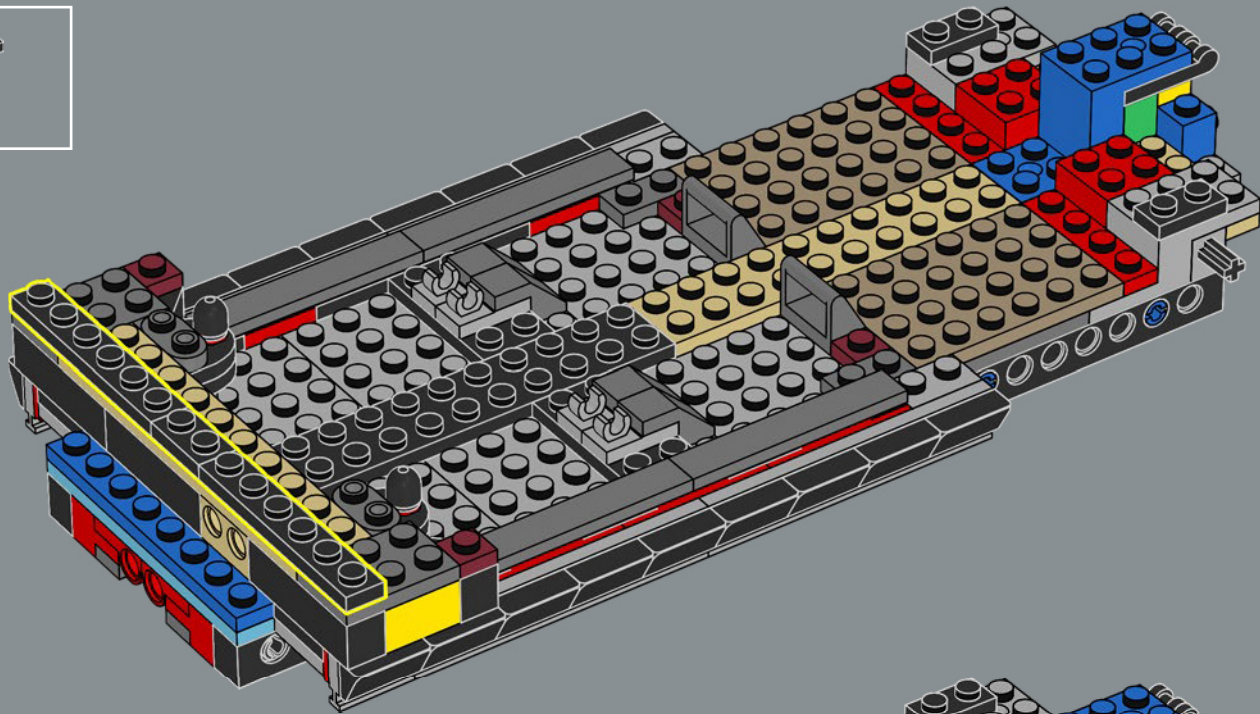

32

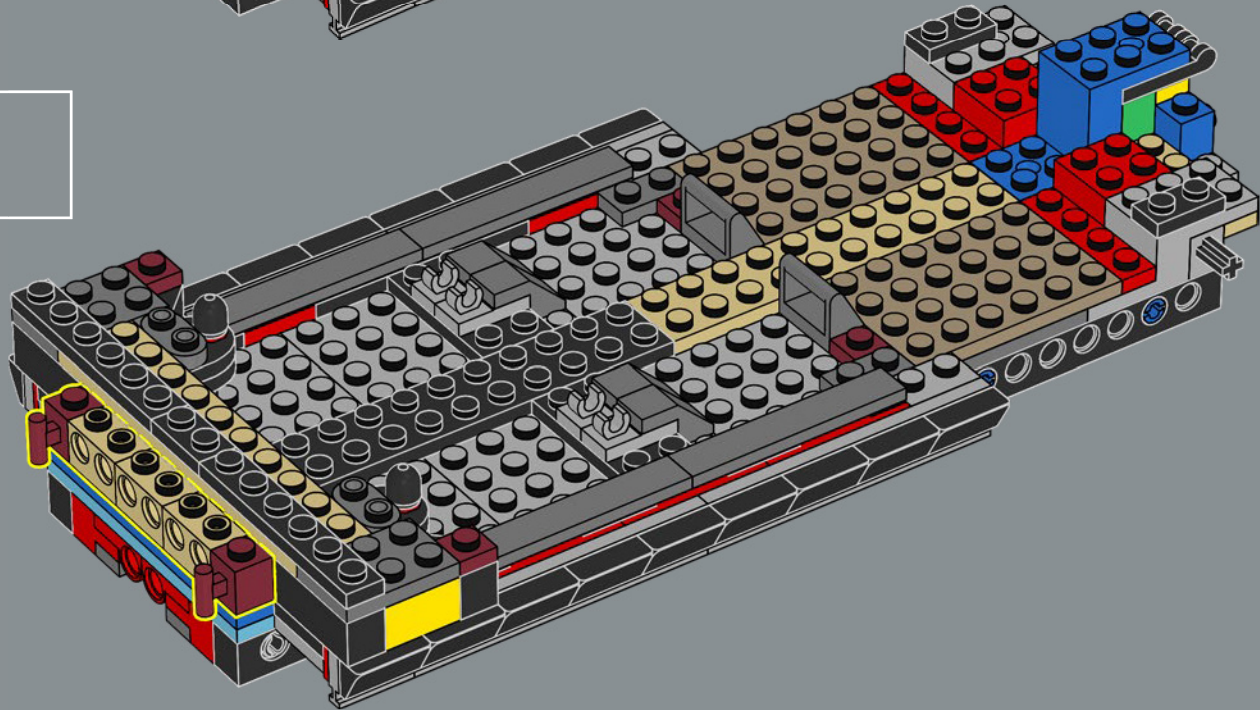

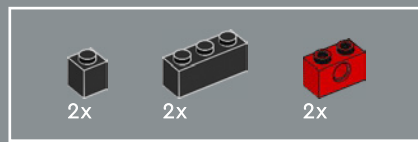

33

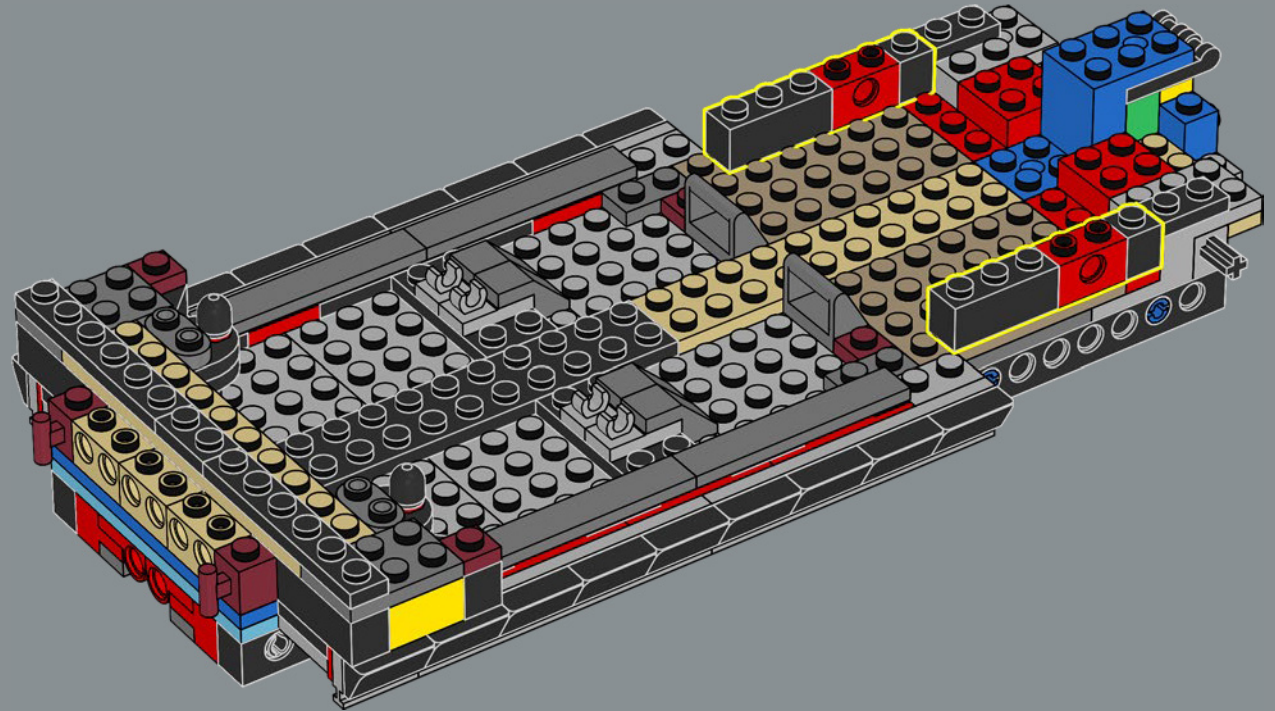

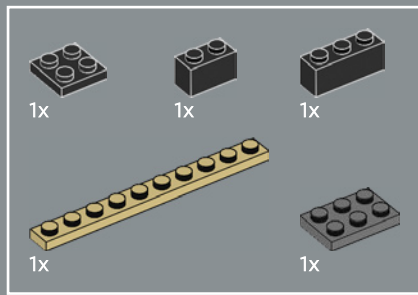

34

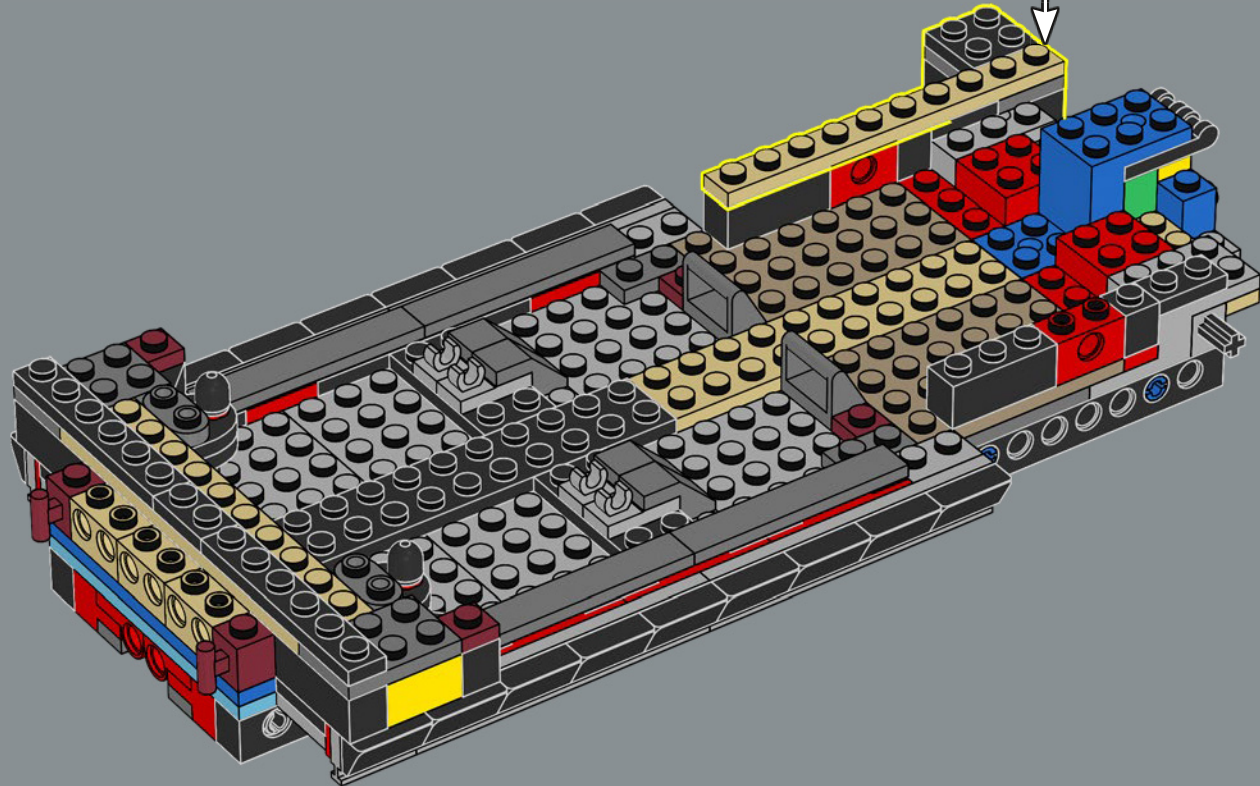
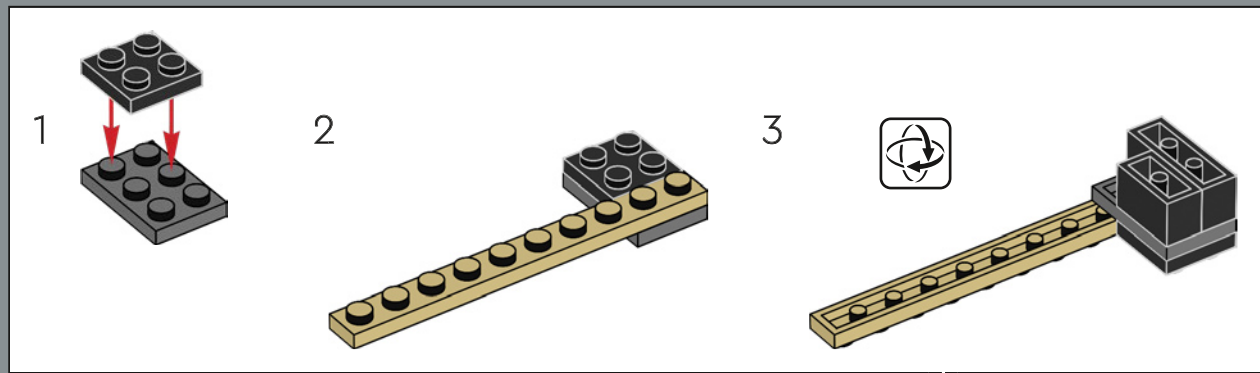

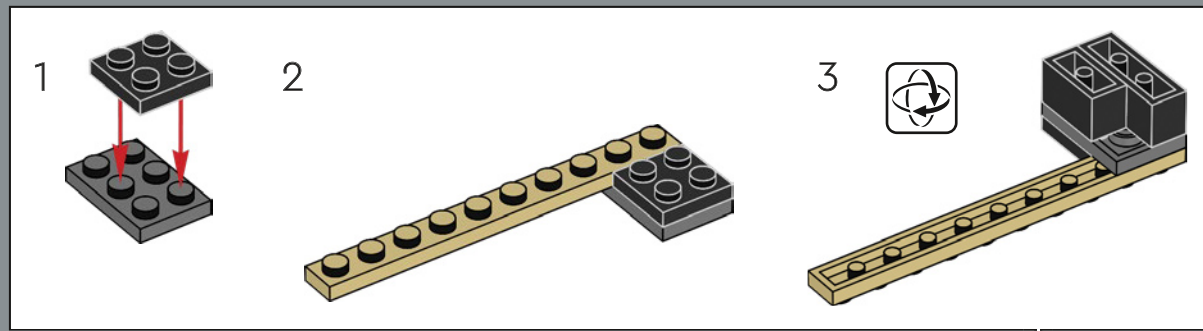
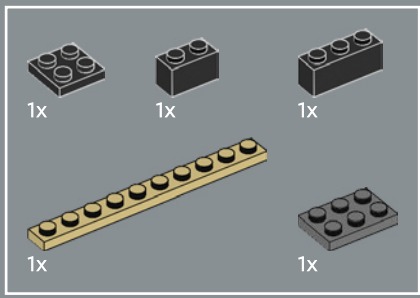

35

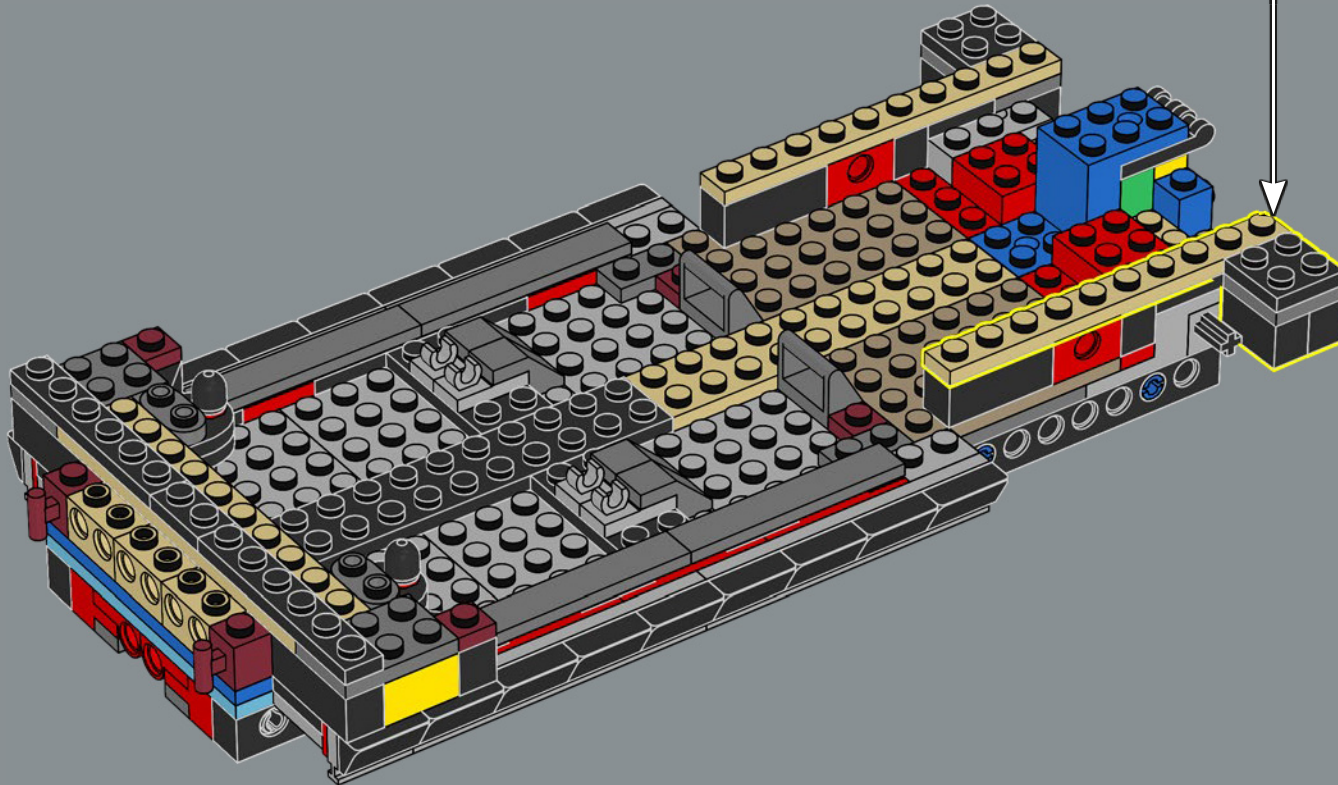

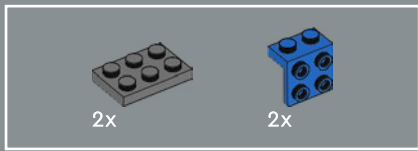

36

Il nome in codice della Camaro prima del suo lancio era "Panther", ovvero Pantera.

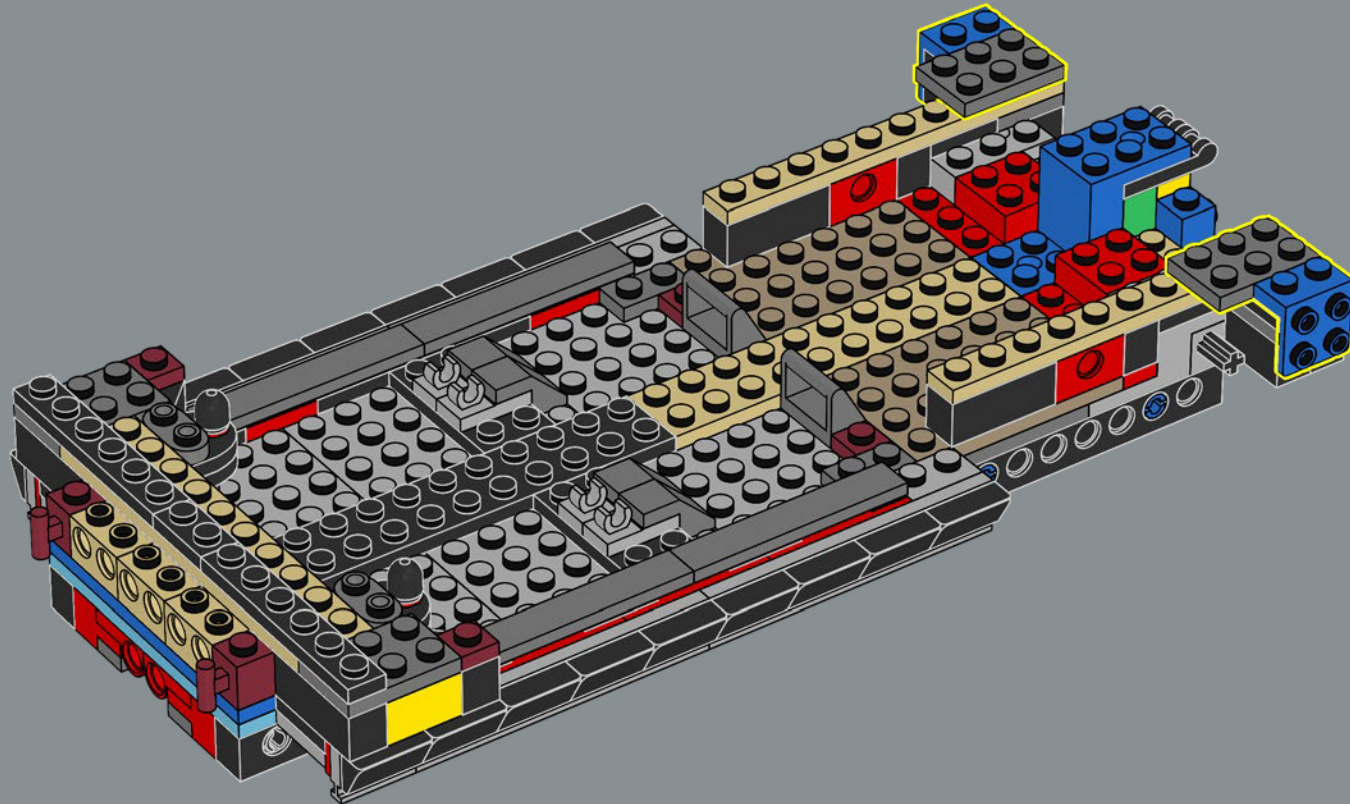

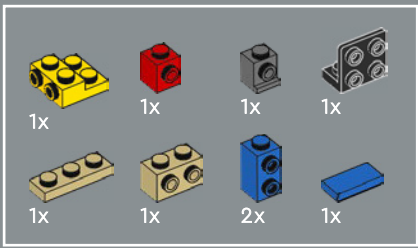

37

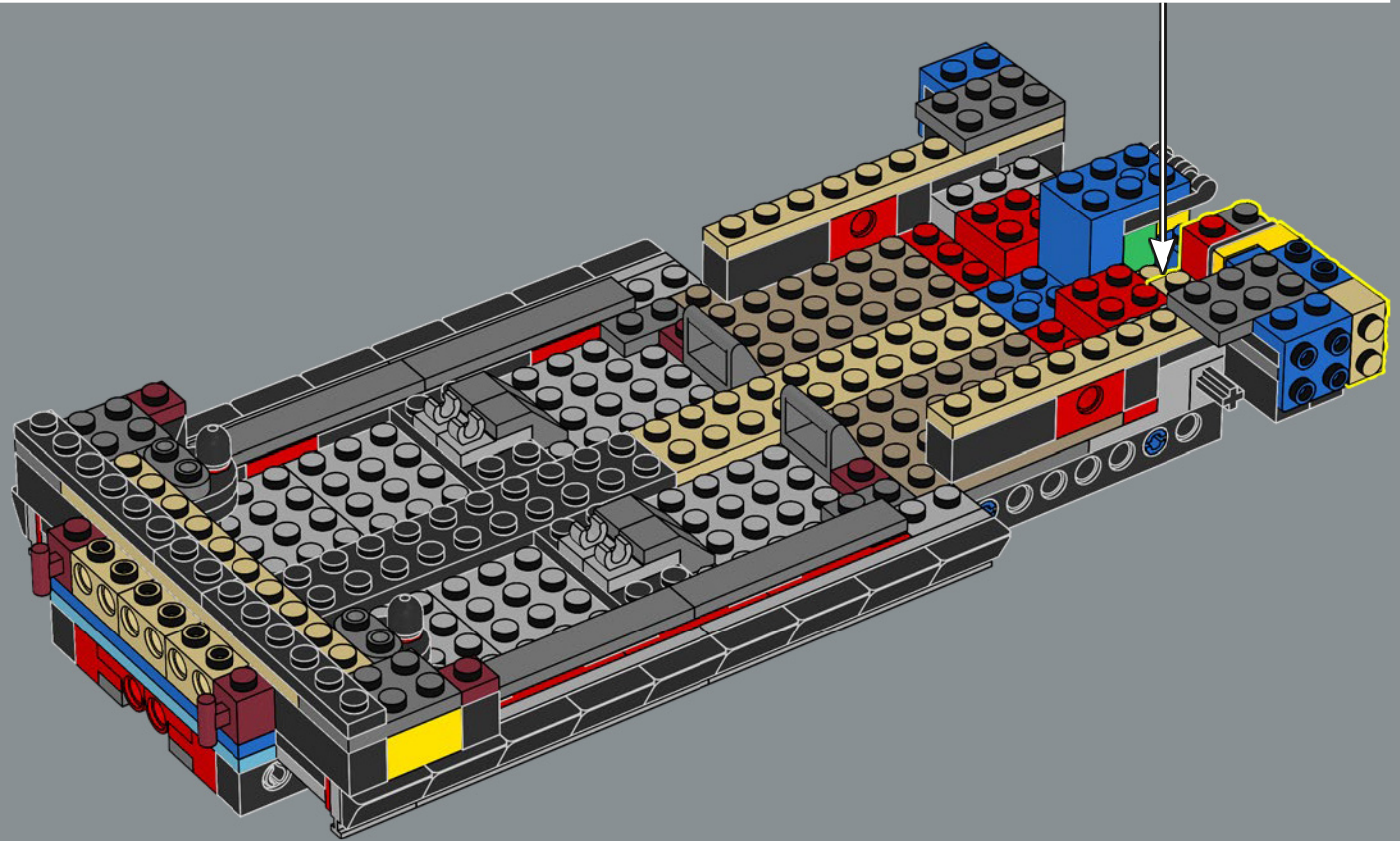
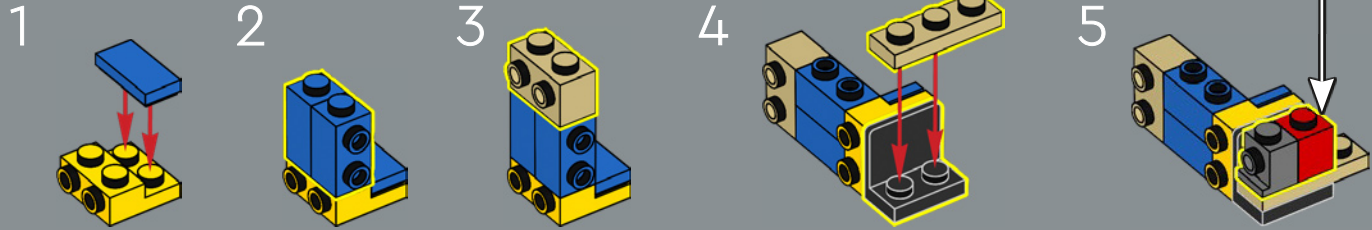

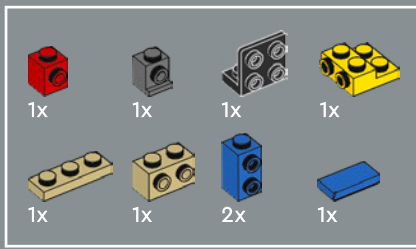

38

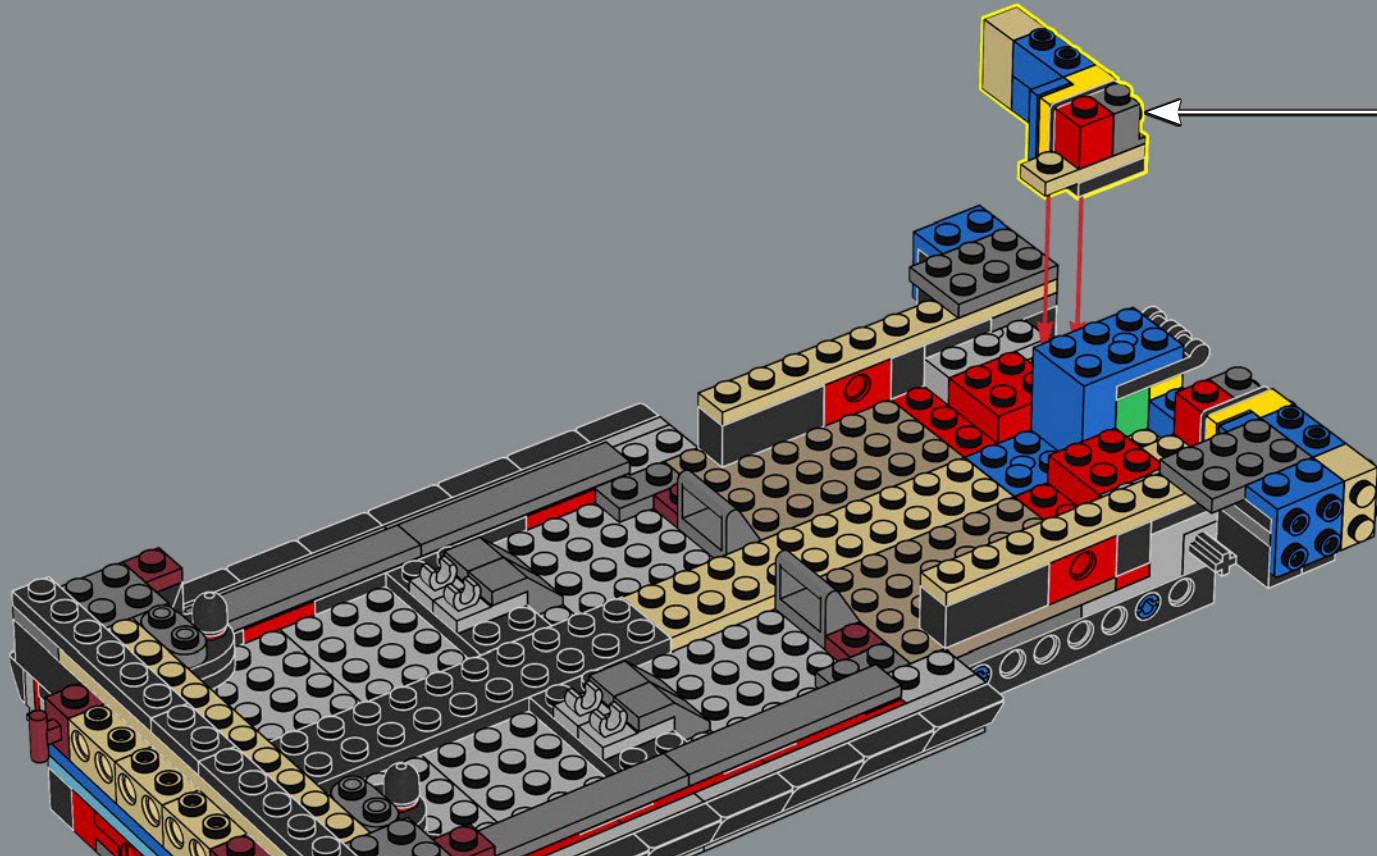
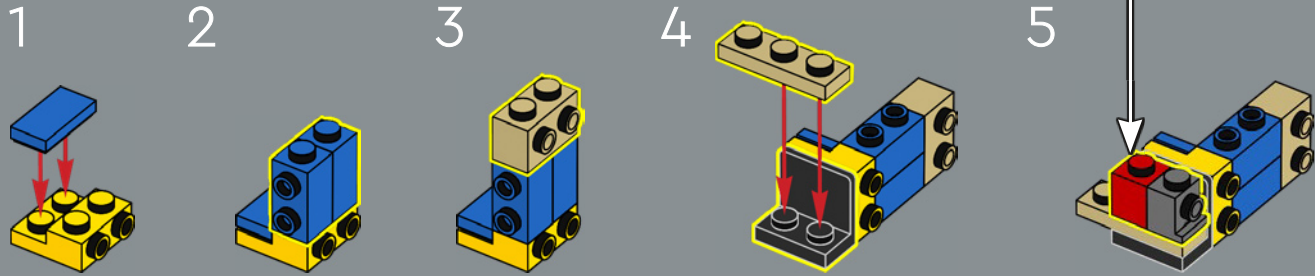

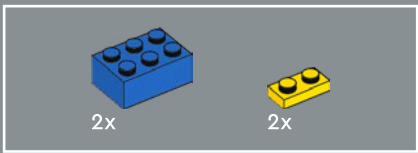

39

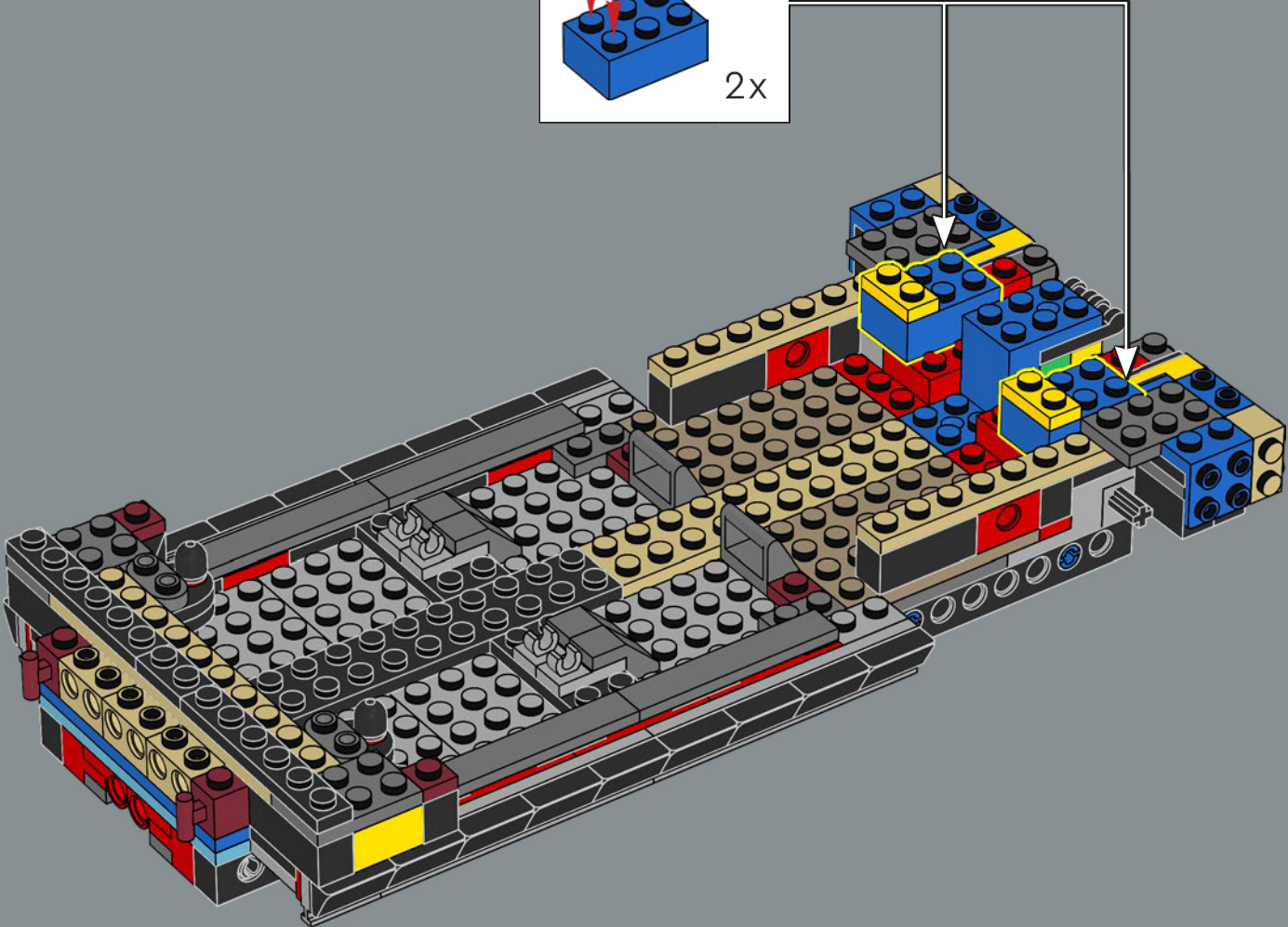
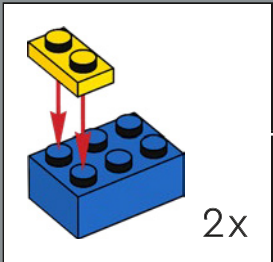

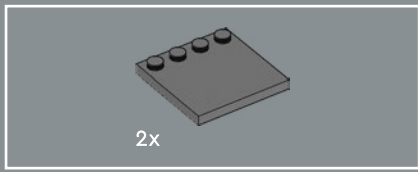

40

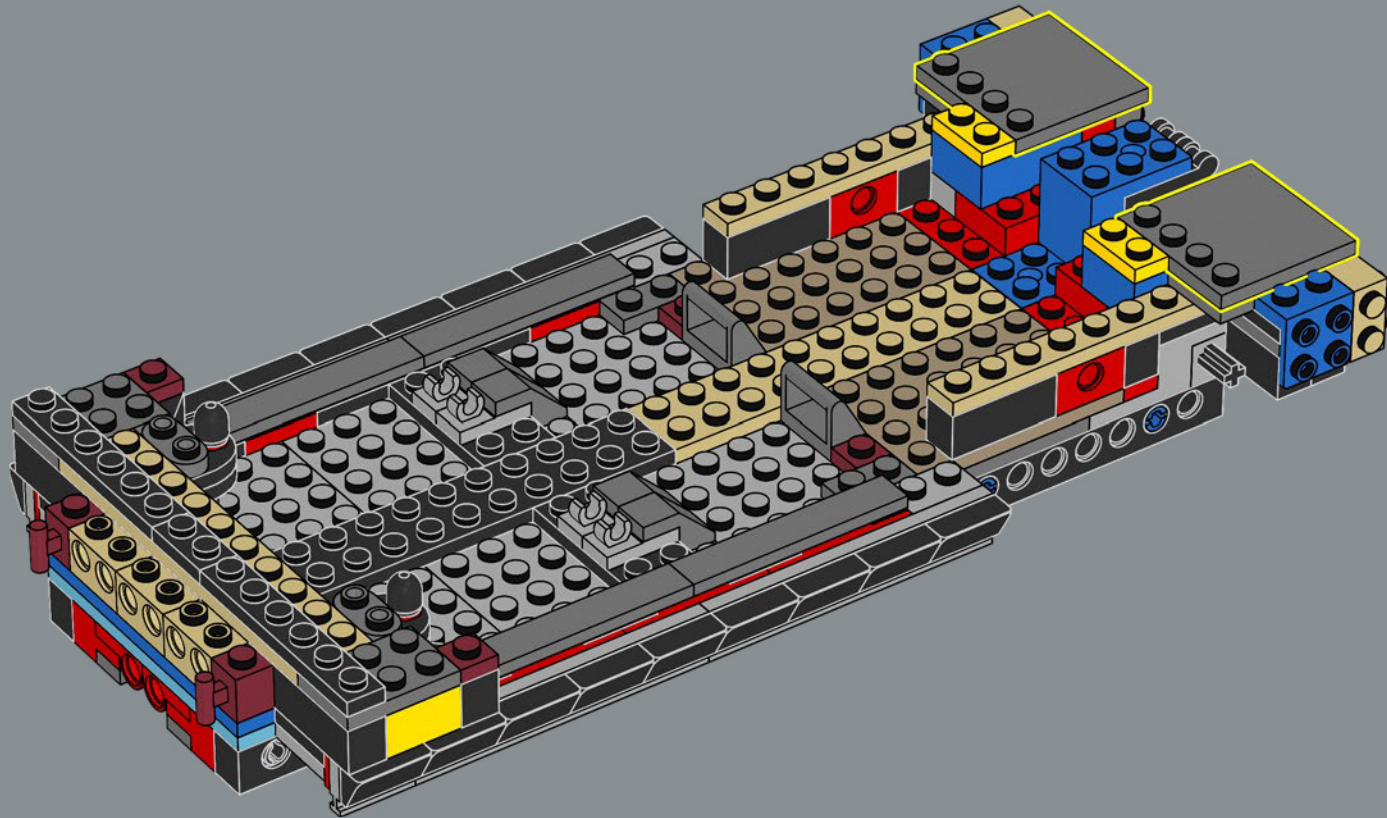



41

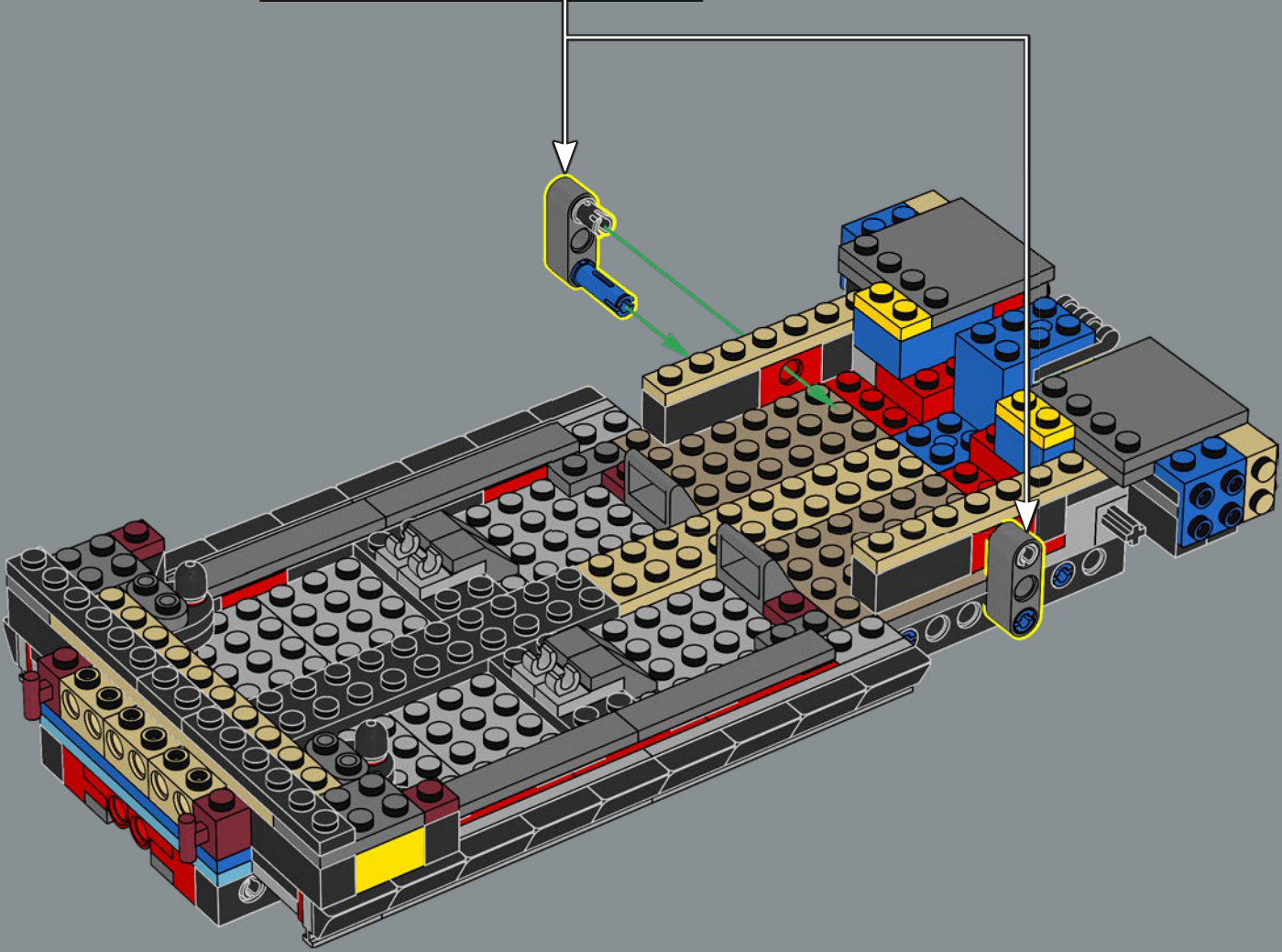
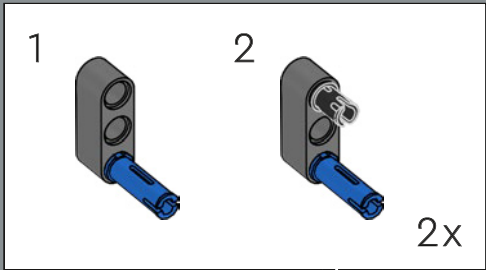

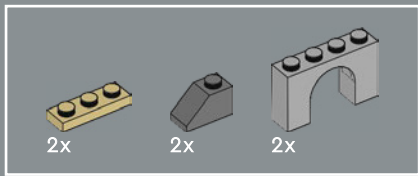

42

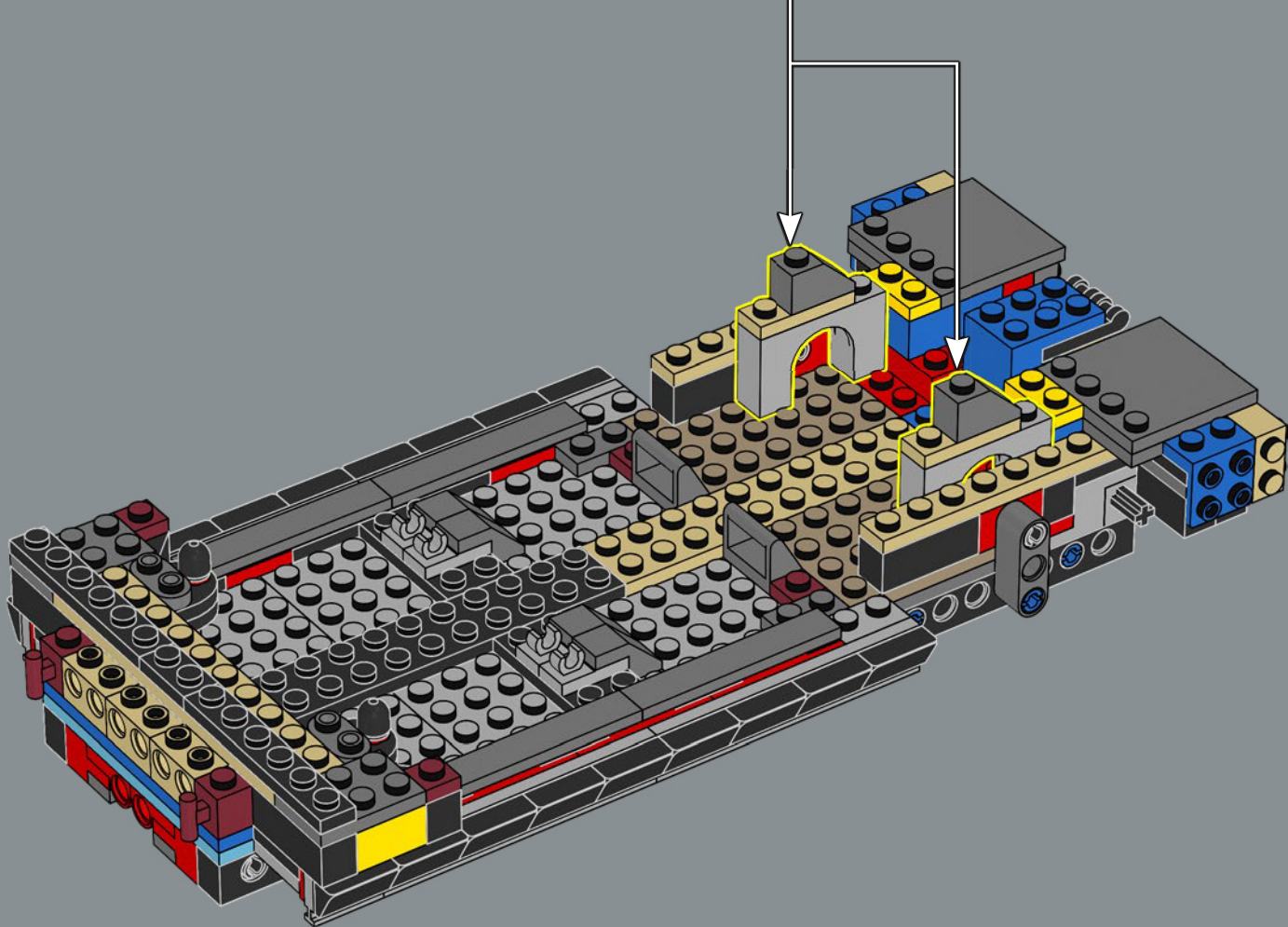
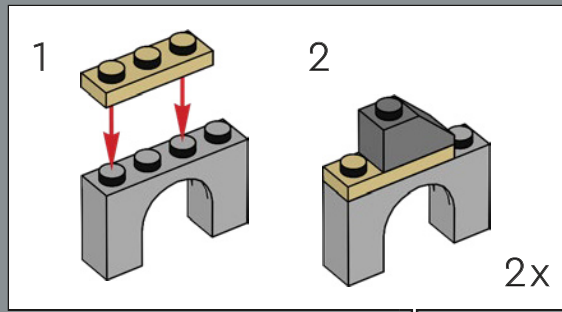

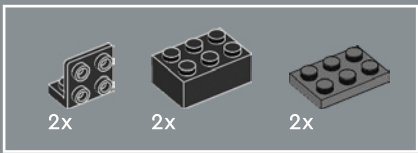

43

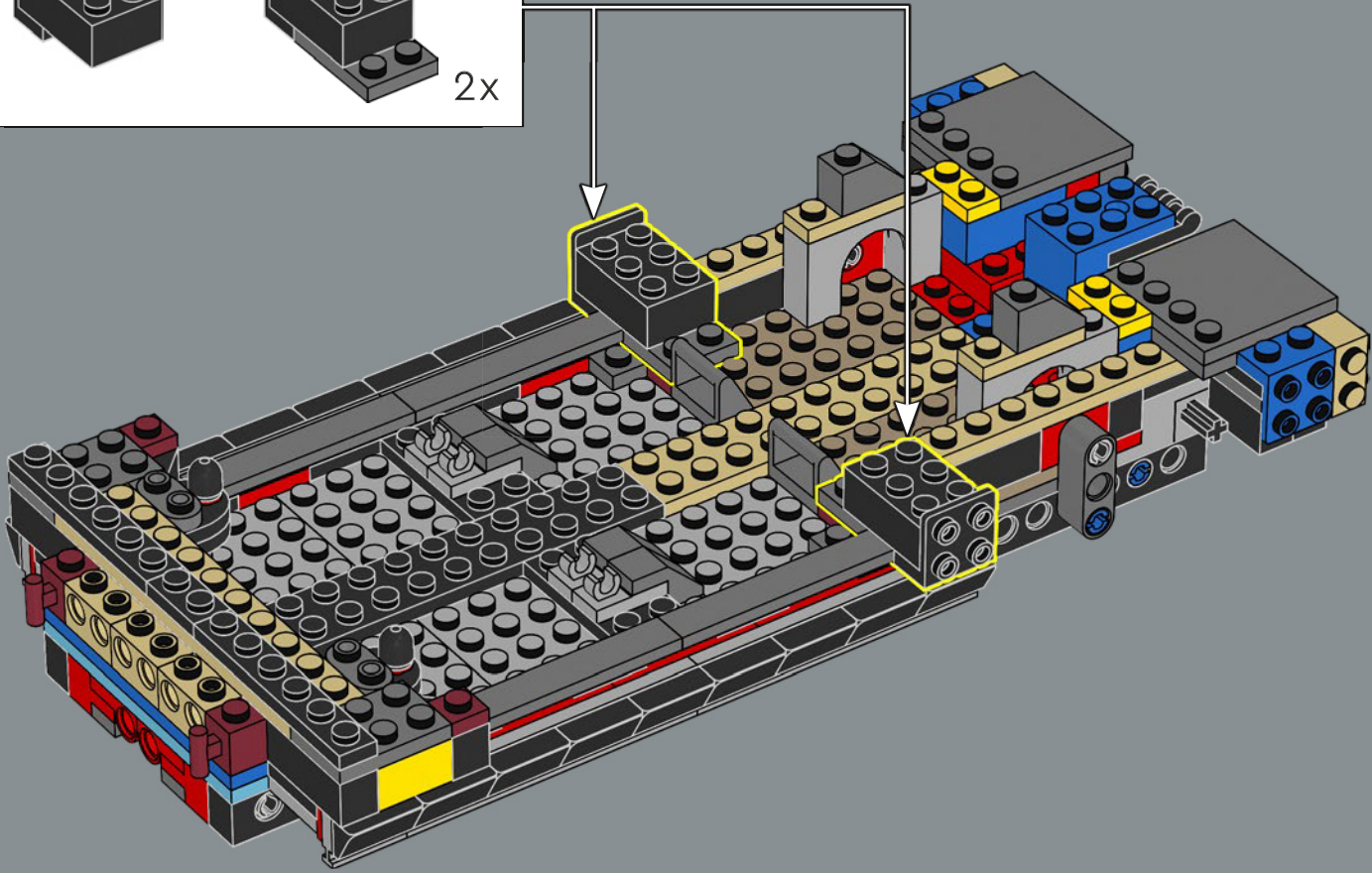
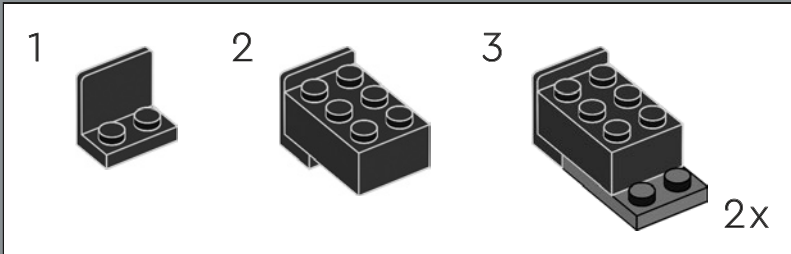

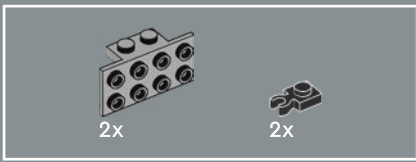

44

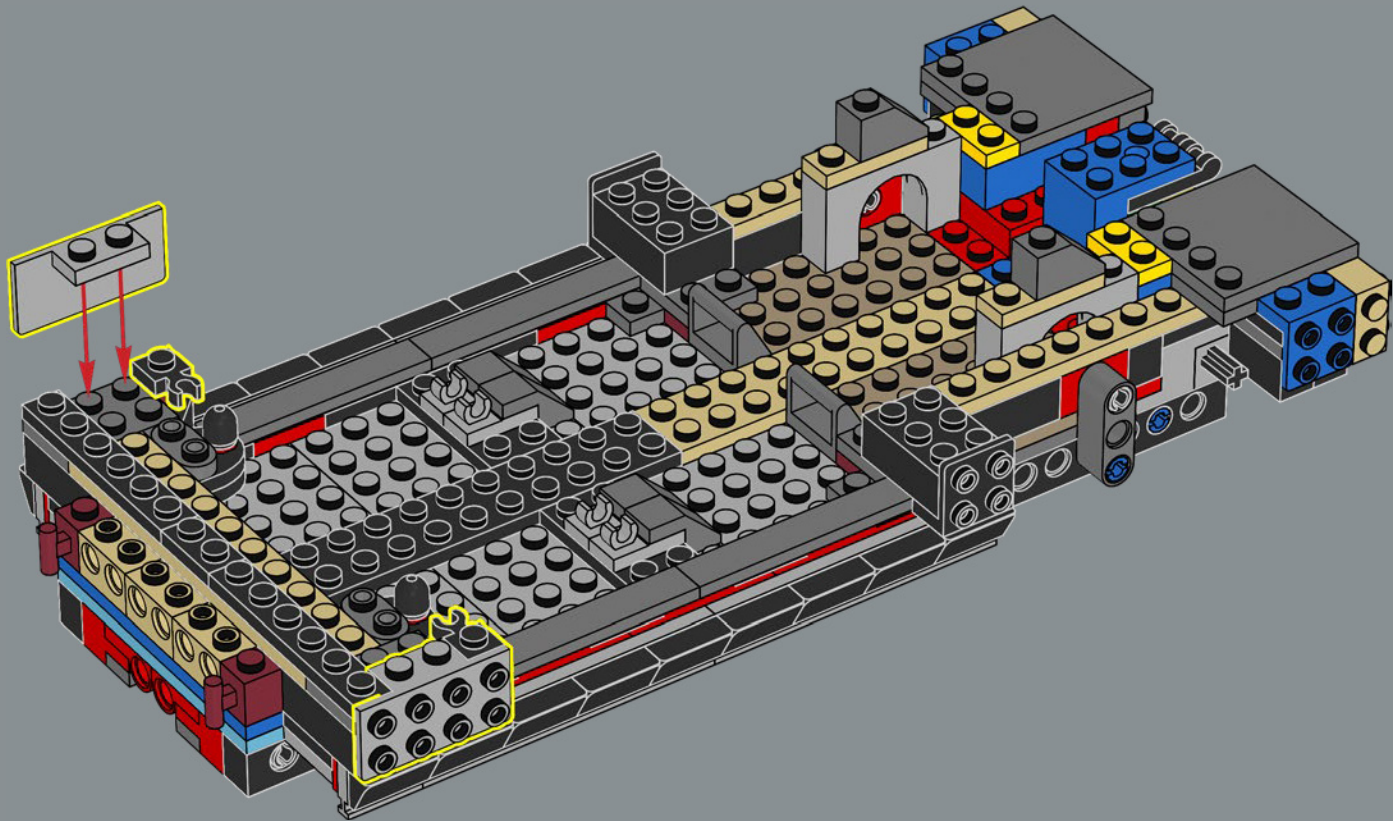

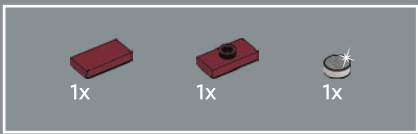

45

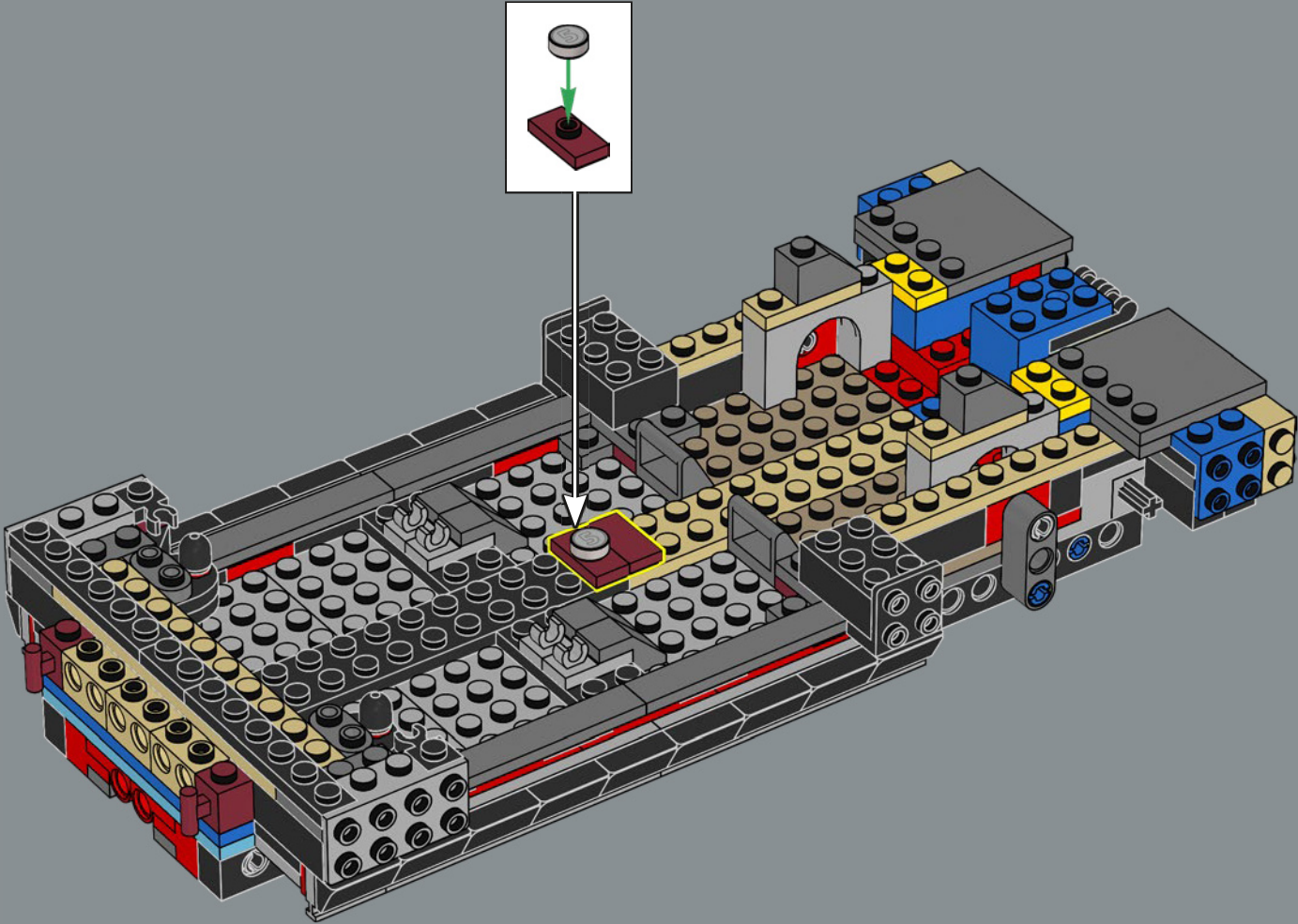

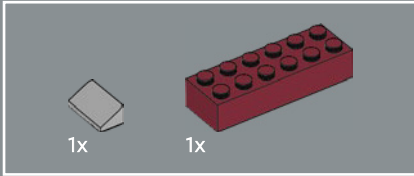
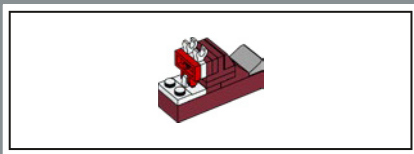

46

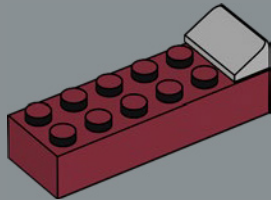

47

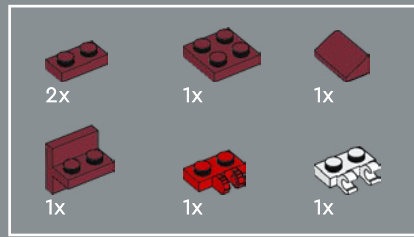
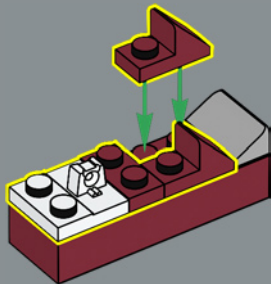

48

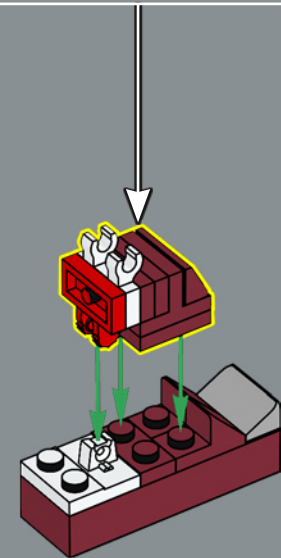
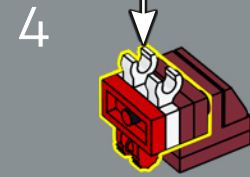
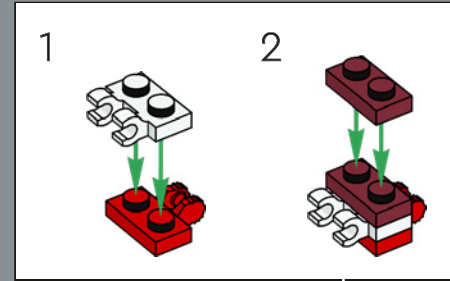
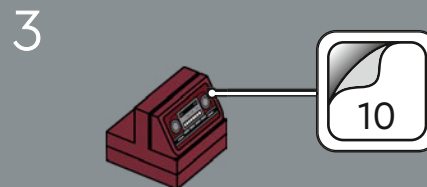
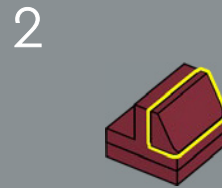
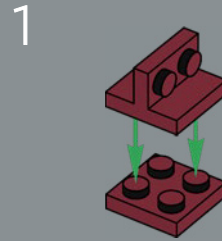

Il primo prototipo della Camaro mai costruito, il telaio n. 10001, esiste ancora ed è iscritto al Registro Nazionale dei Veicoli Storici.

49

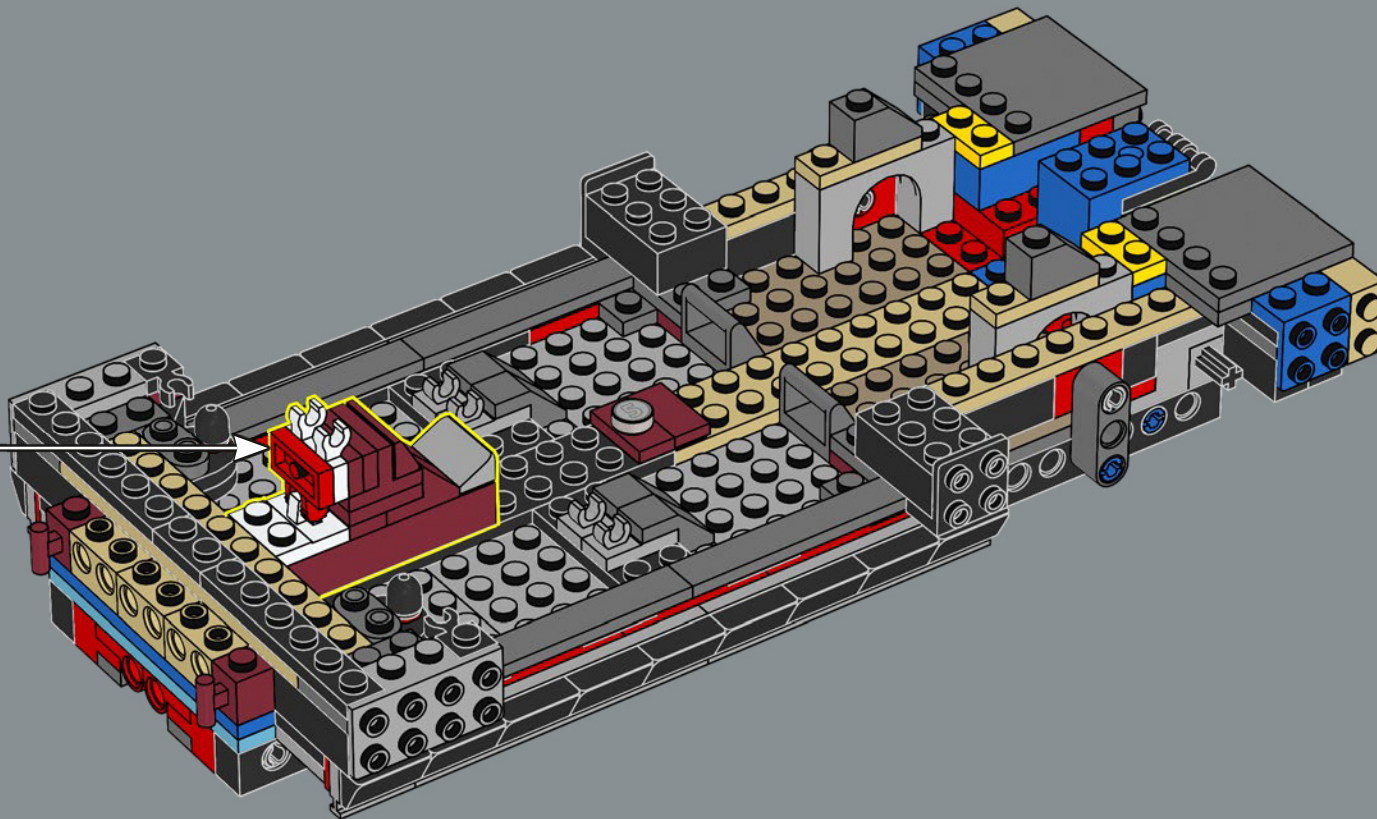

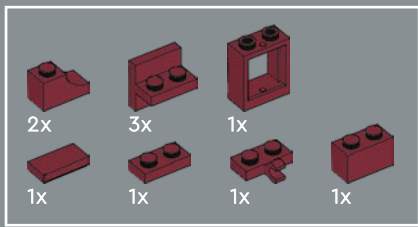

50

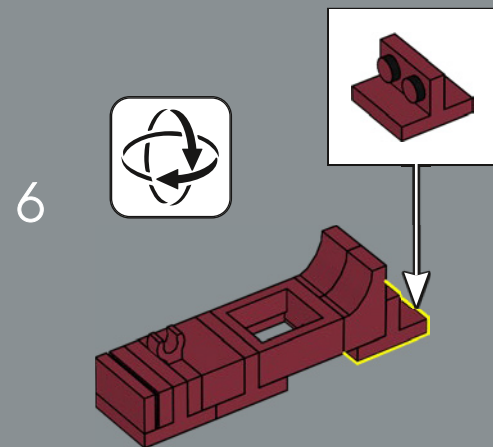
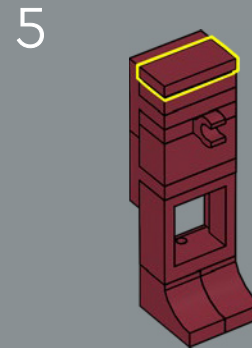
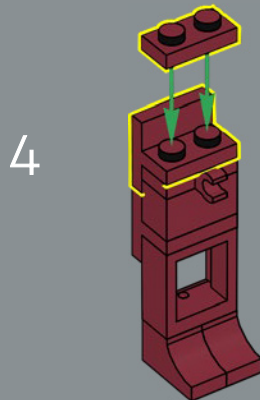
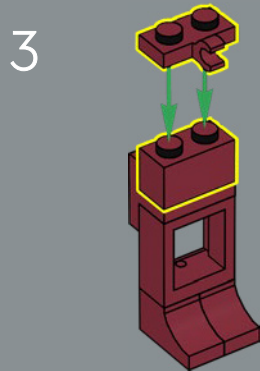
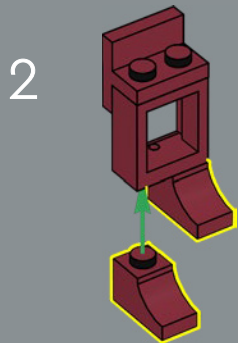
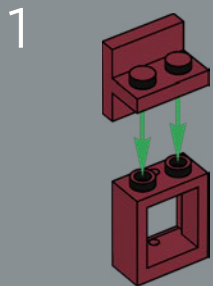

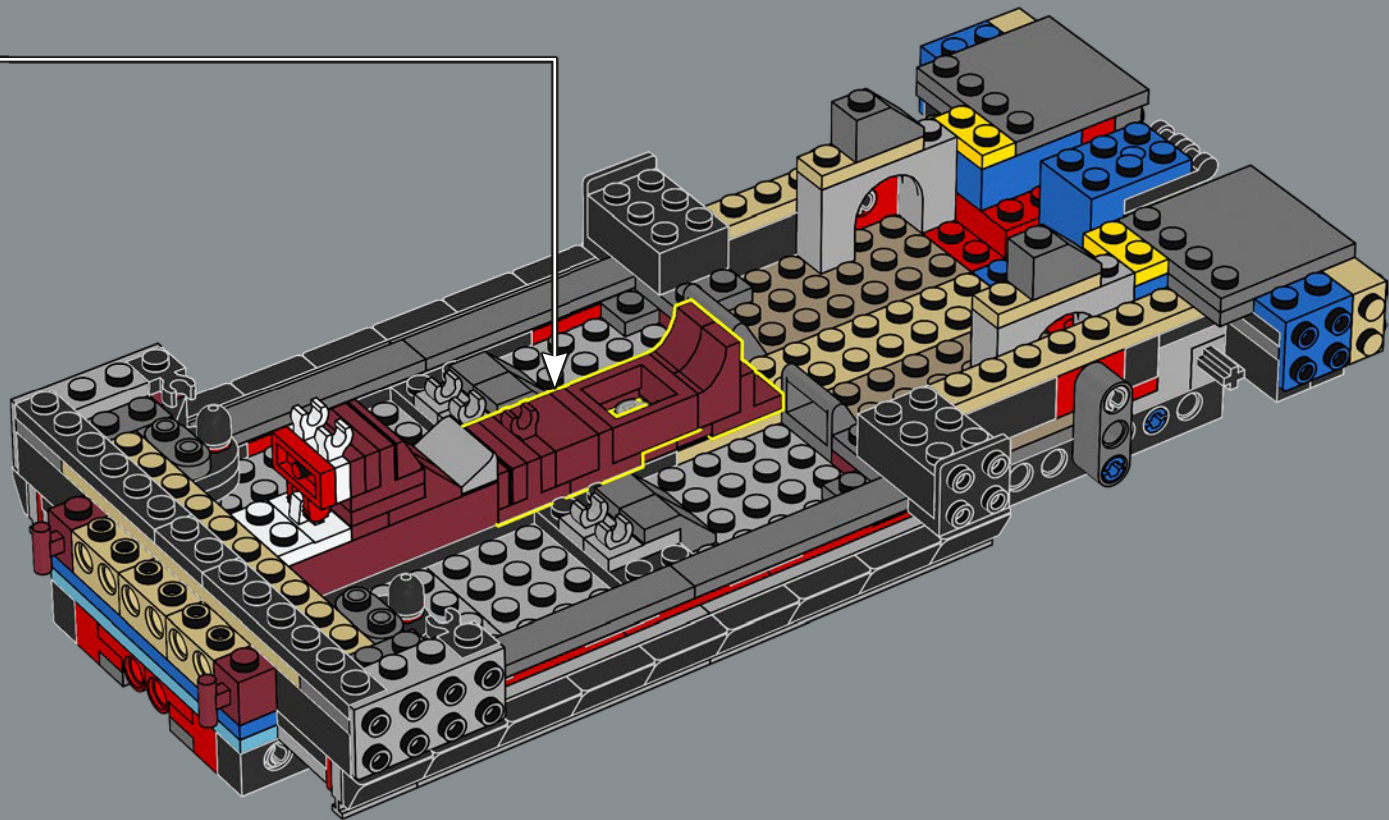

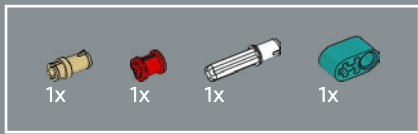

51

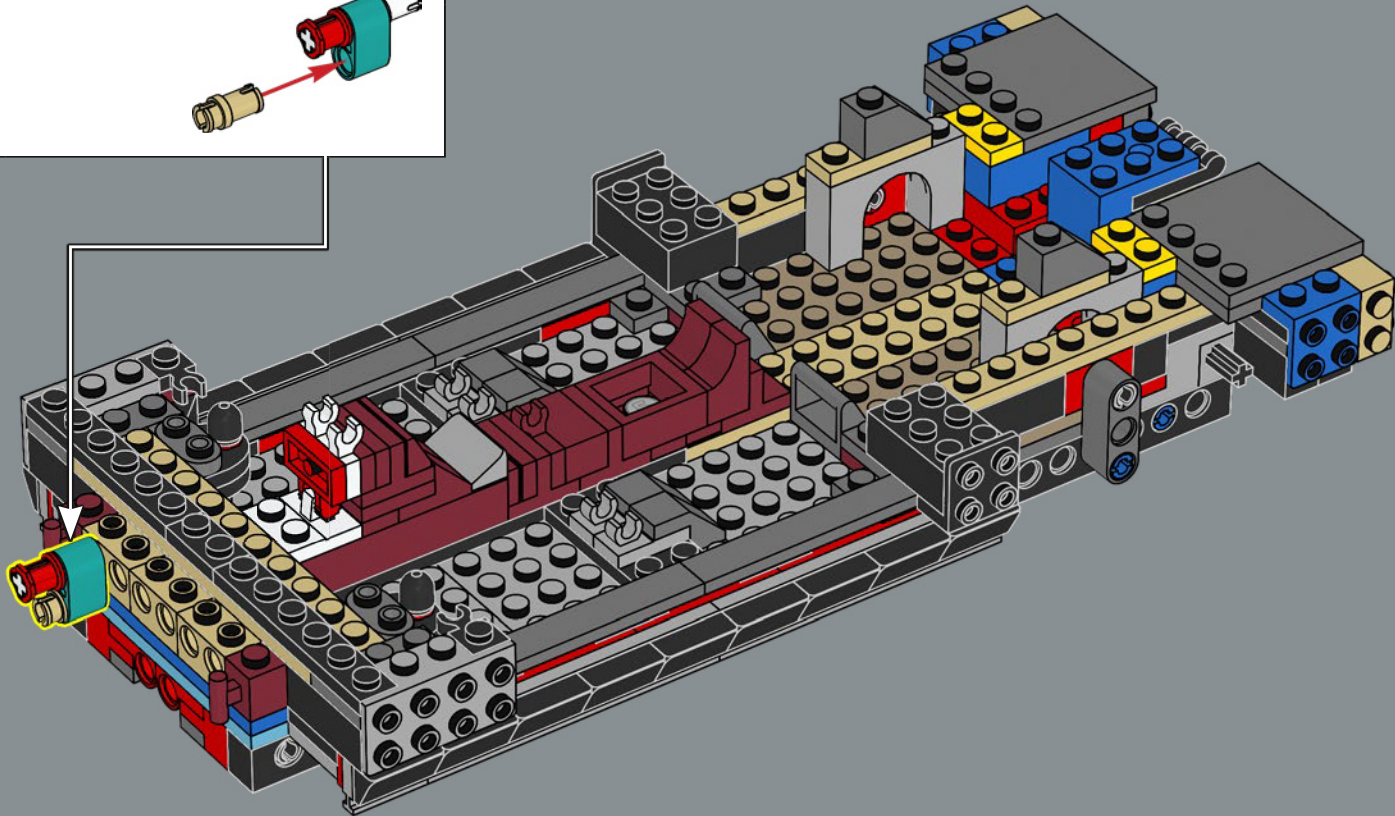
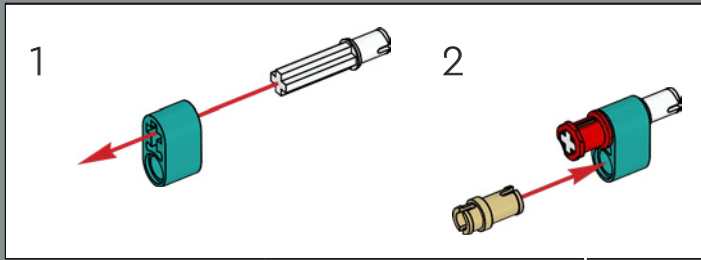

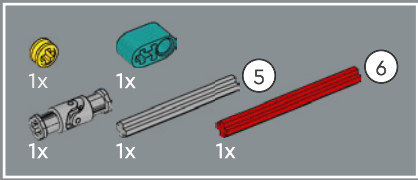

52

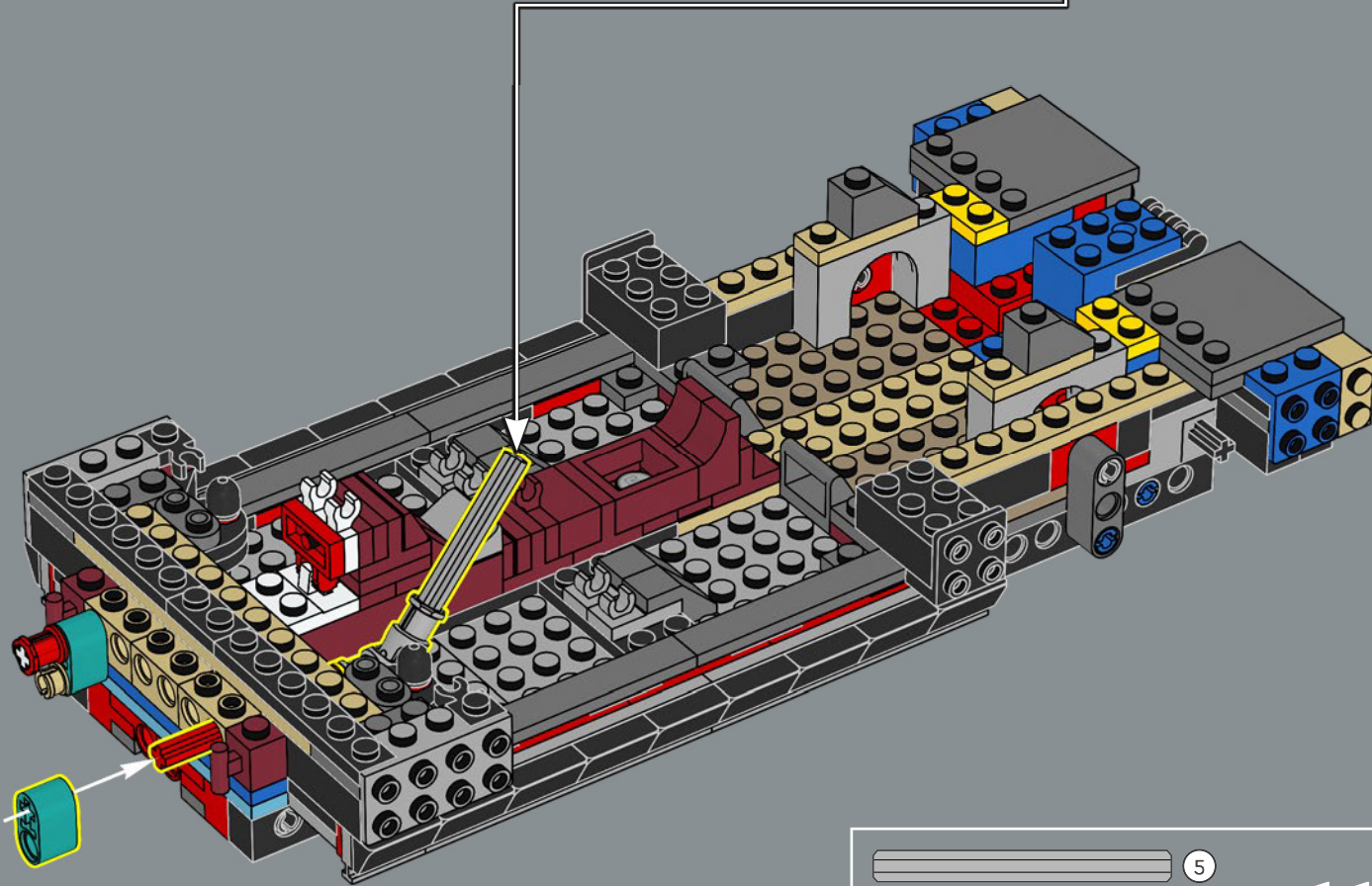
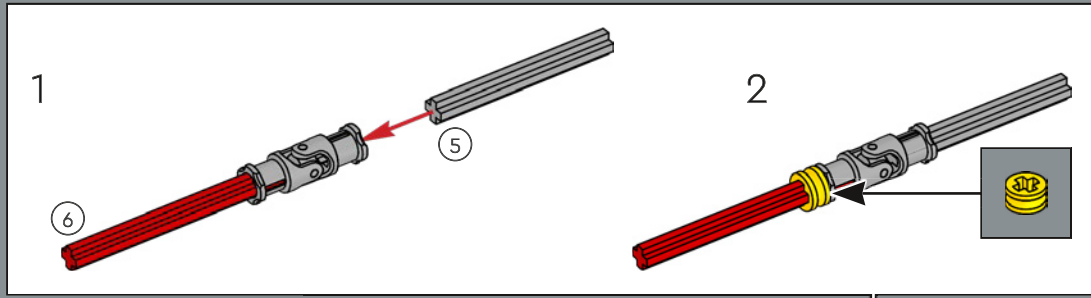



53

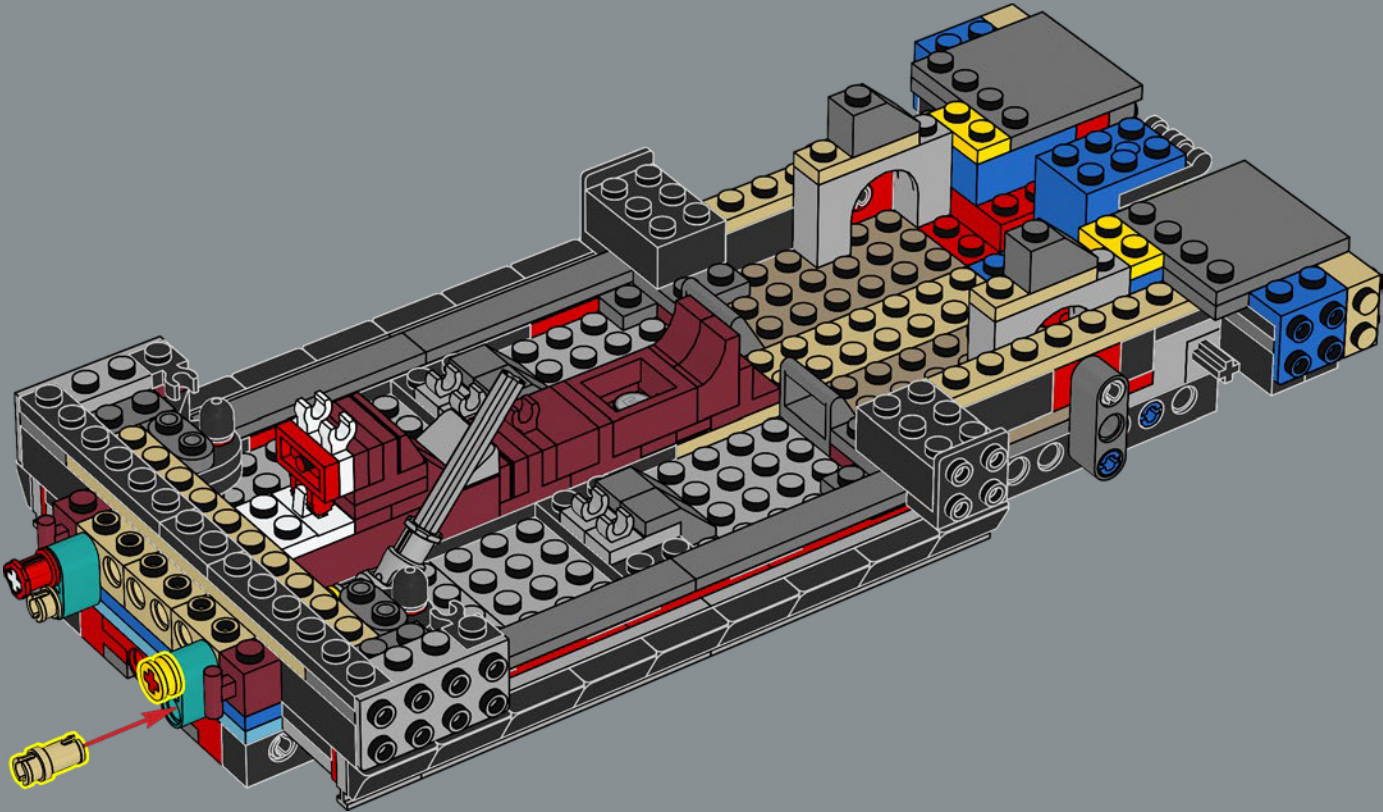

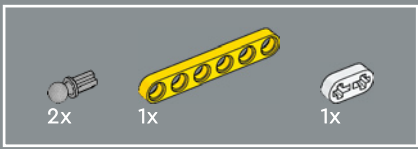

54

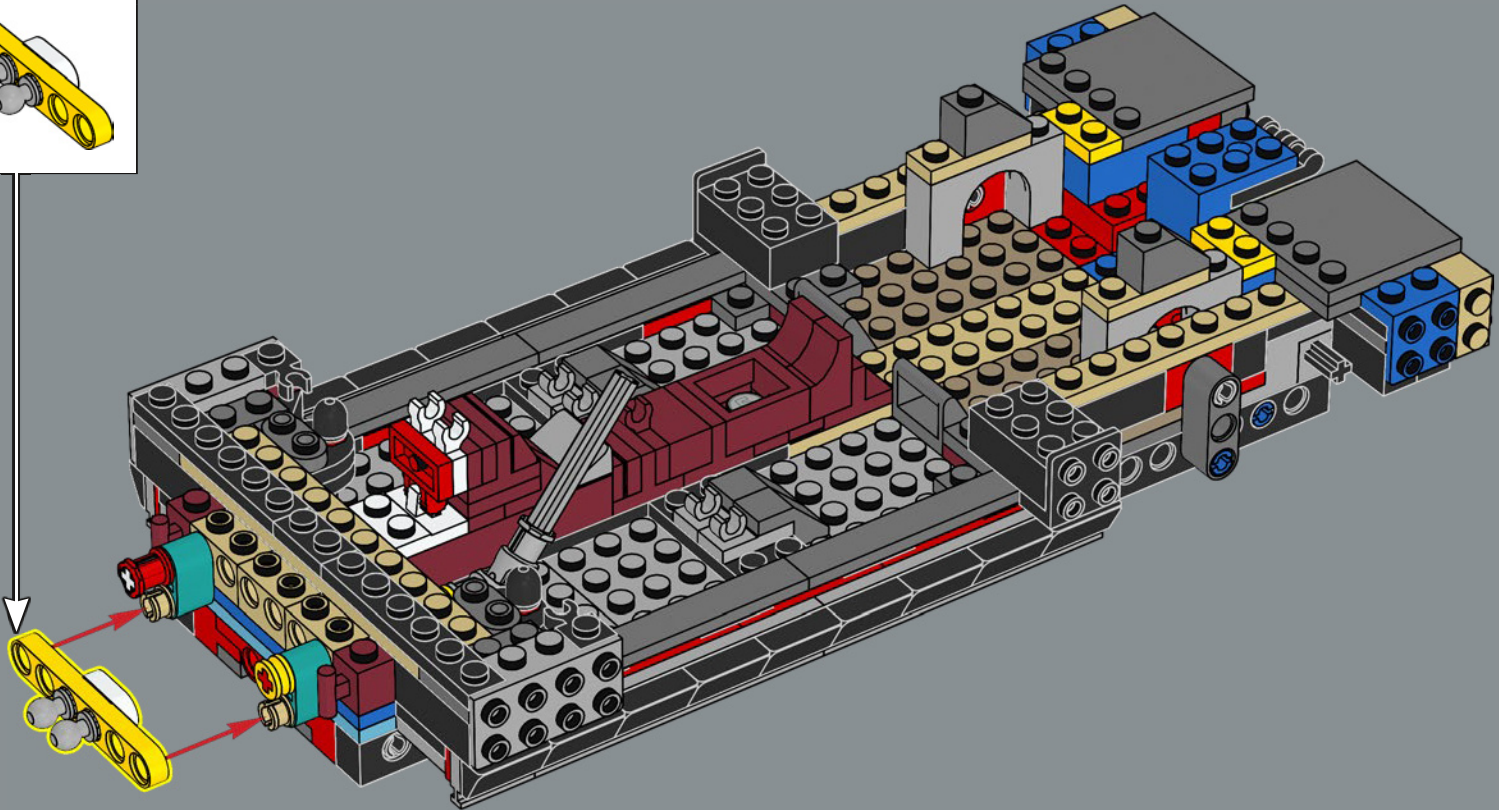
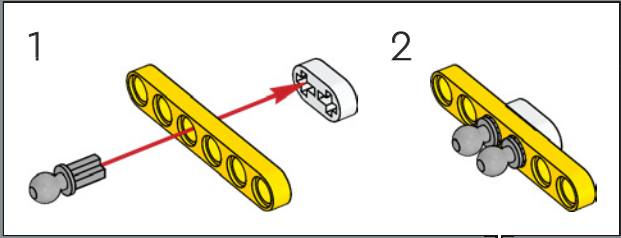

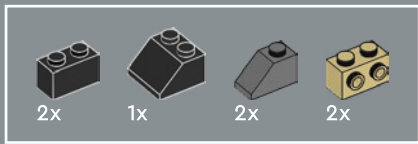

55

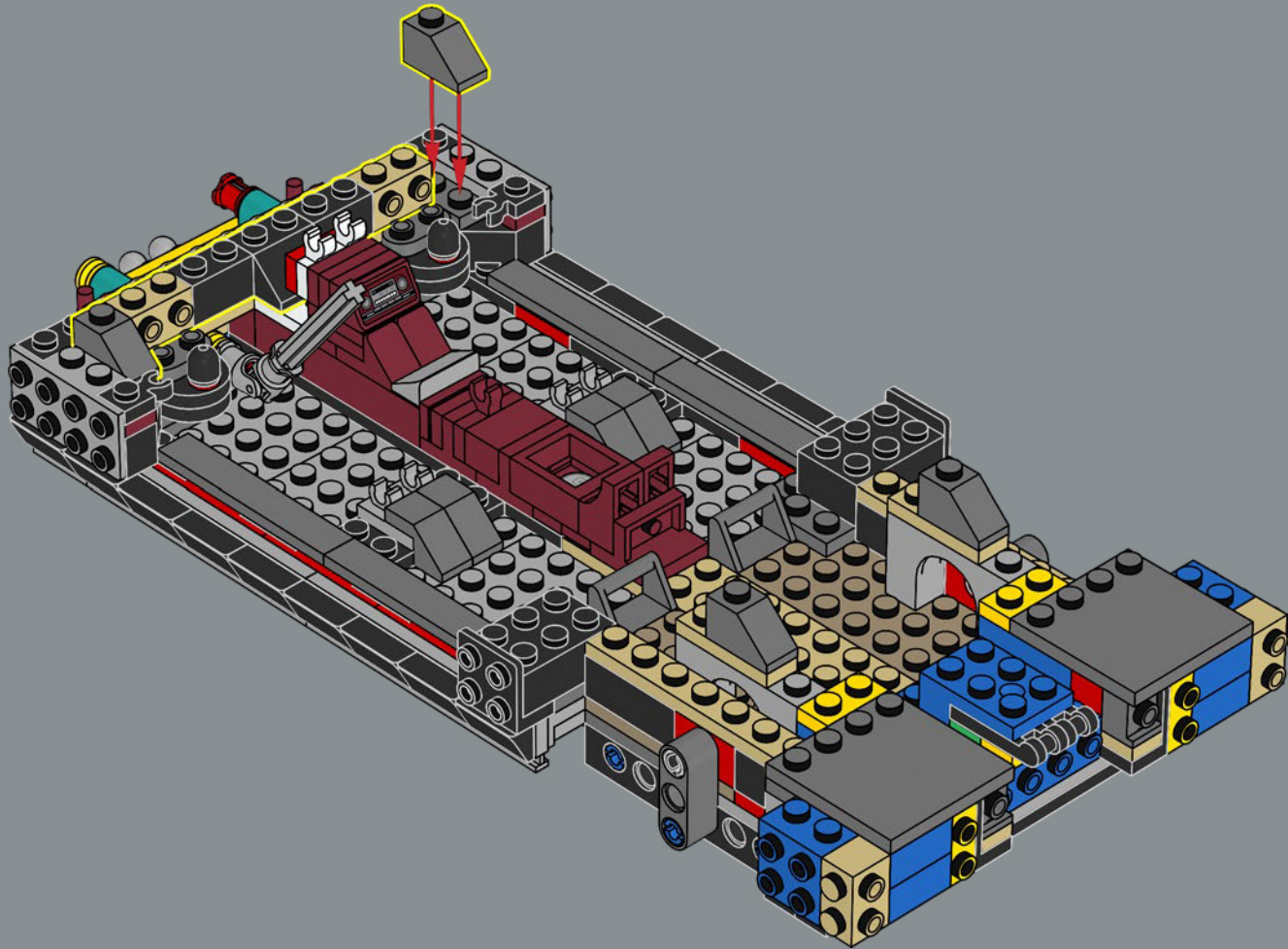

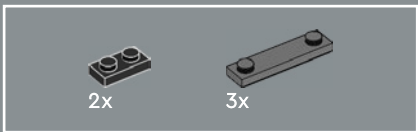

56

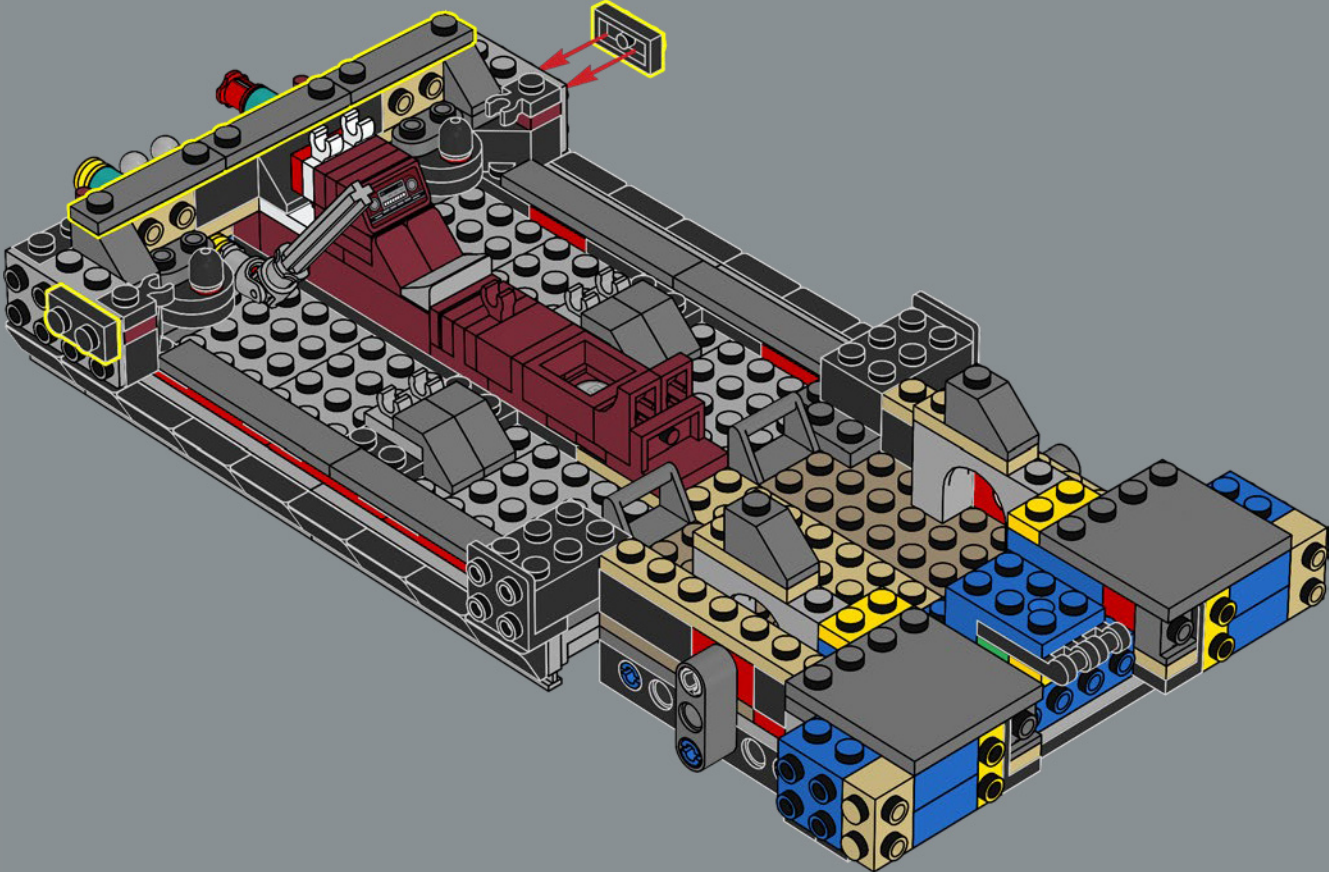

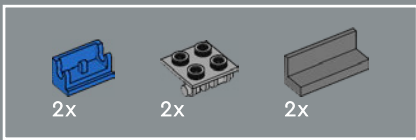

57

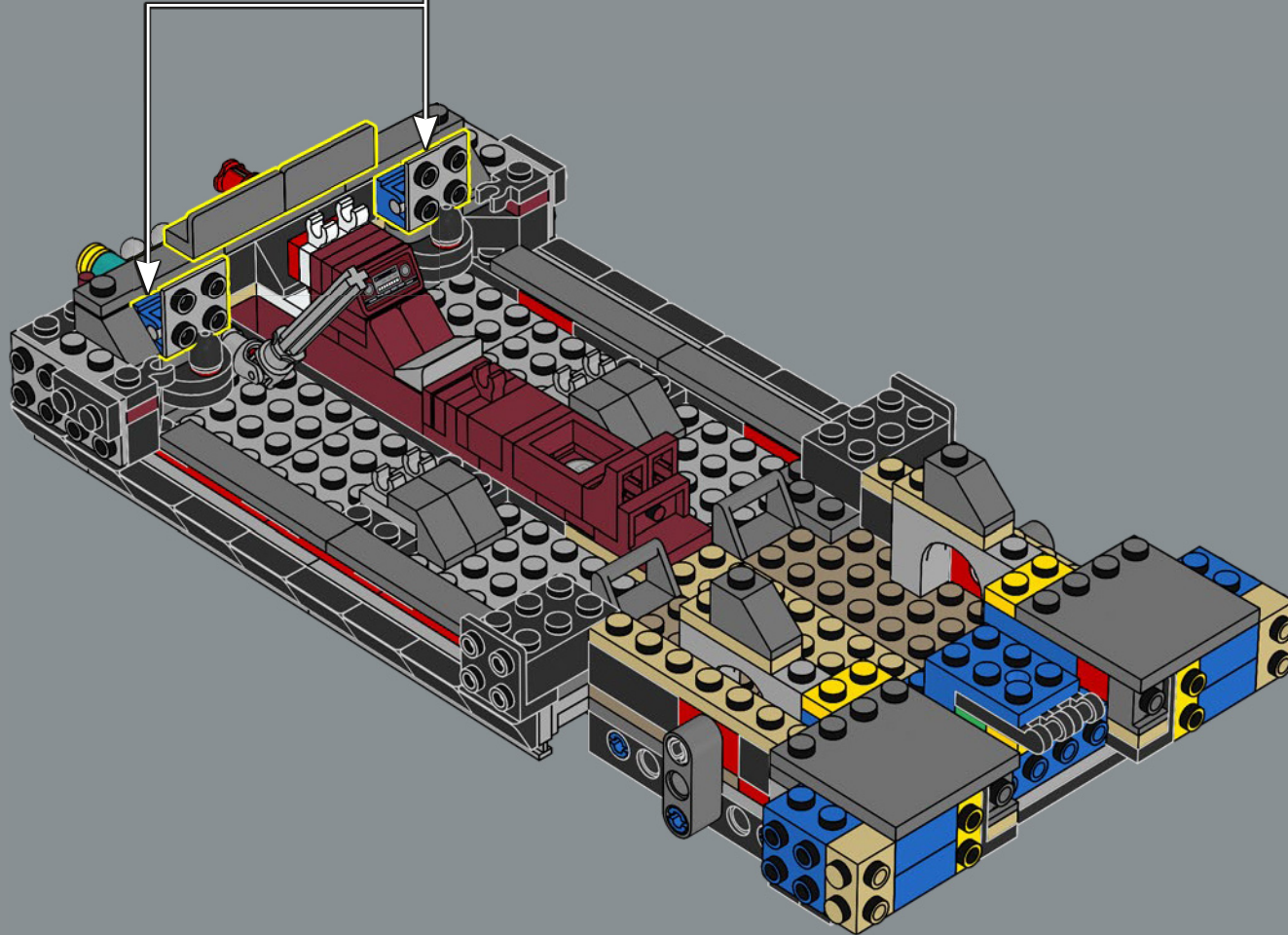
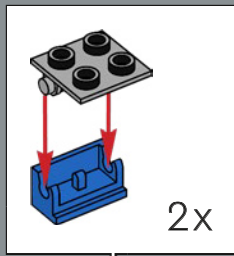



58

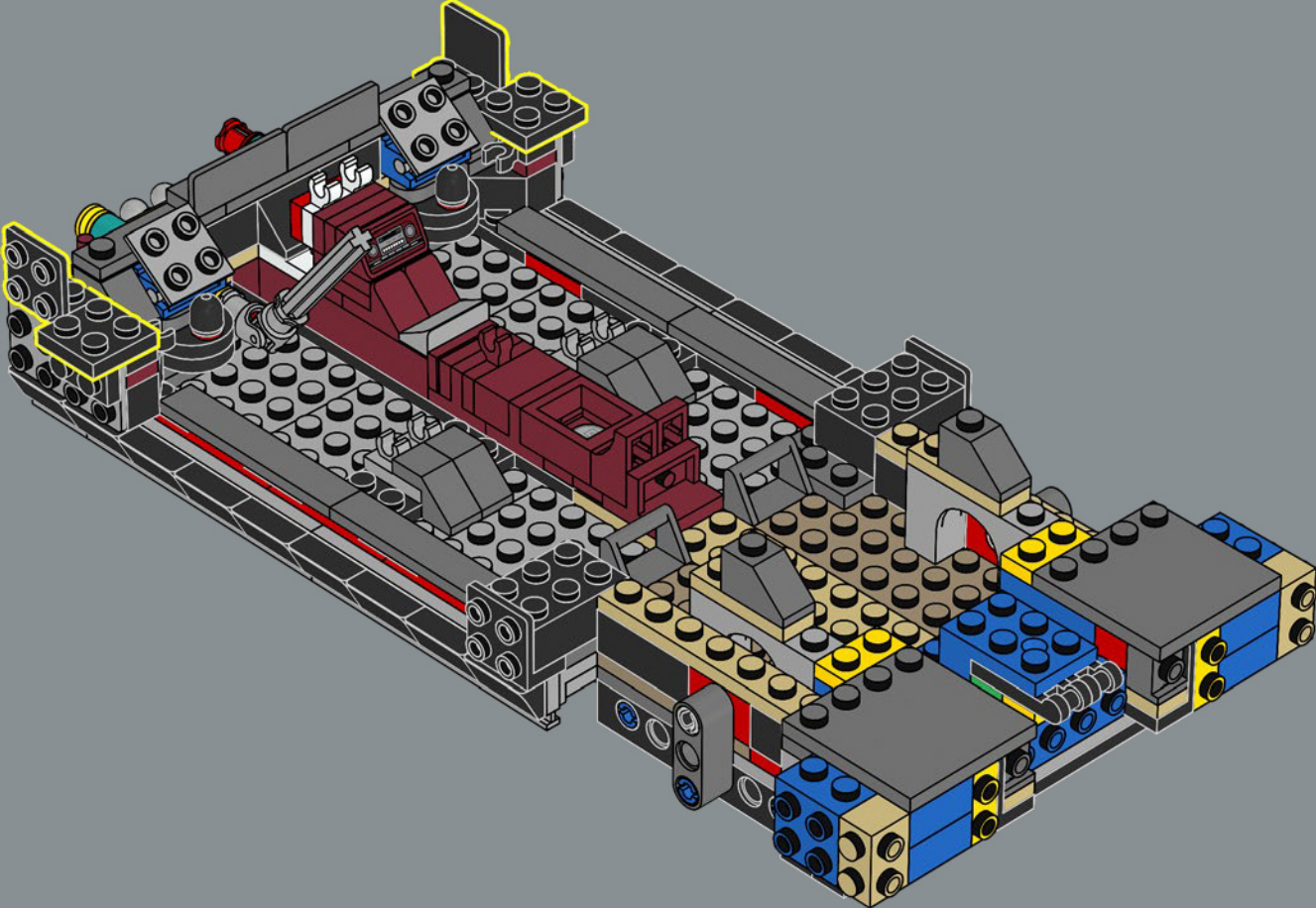

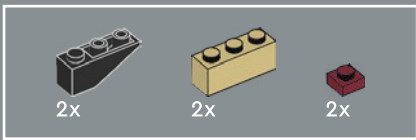

59

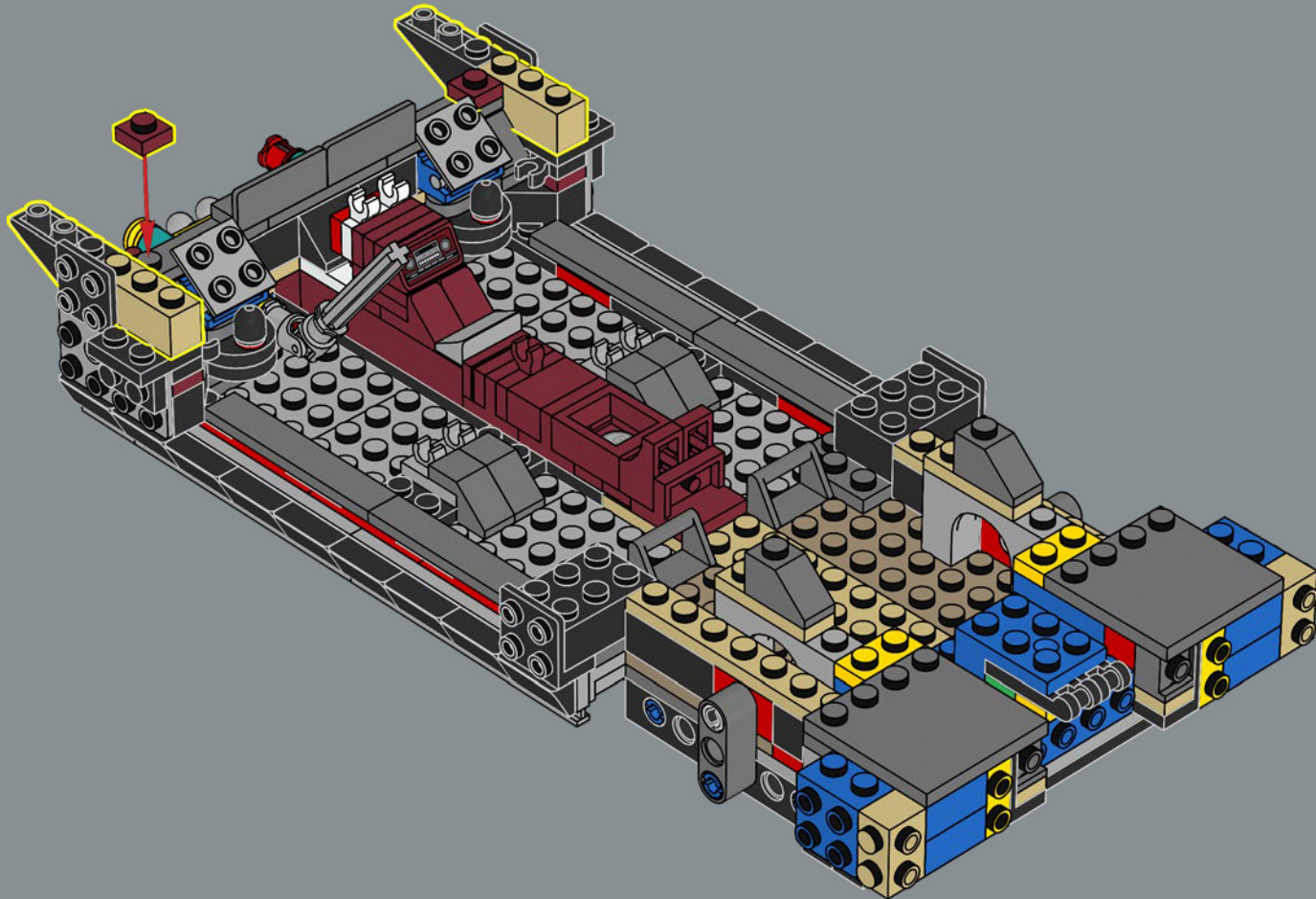



60

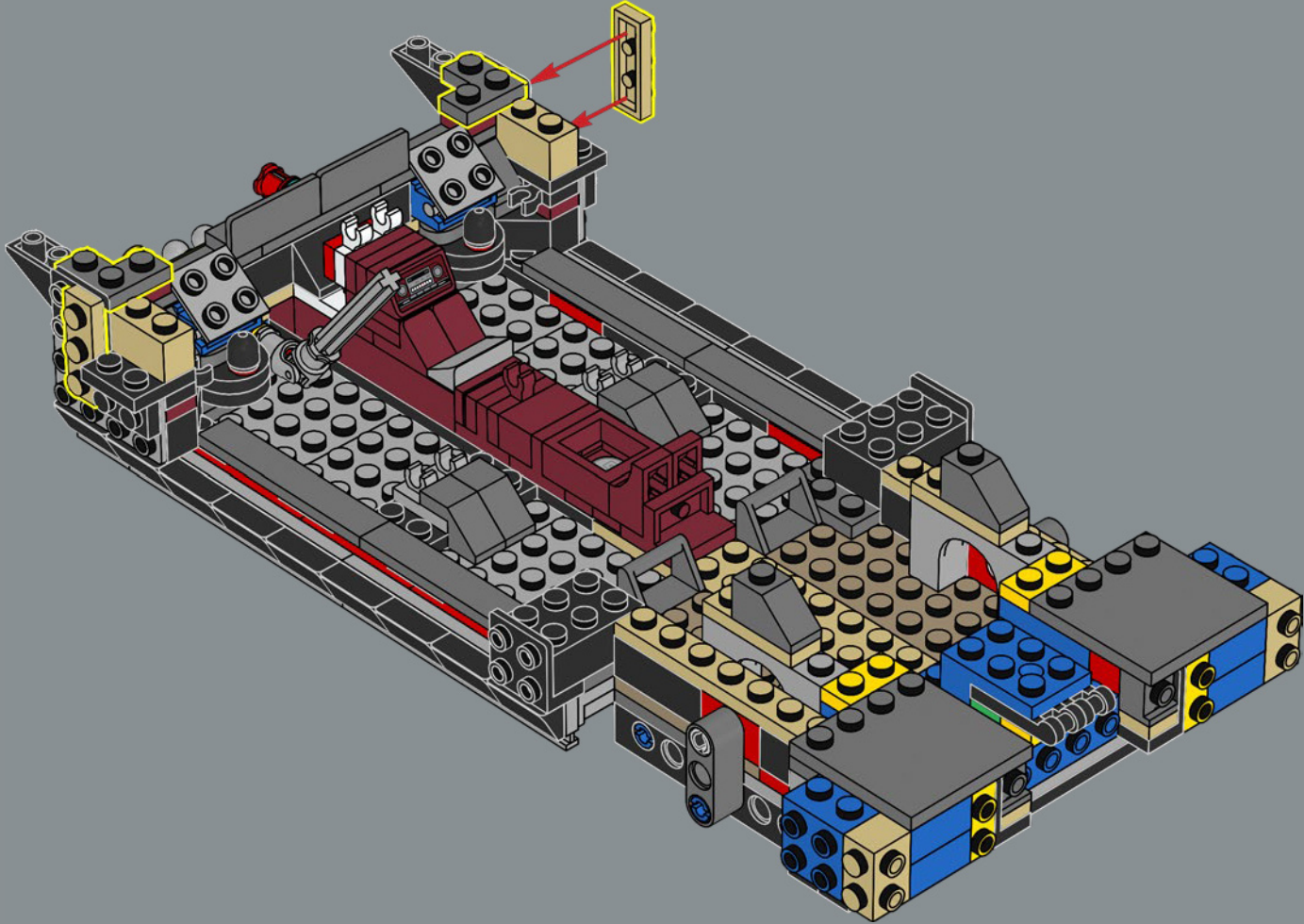

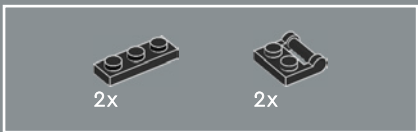

61

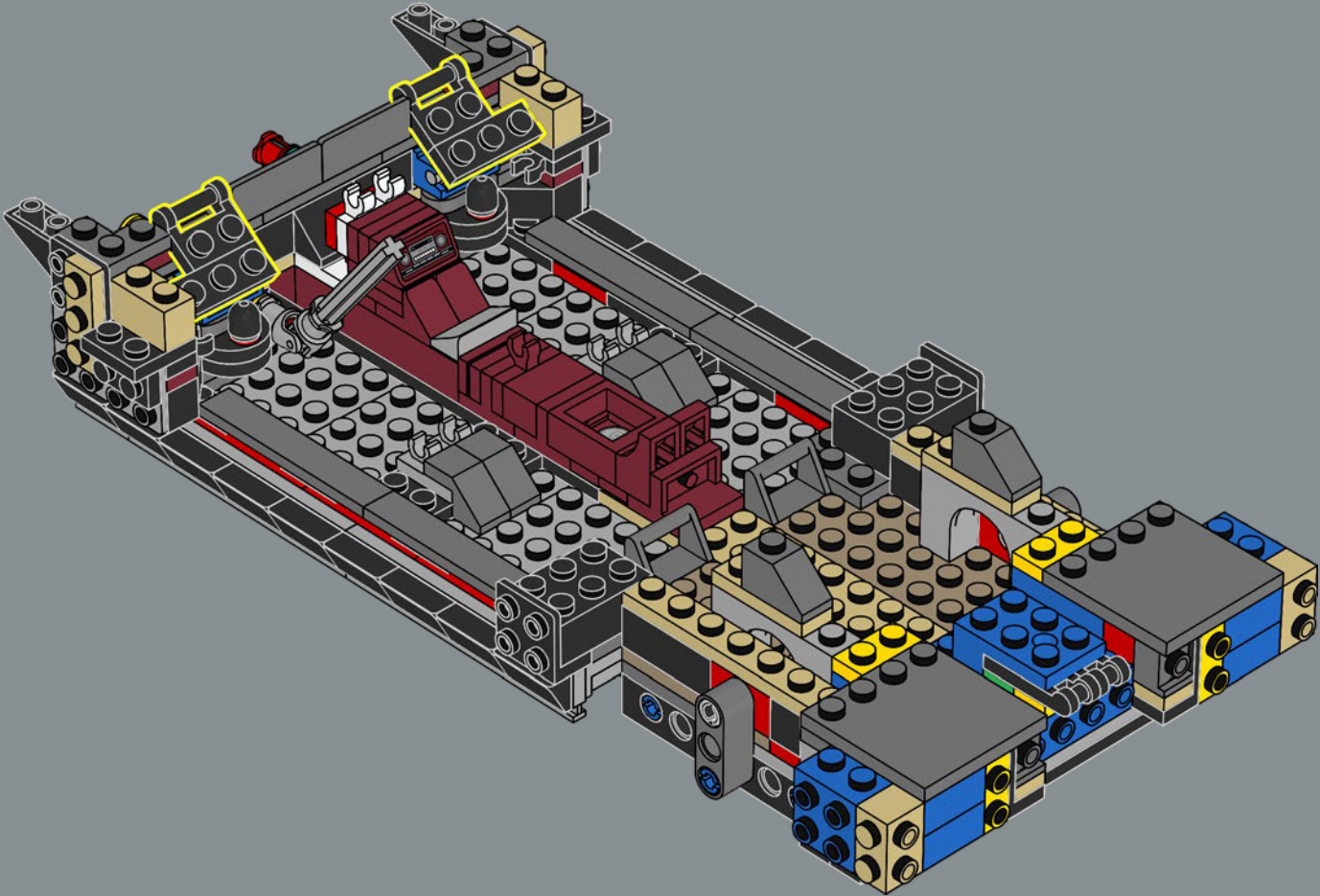

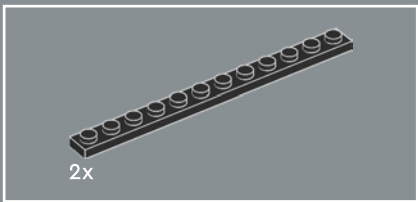

62

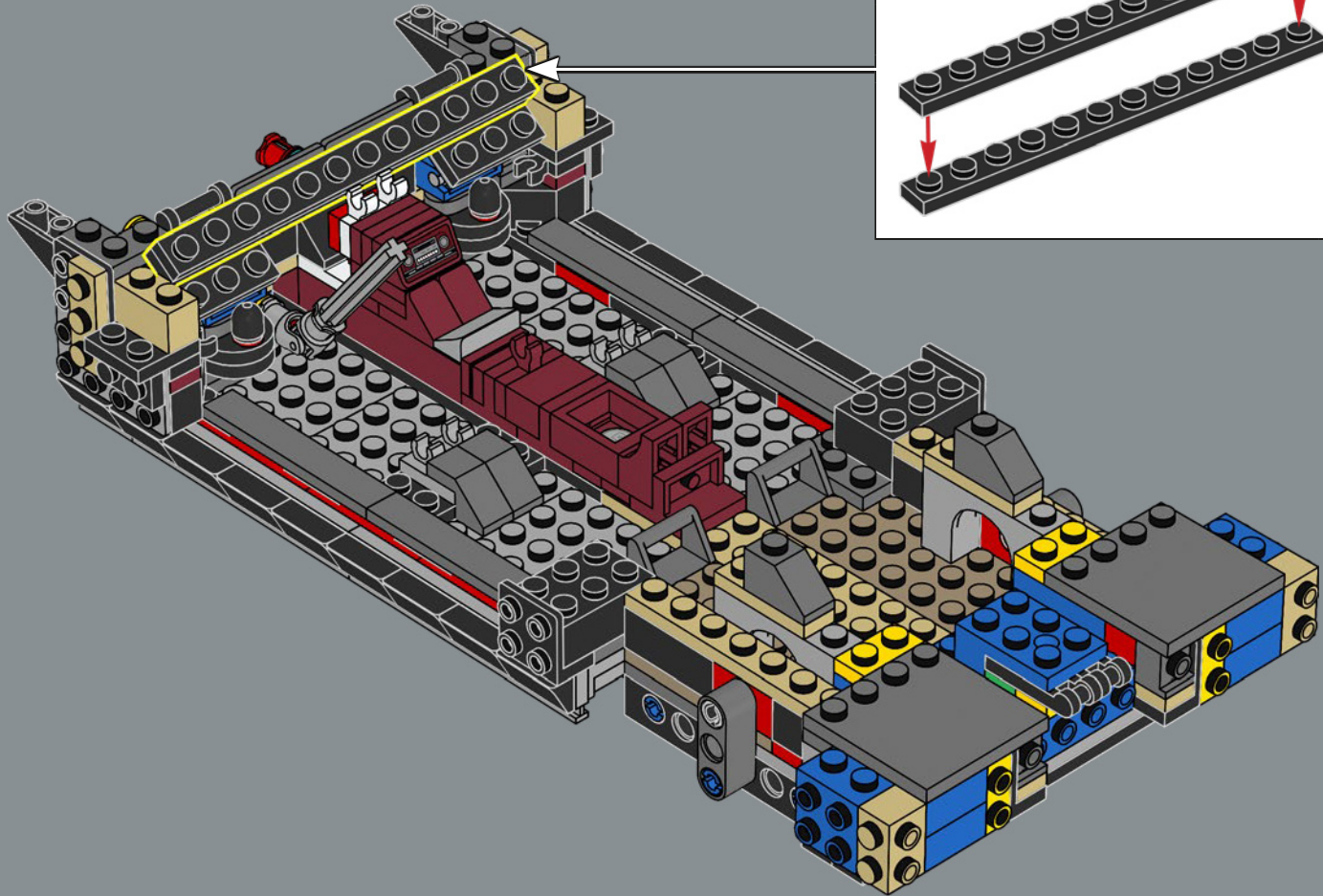

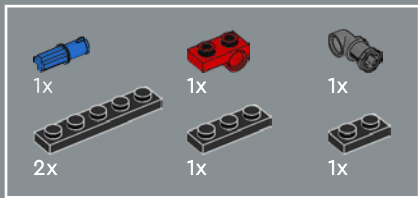

63

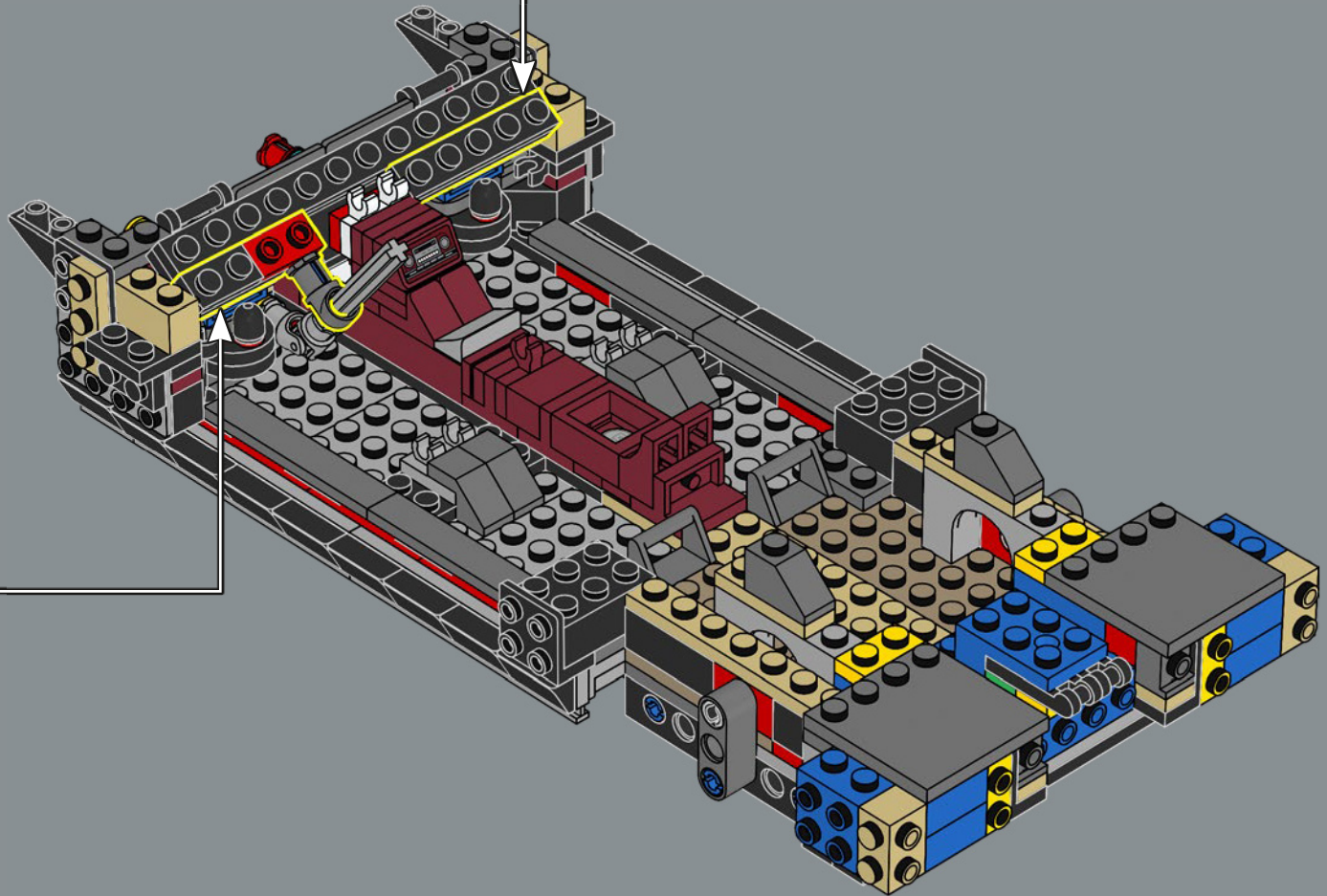
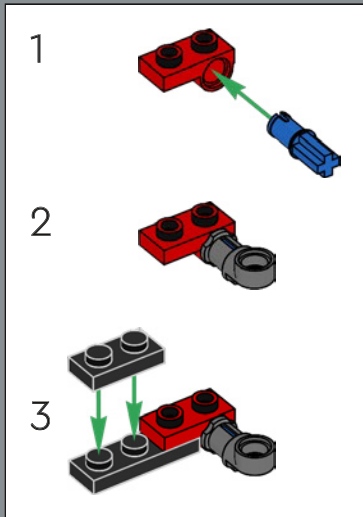
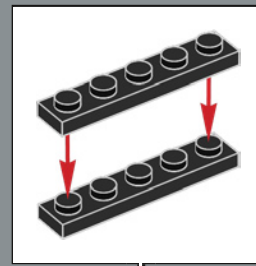

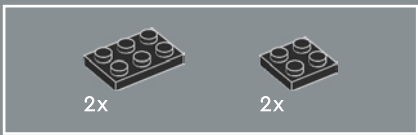

64

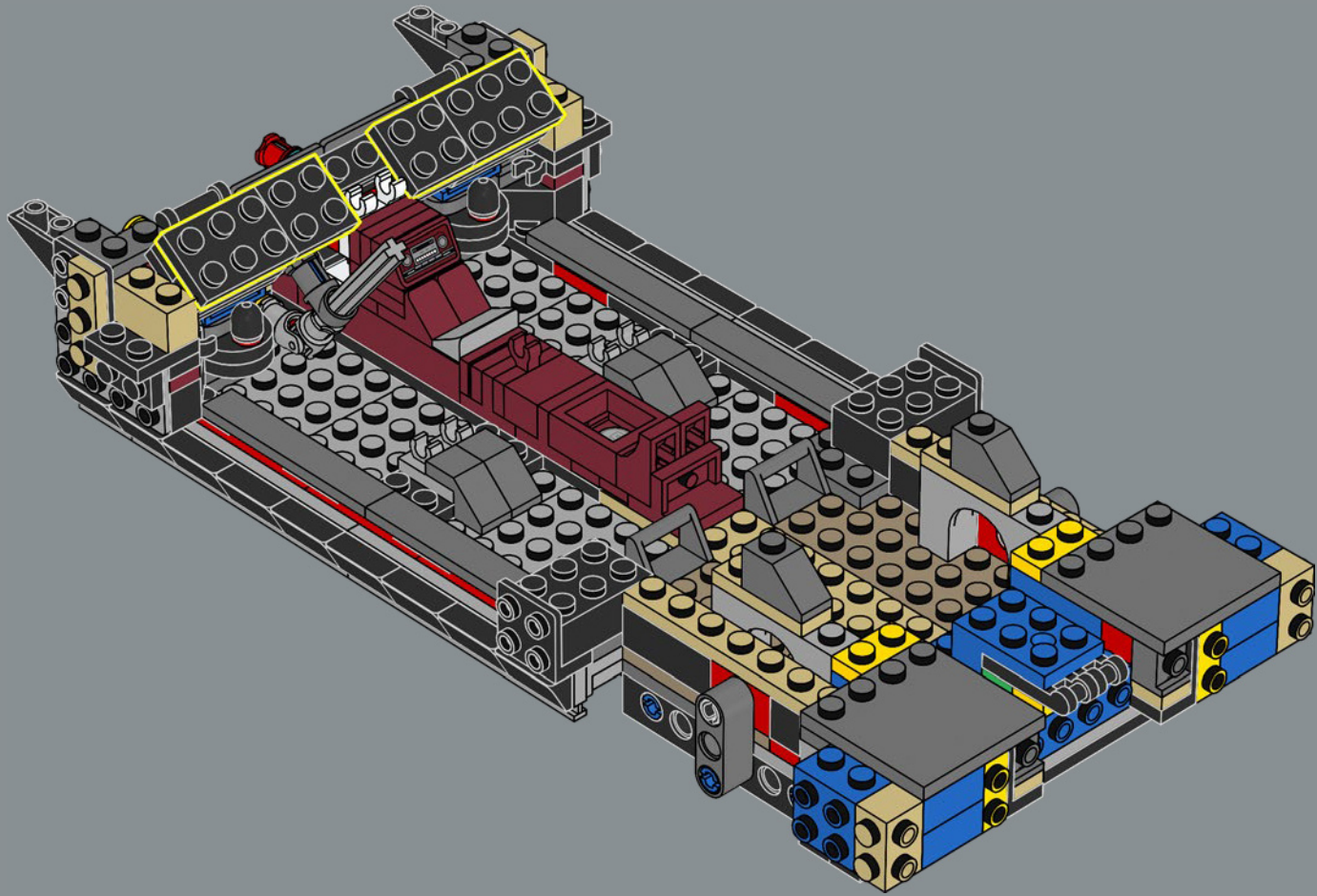



65

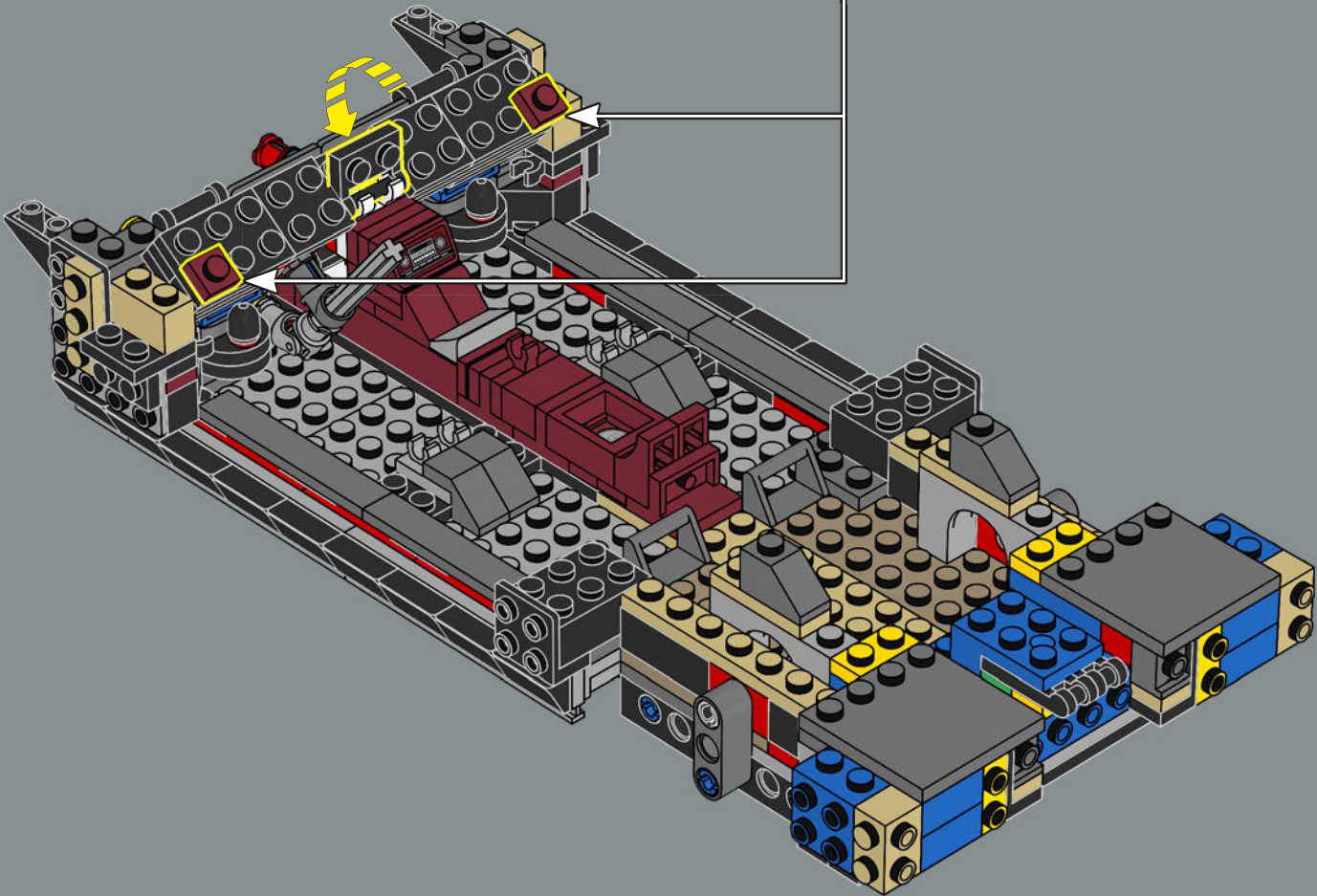
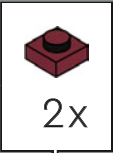

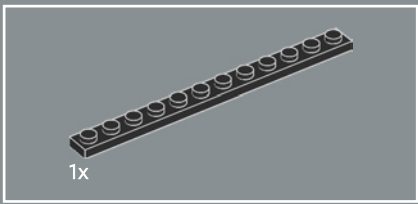

66

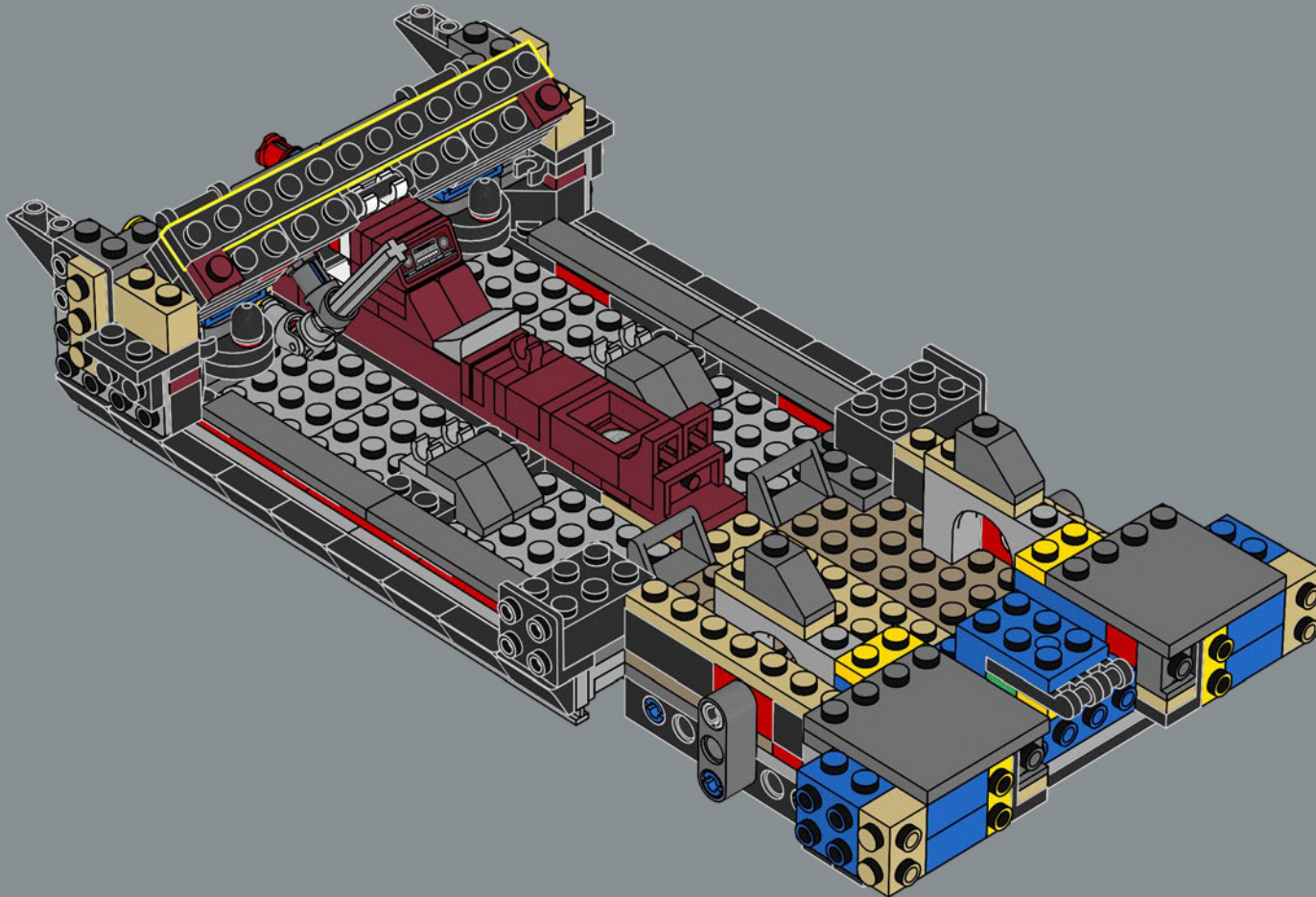

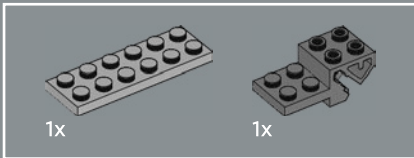
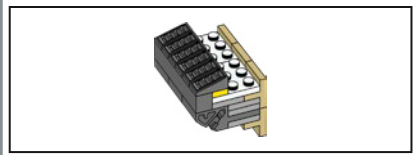

67

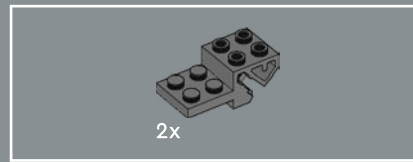
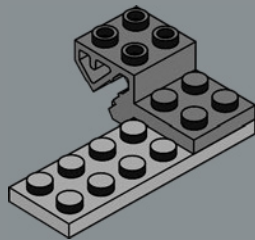

68

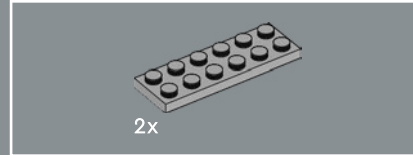
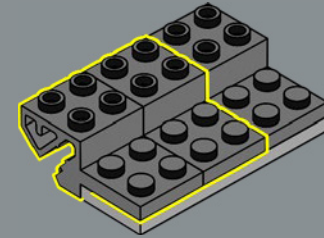

69

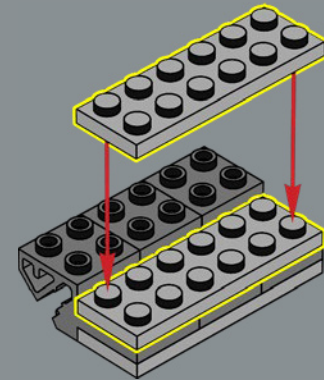

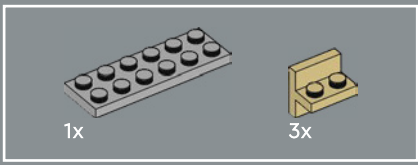

70

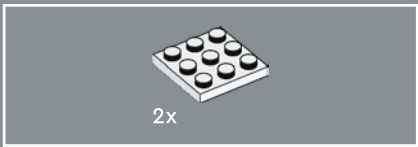
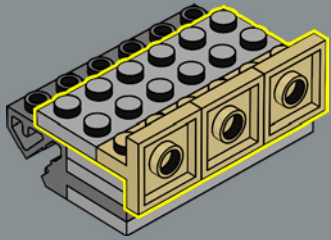

71

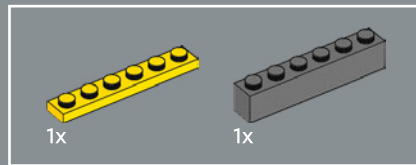
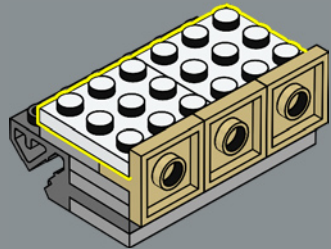

72

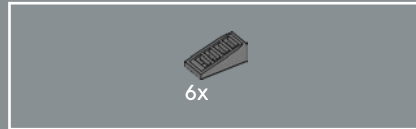
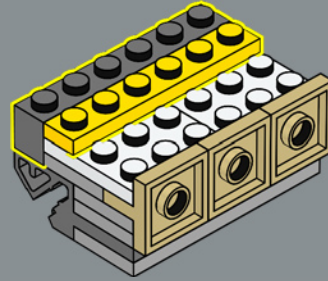

73

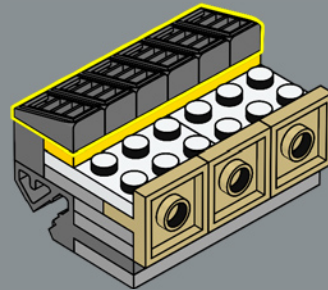

74

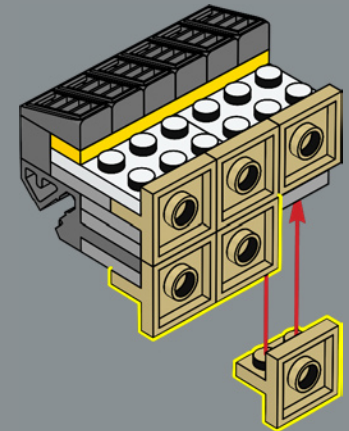

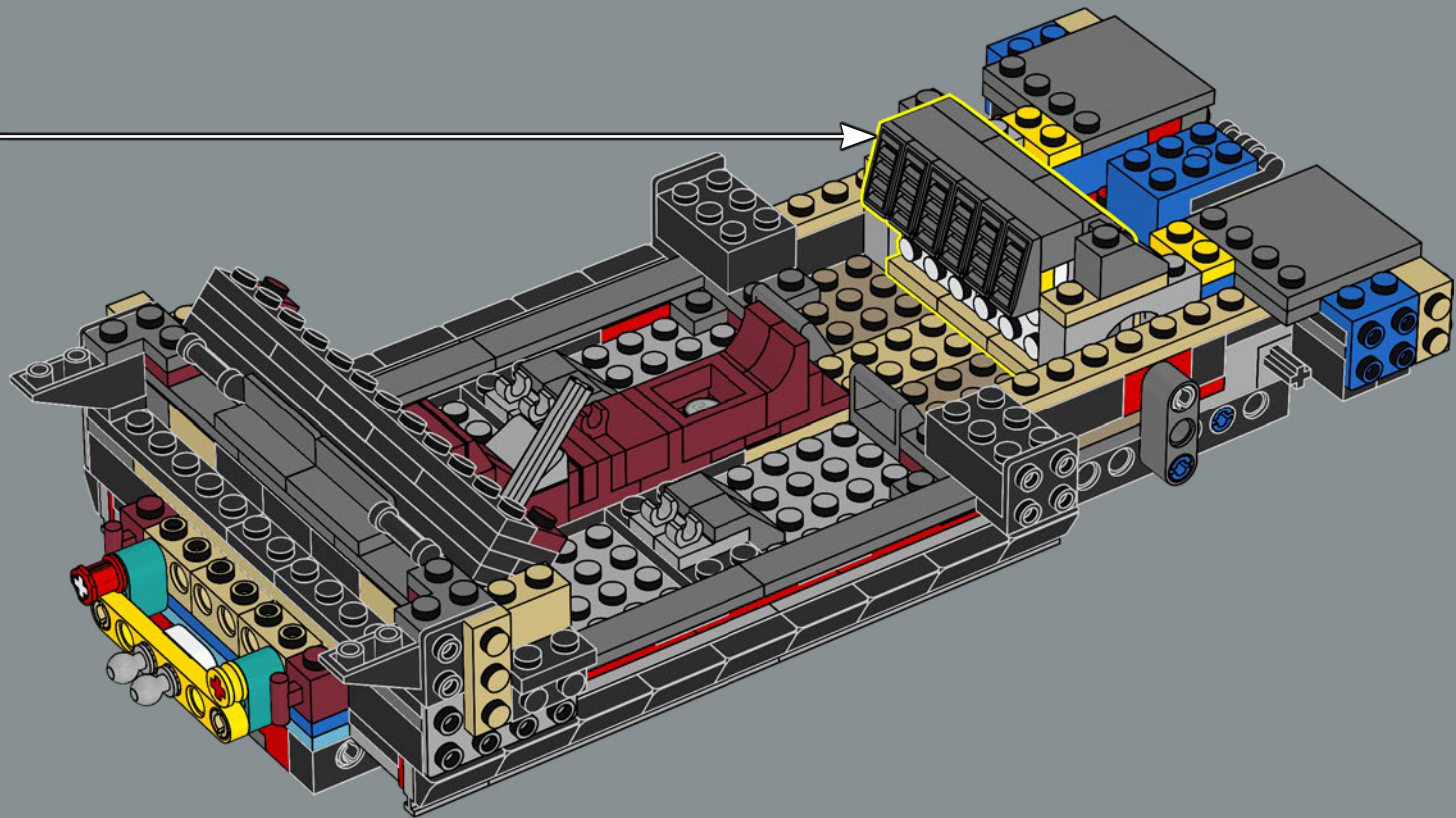

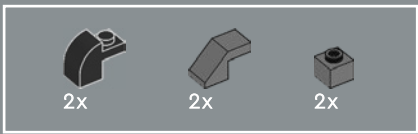

76

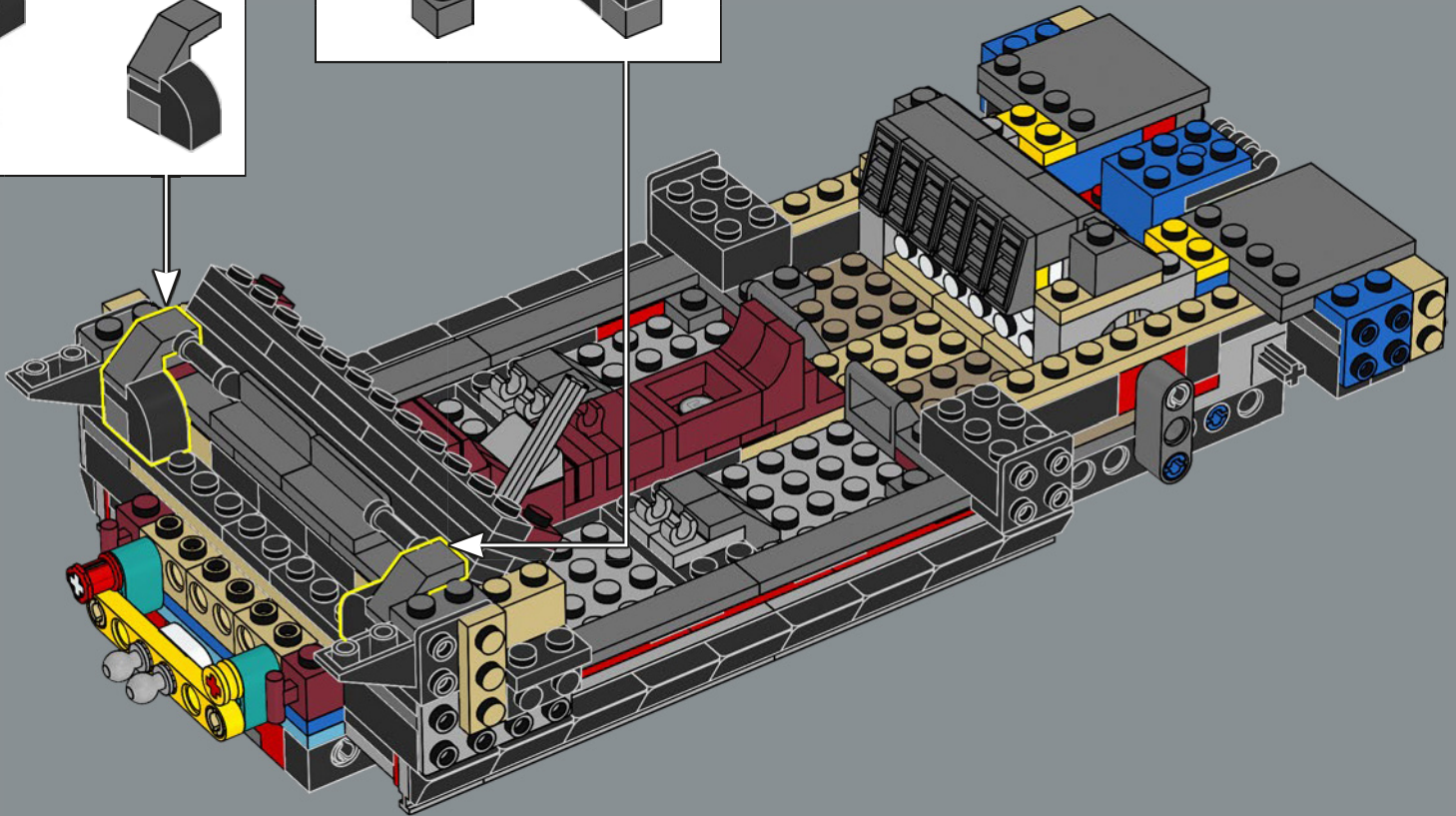
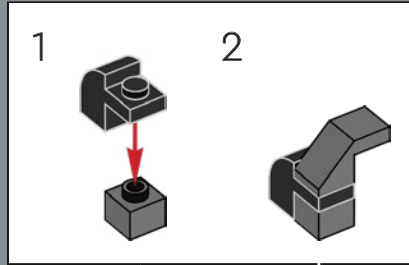
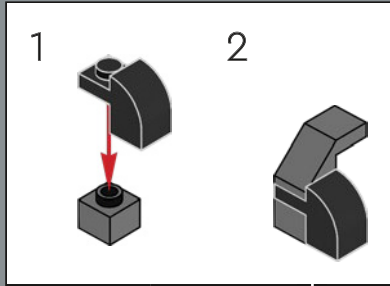

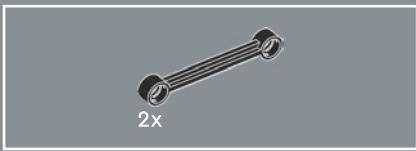

Una speciale Camaro Z11 cabriolet è stata la "pace car" ufficiale della 500 Miglia di Indianapolis nel 1969.

77

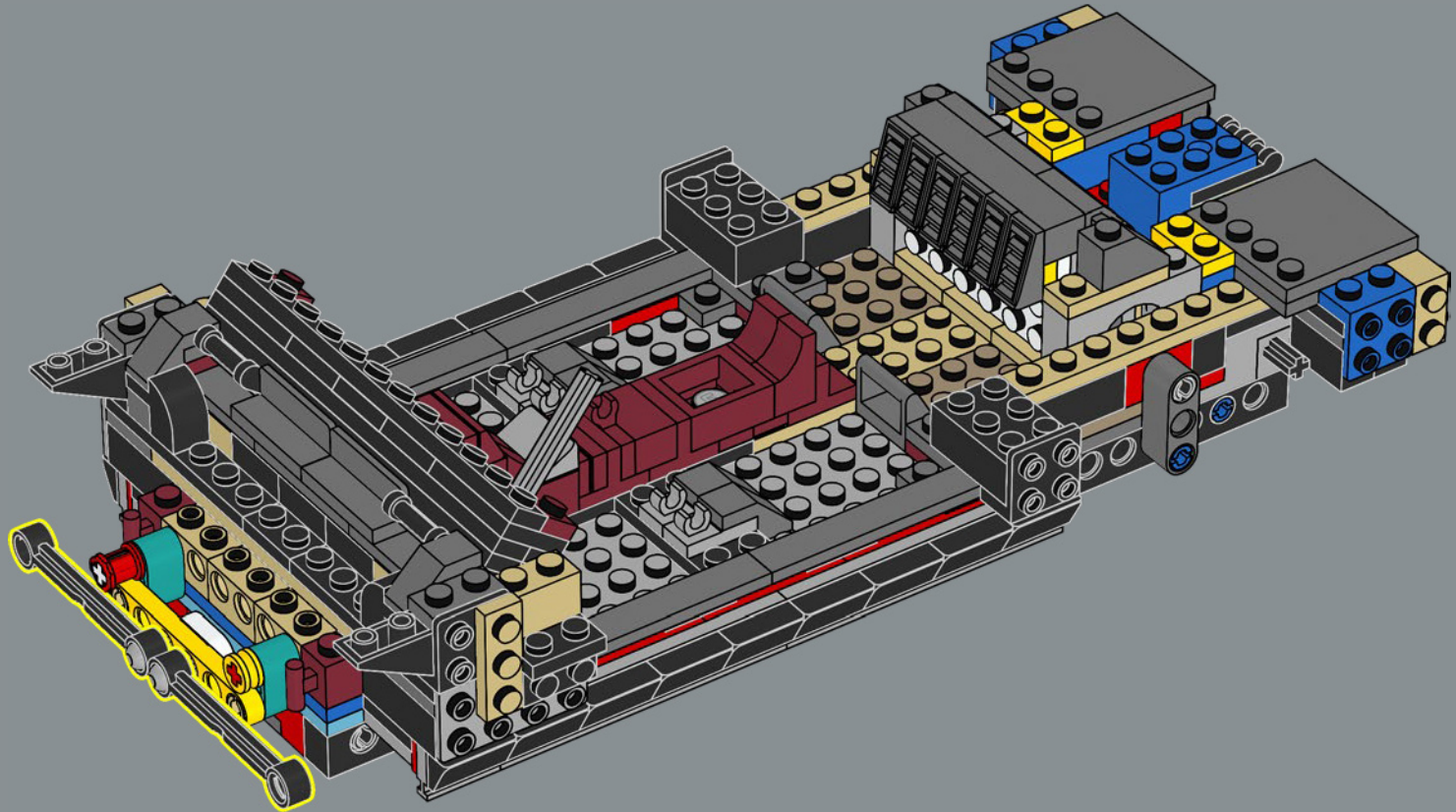

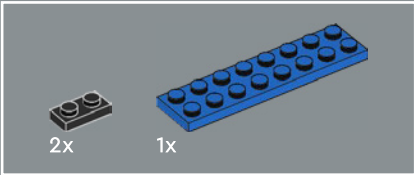
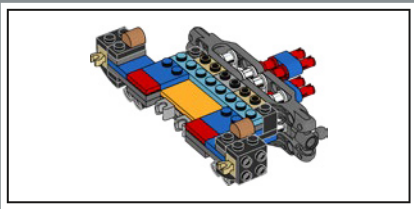

78

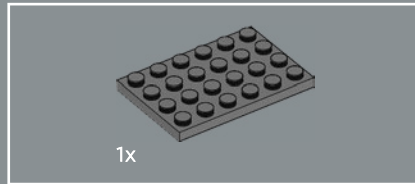
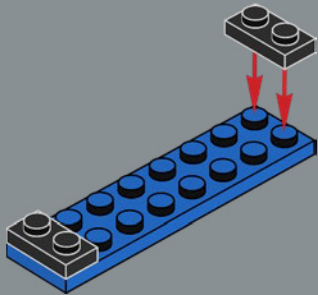

79

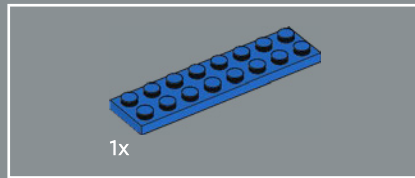
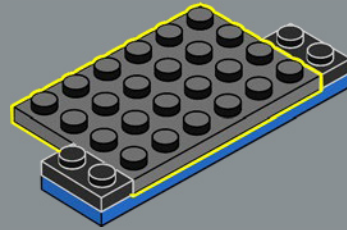

80

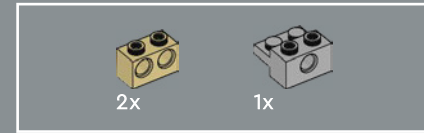
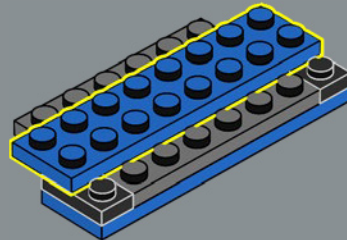

81

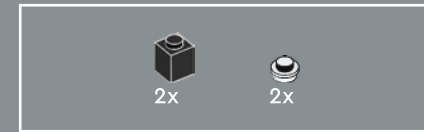
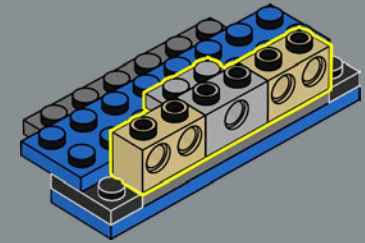

82

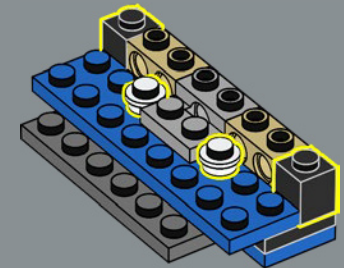



83

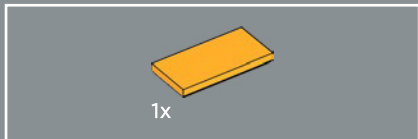
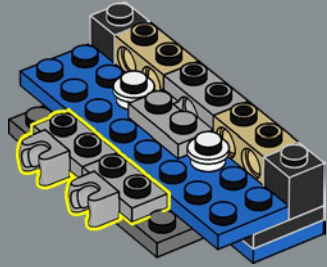

84

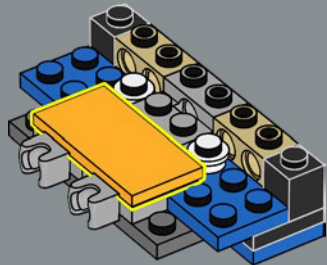

85

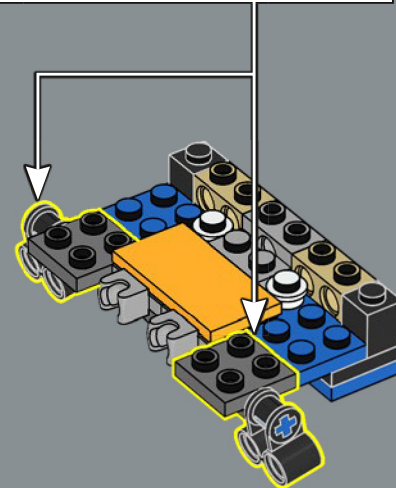
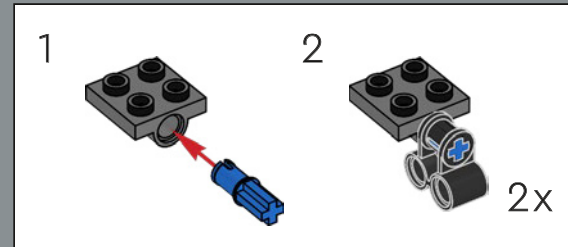

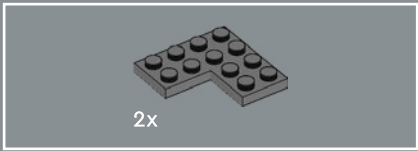

86

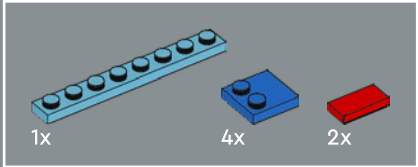
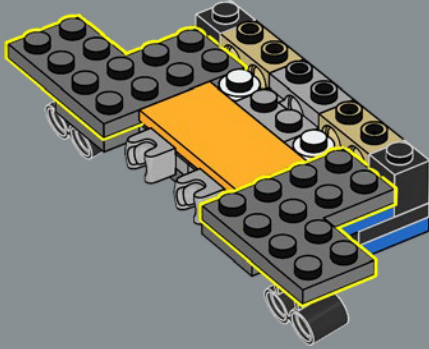

87

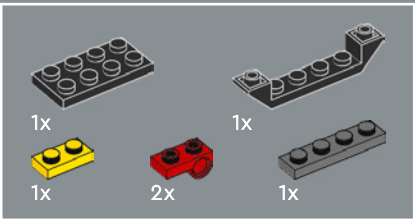
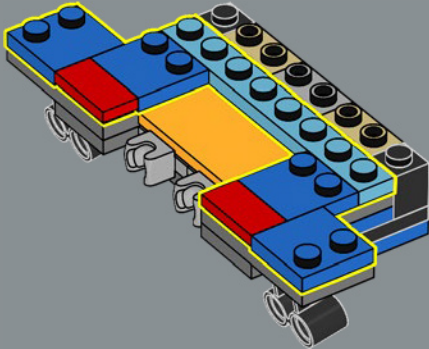

88

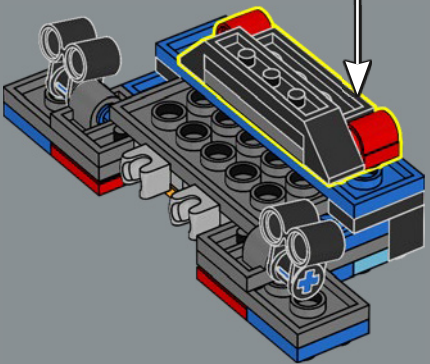
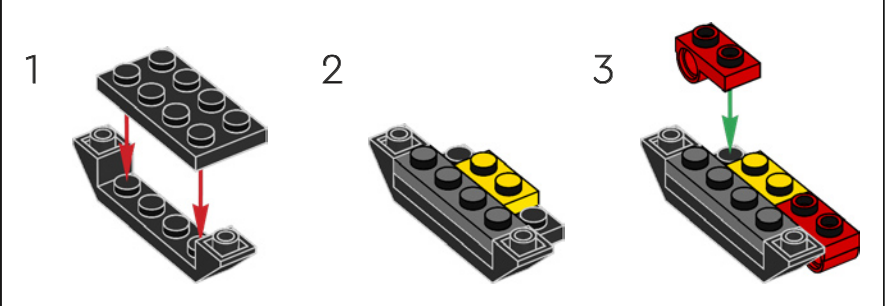

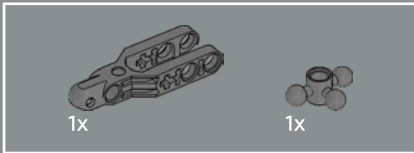
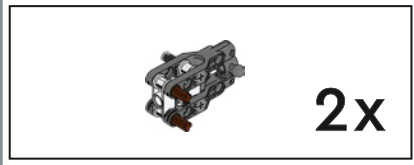
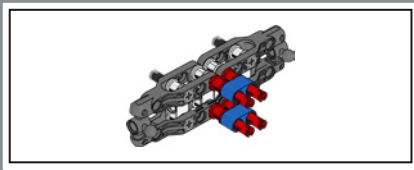

89

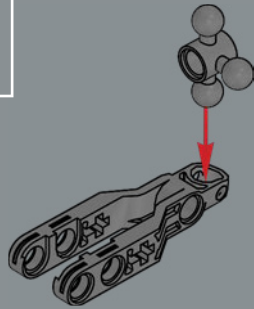

90

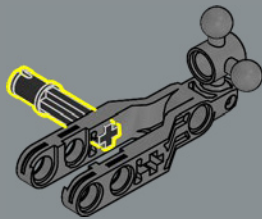

91

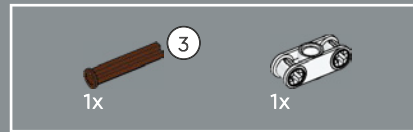
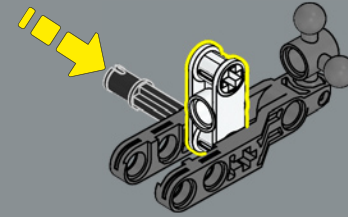

92

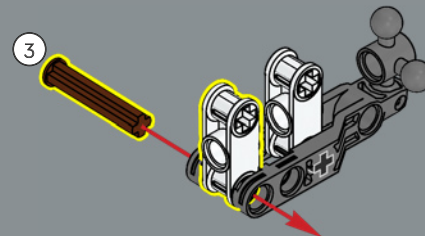



93

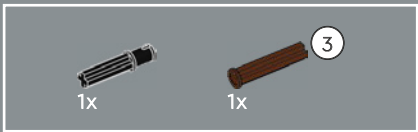
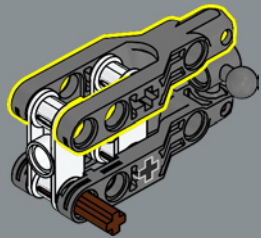

94

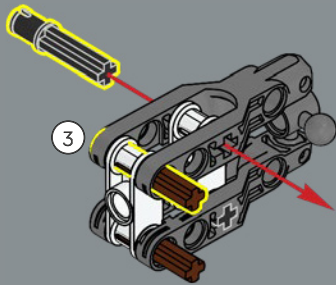

2x

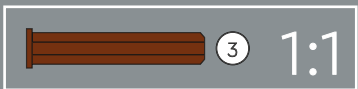

95

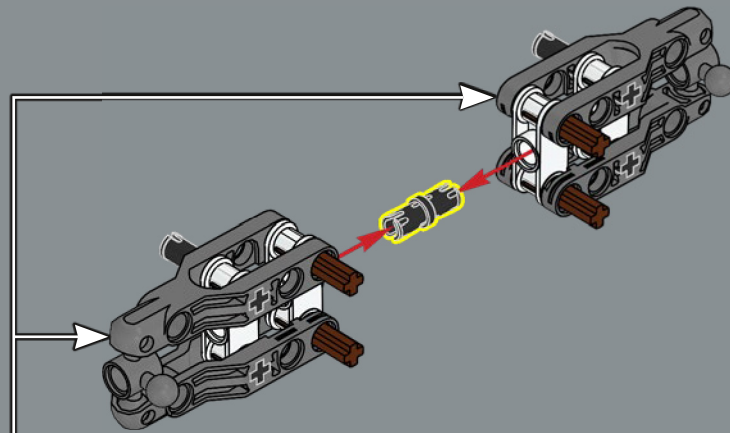



96

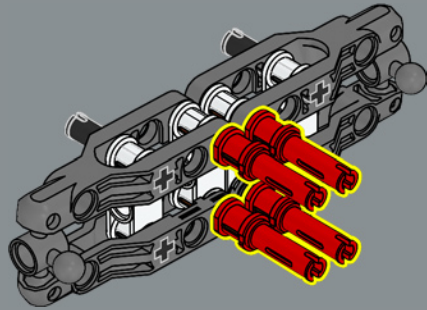

97

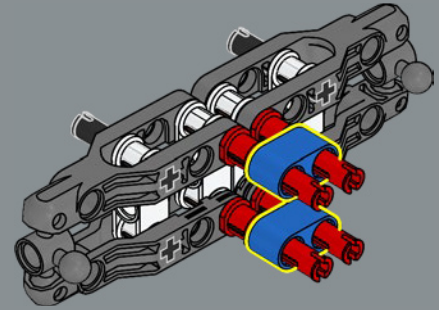

98

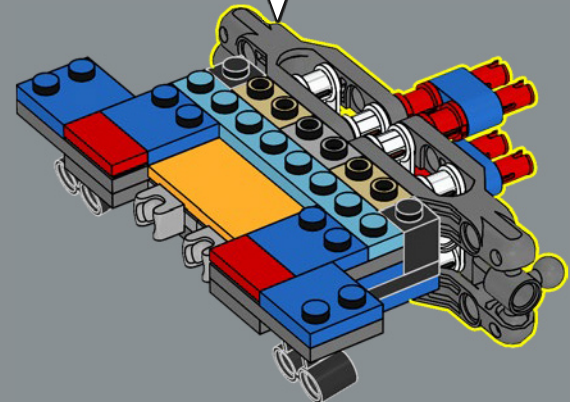

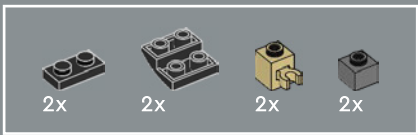

99

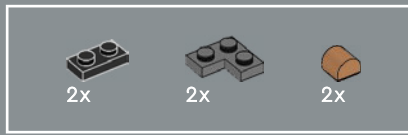
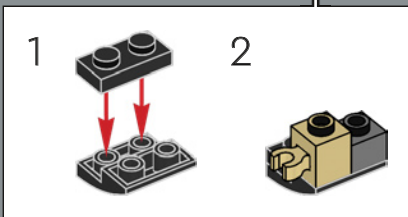
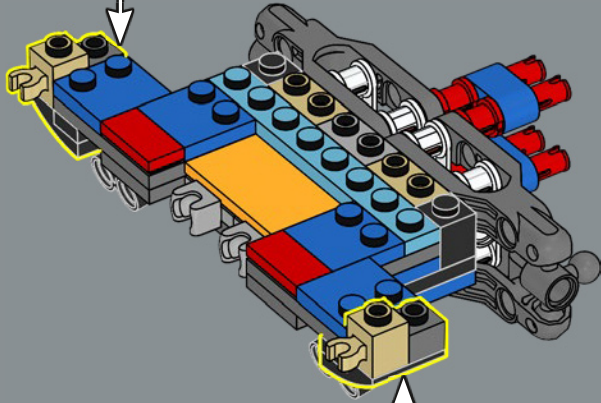
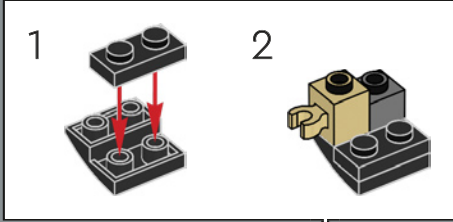

100

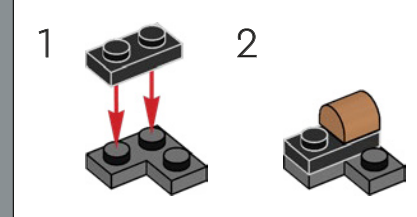
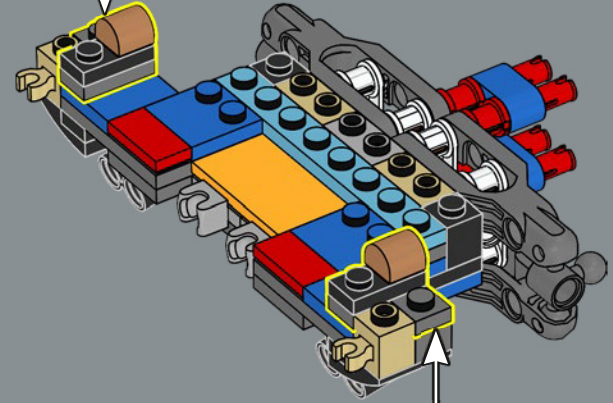
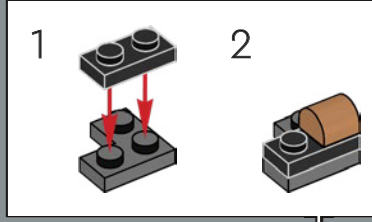



101

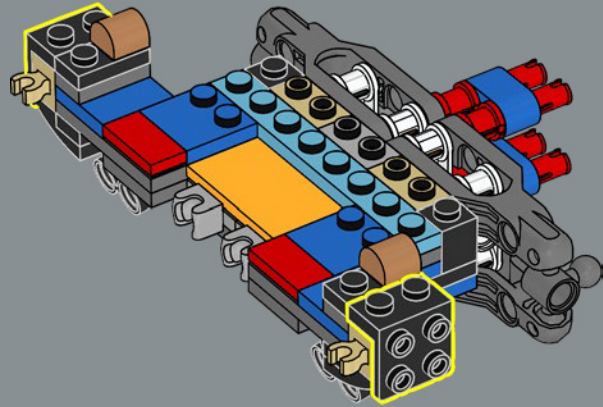

102

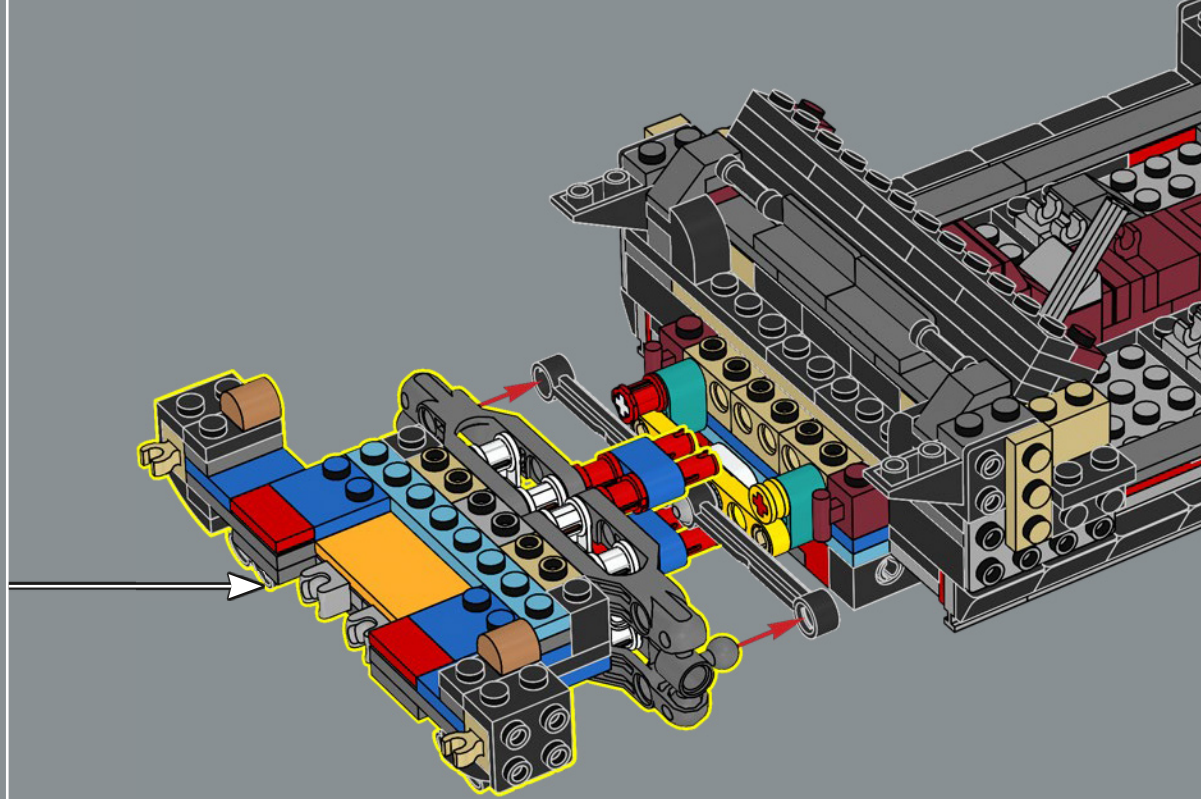

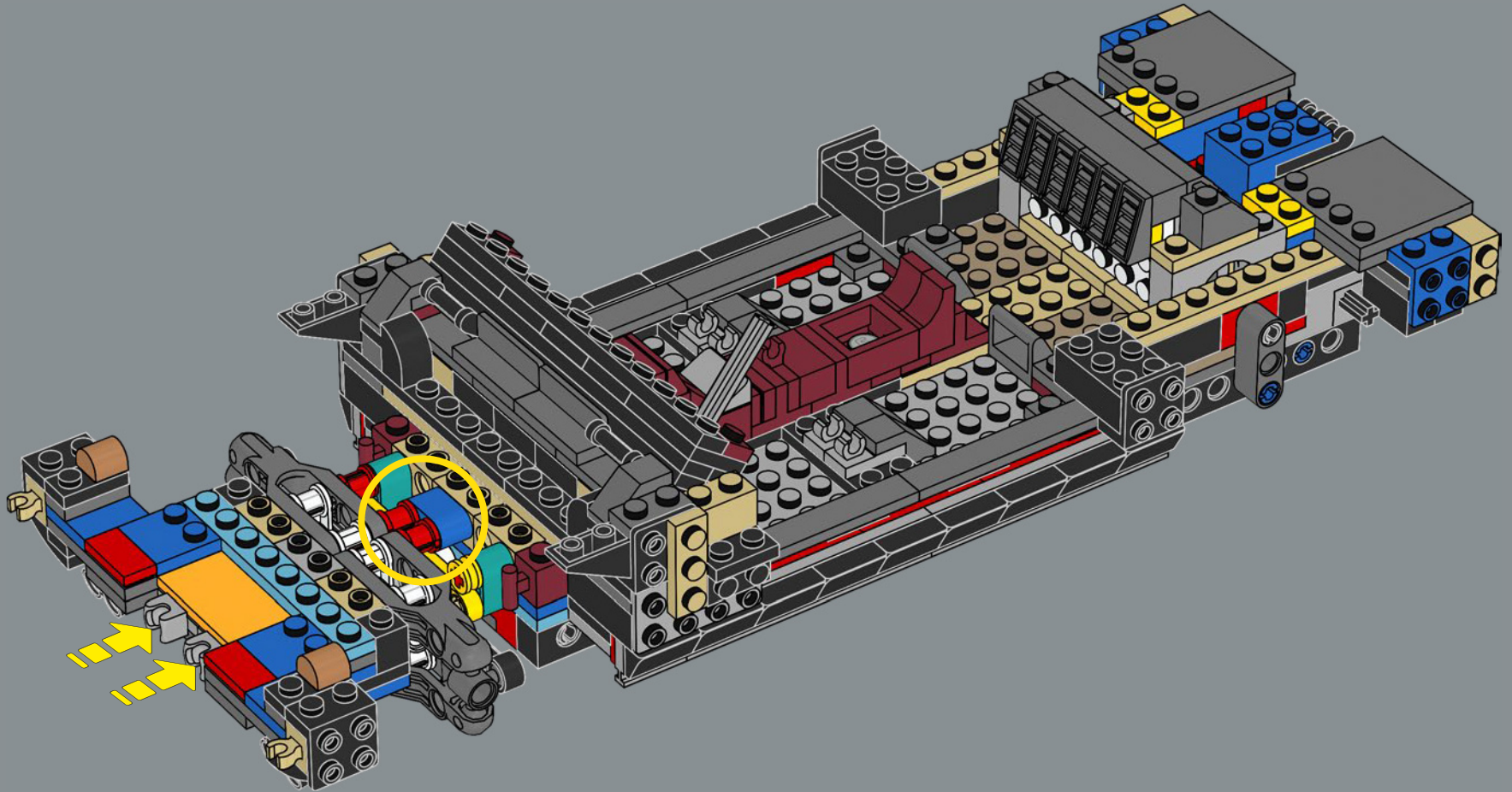

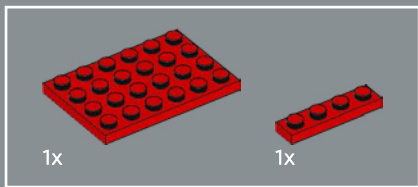

104

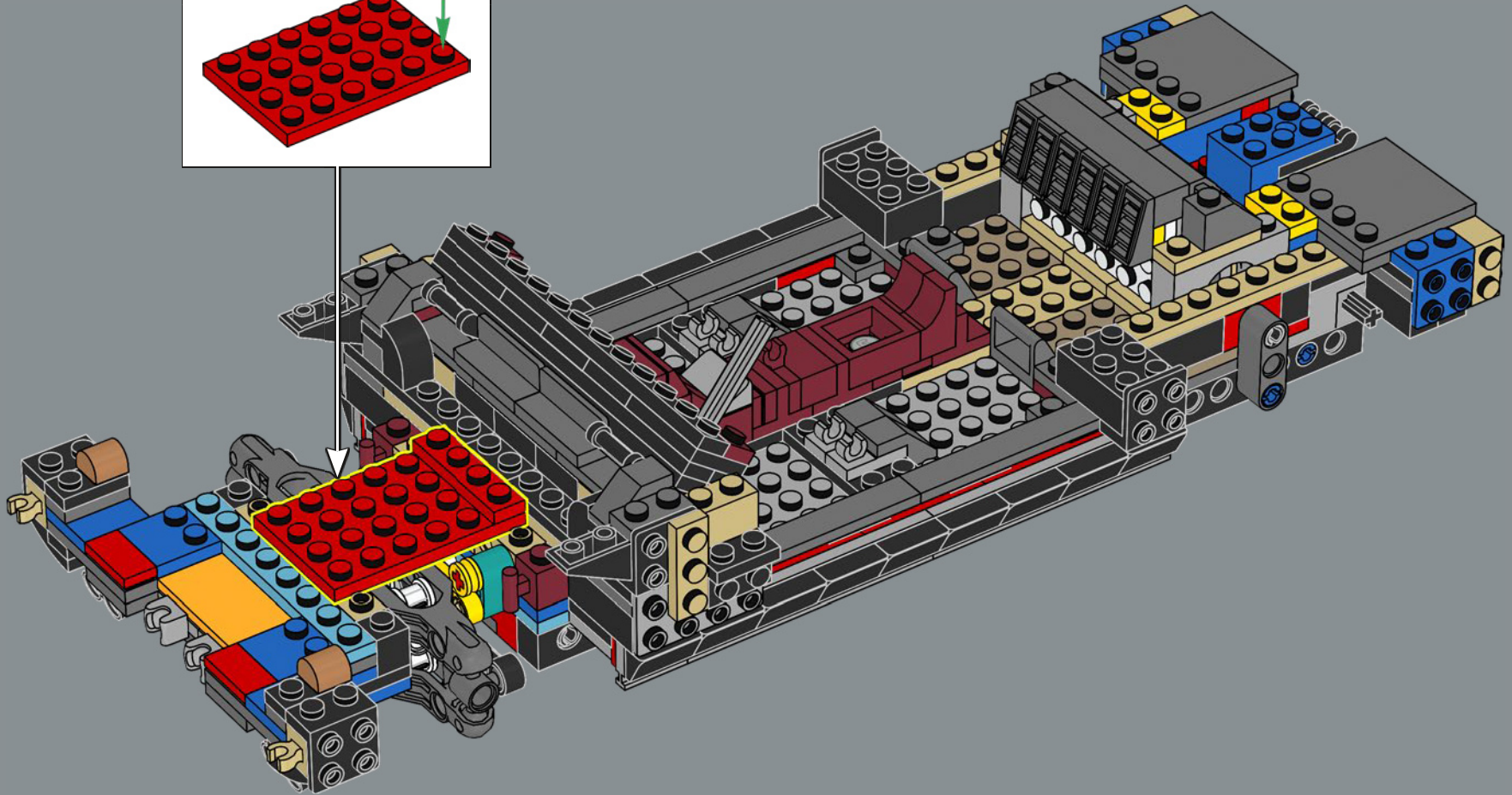
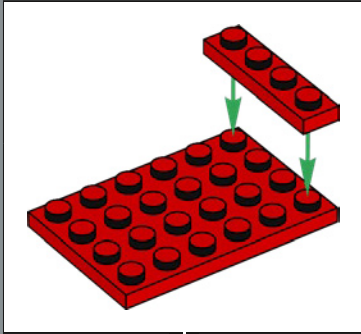

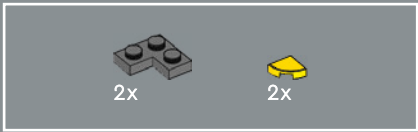

105

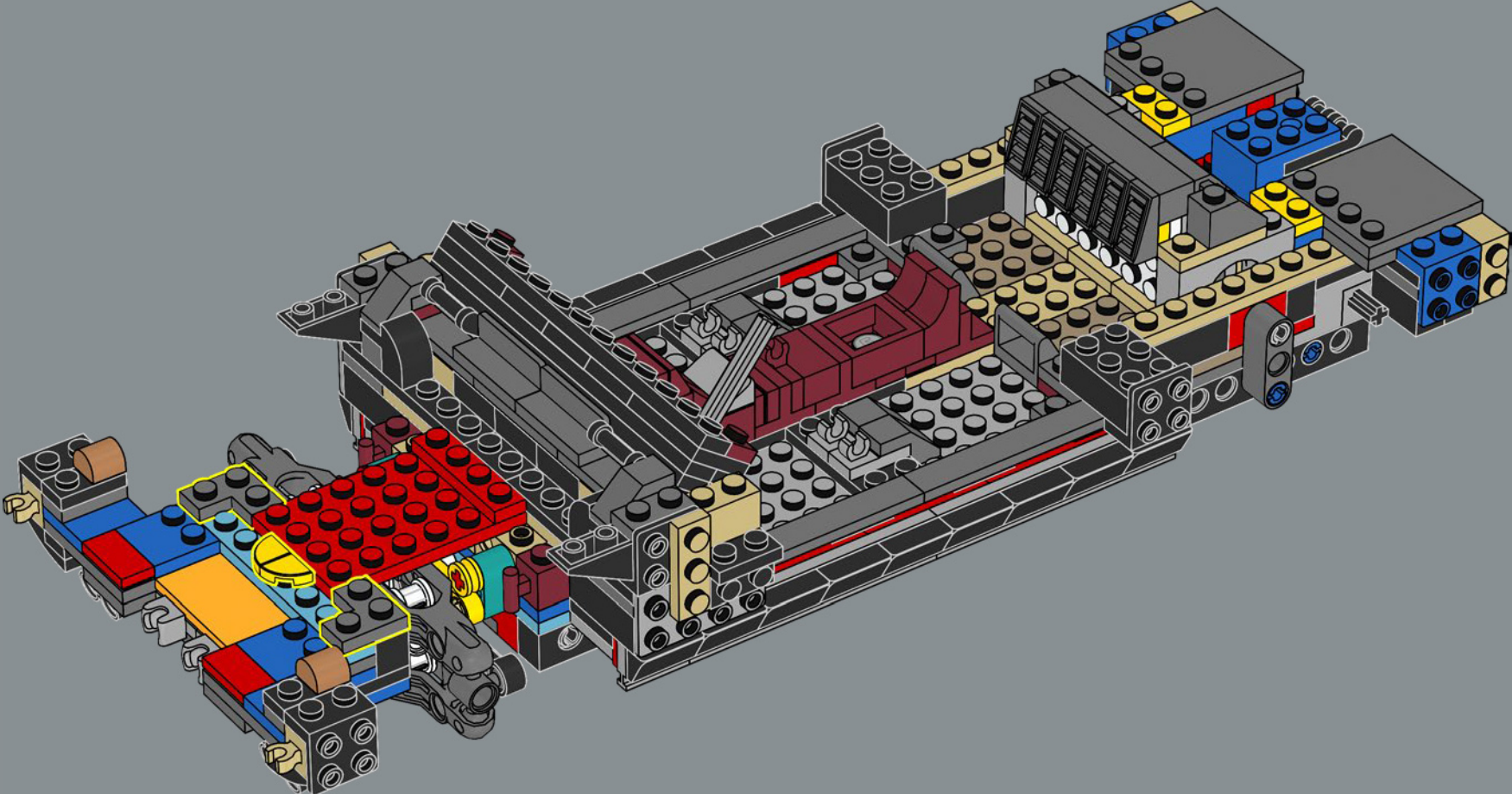

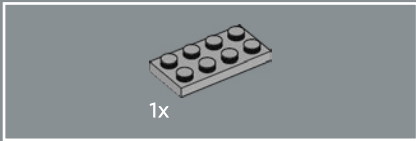
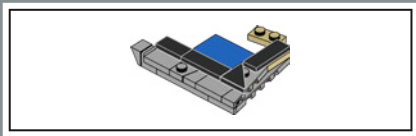

106

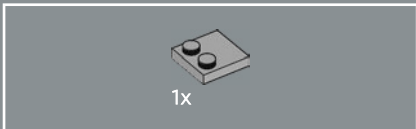
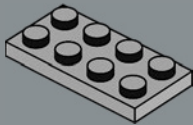

107

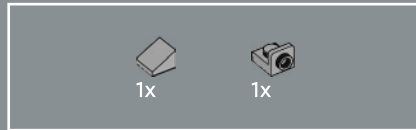
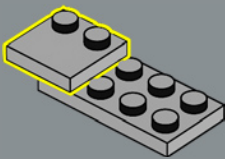

108

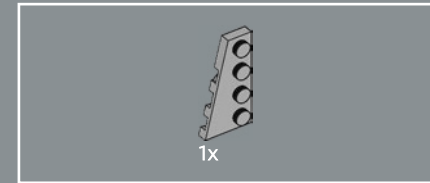
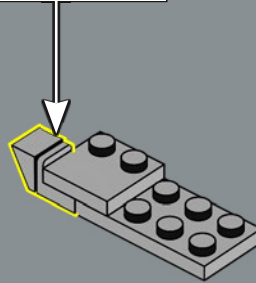
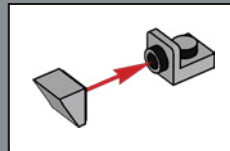

109

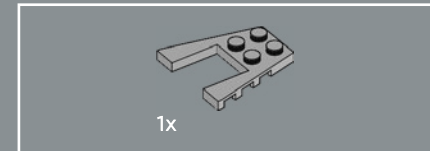
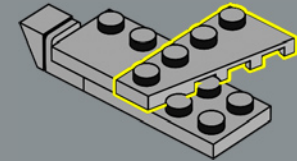

110

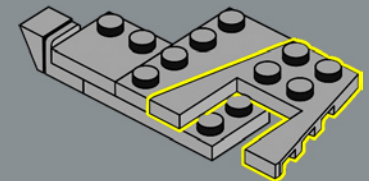

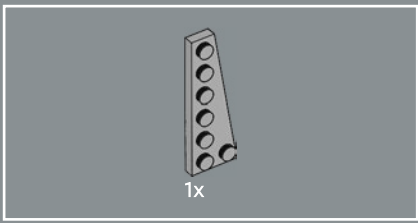

111

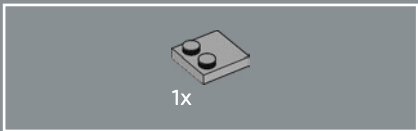
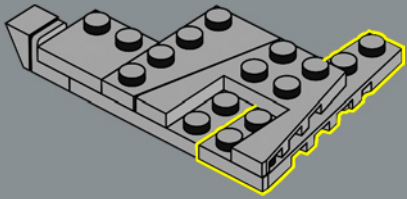

112

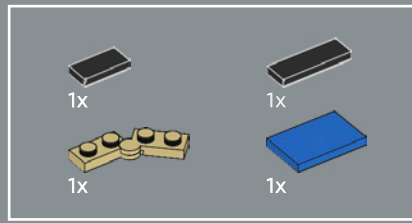
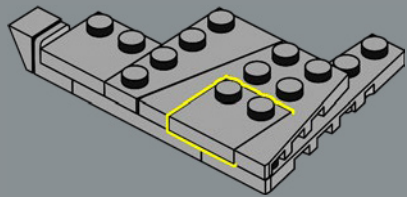

113

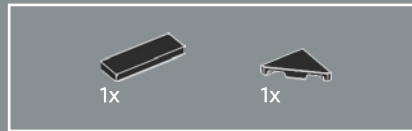
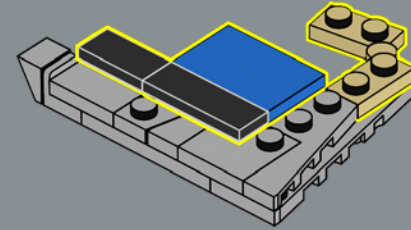

114

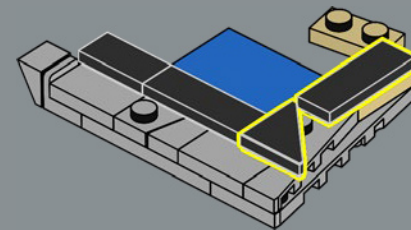

115

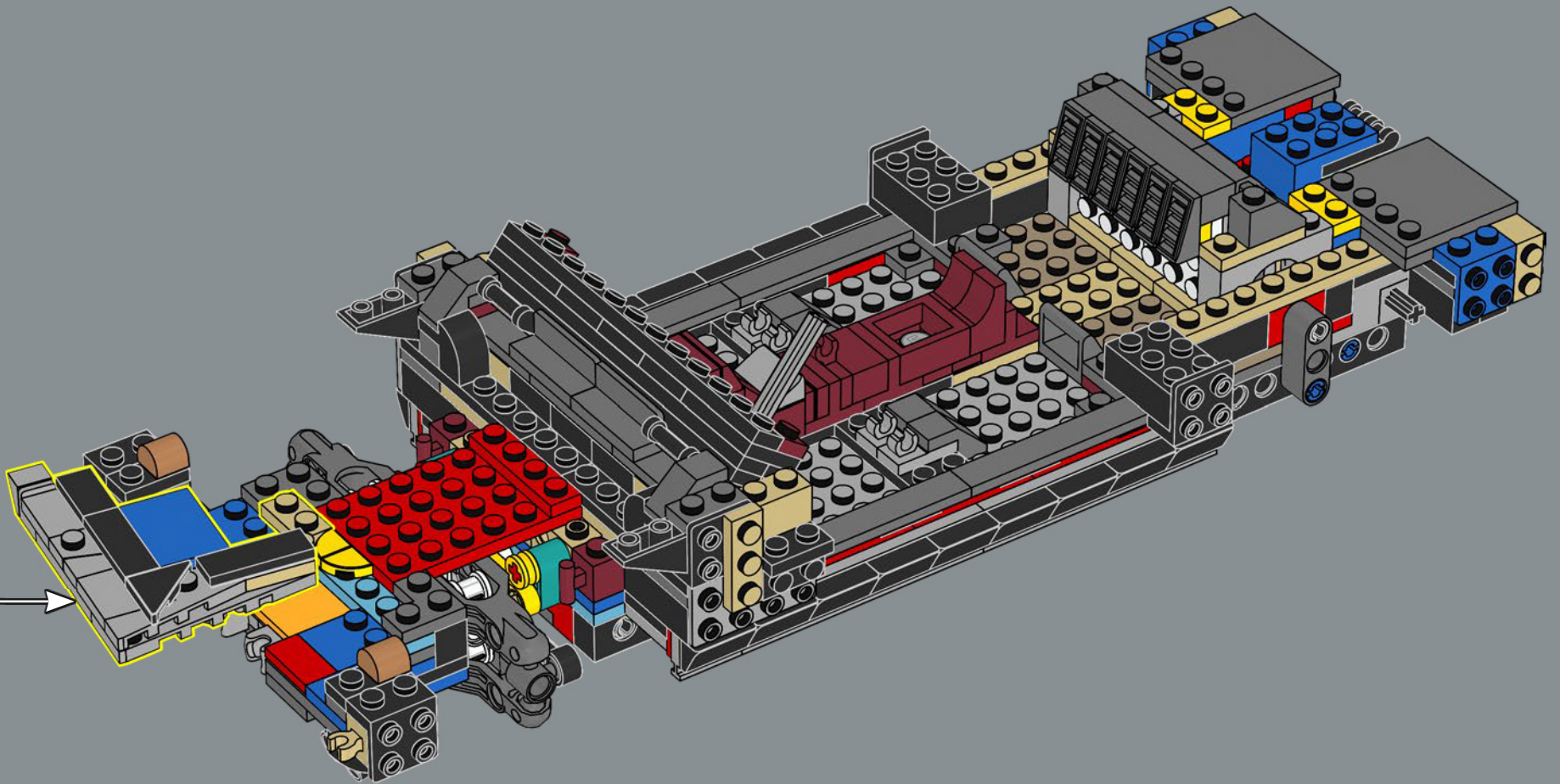

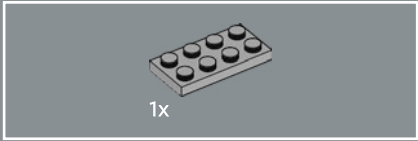
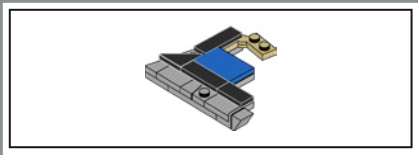

1x

116

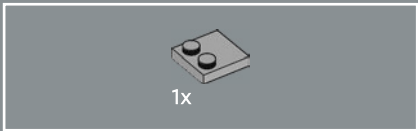
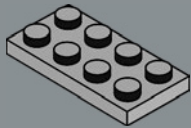

1x

117

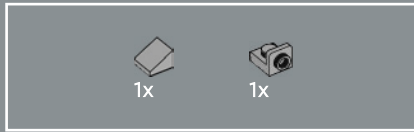
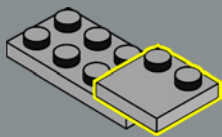

1x

1x

118

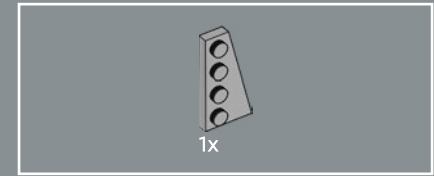
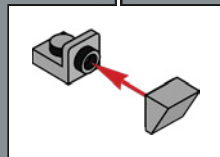
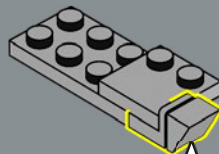

1x

119

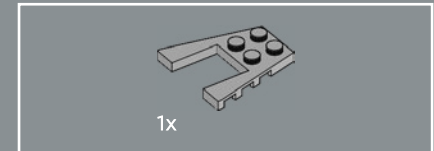
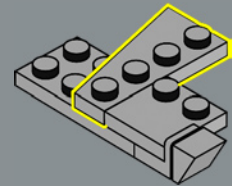

1x

120

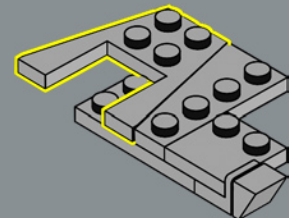

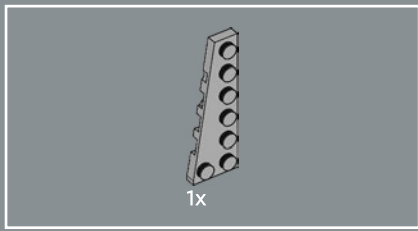

121

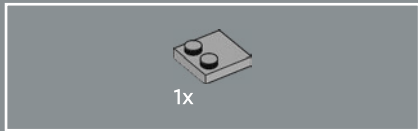
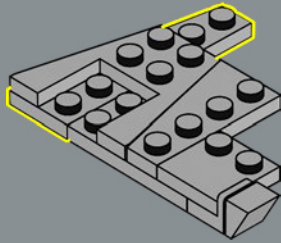

122

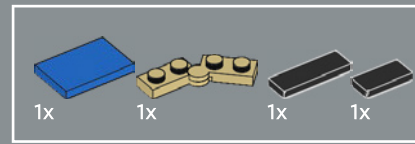
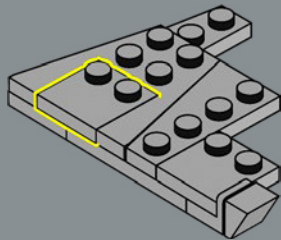

123

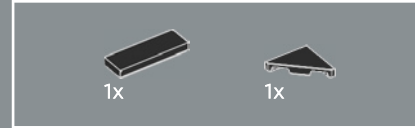
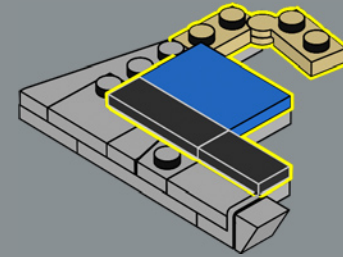

124

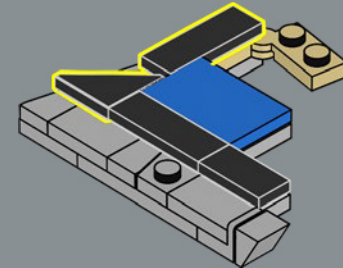

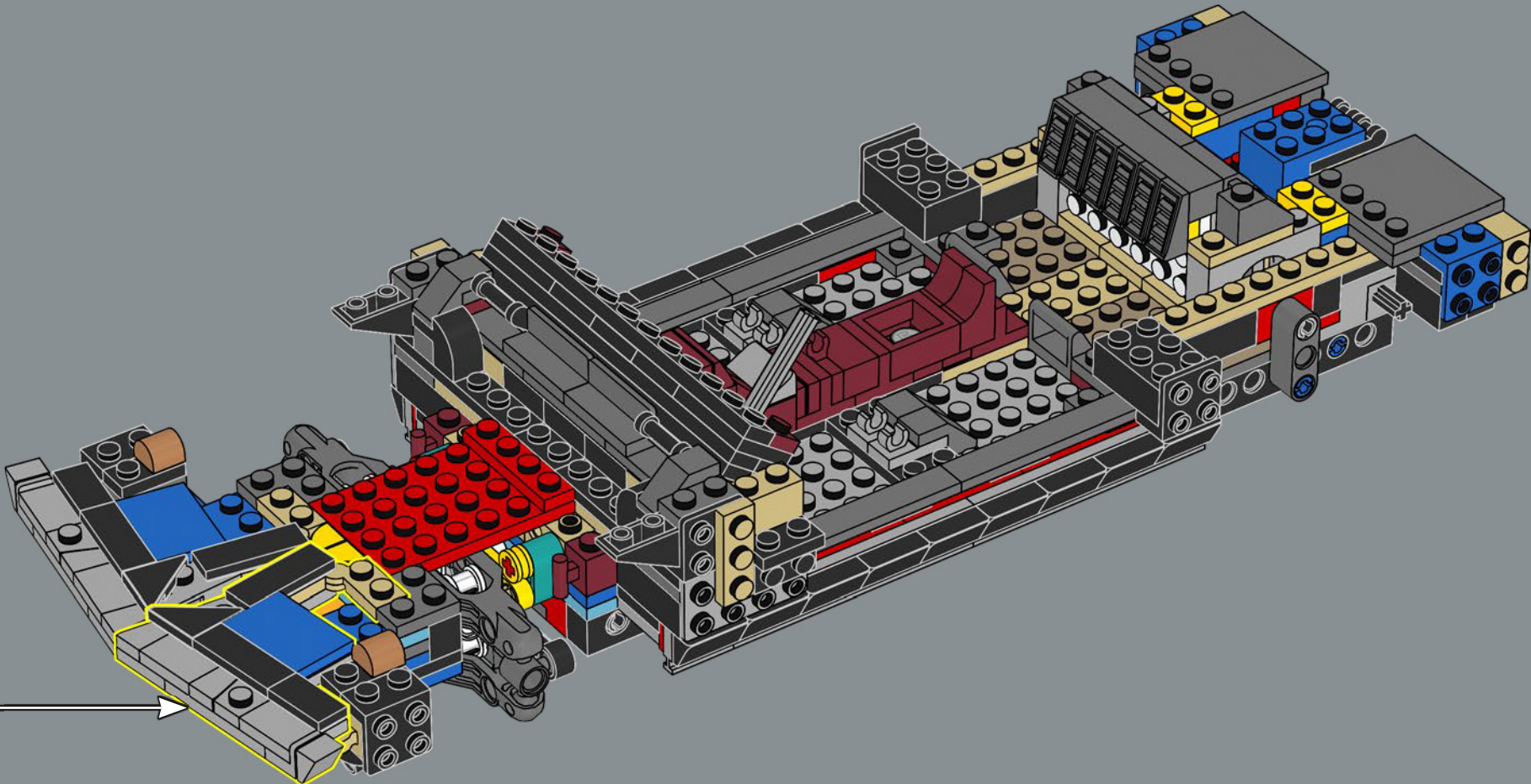

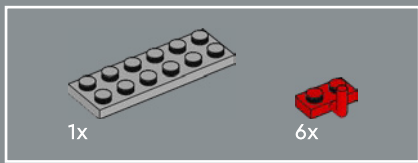

126

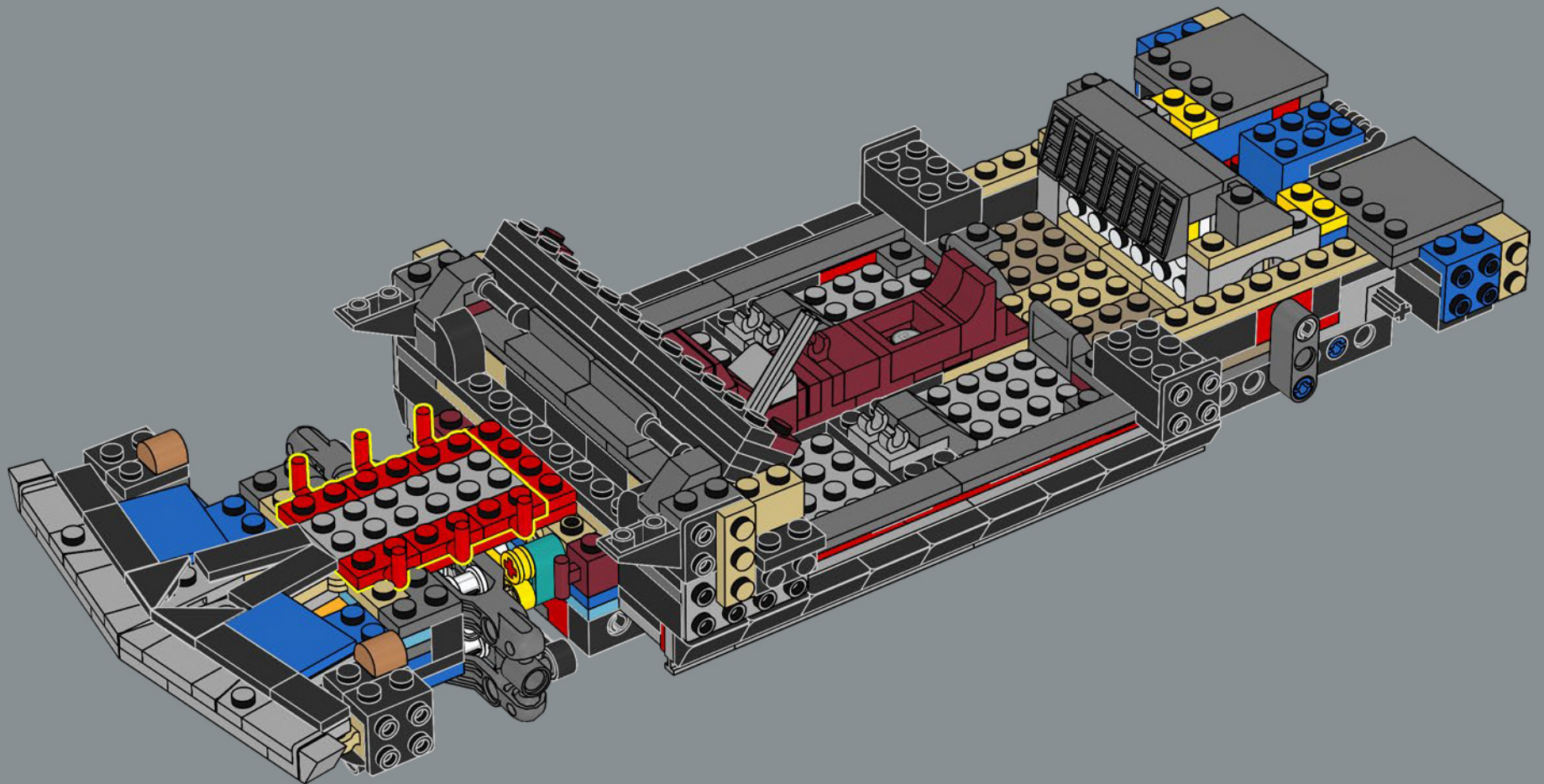

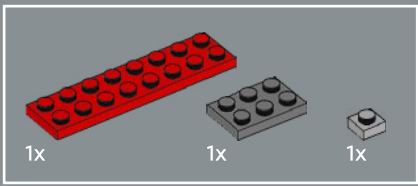

127

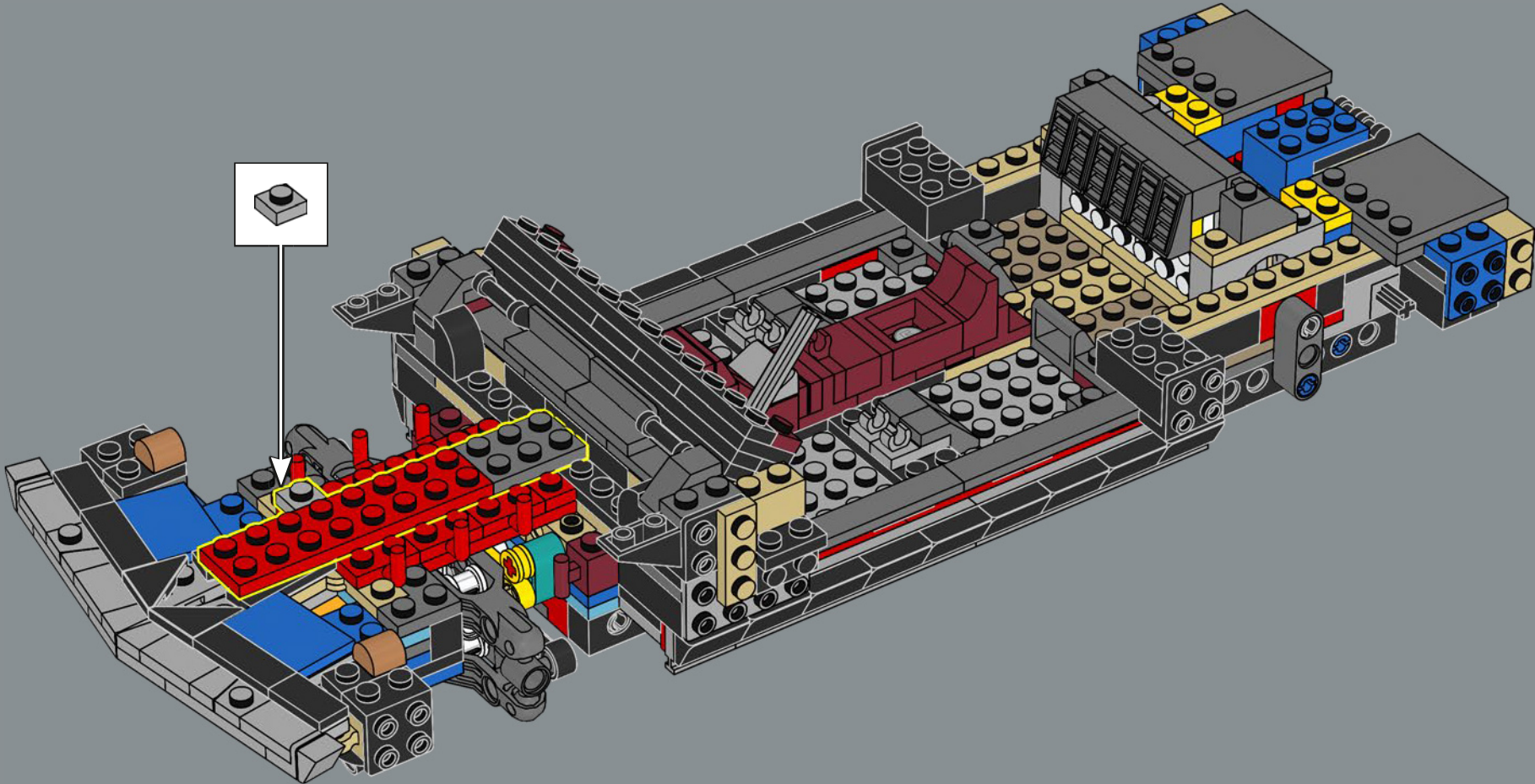

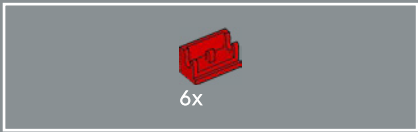

128

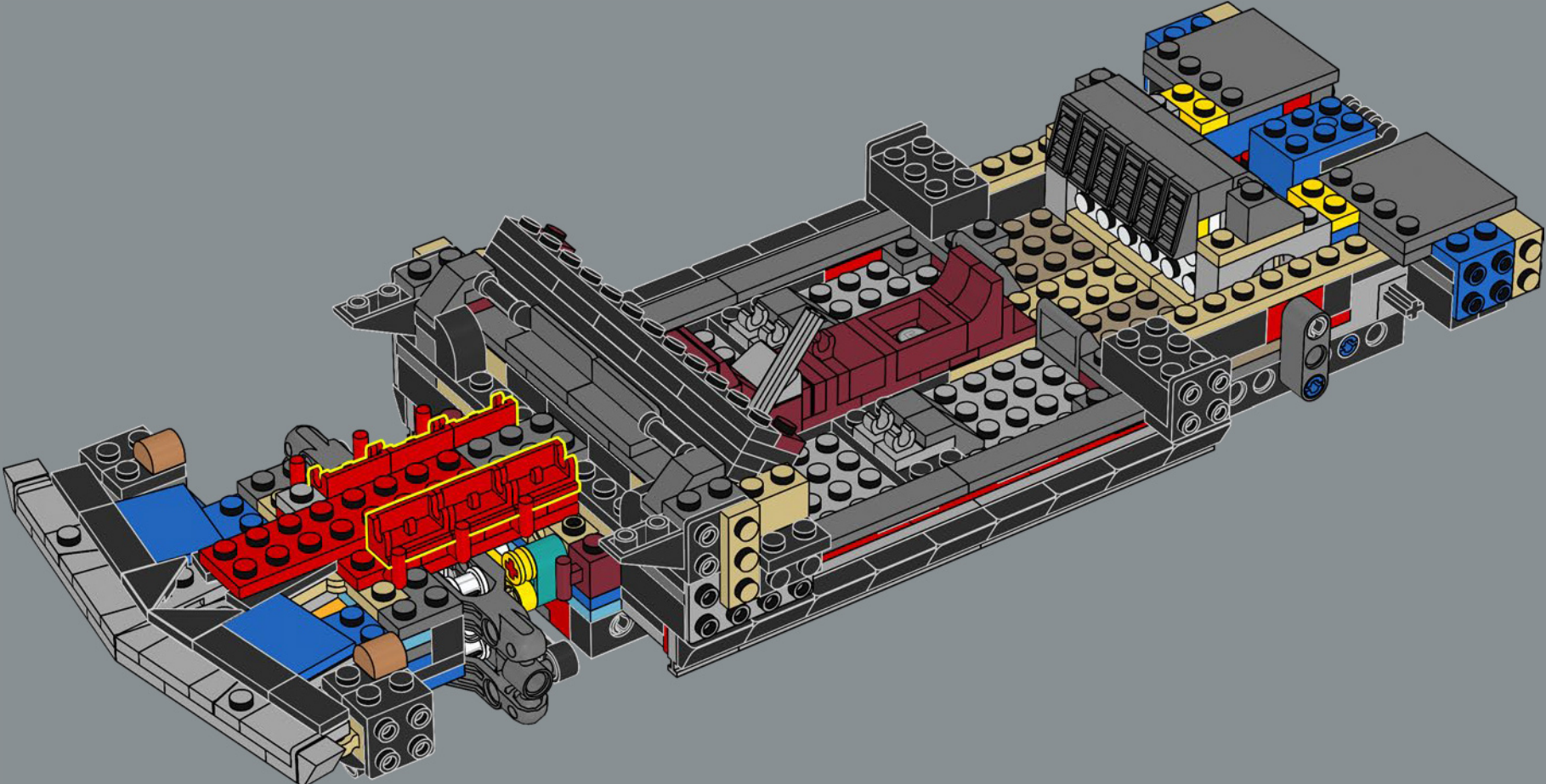

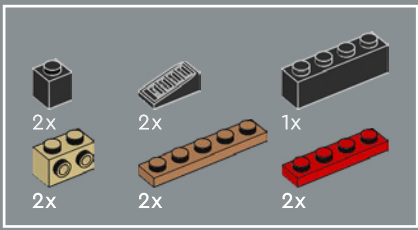

129

1

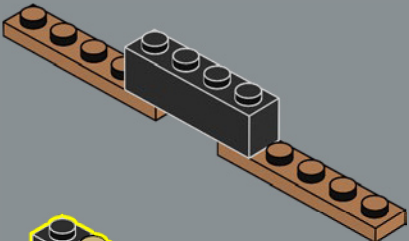

2

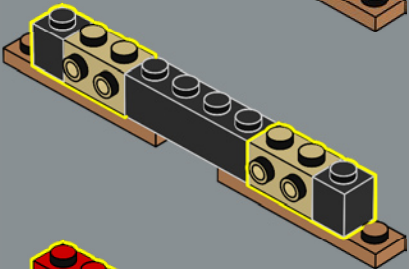

3

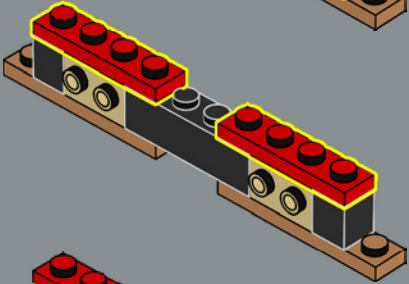

4

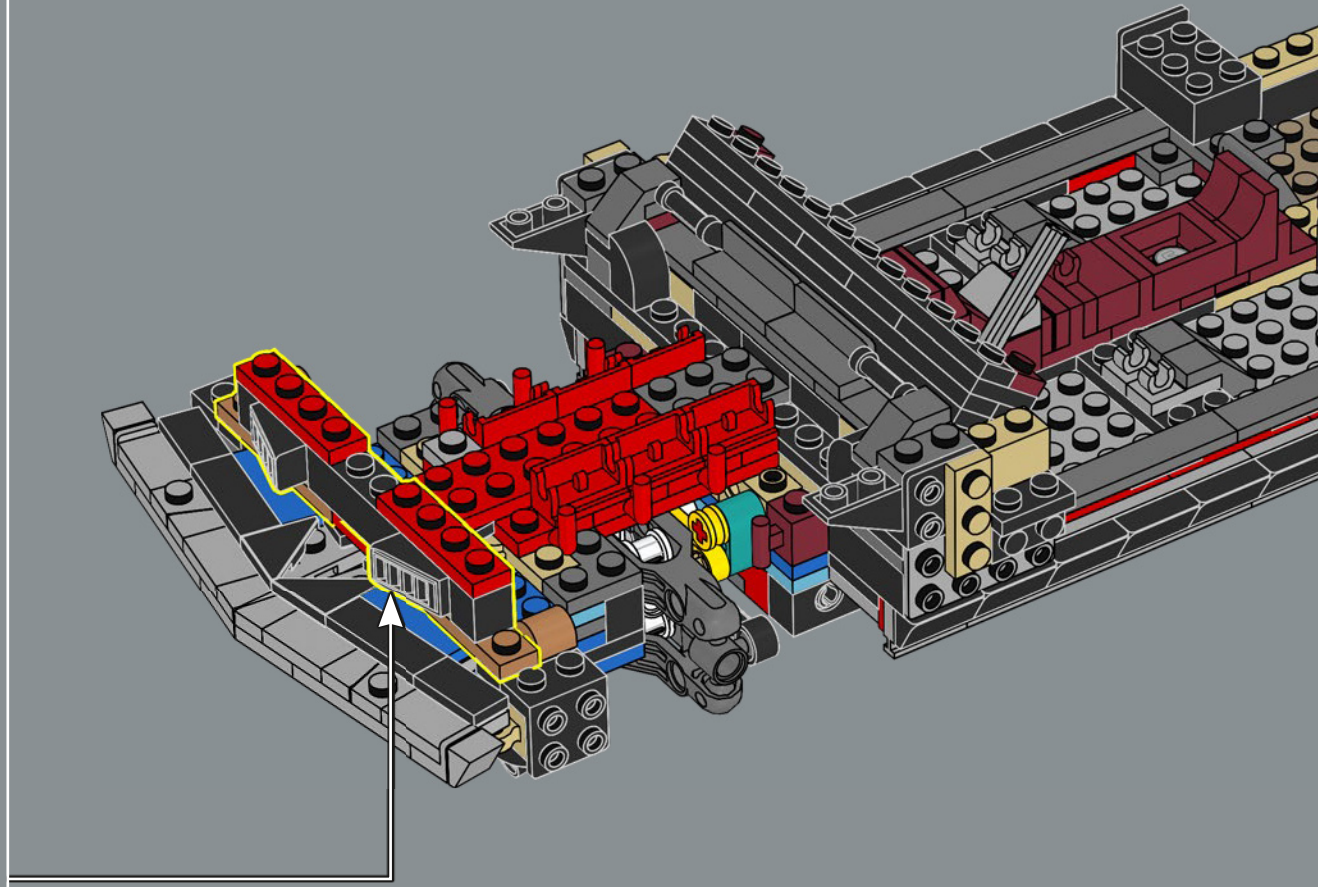
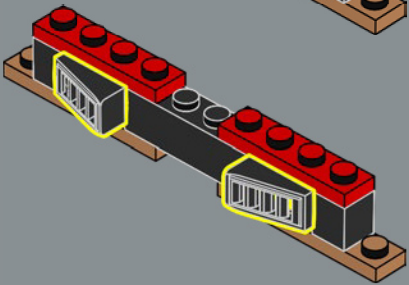

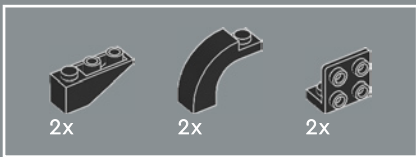

130

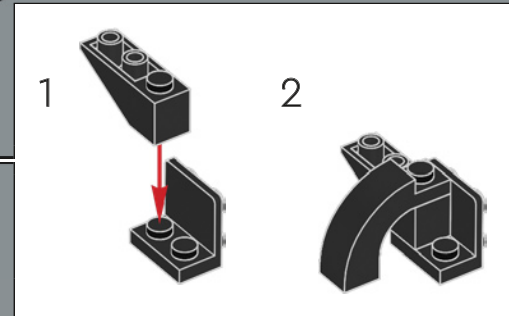
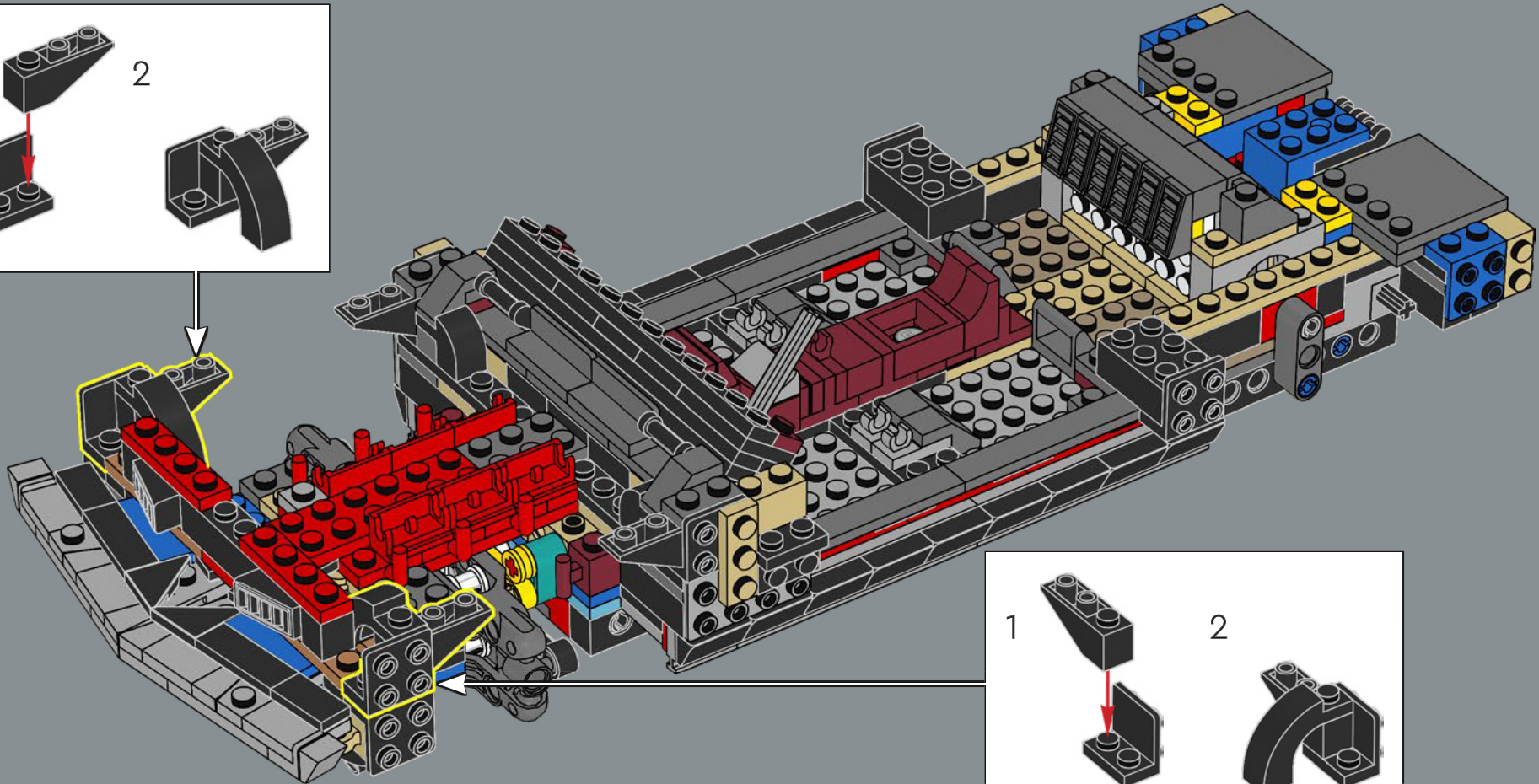
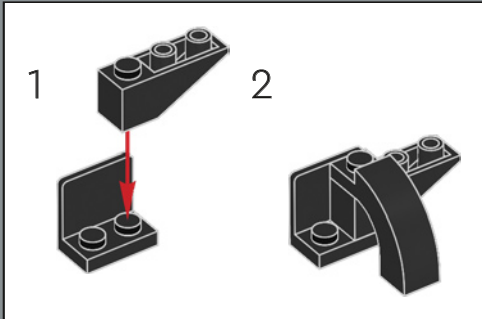

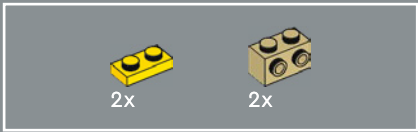

131

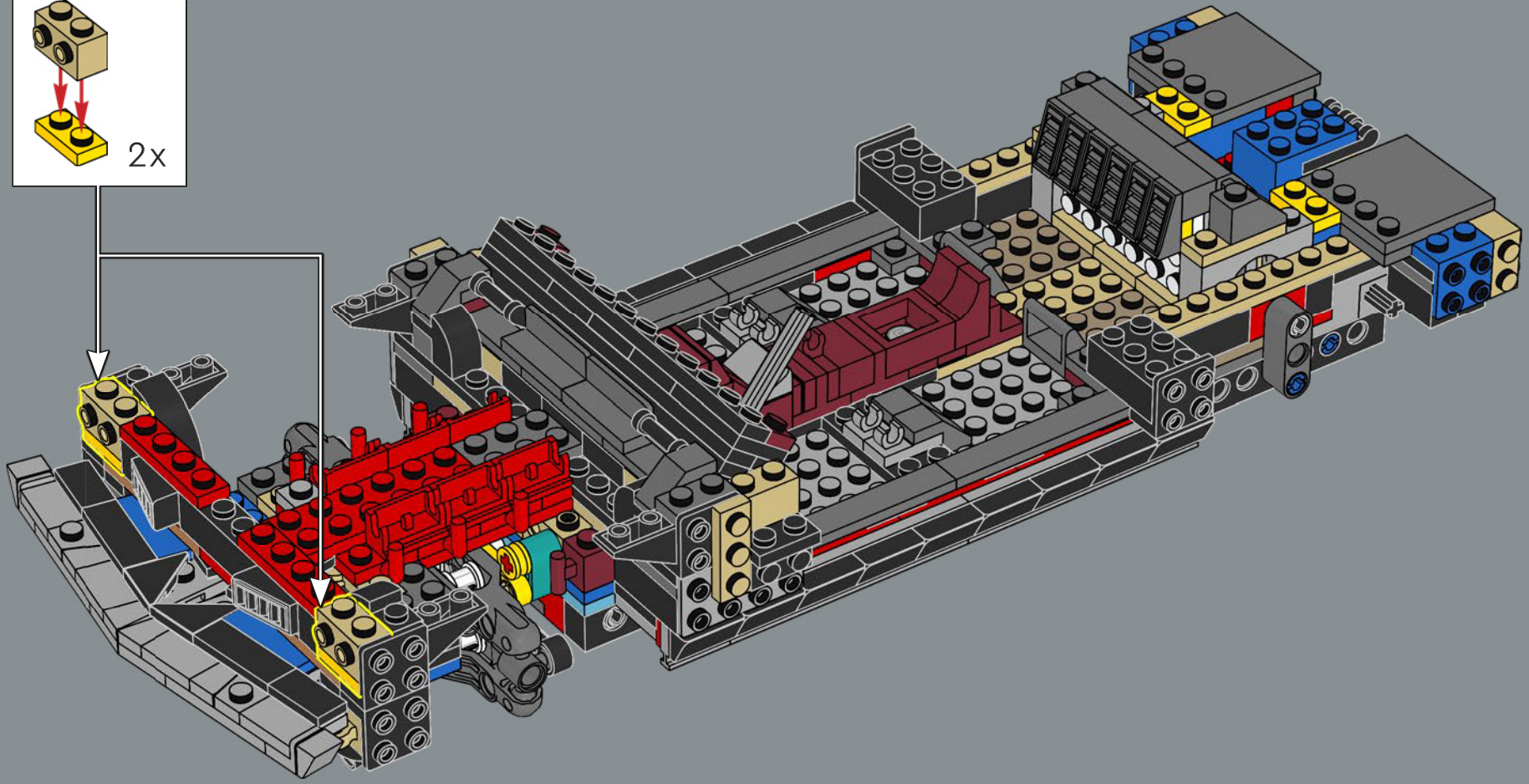
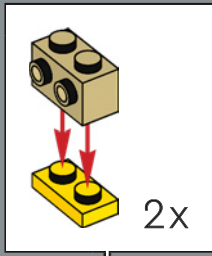

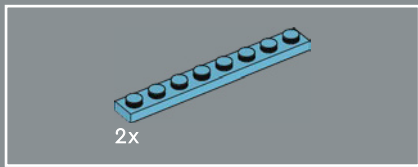

132

La presentazione della Chevrolet Camaro alla stampa nel 1966 fu la prima teleconferenza su scala mondiale, con oltre 200 giornalisti provenienti da 14 città degli Stati Uniti che parteciparono all'evento.

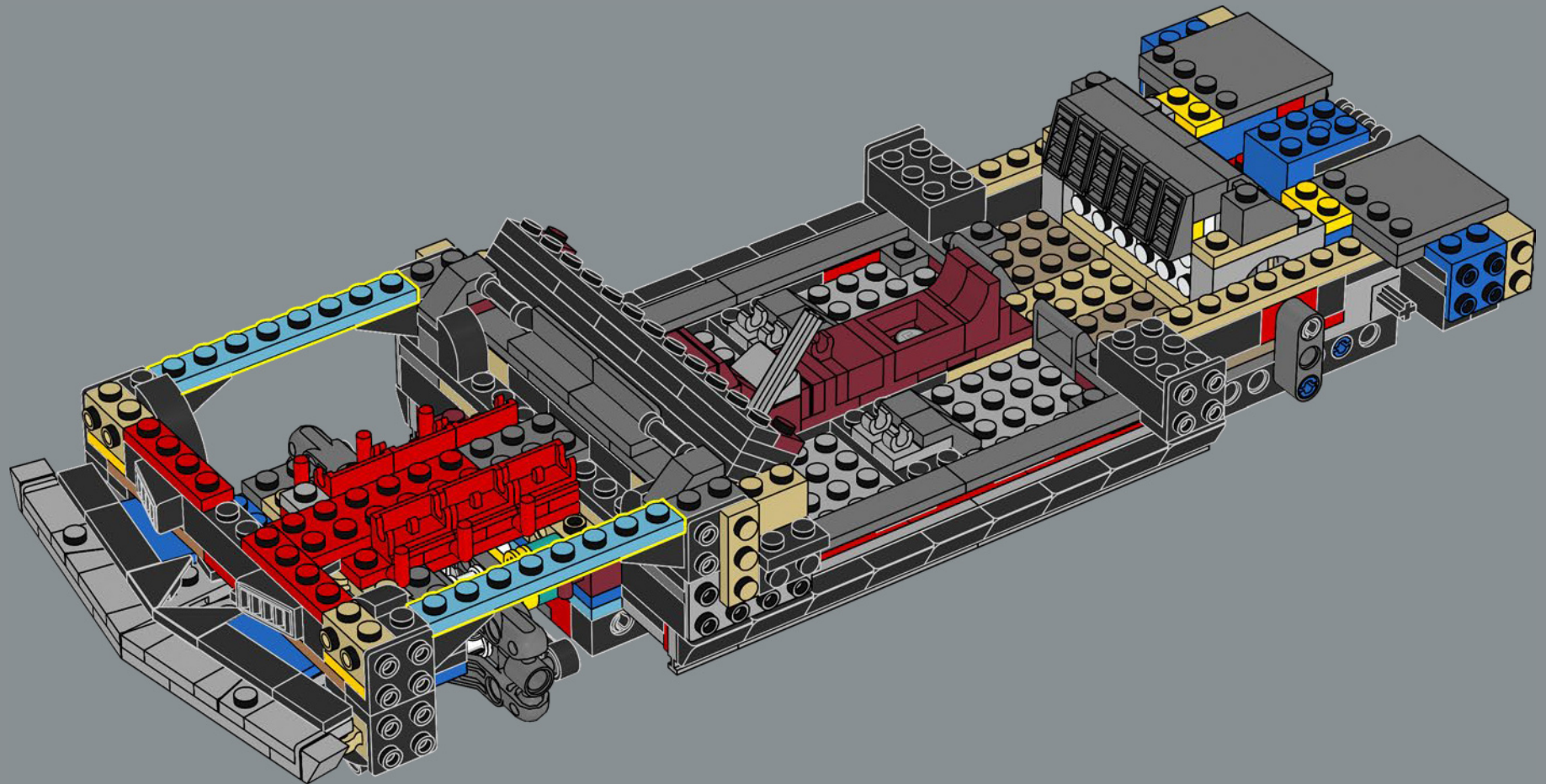



133

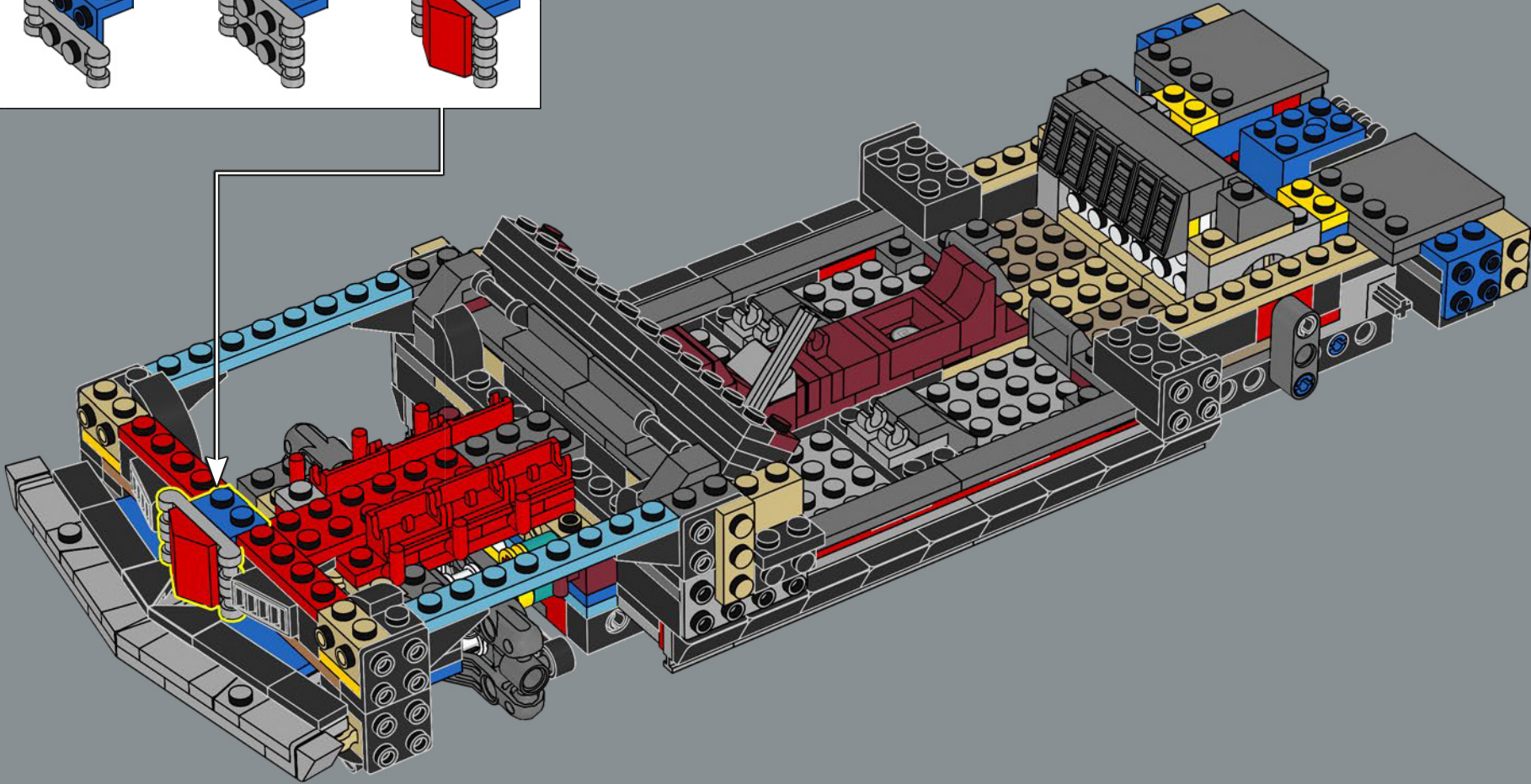
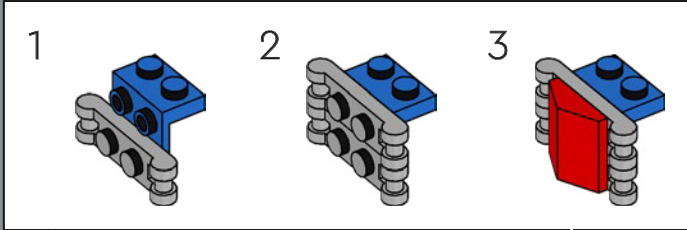



134

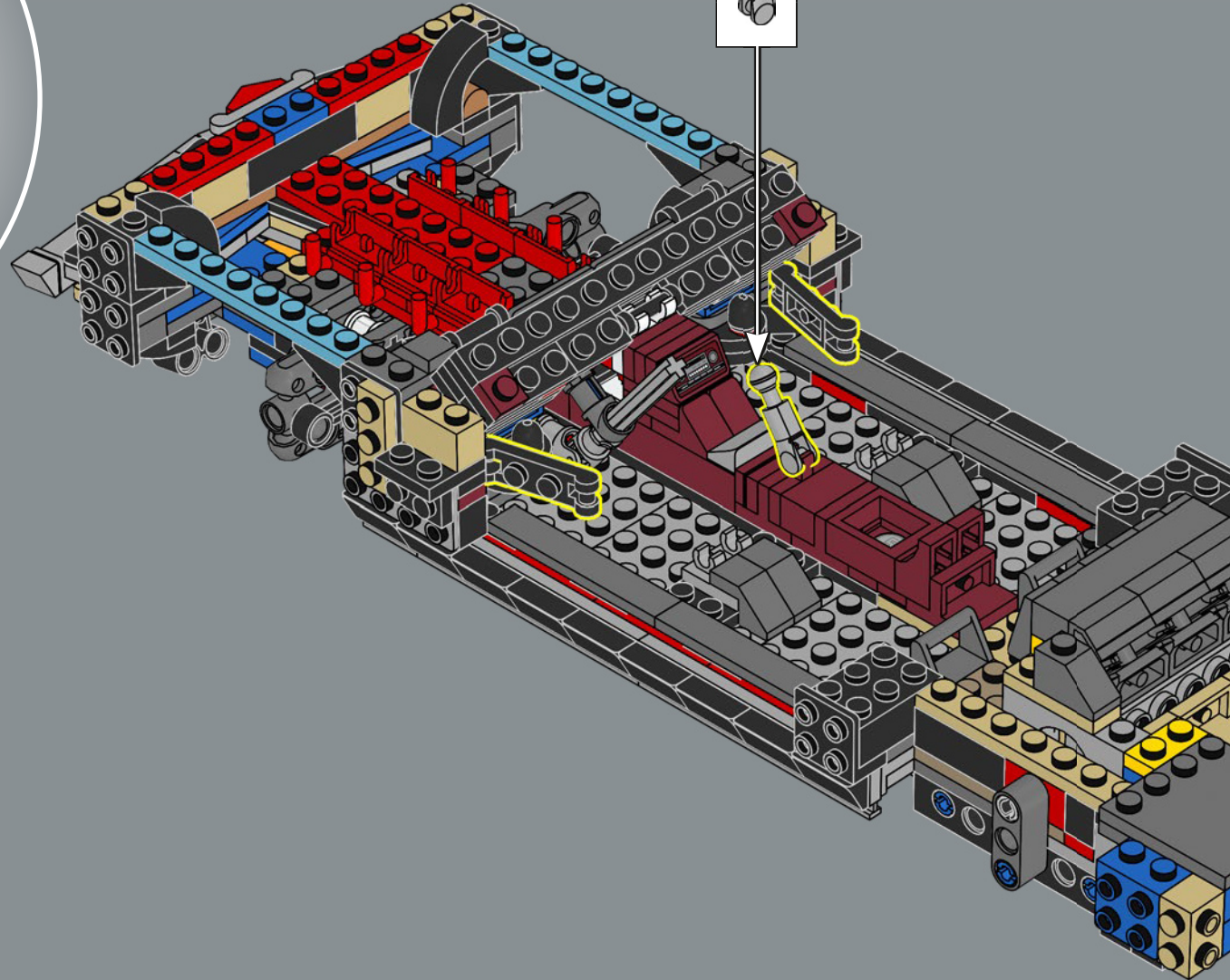
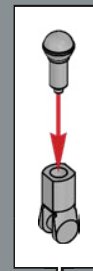

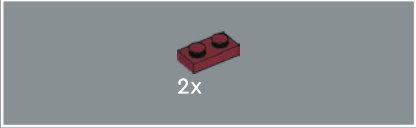
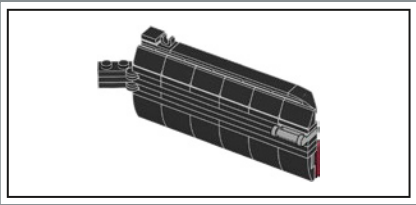

2x

135

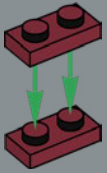

1x

136

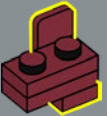

1x

137

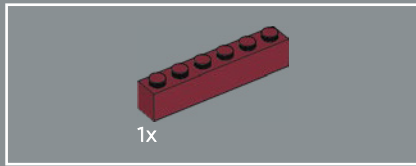
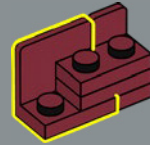

1x

138

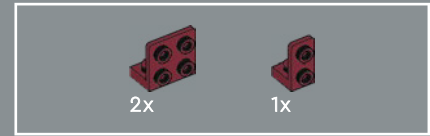
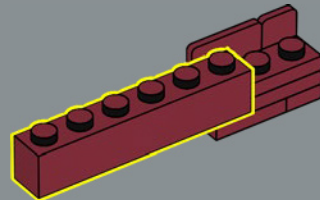

2x

1x

139

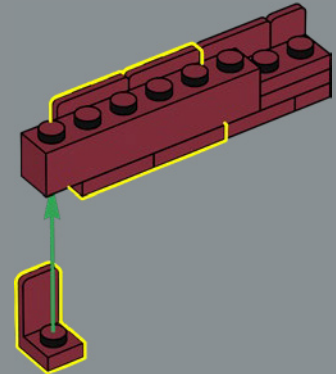



140

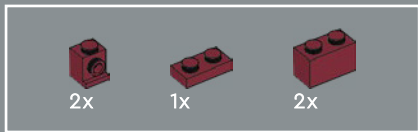
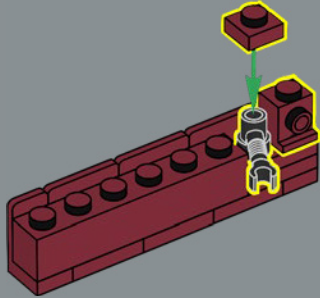

141

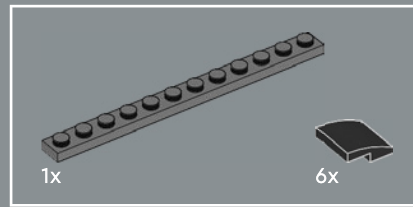
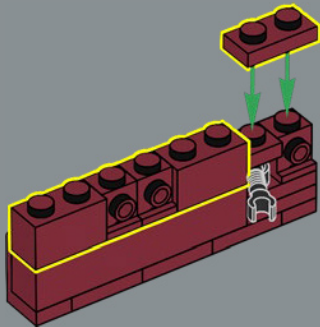

142

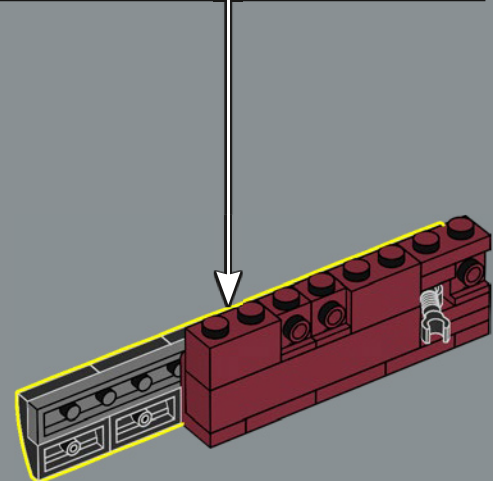
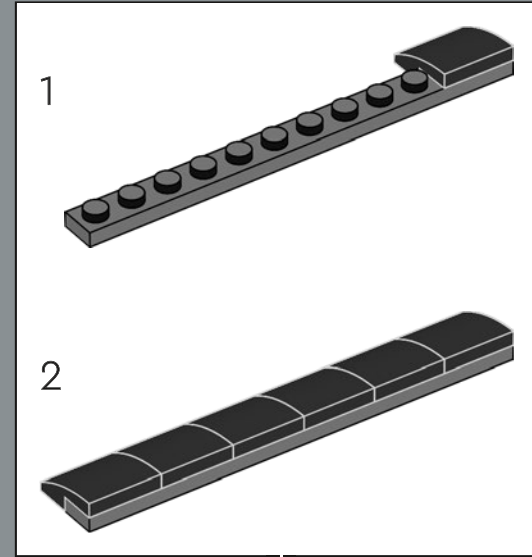

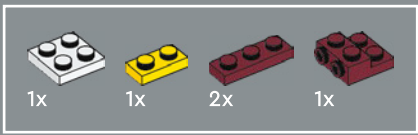

143

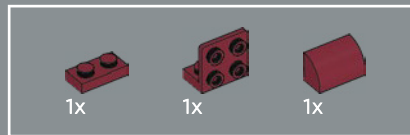
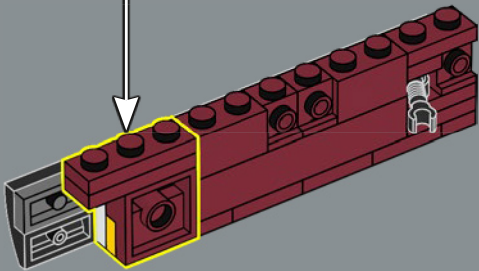
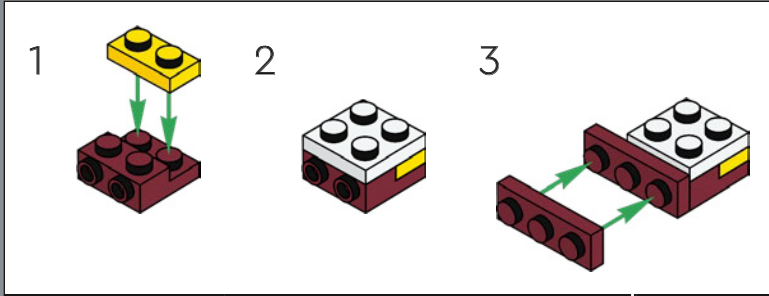

144

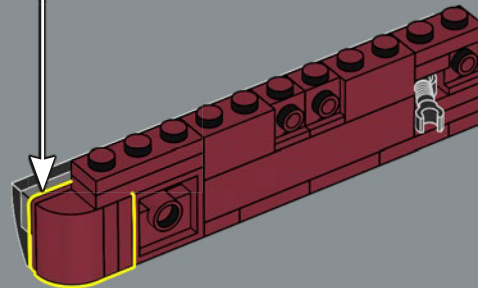
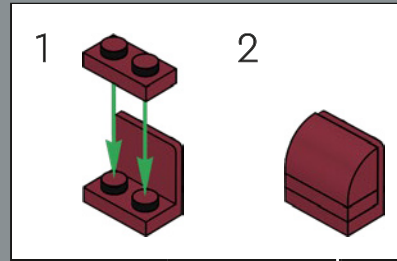

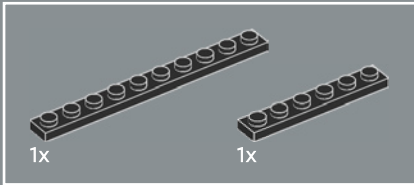
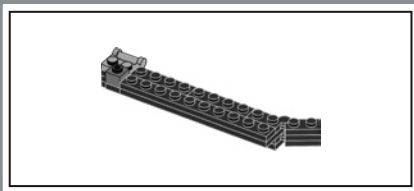

145

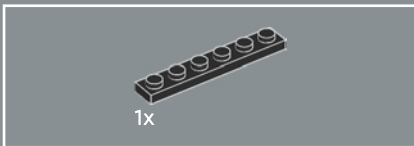
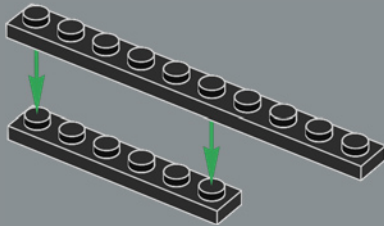

146

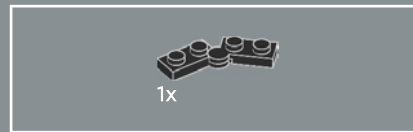
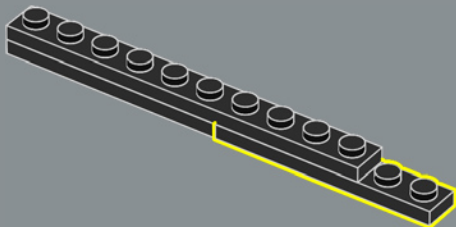

147

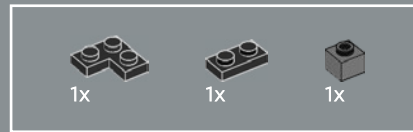
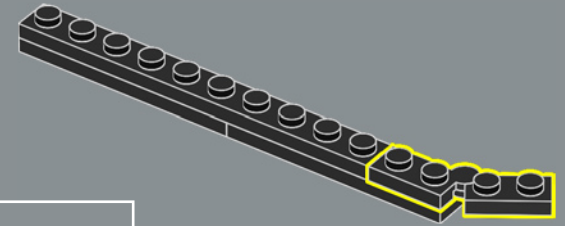

148

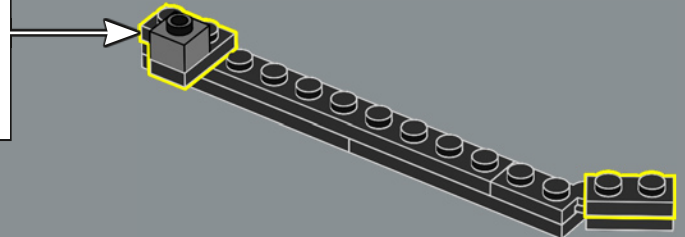
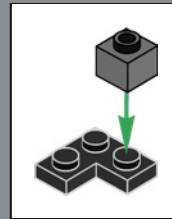

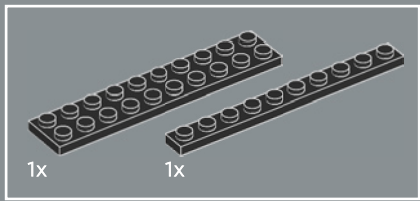

149

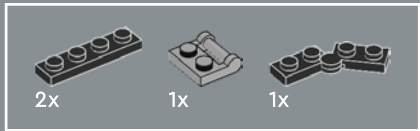
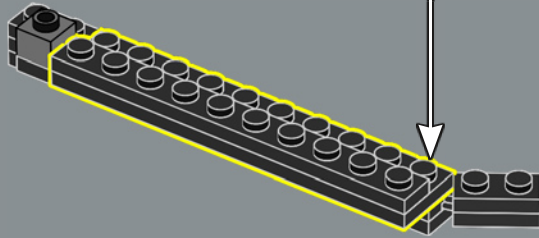
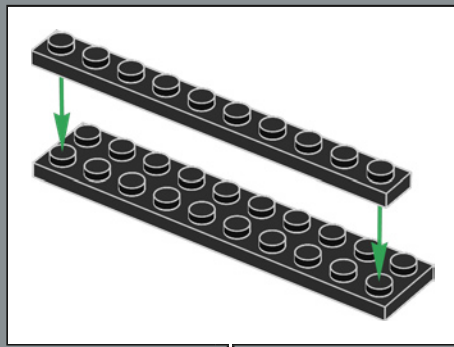

150

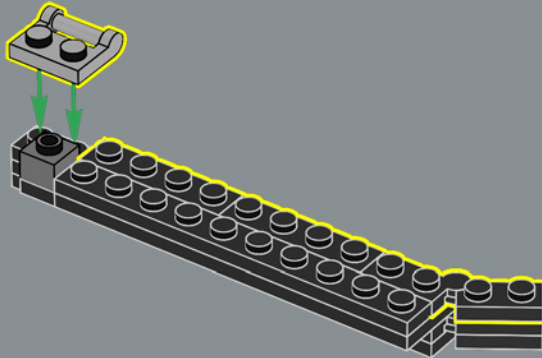

151

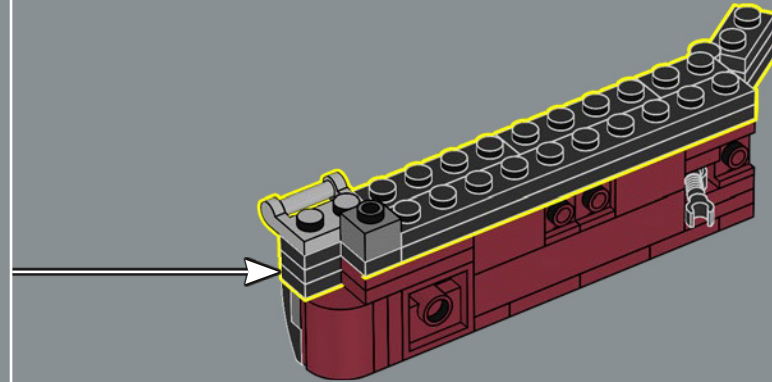

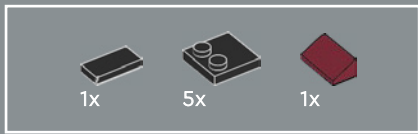

152

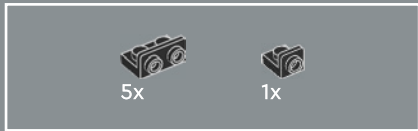
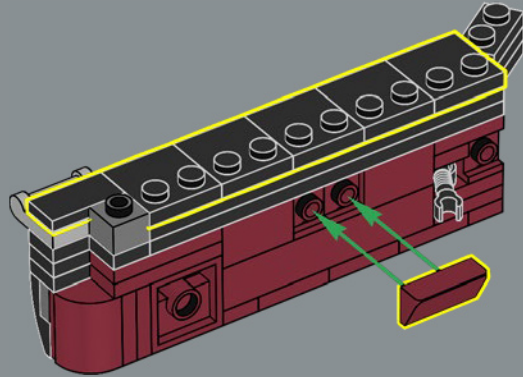

153

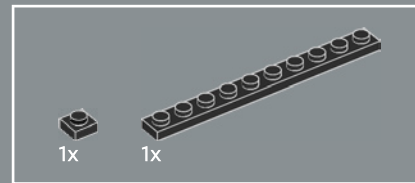
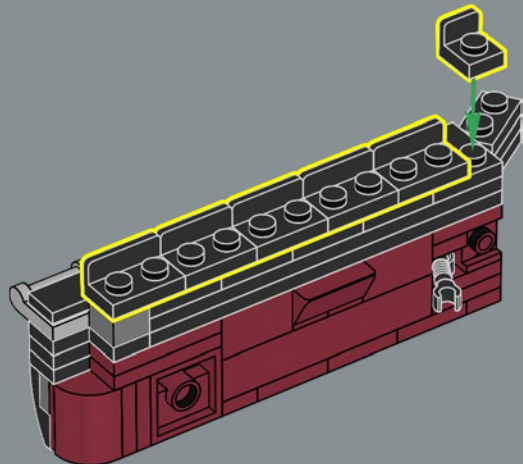

154

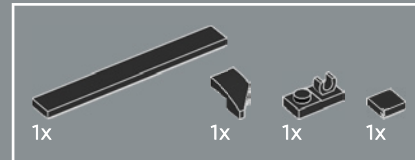
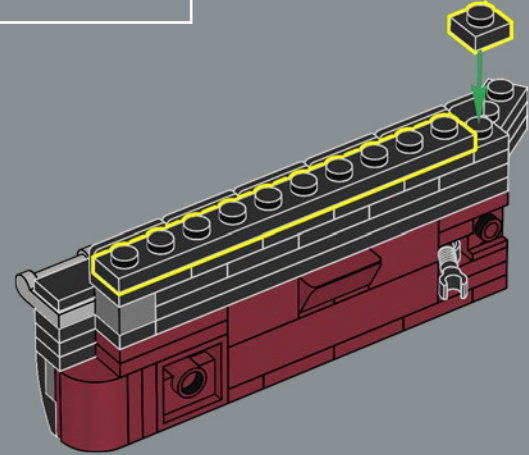

155

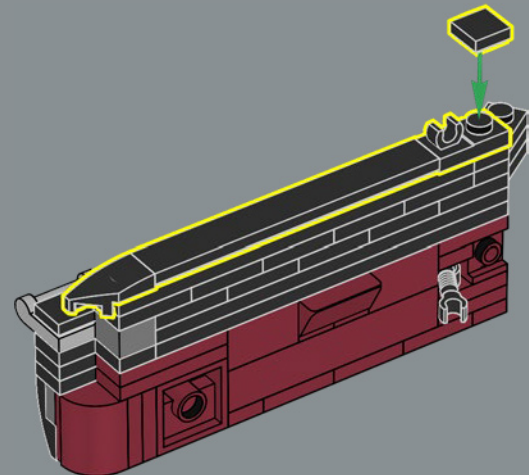



6x

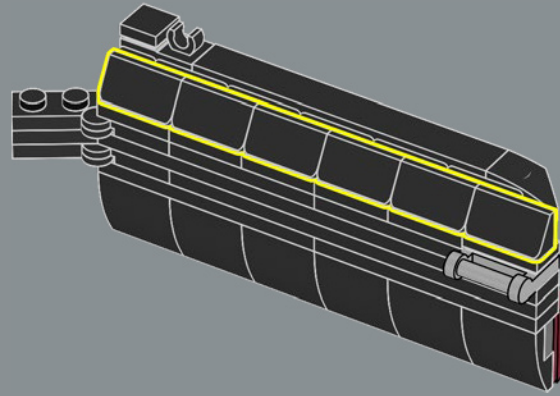

156

157

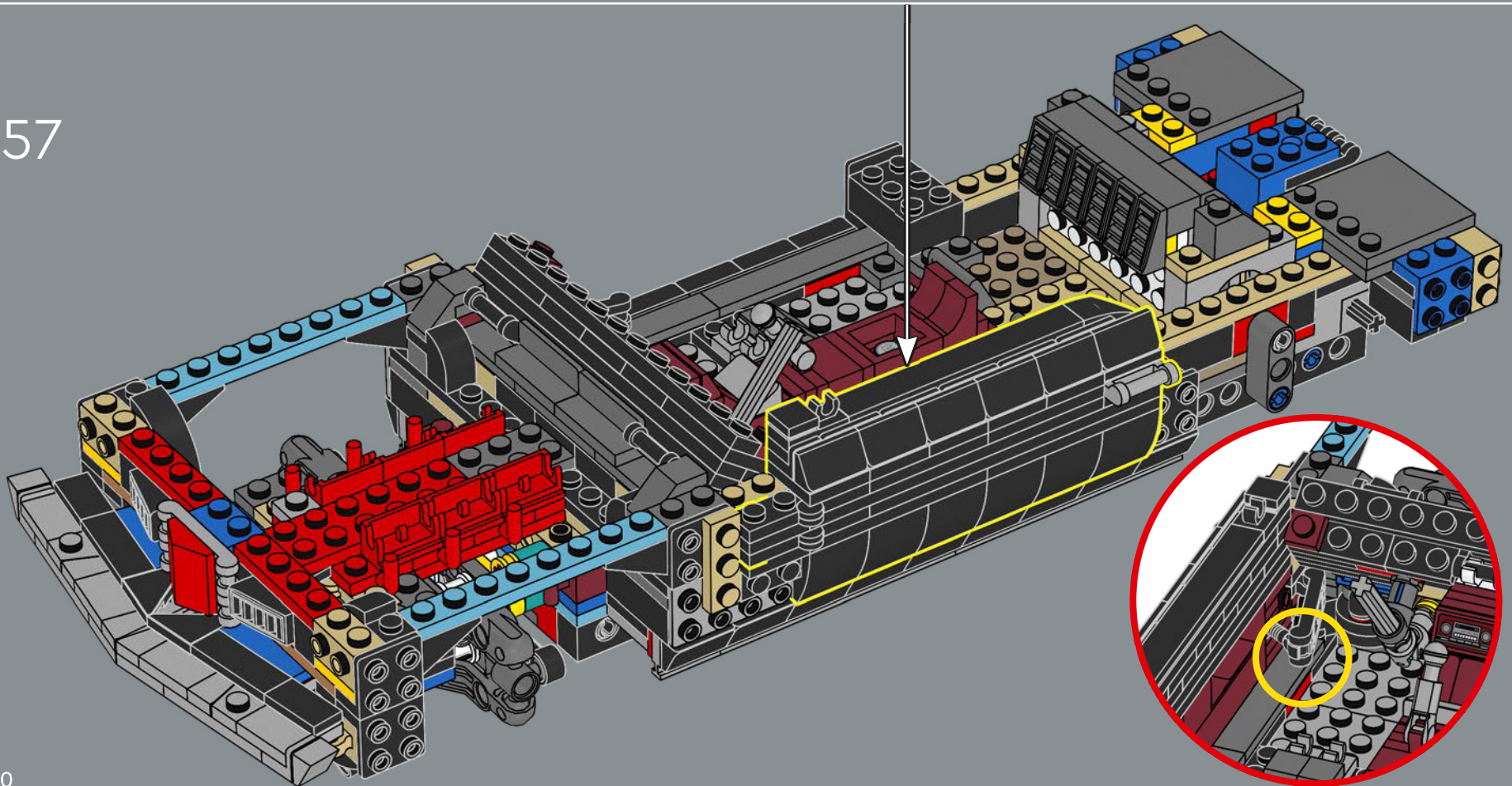



158

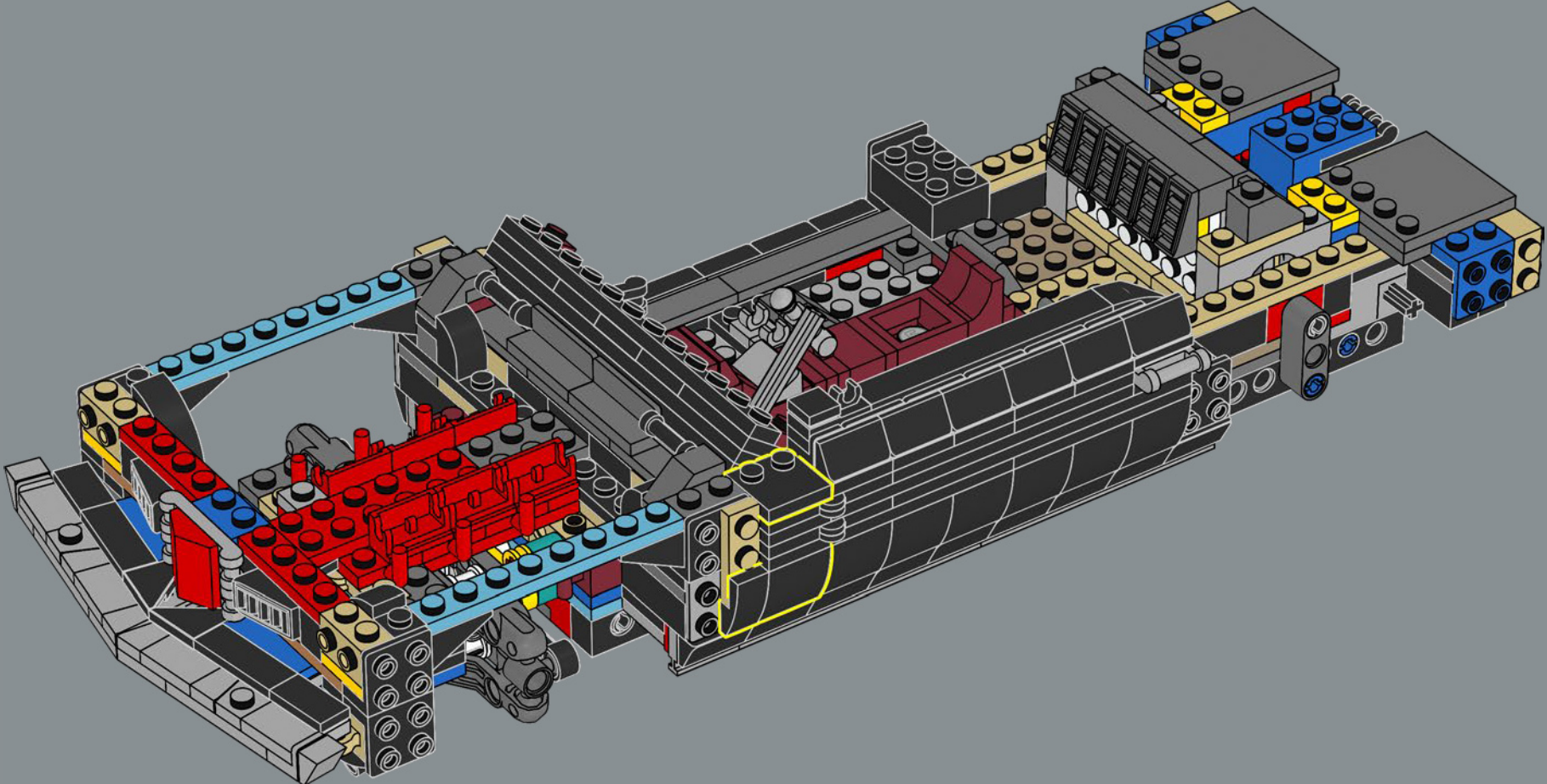

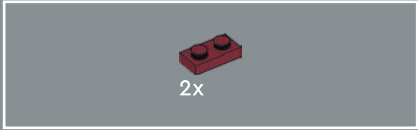
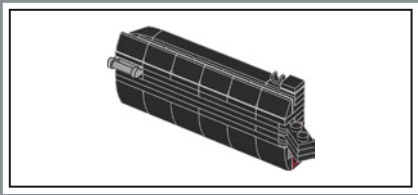

159

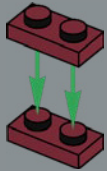

160

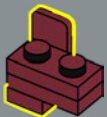

161

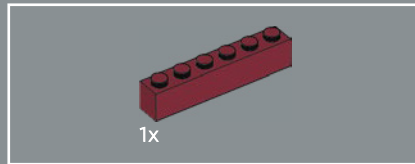
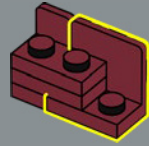

162

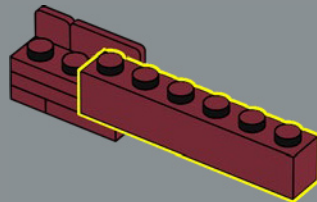

163

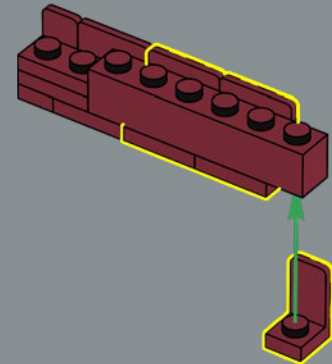



164

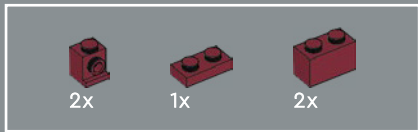
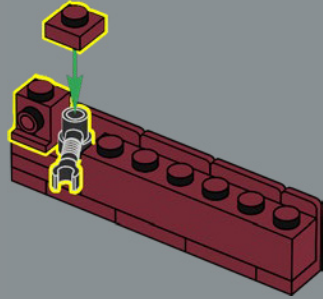

165

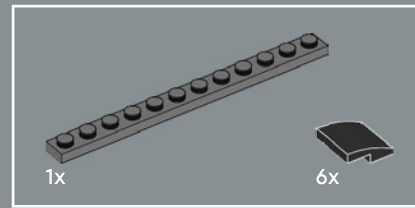
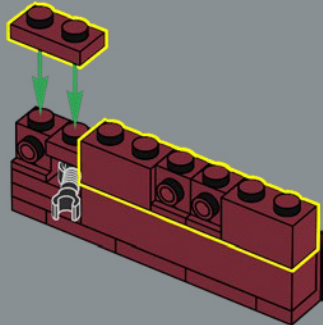

166

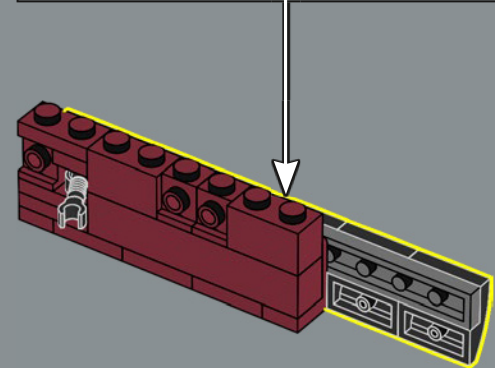
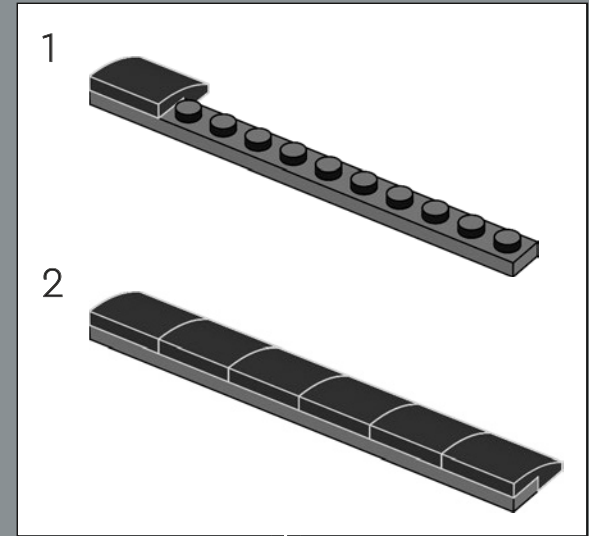

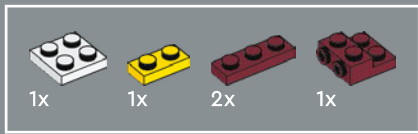

167

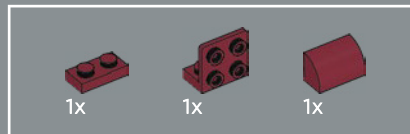
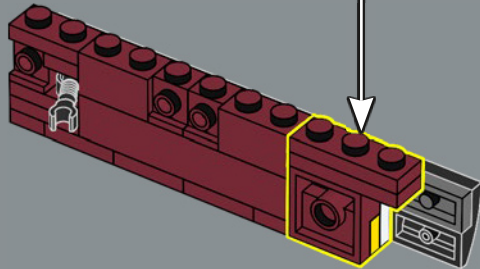
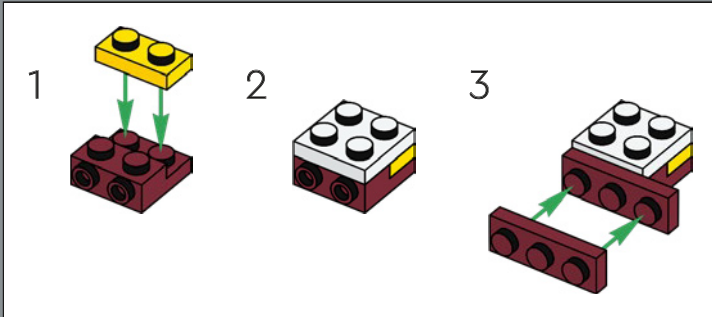

168

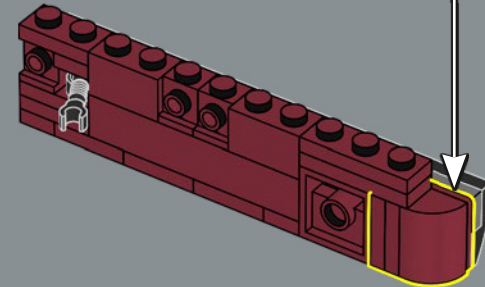
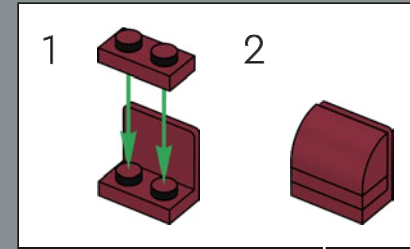

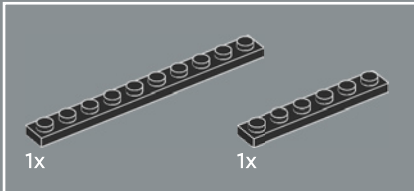
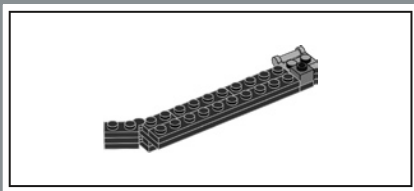

169

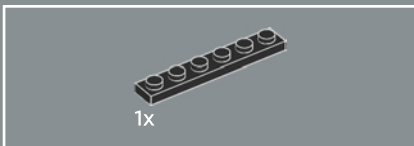
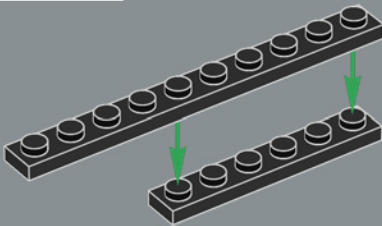

170

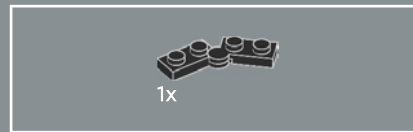
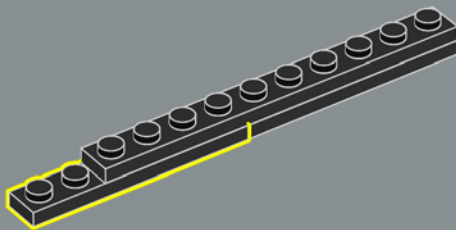

171

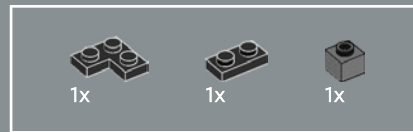
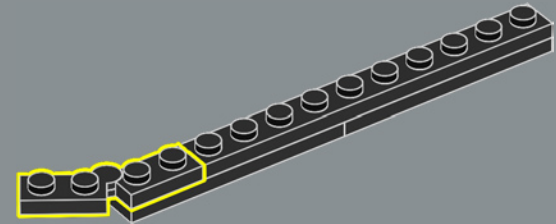

172

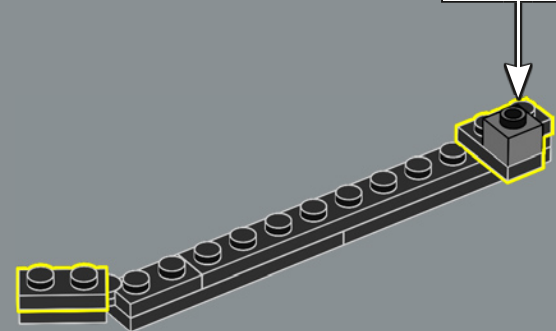
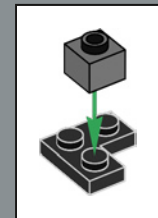

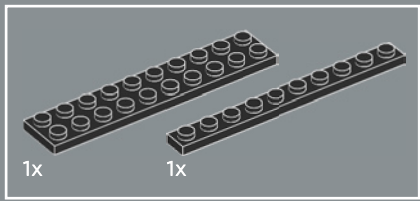

173

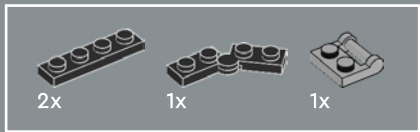
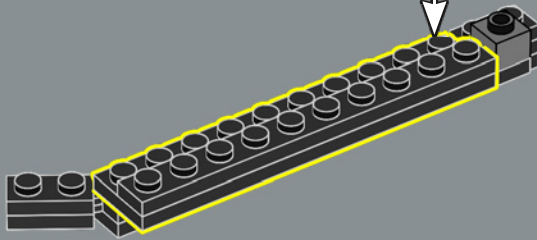
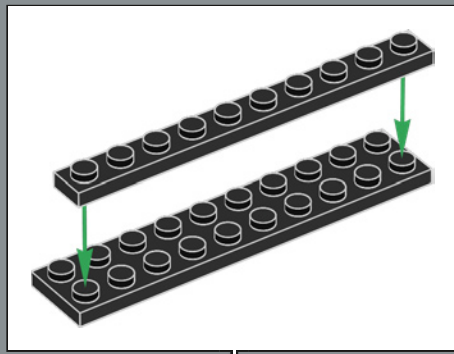

174

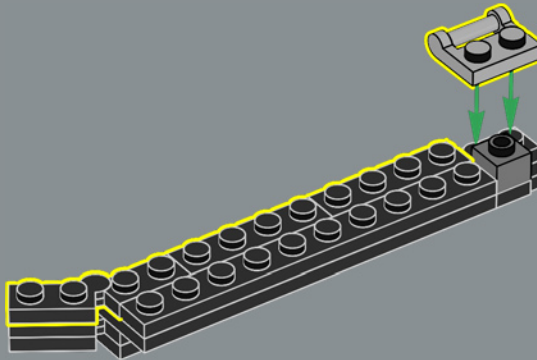

175

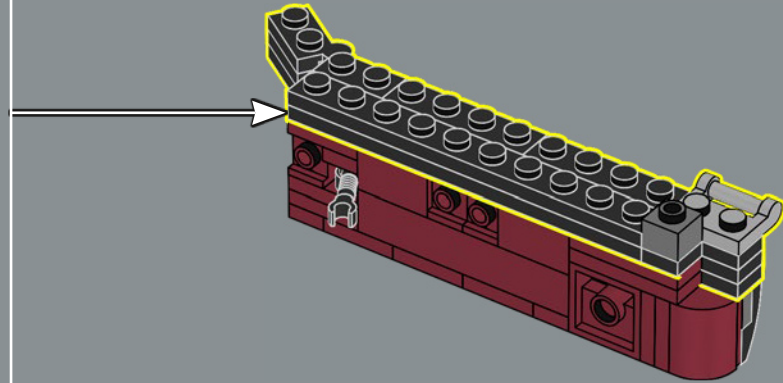

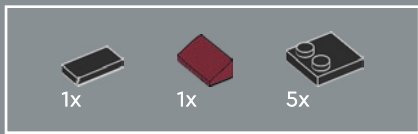

176

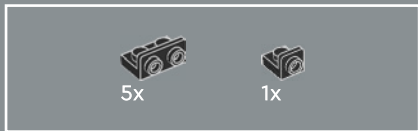
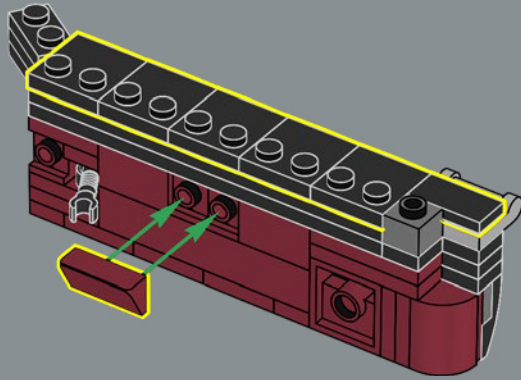

177

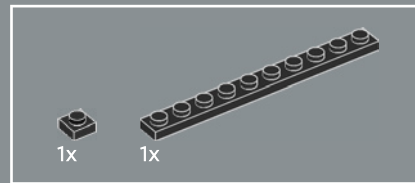
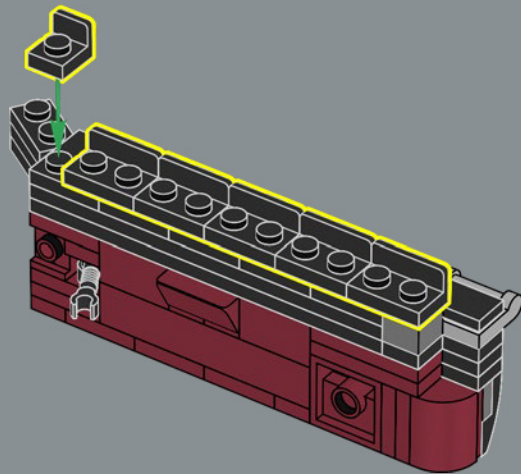

178

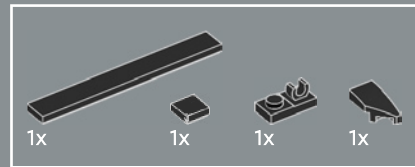
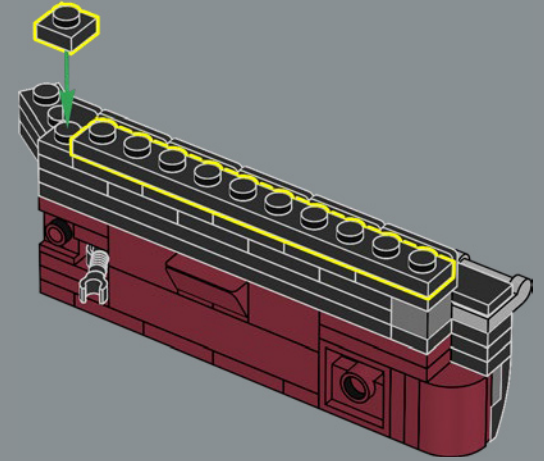

179

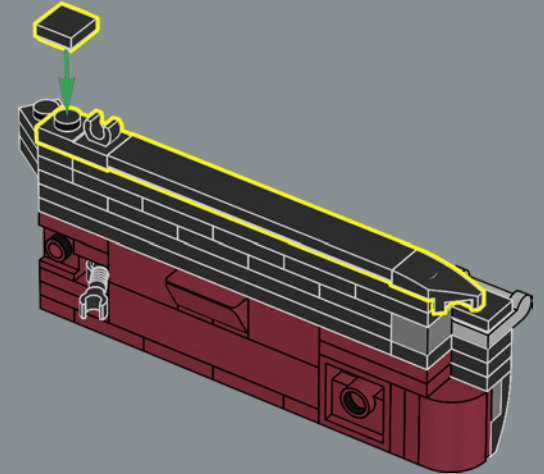



6x

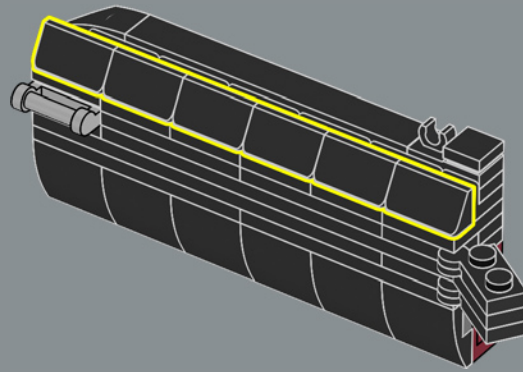

180

181

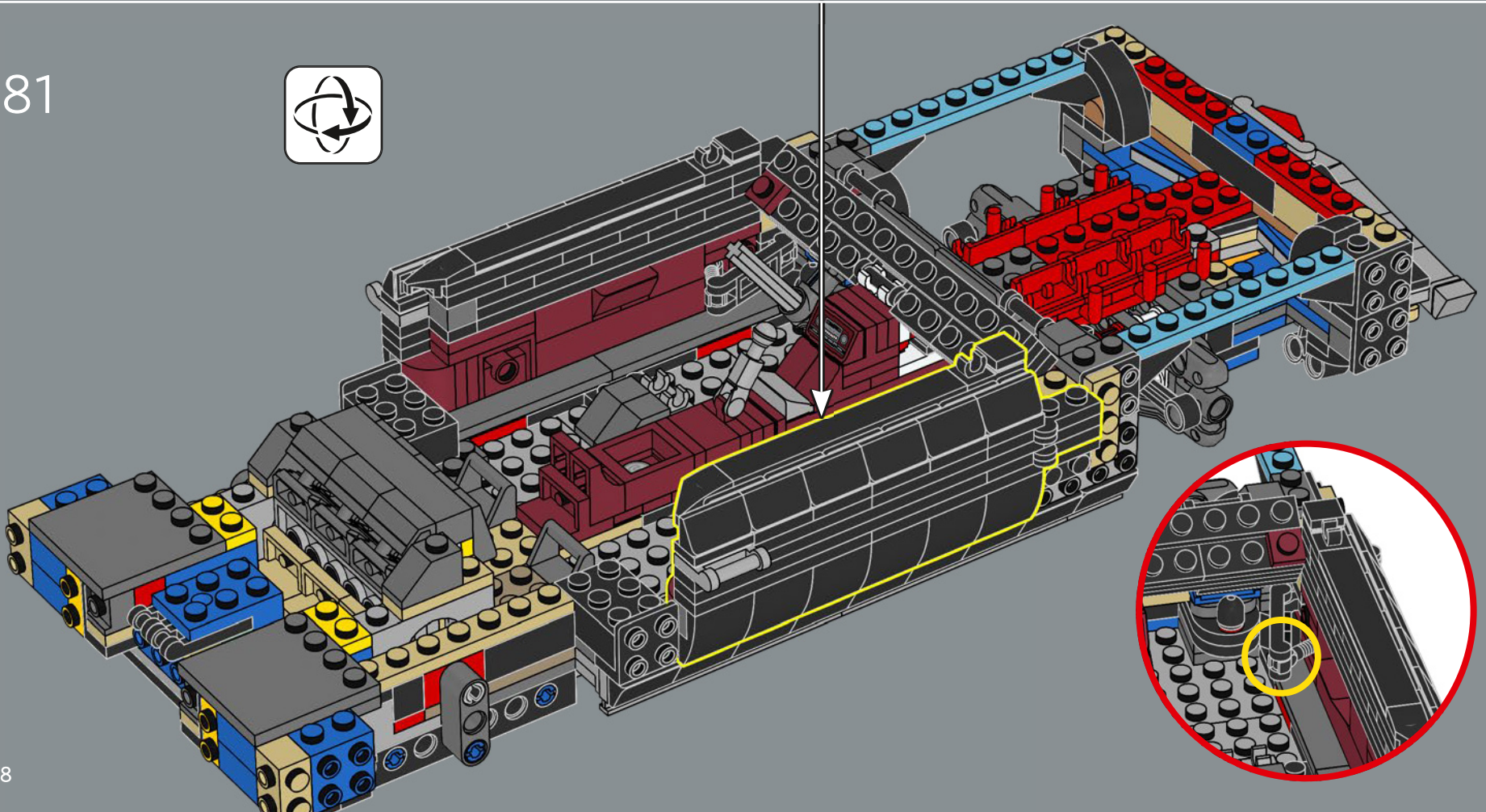



Tra tutti i modelli e le varianti, gli acquirenti della Camaro originale avevano 80 diverse opzioni di fabbrica tra cui scegliere.

182

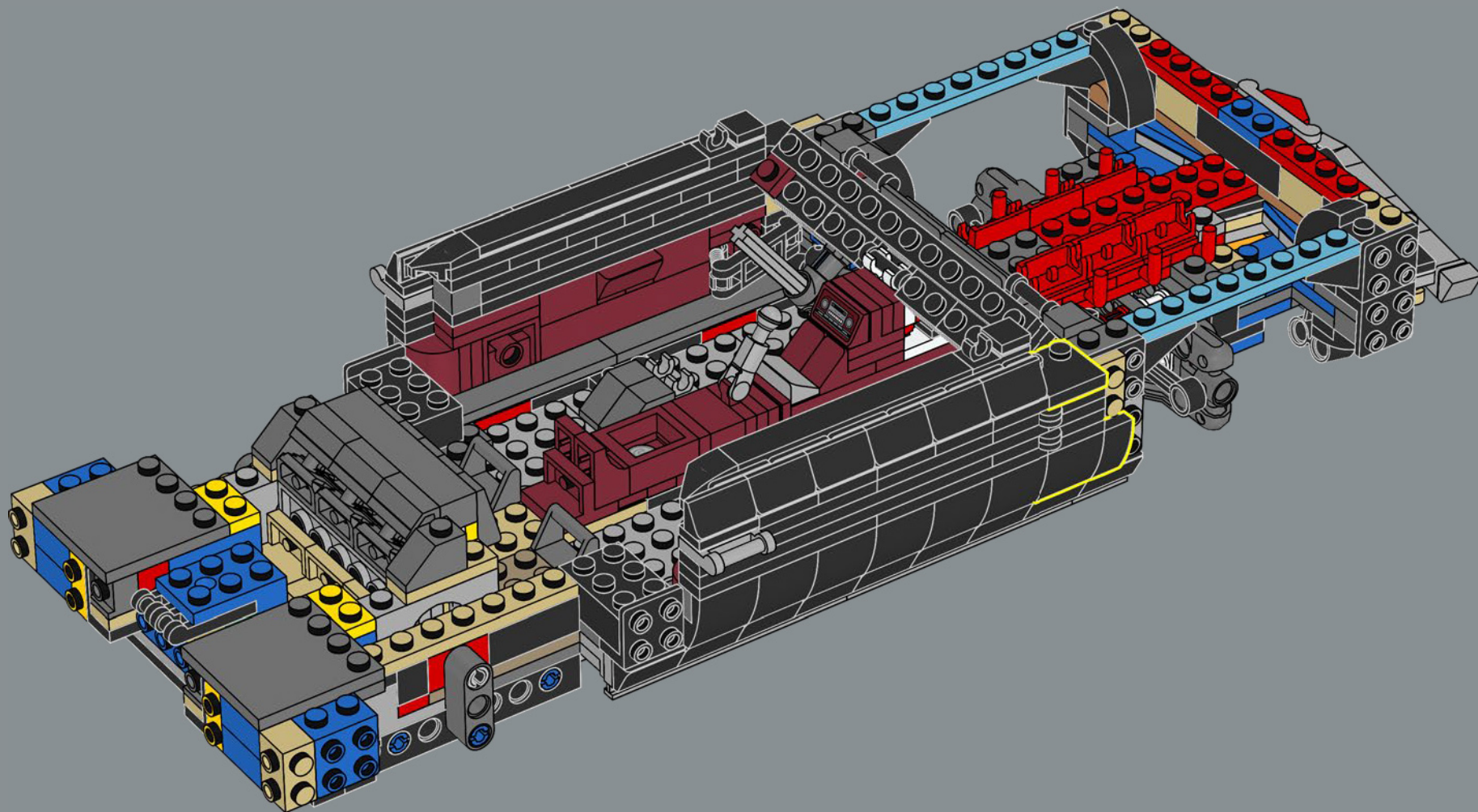

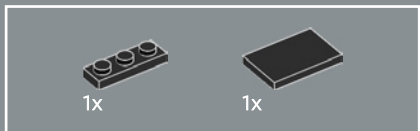

183

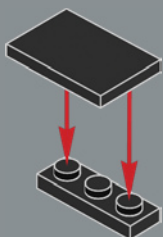

184

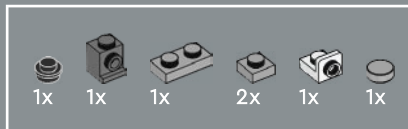
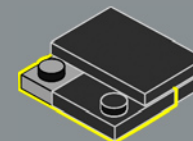

185

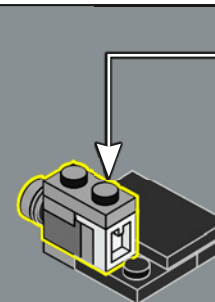
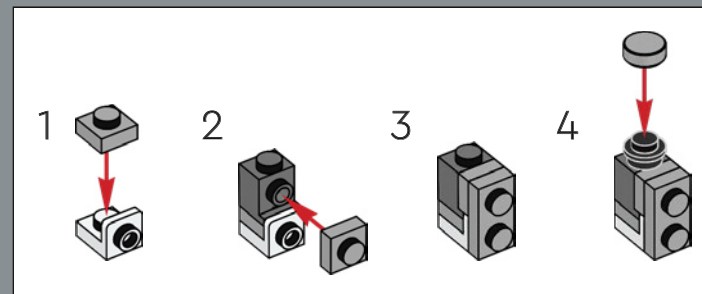

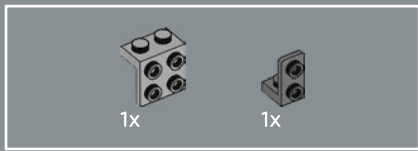

186

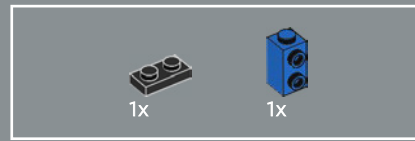
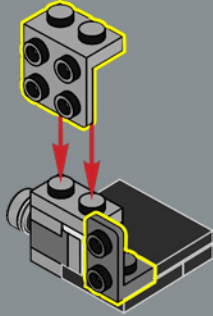

187

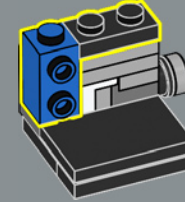

188

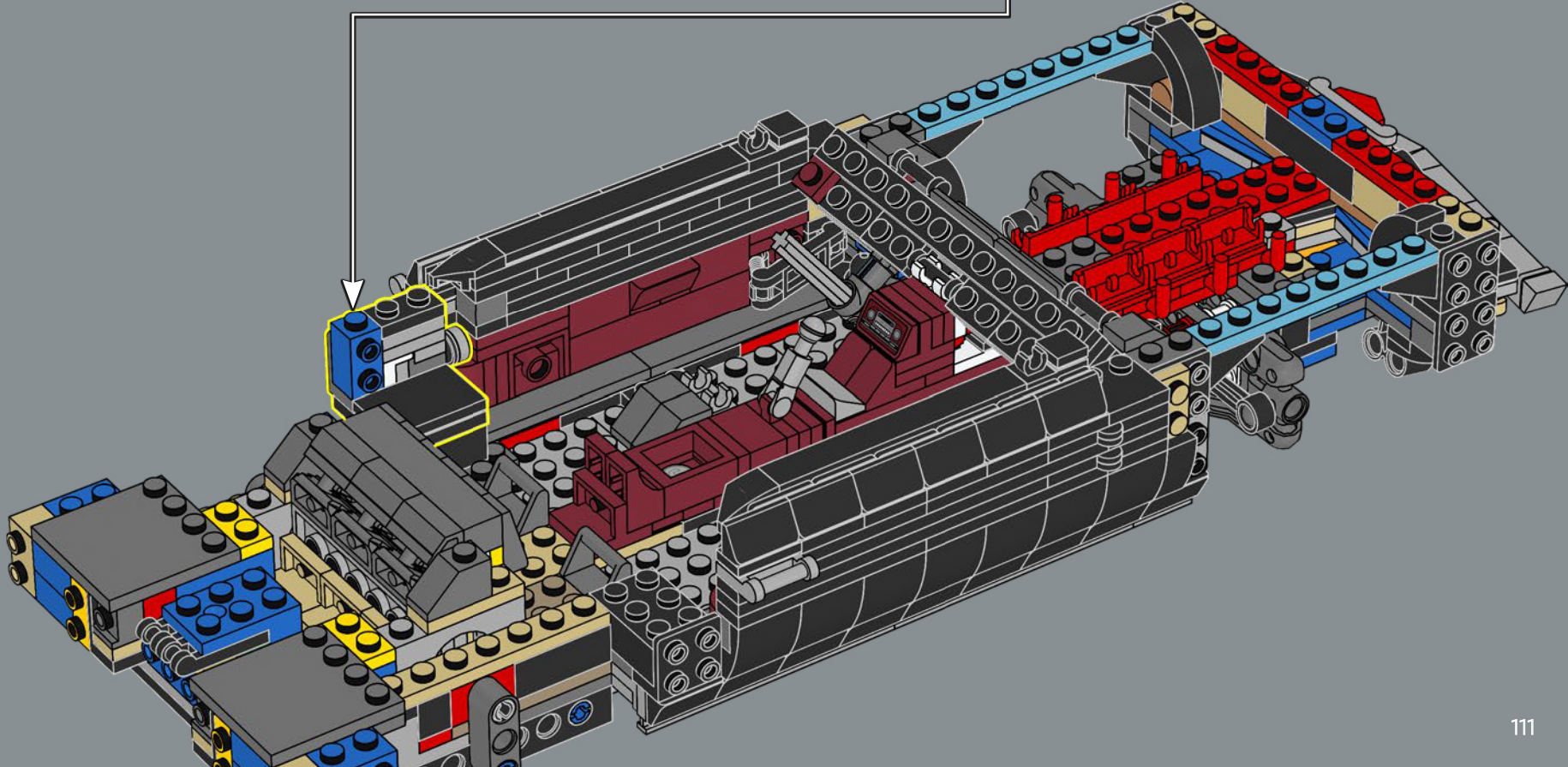

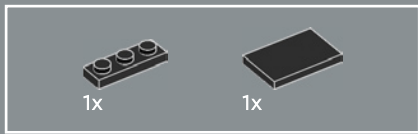

189

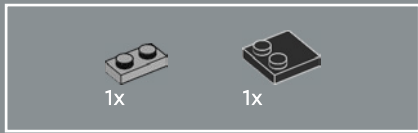
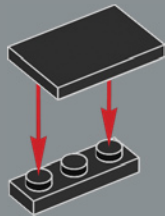

190

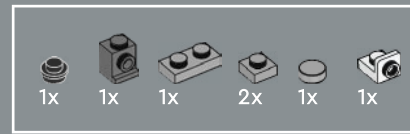
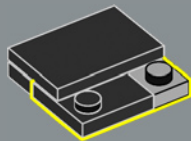

191

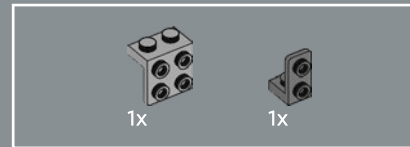
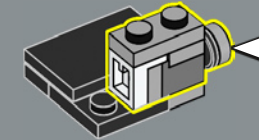
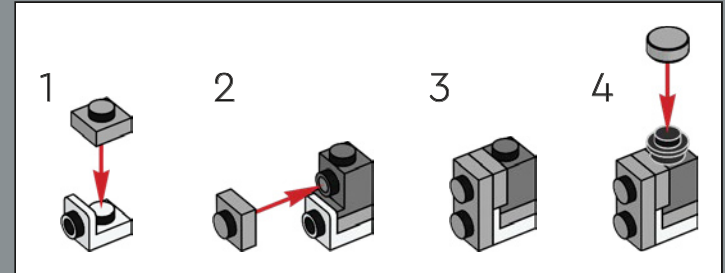

192

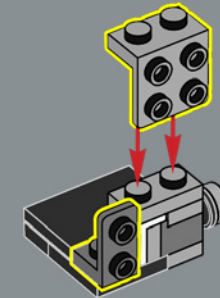

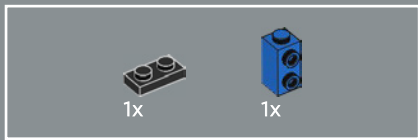

193

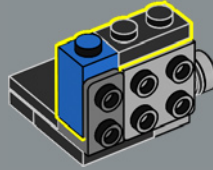

194

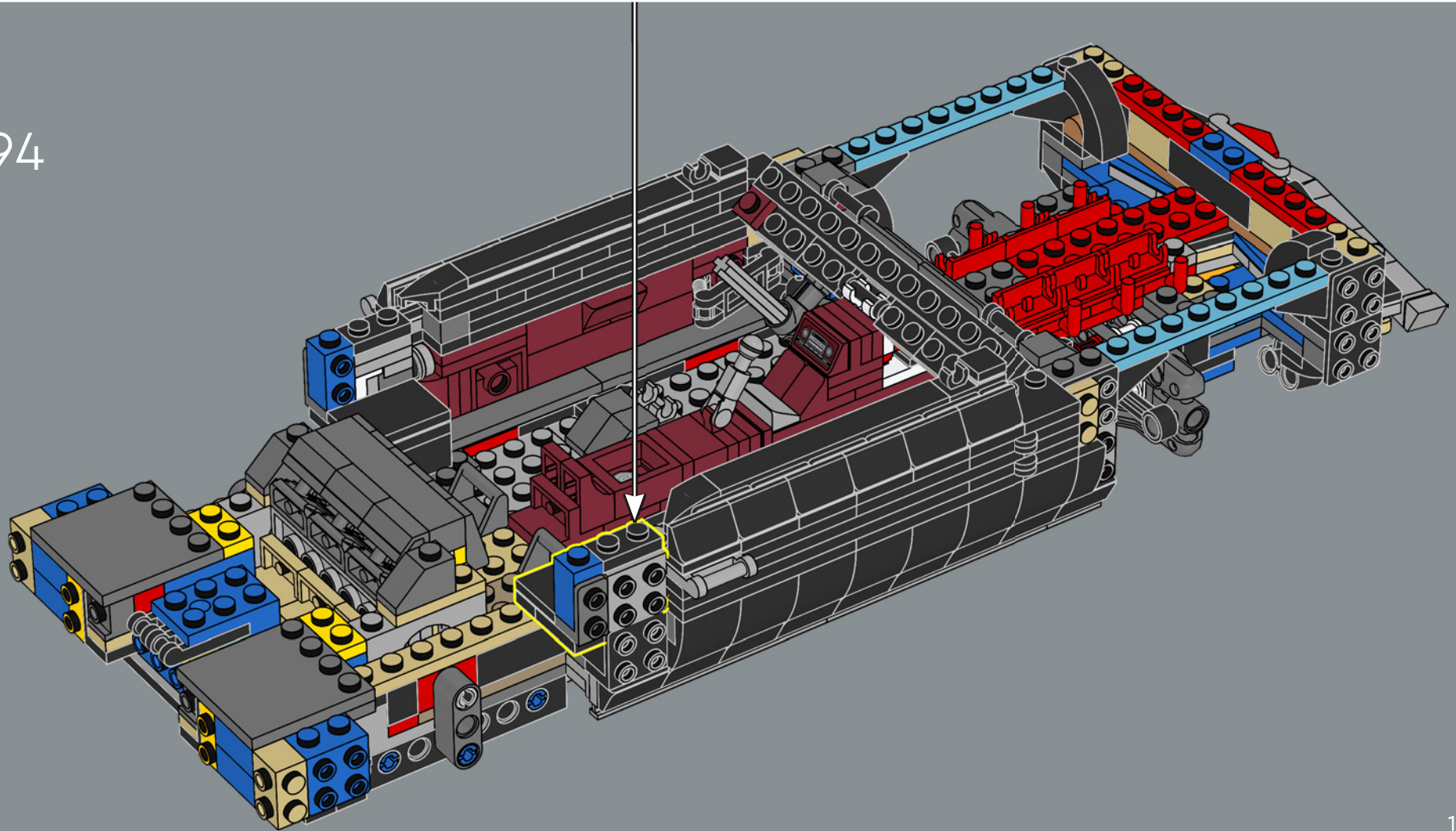

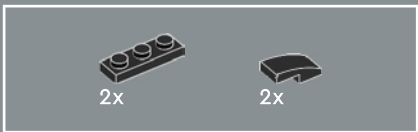

195

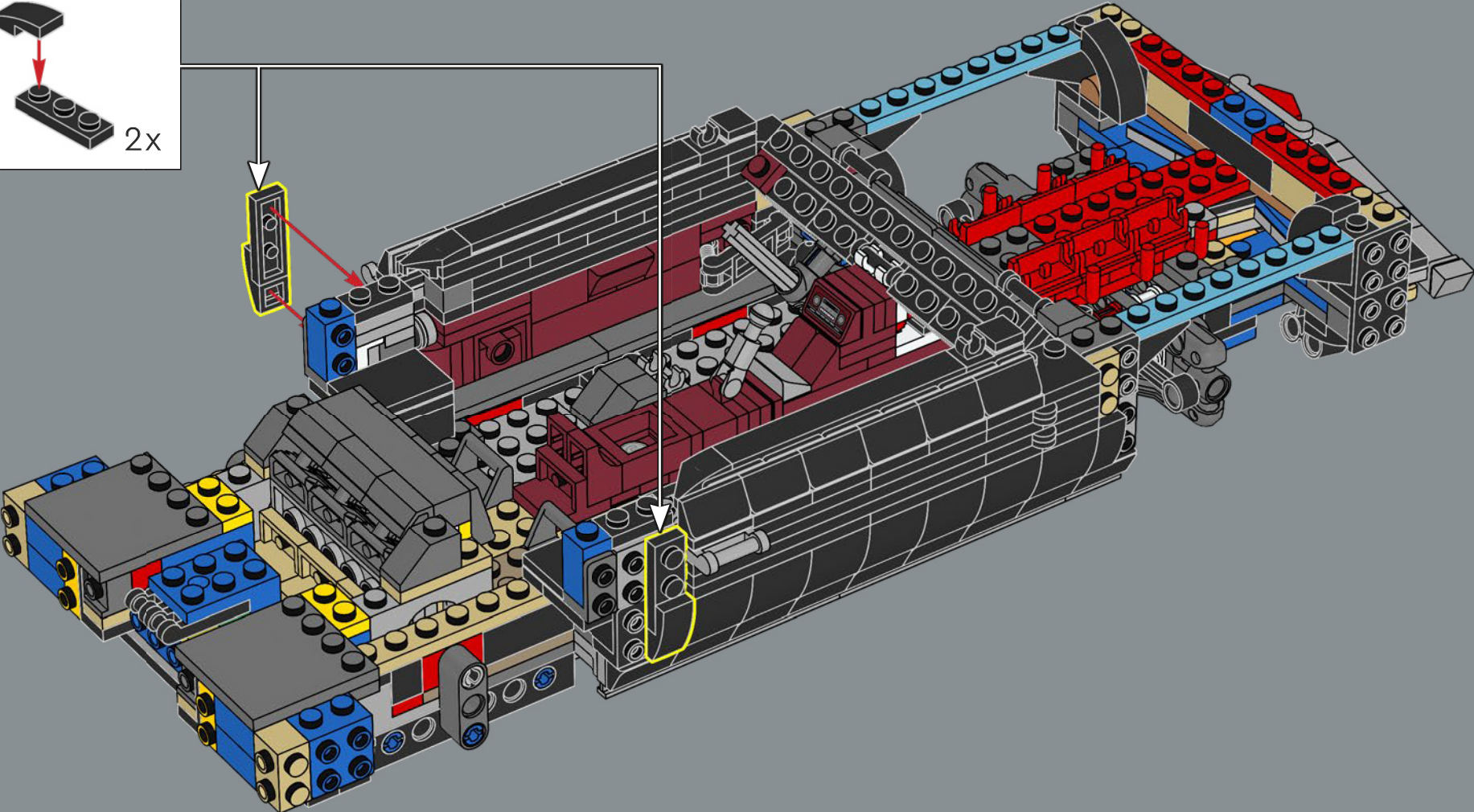
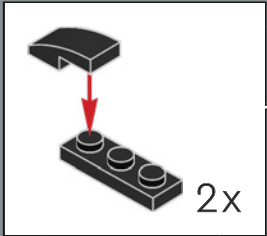

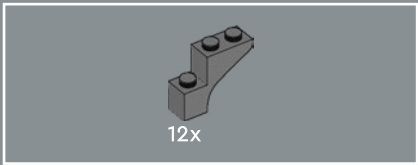

196

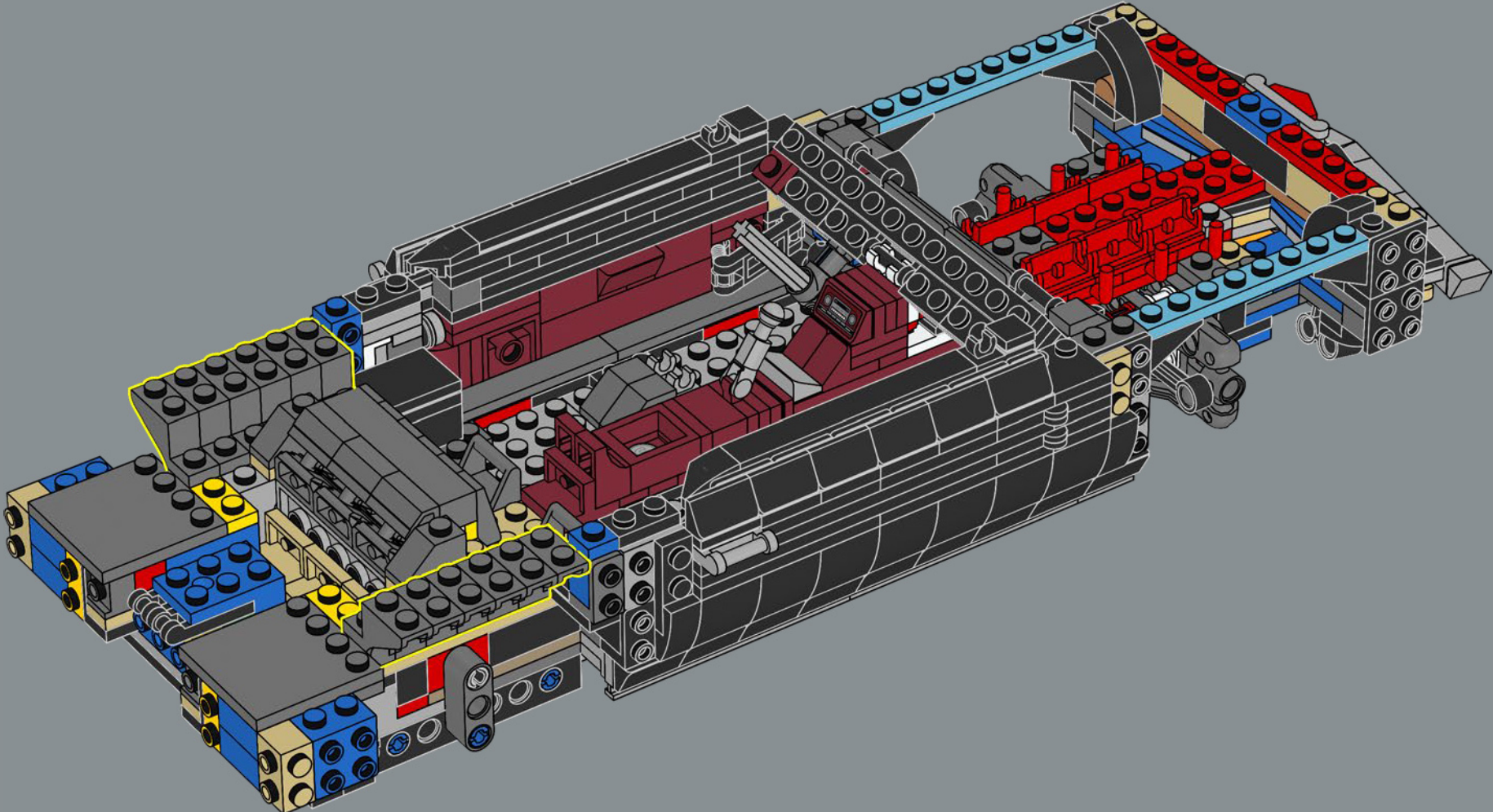

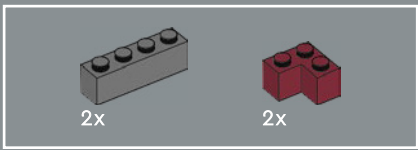

197

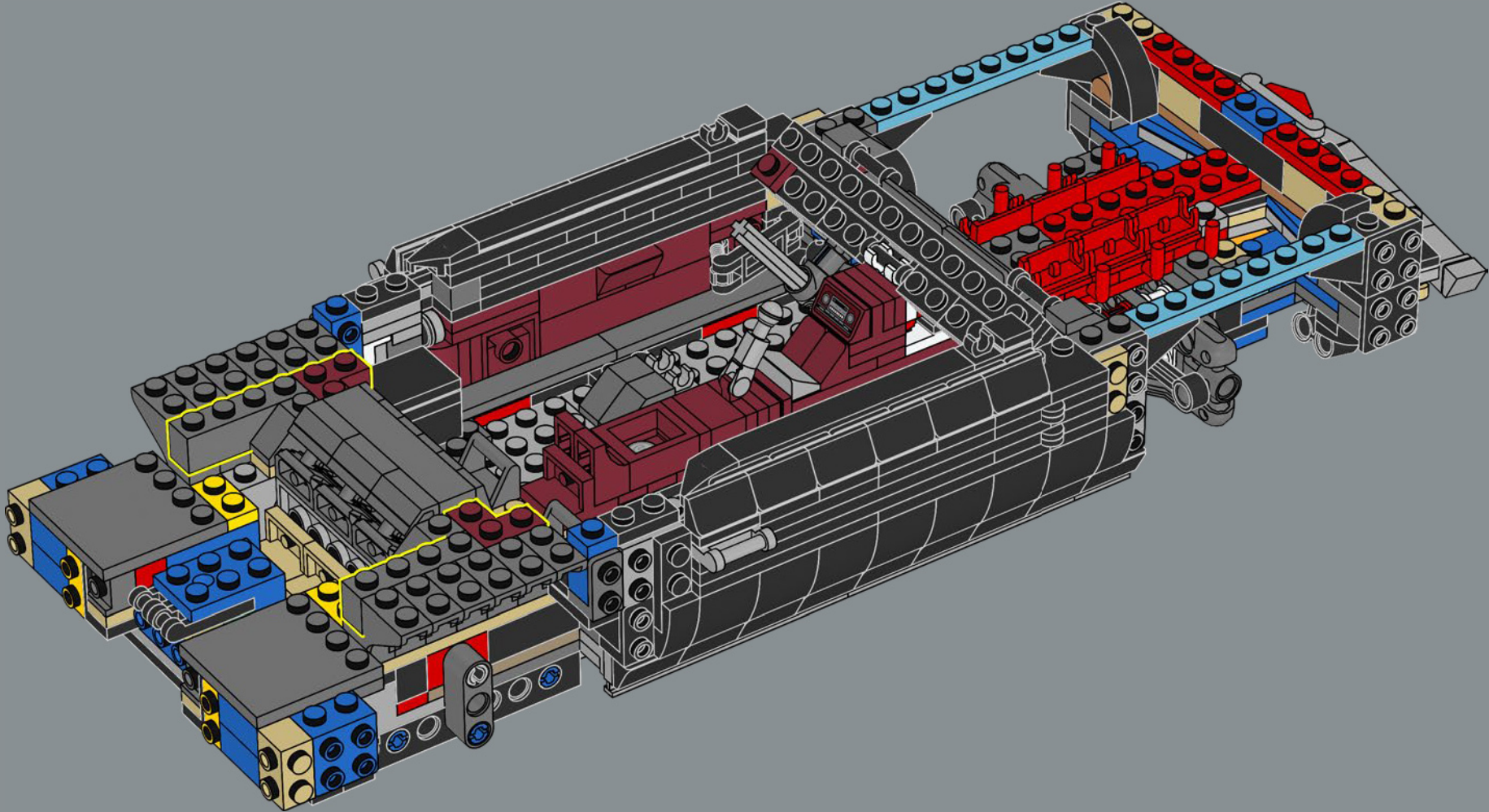

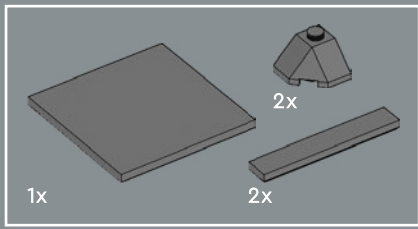

198

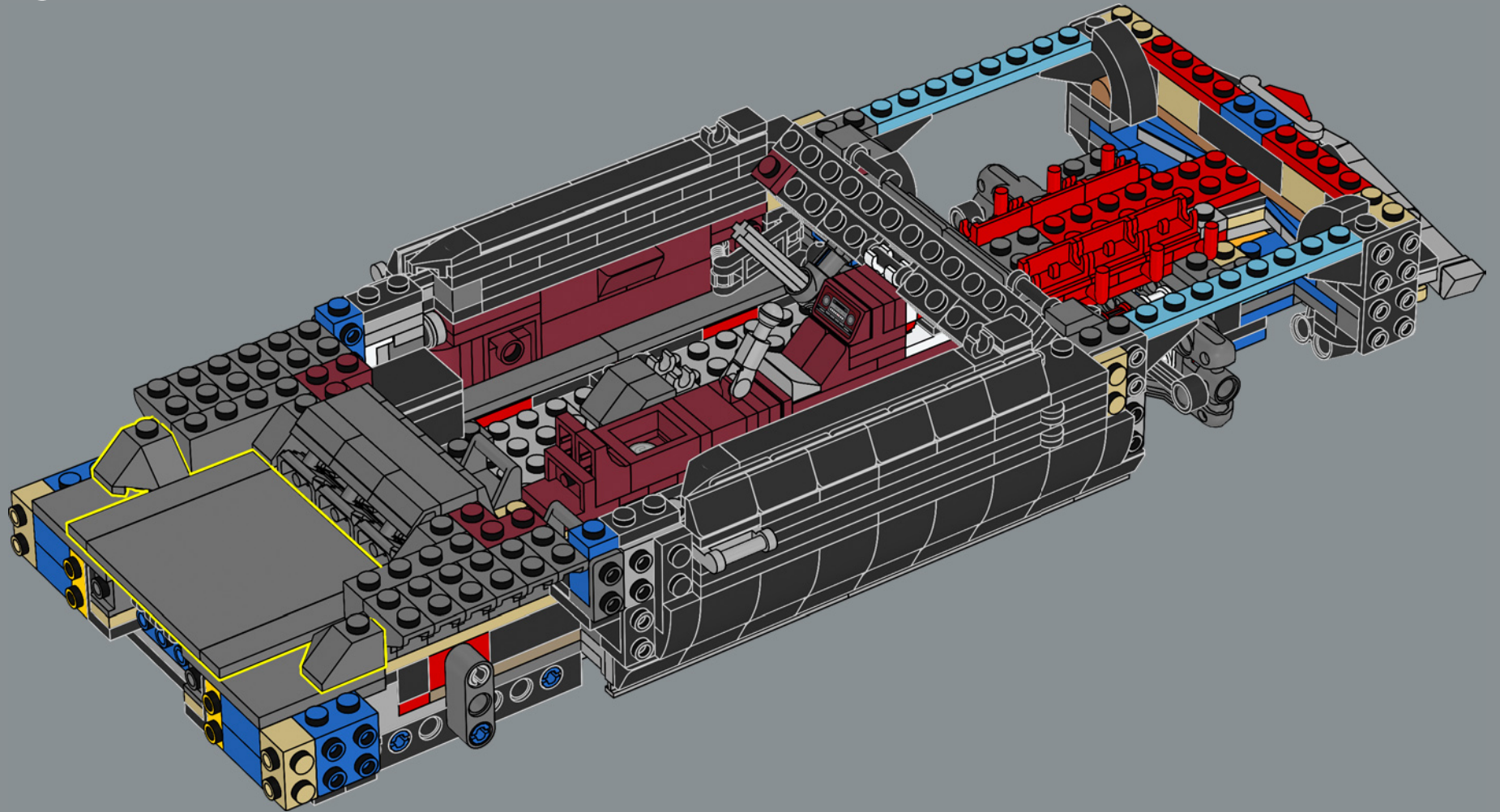

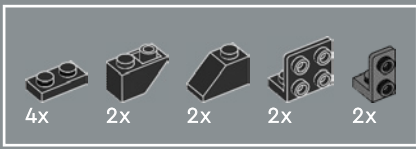

199

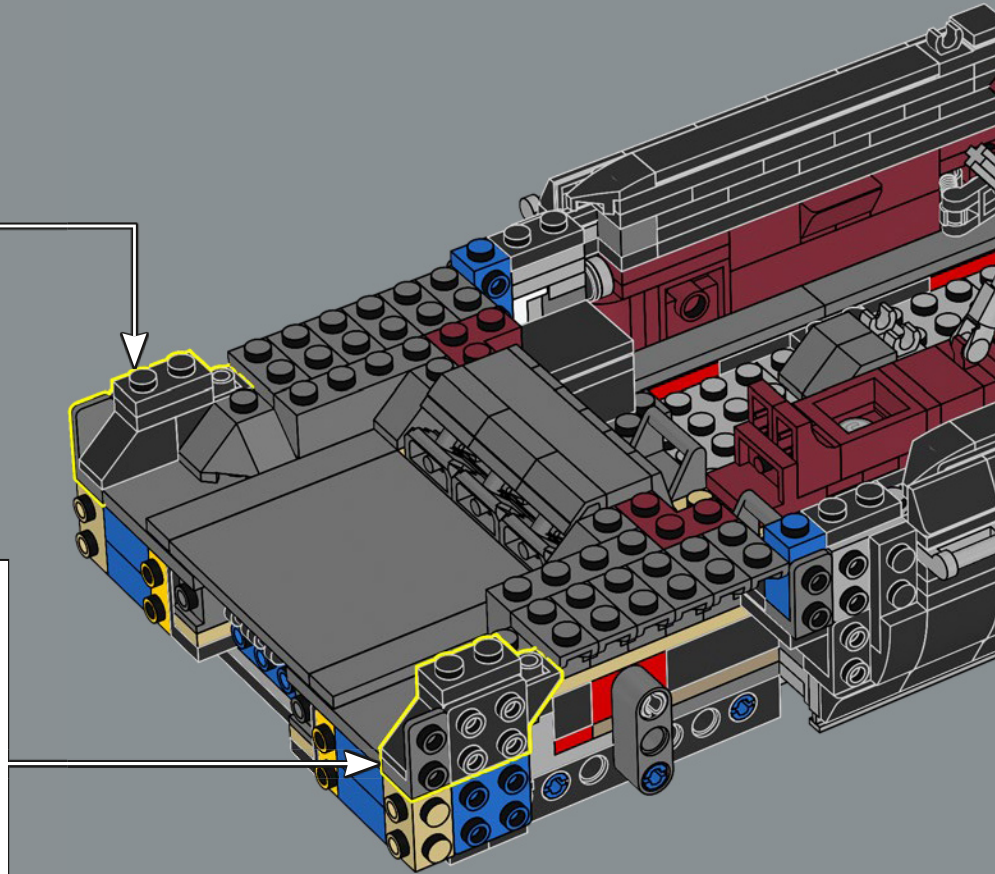
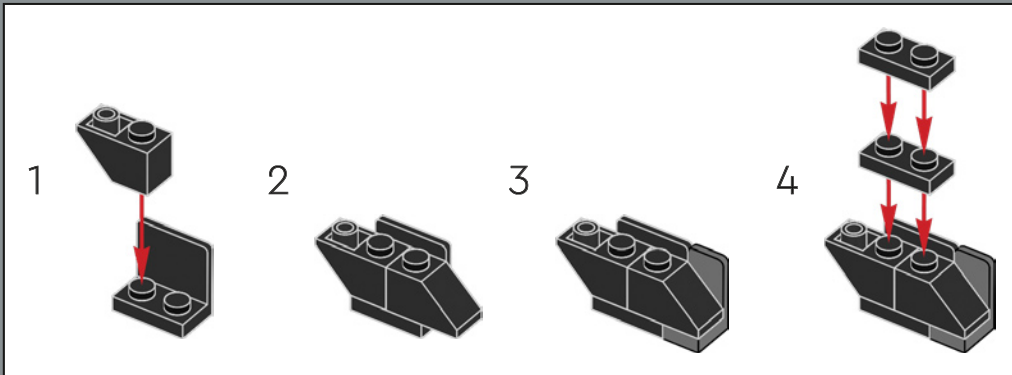
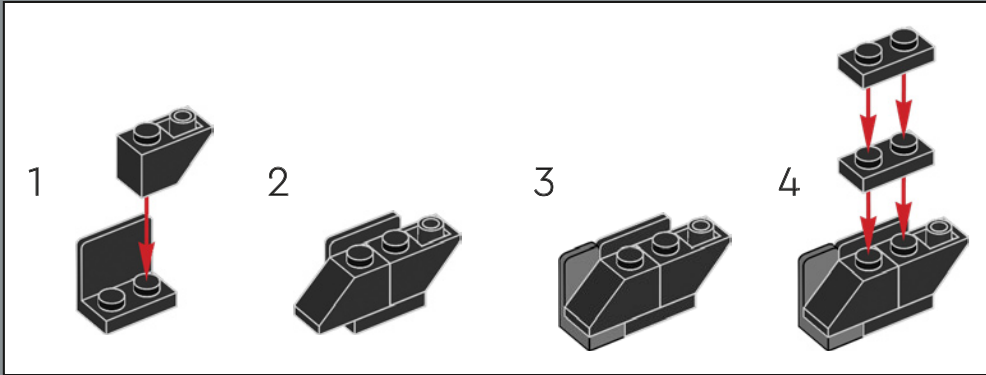

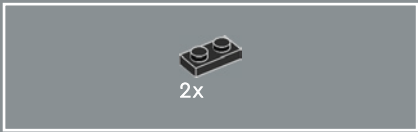

200

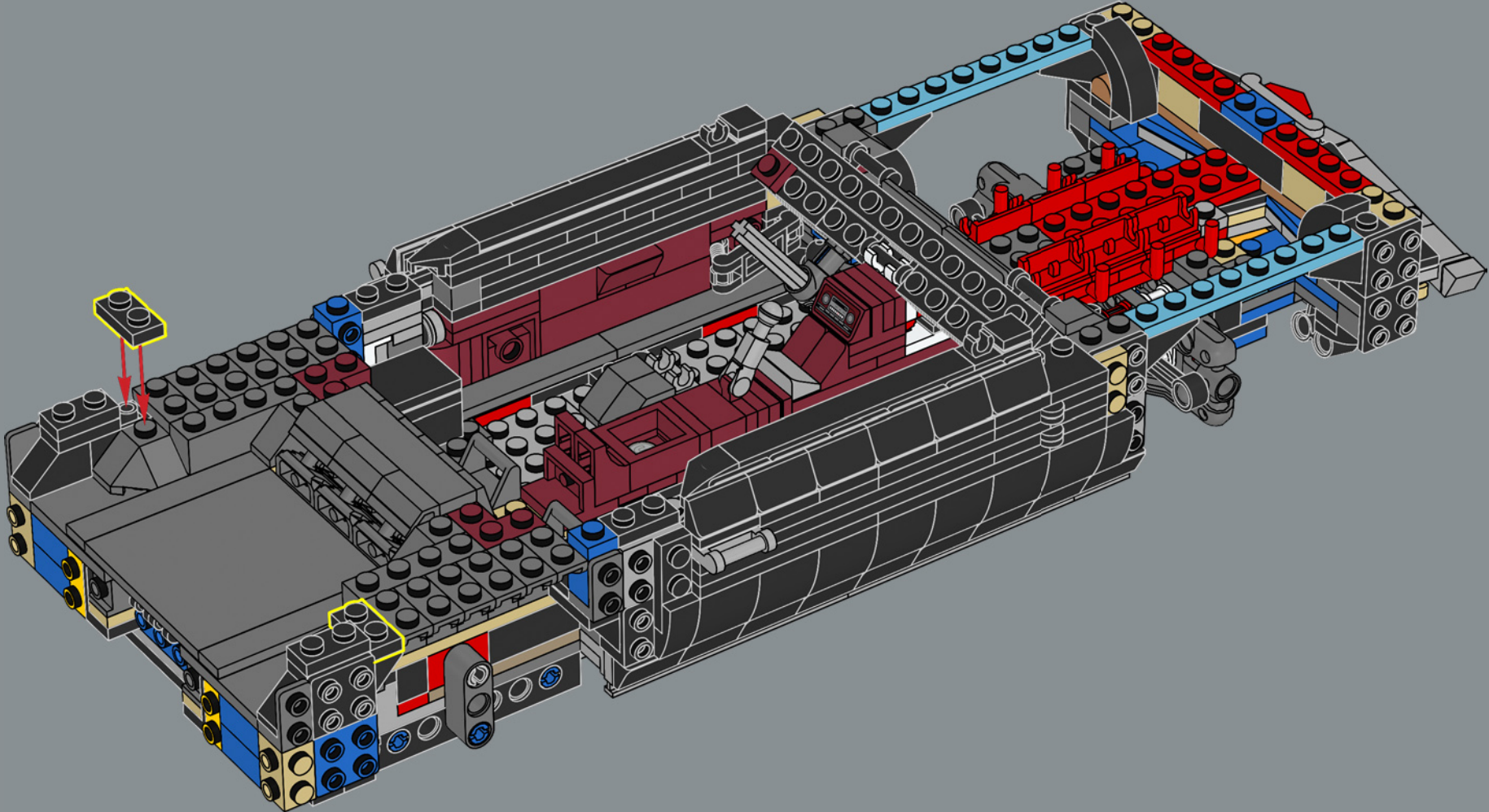



2x

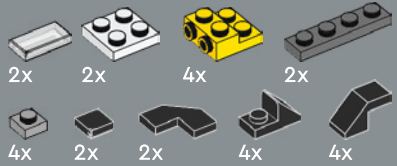

201

1

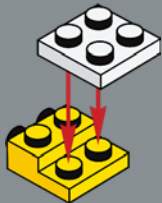

2

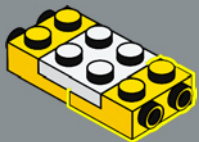

3

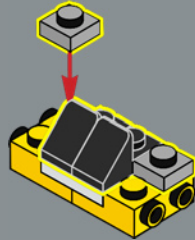

4

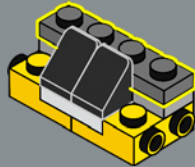

5

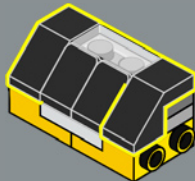

2x

6

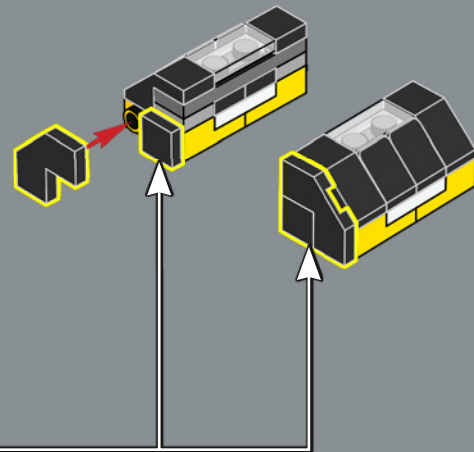

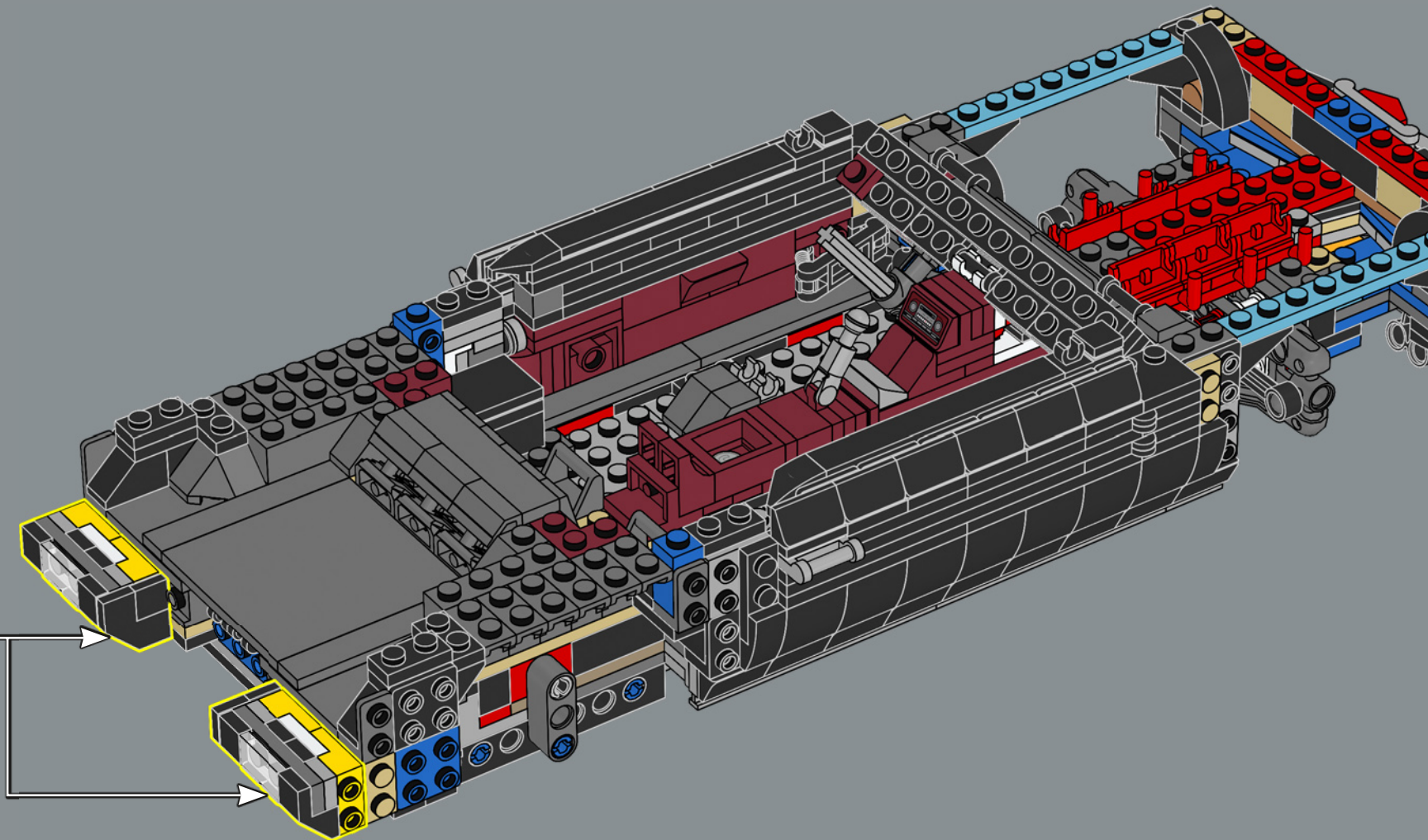



202

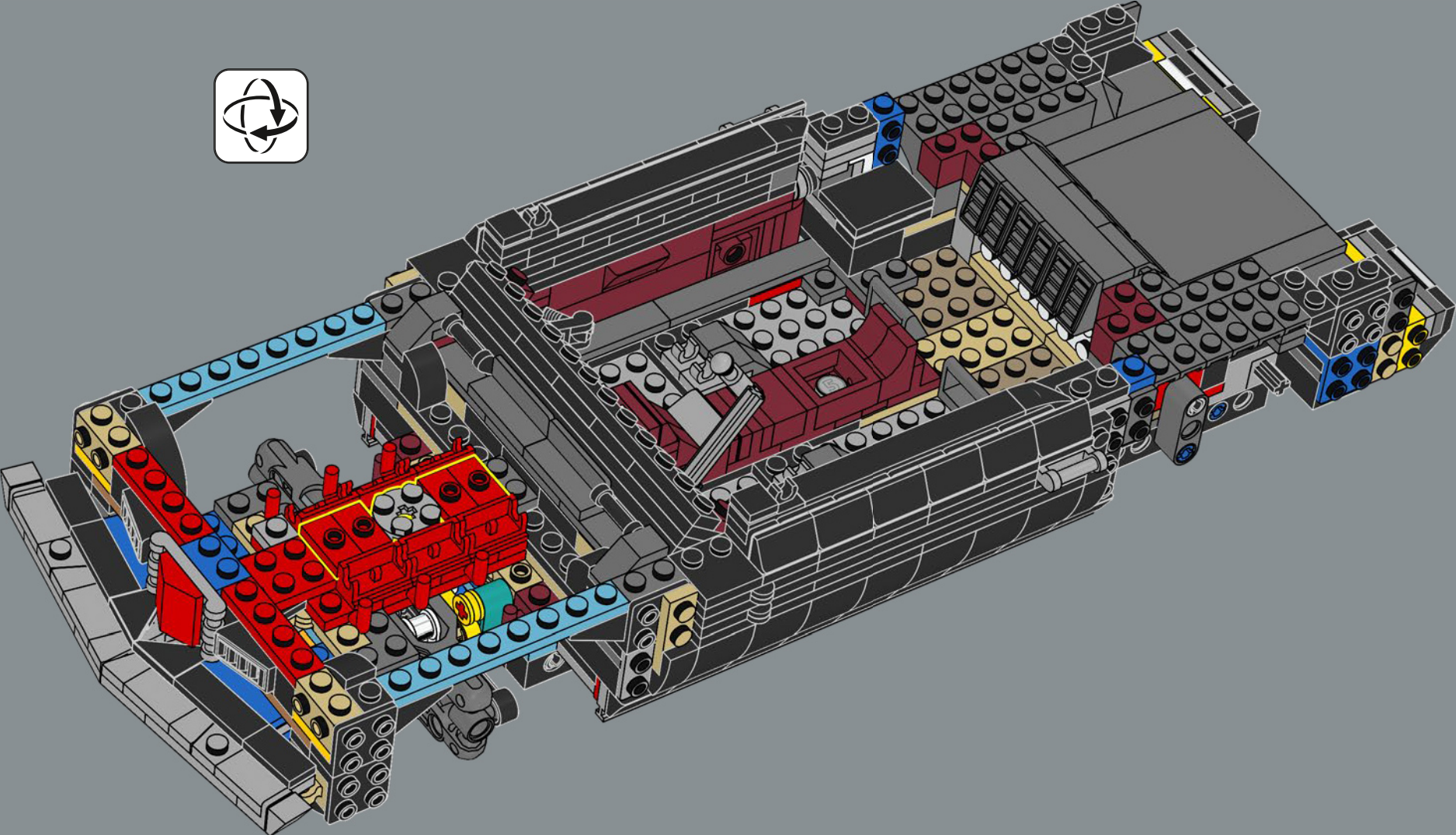

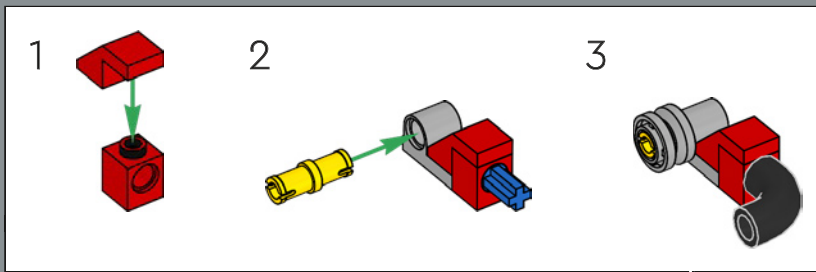
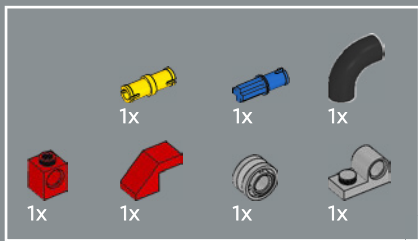

203

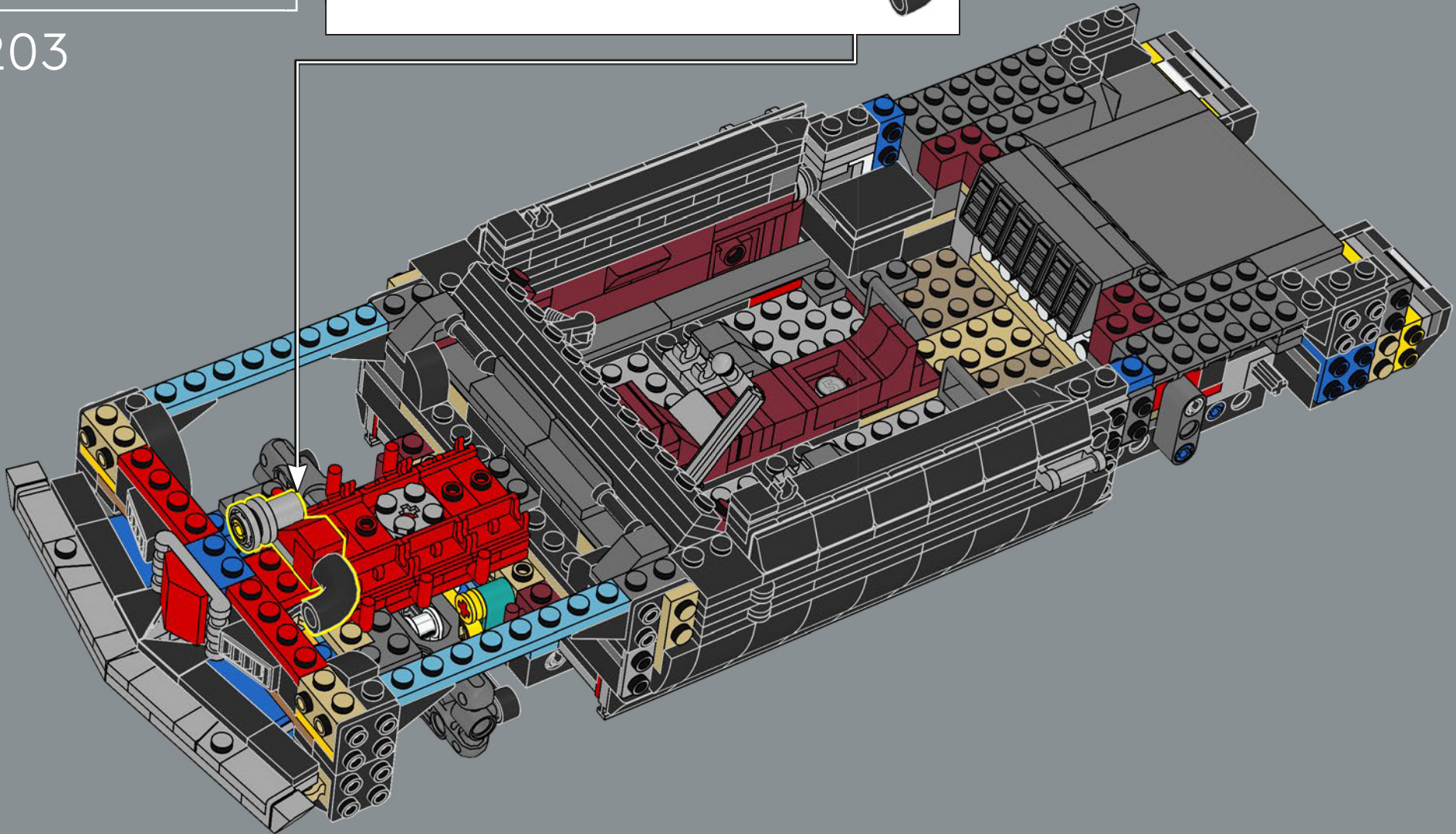

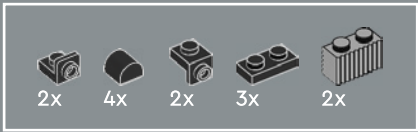

204

1

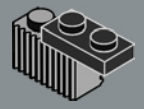

2

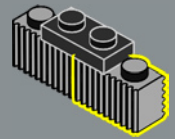

3

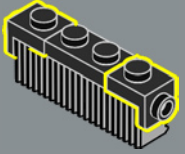

4

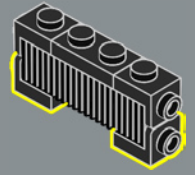

5

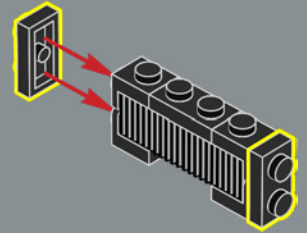

6

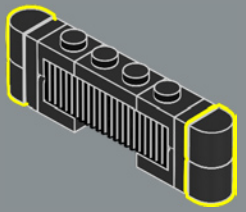

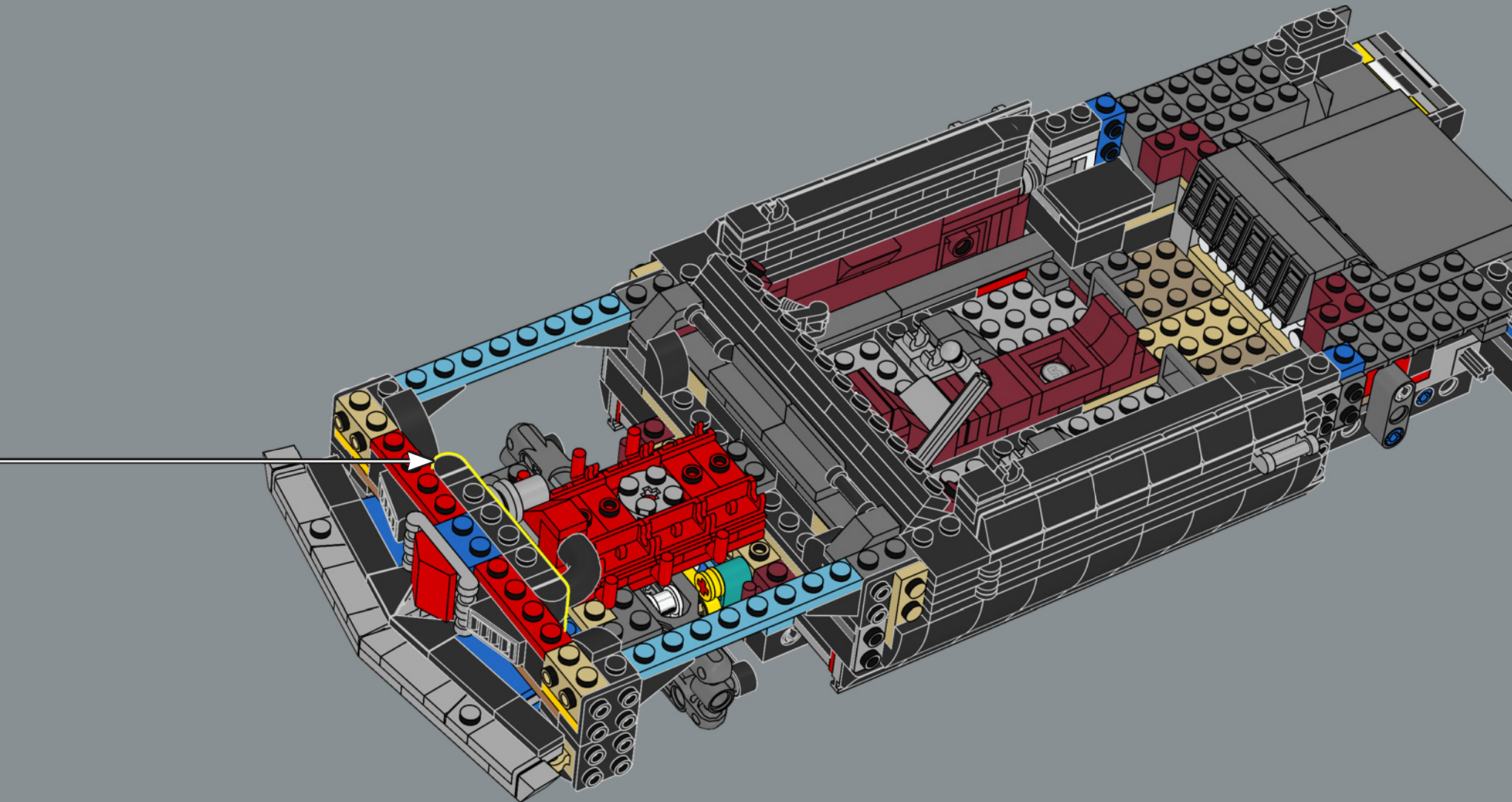

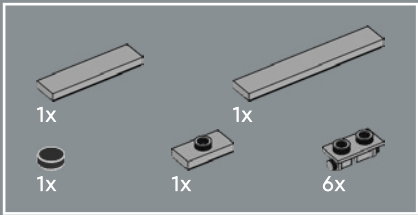

205

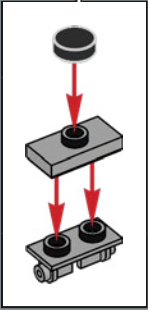
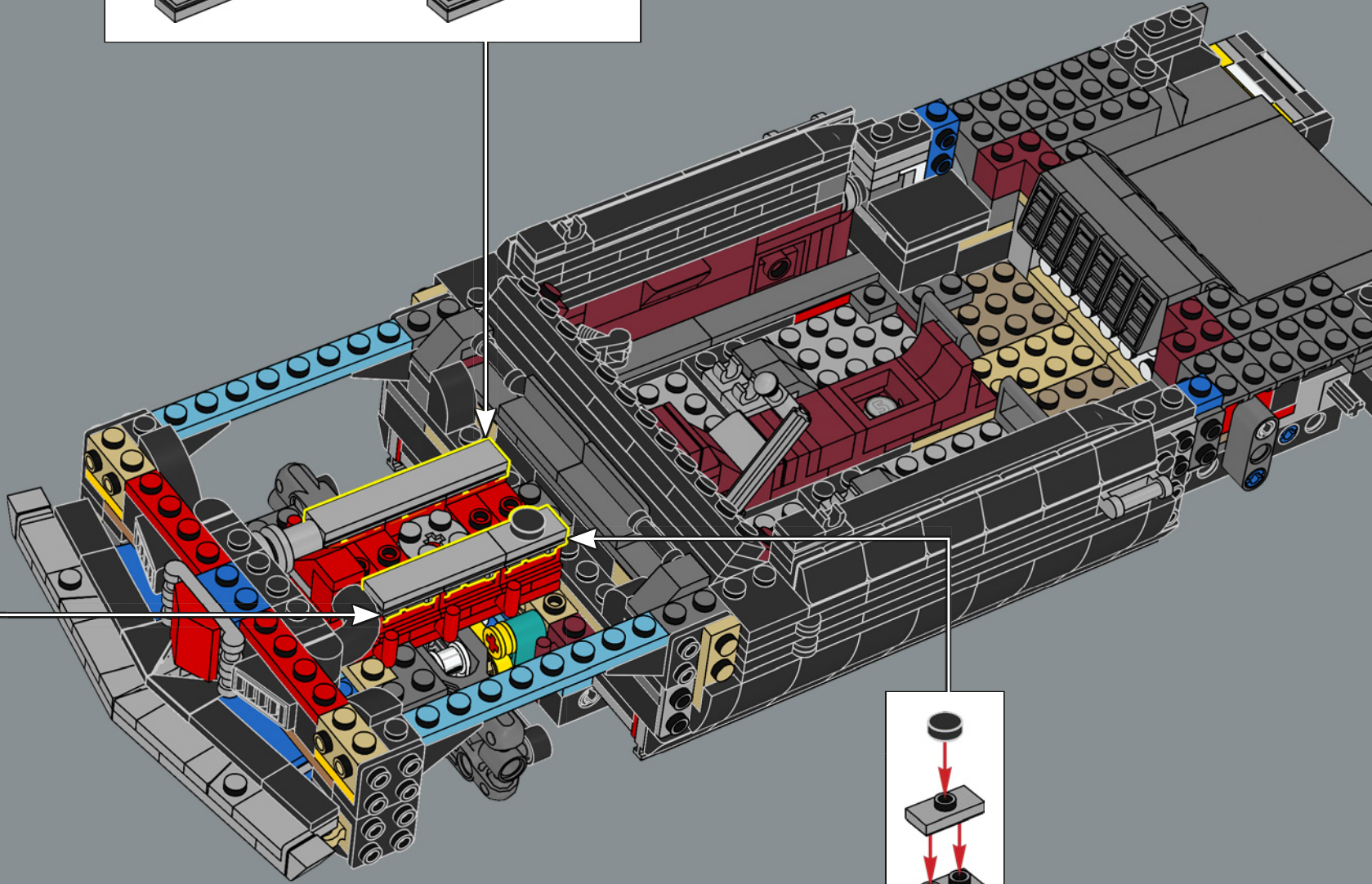
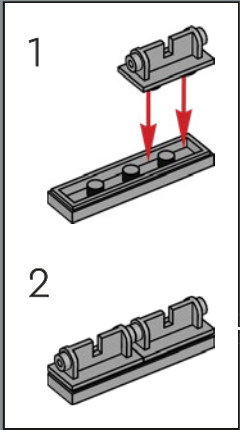
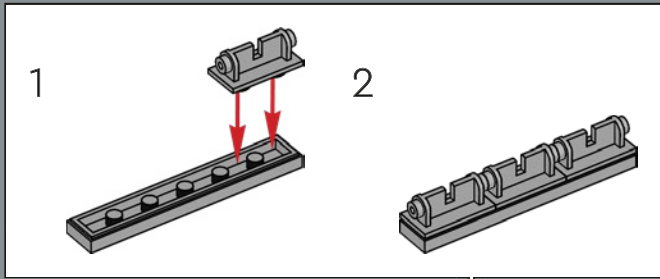

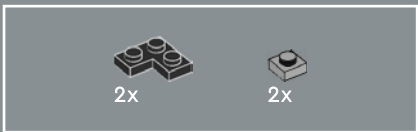

206

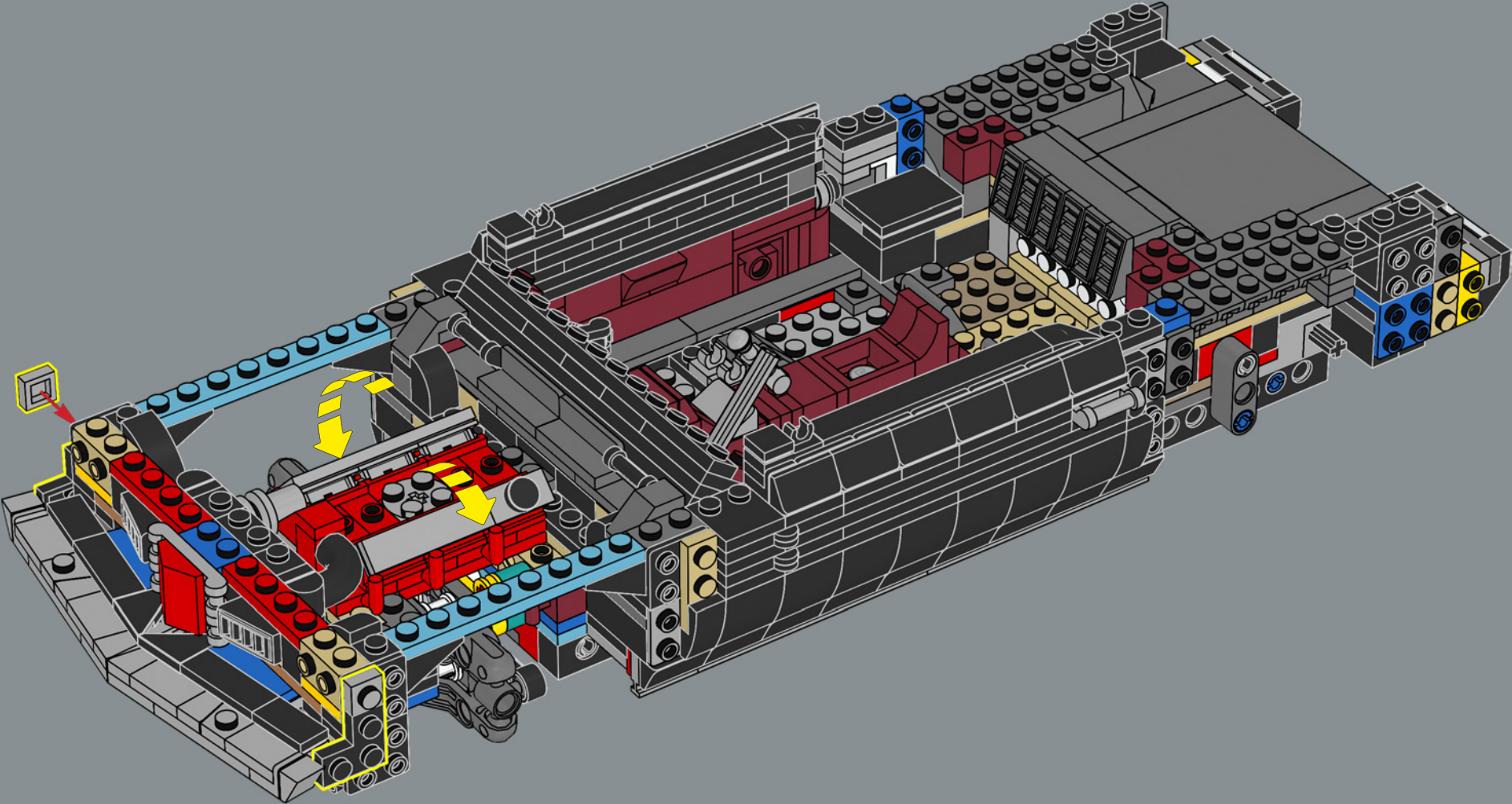



207

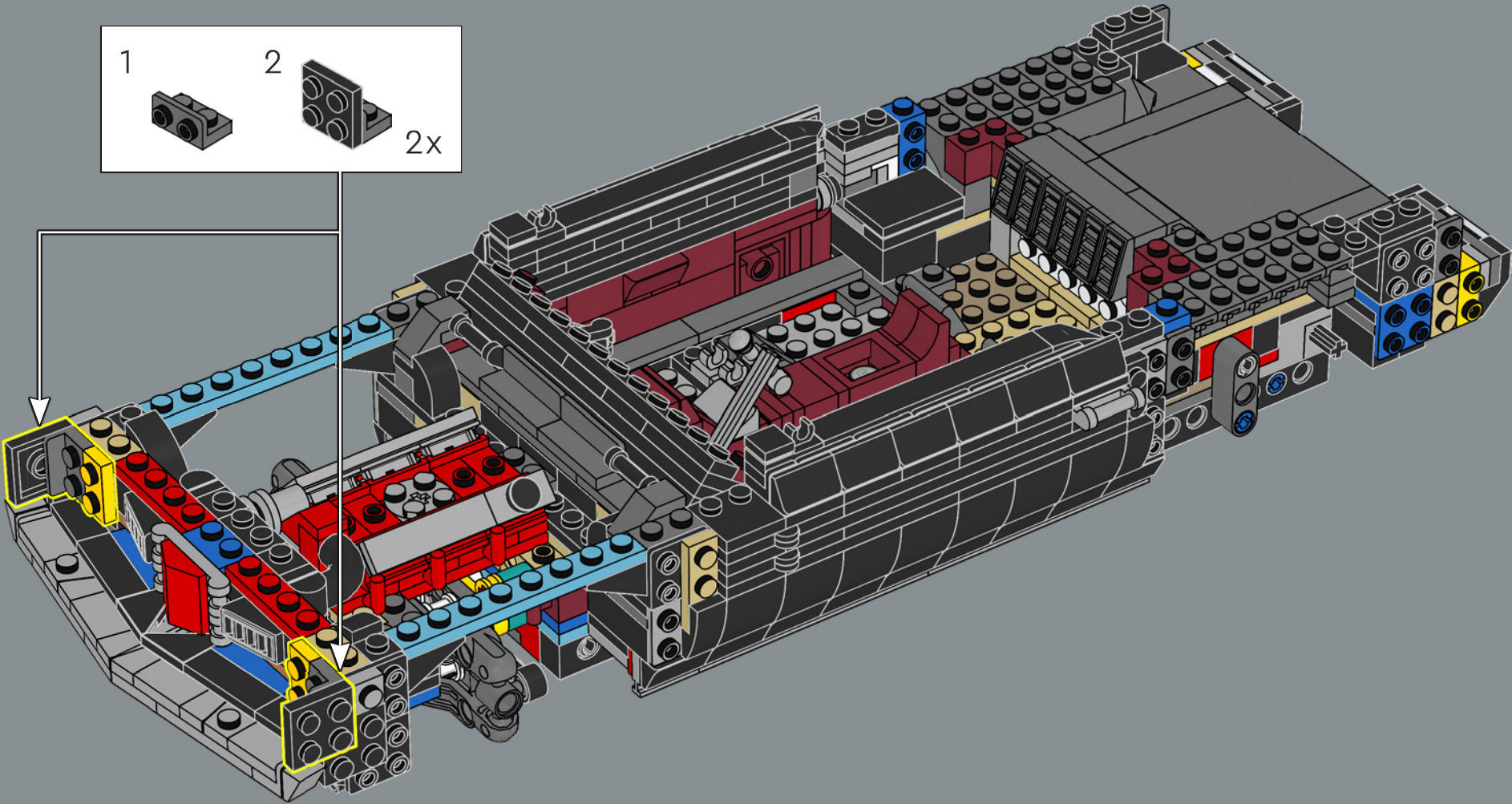
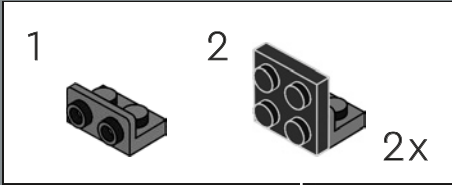

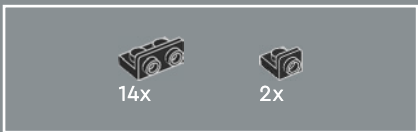

208

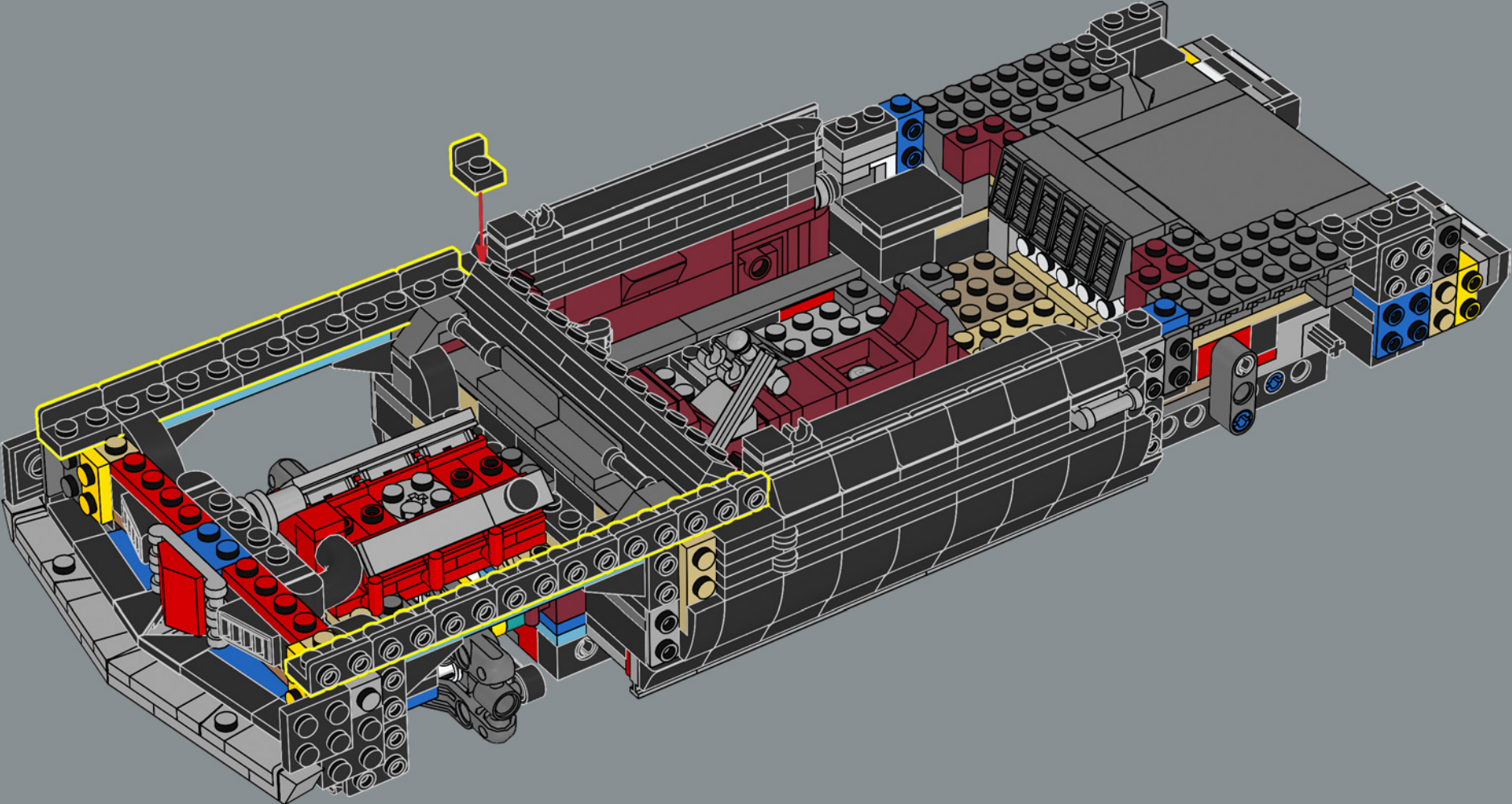

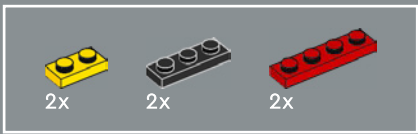

209

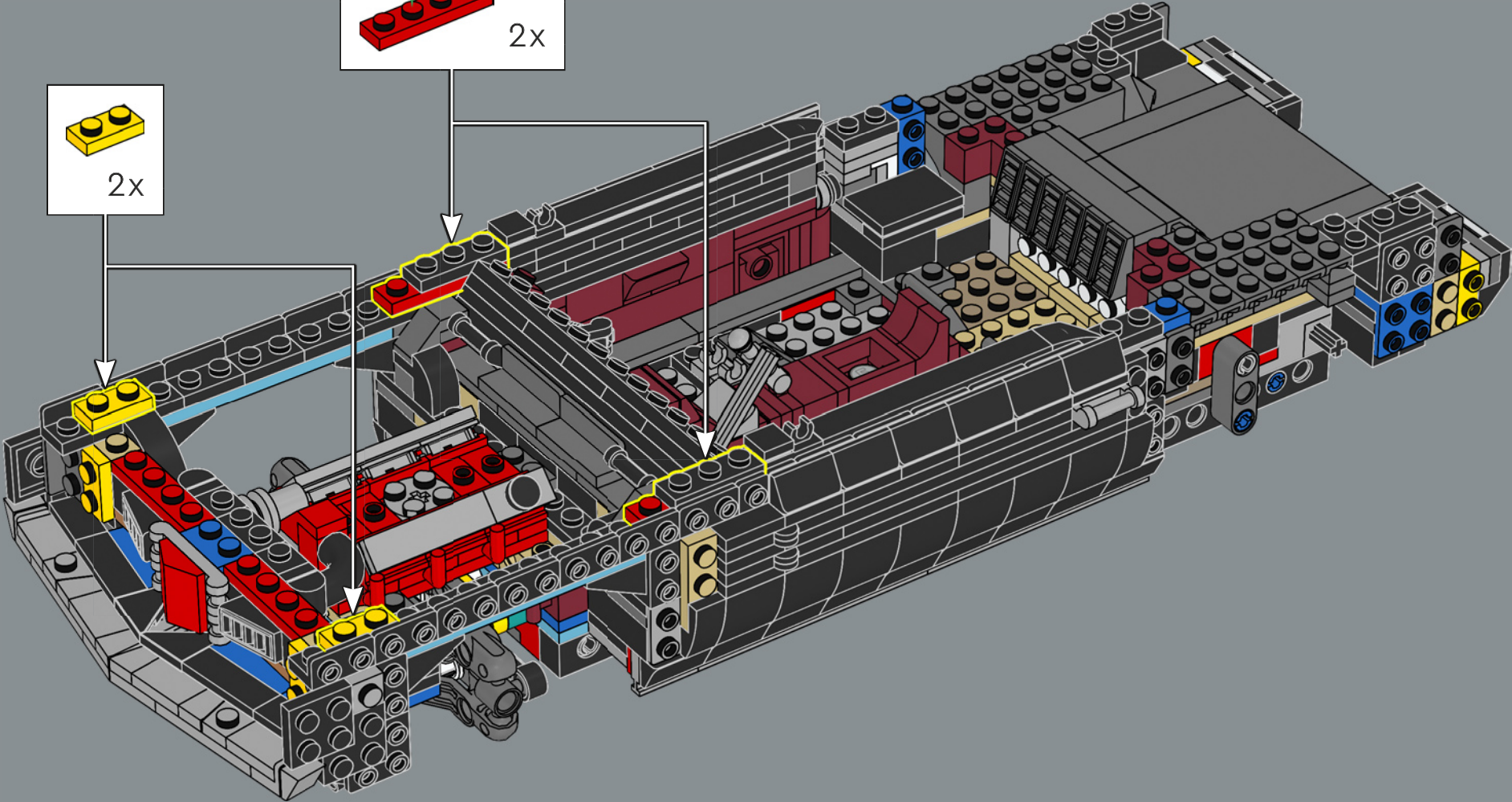
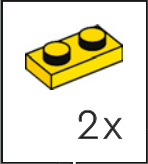
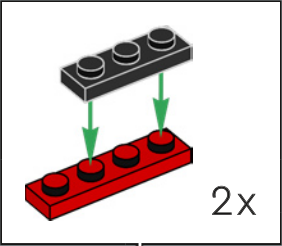



210

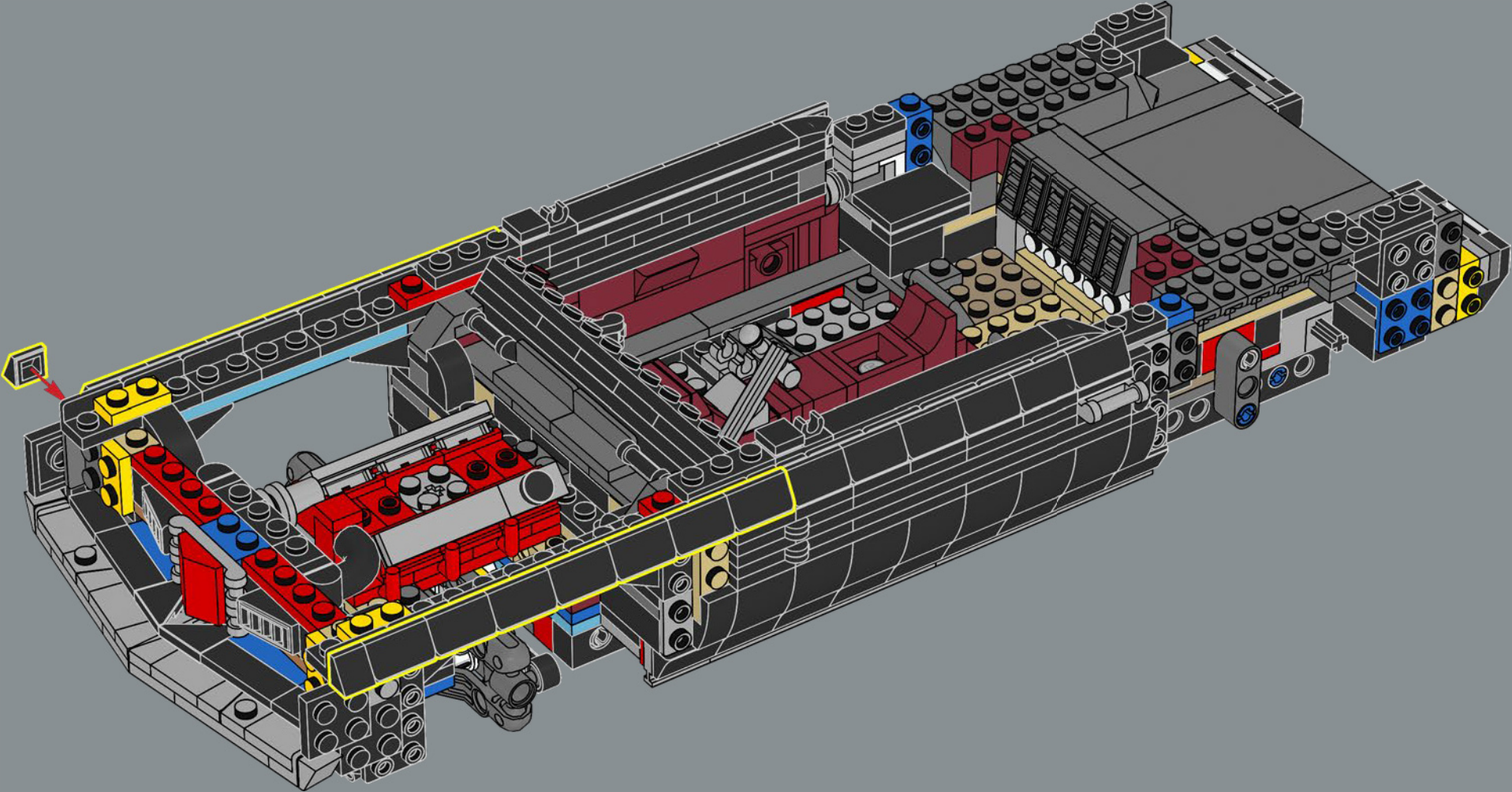

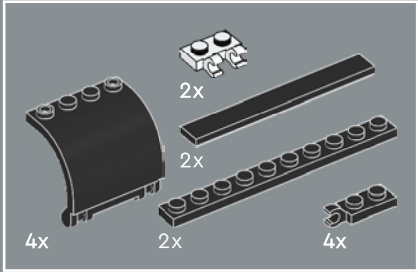
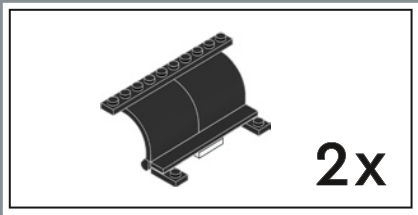

211

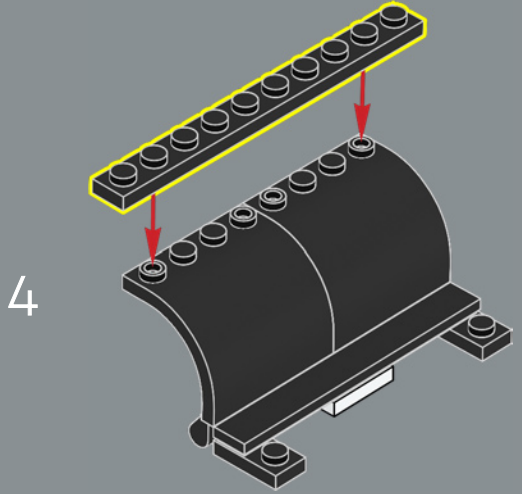
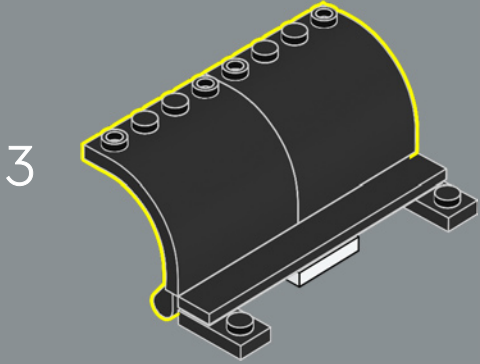
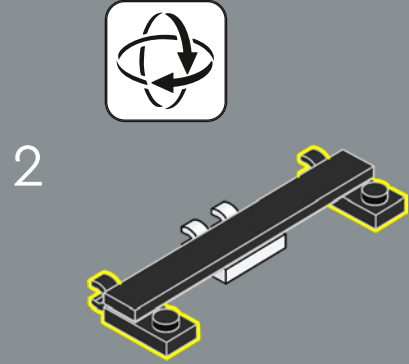
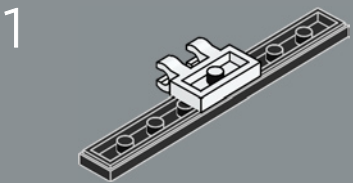

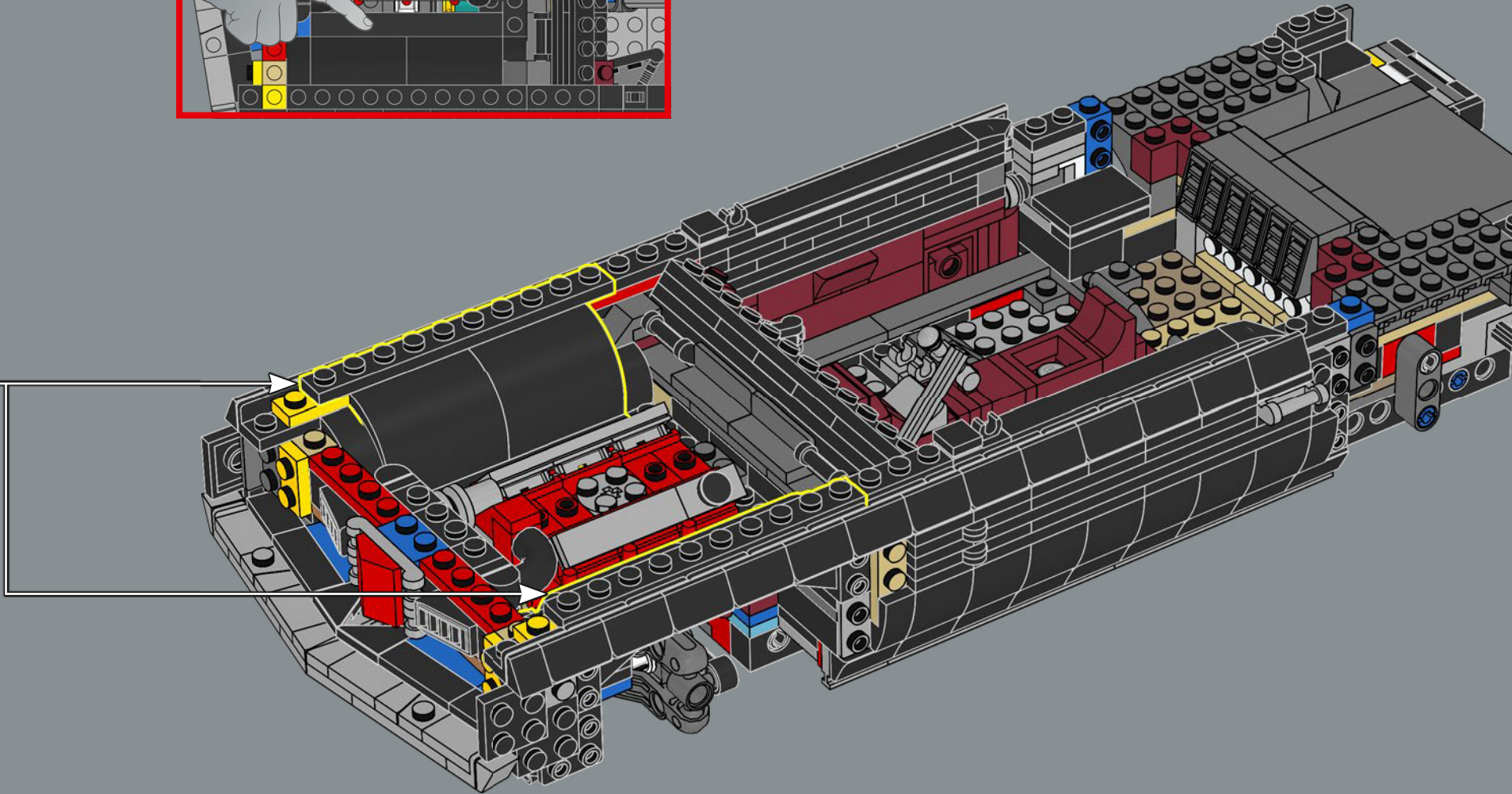
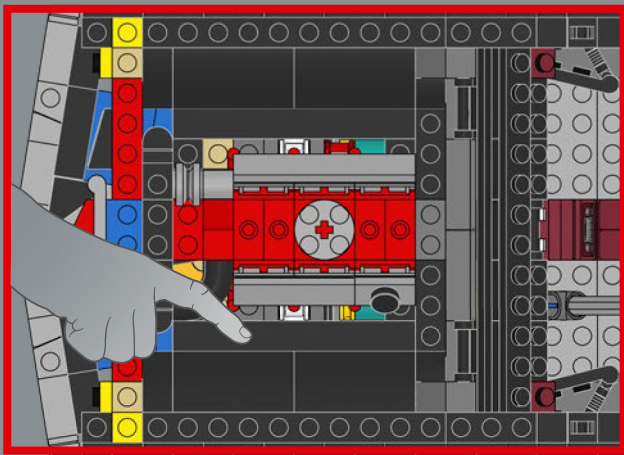

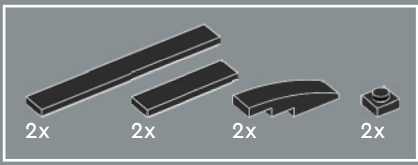

212

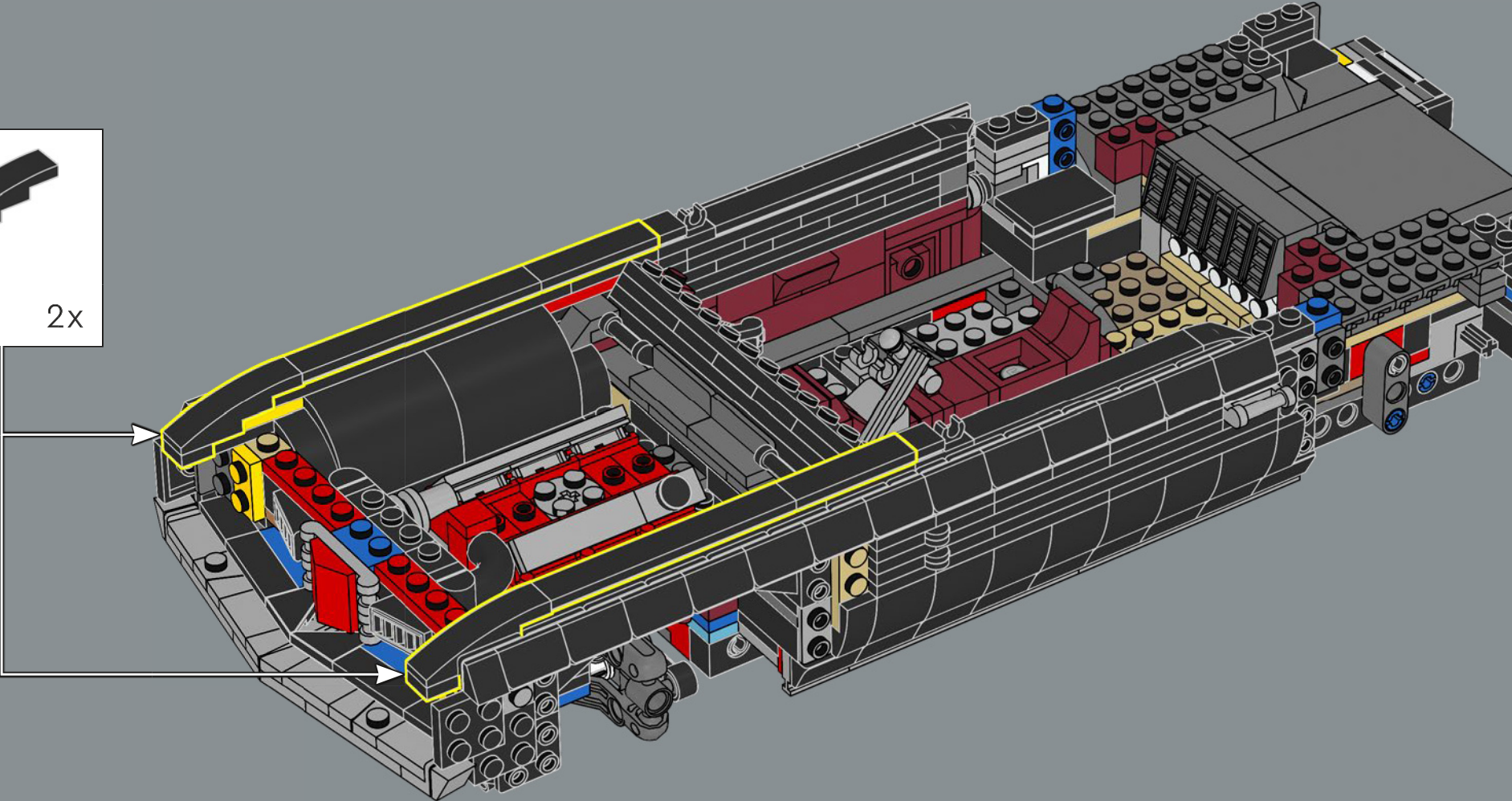
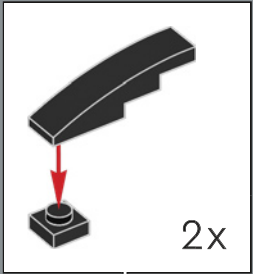

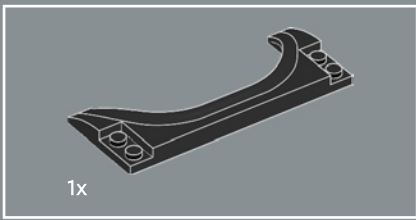

213

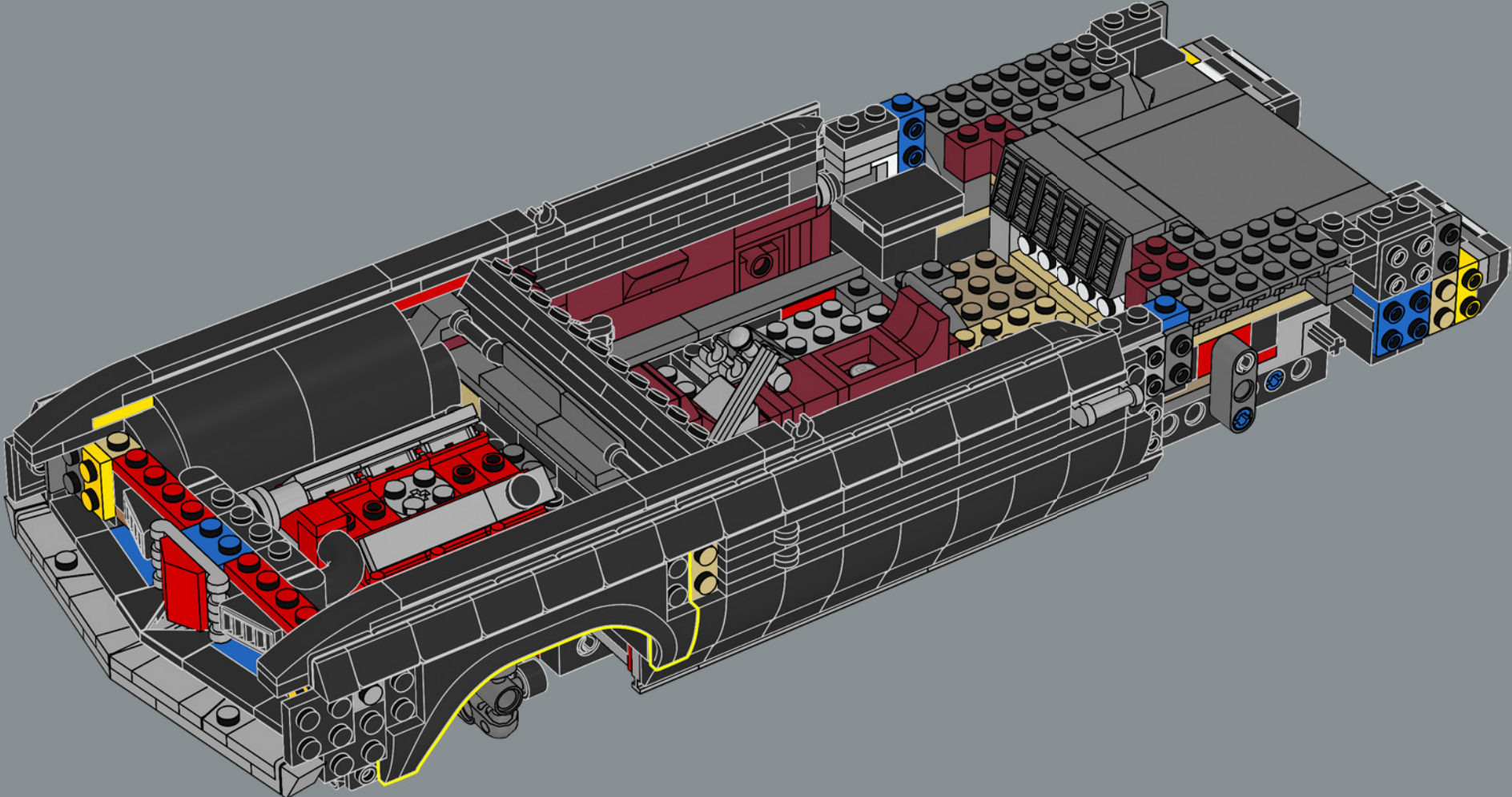

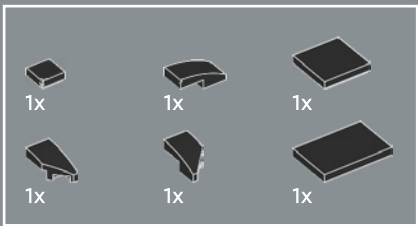

214

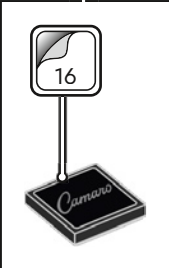
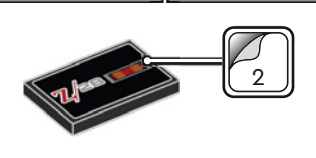
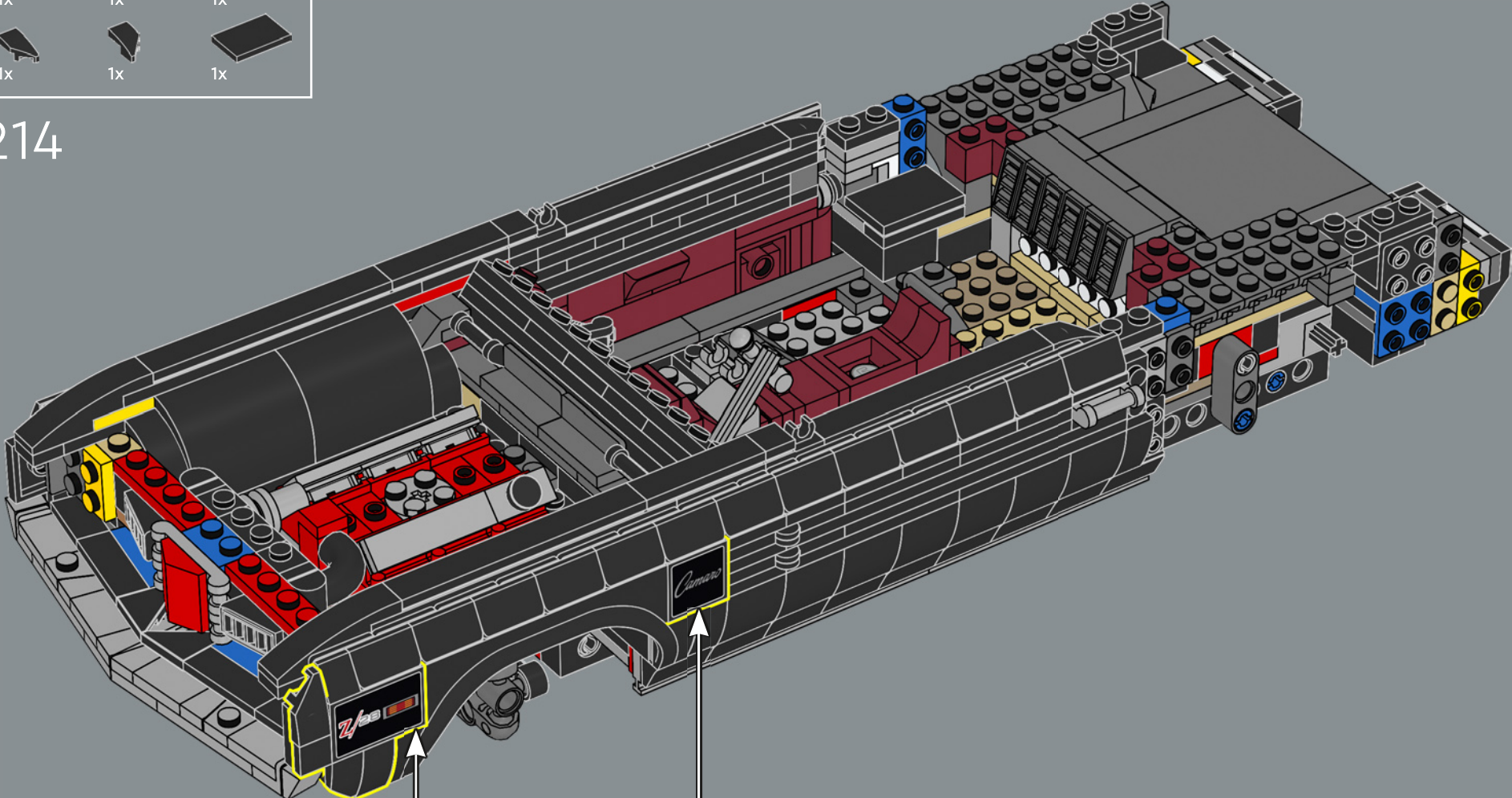

Originariamente, Chevrolet prese in considerazione anche la produzione di una versione station wagon della Camaro.

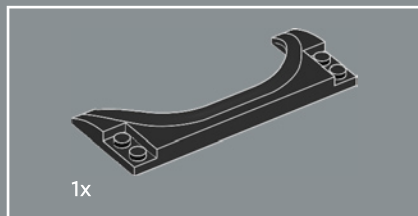

215

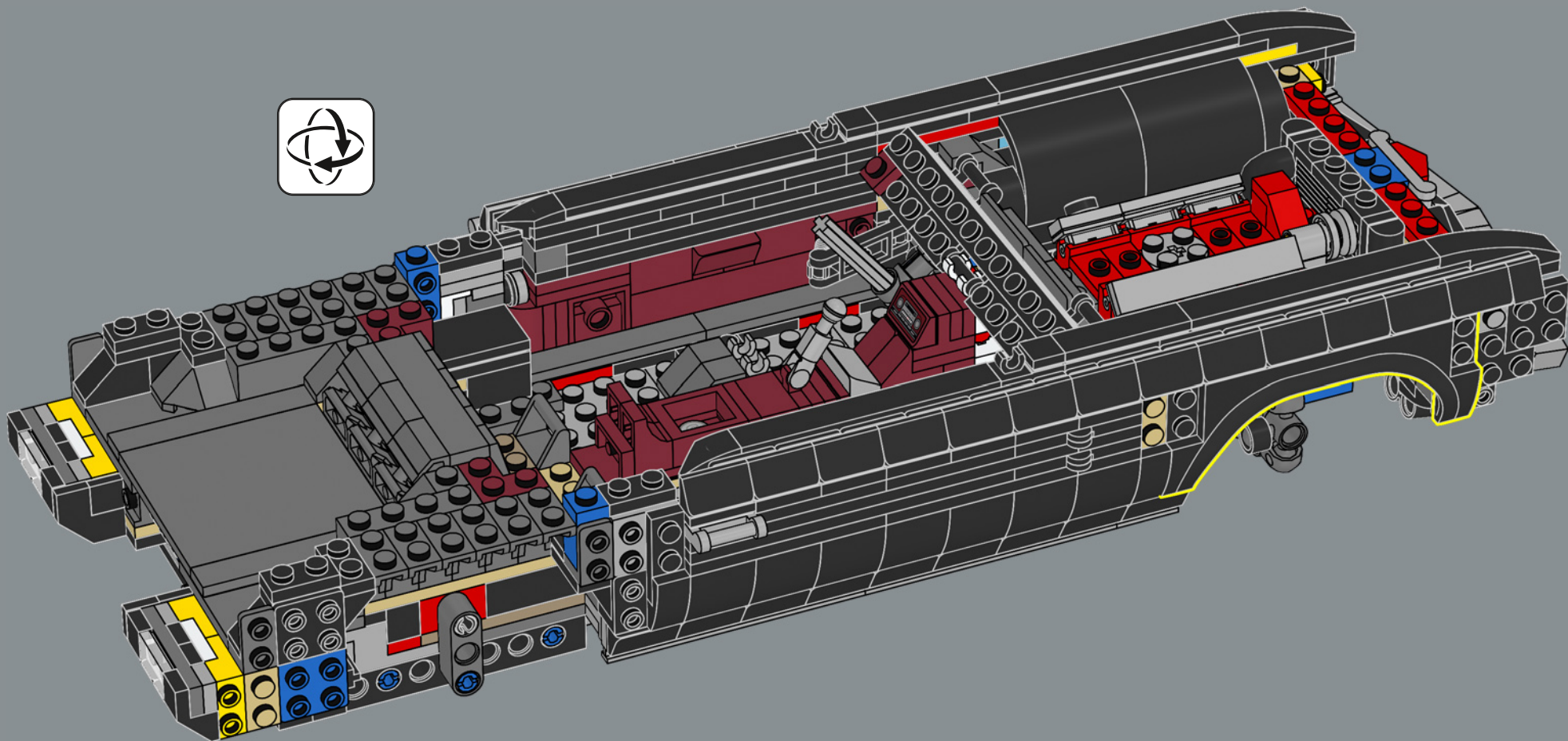

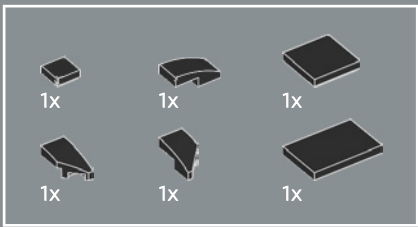

216

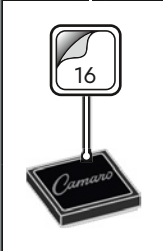
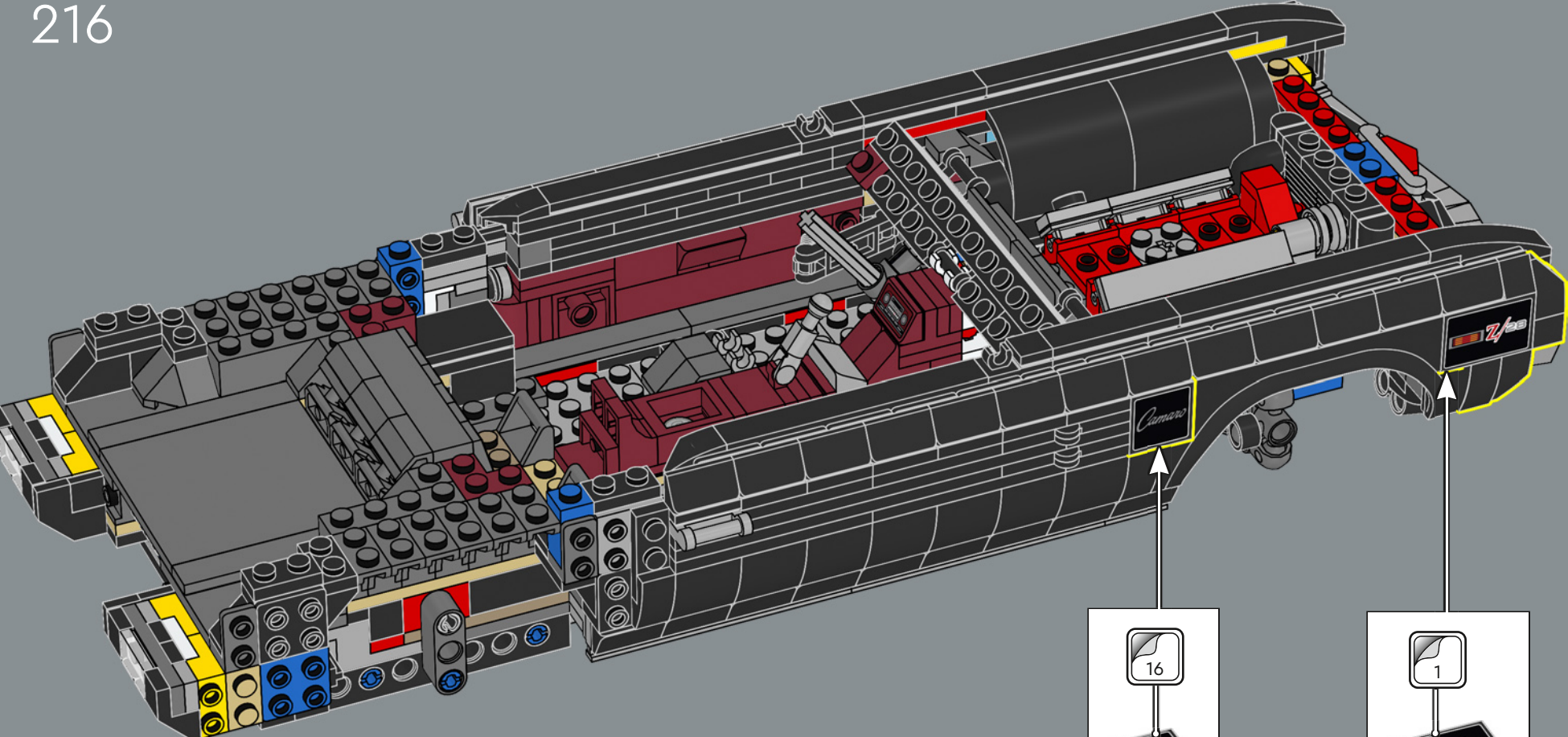

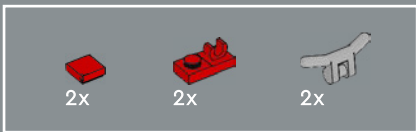

217

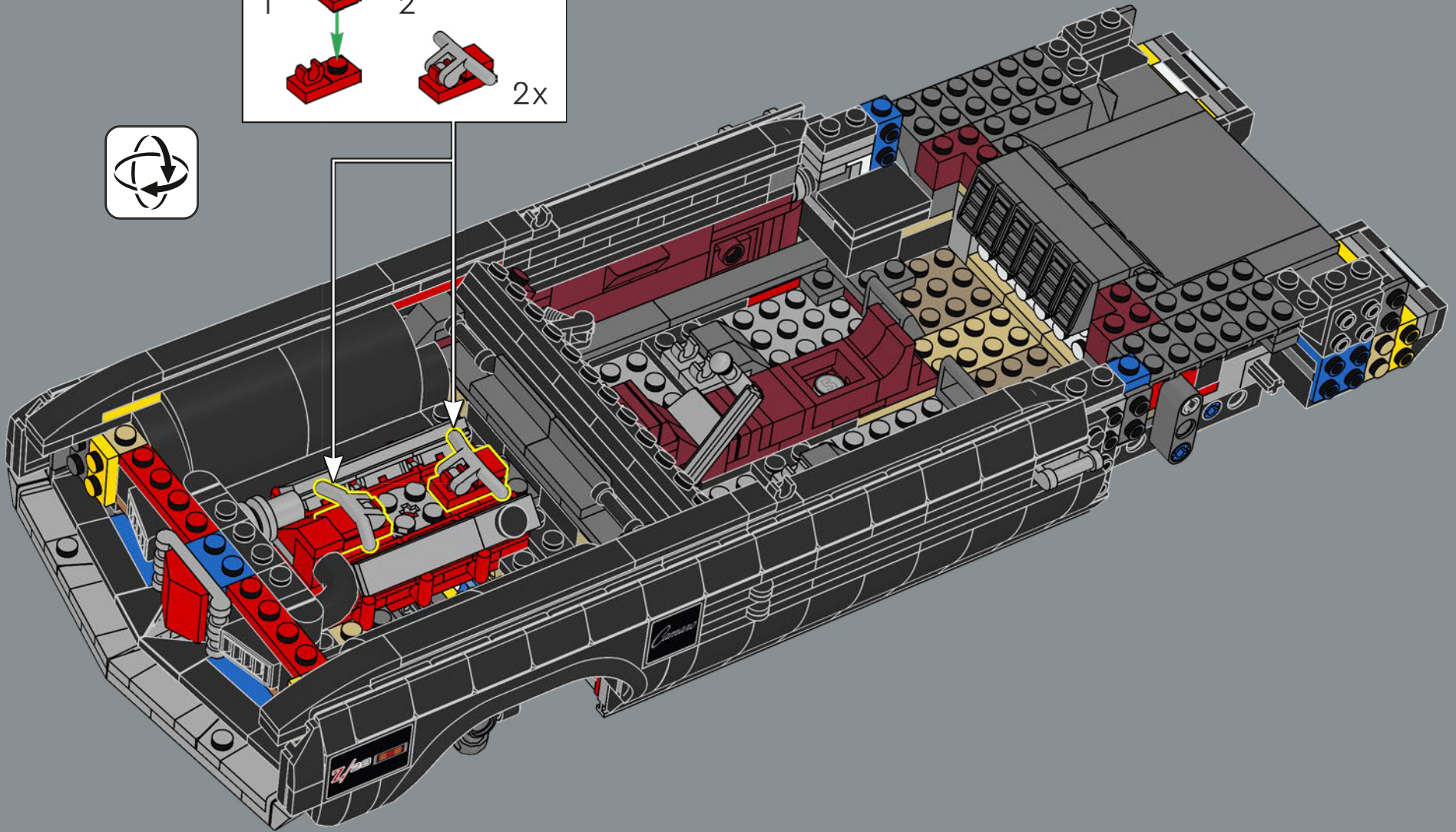
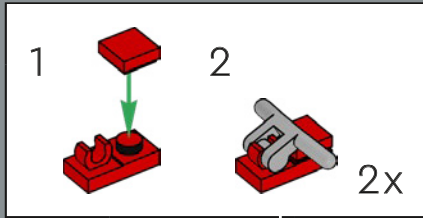

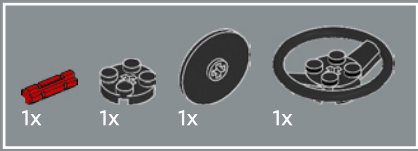

218

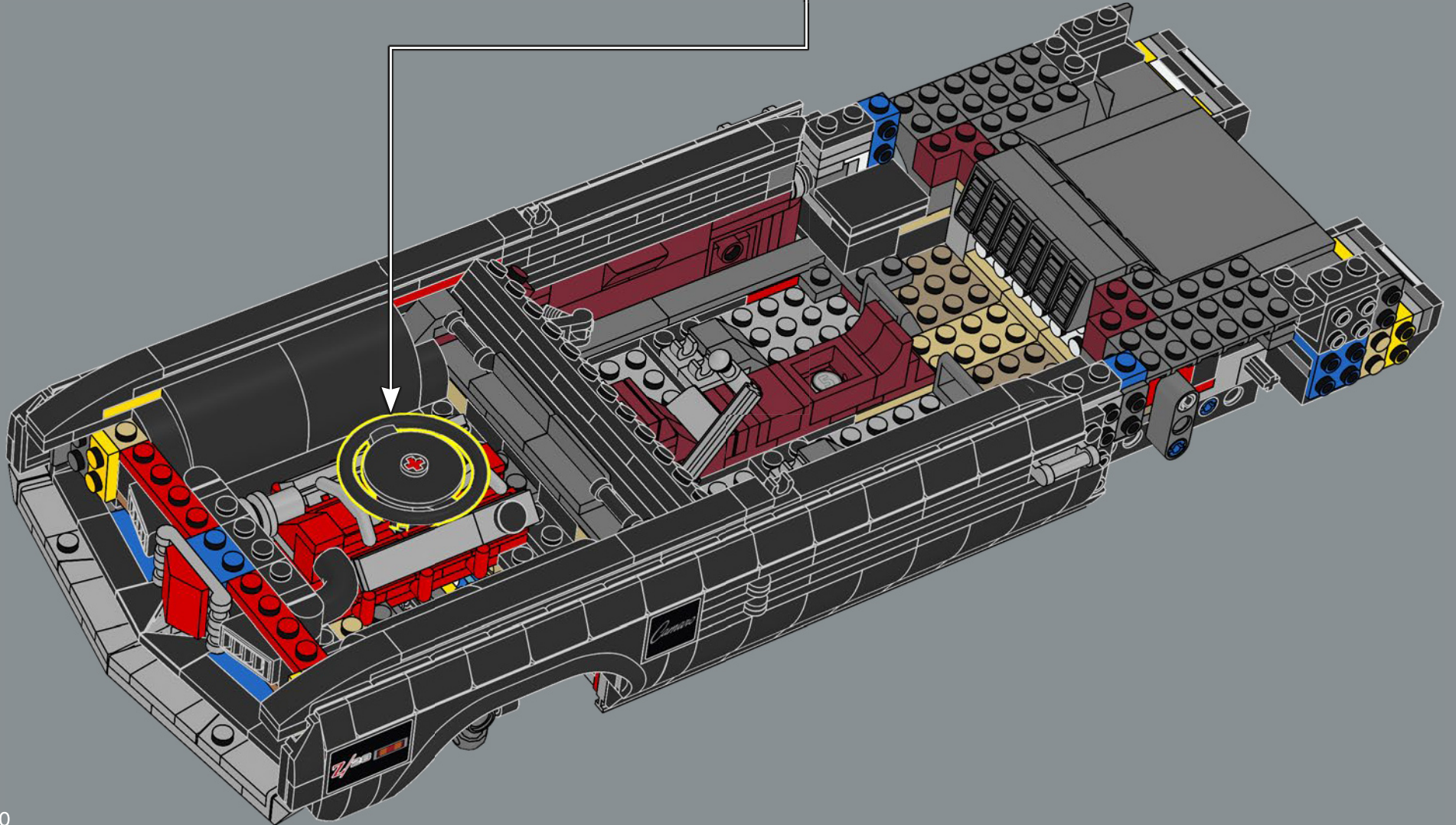
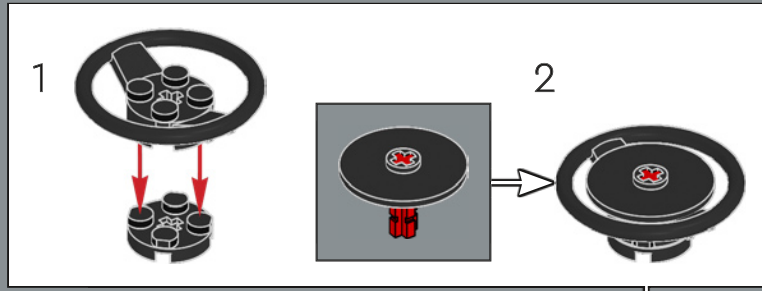

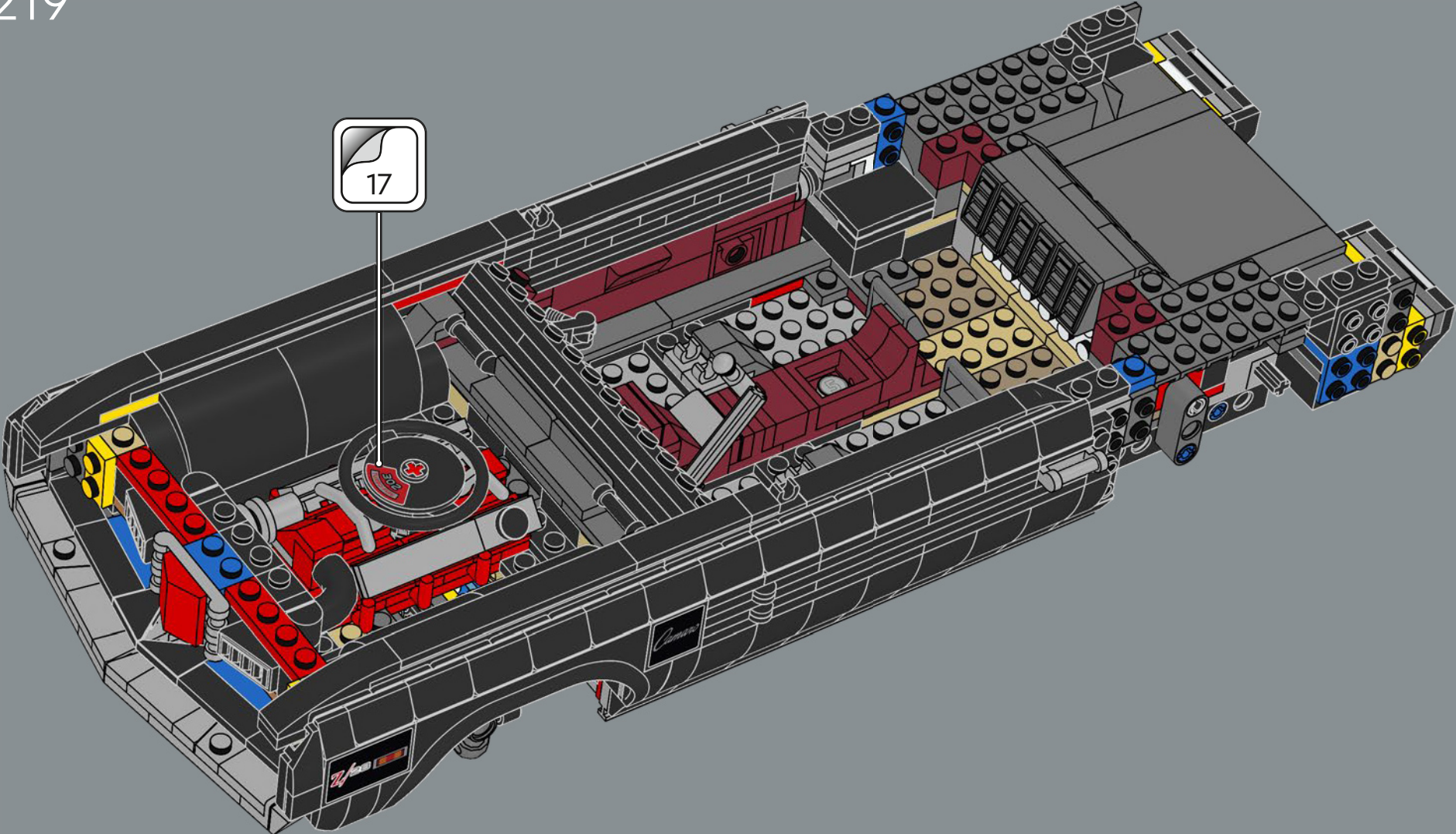

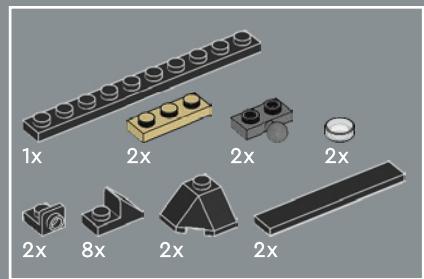

220

1

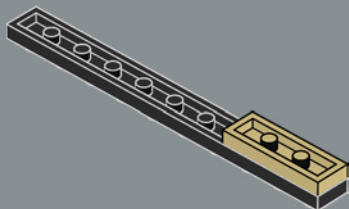

2

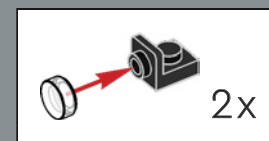
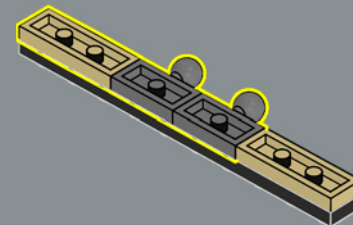

3

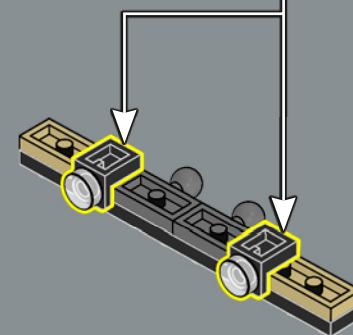

4

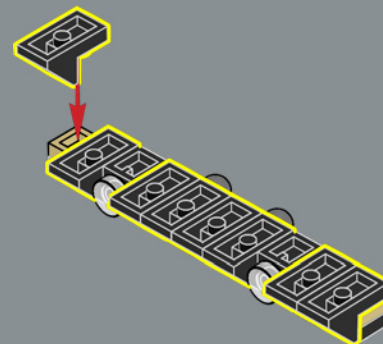

5

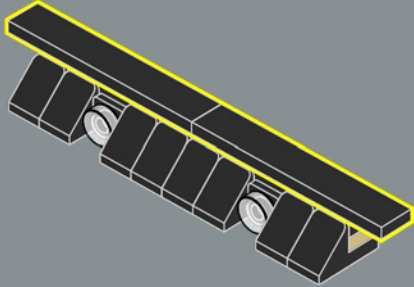

6

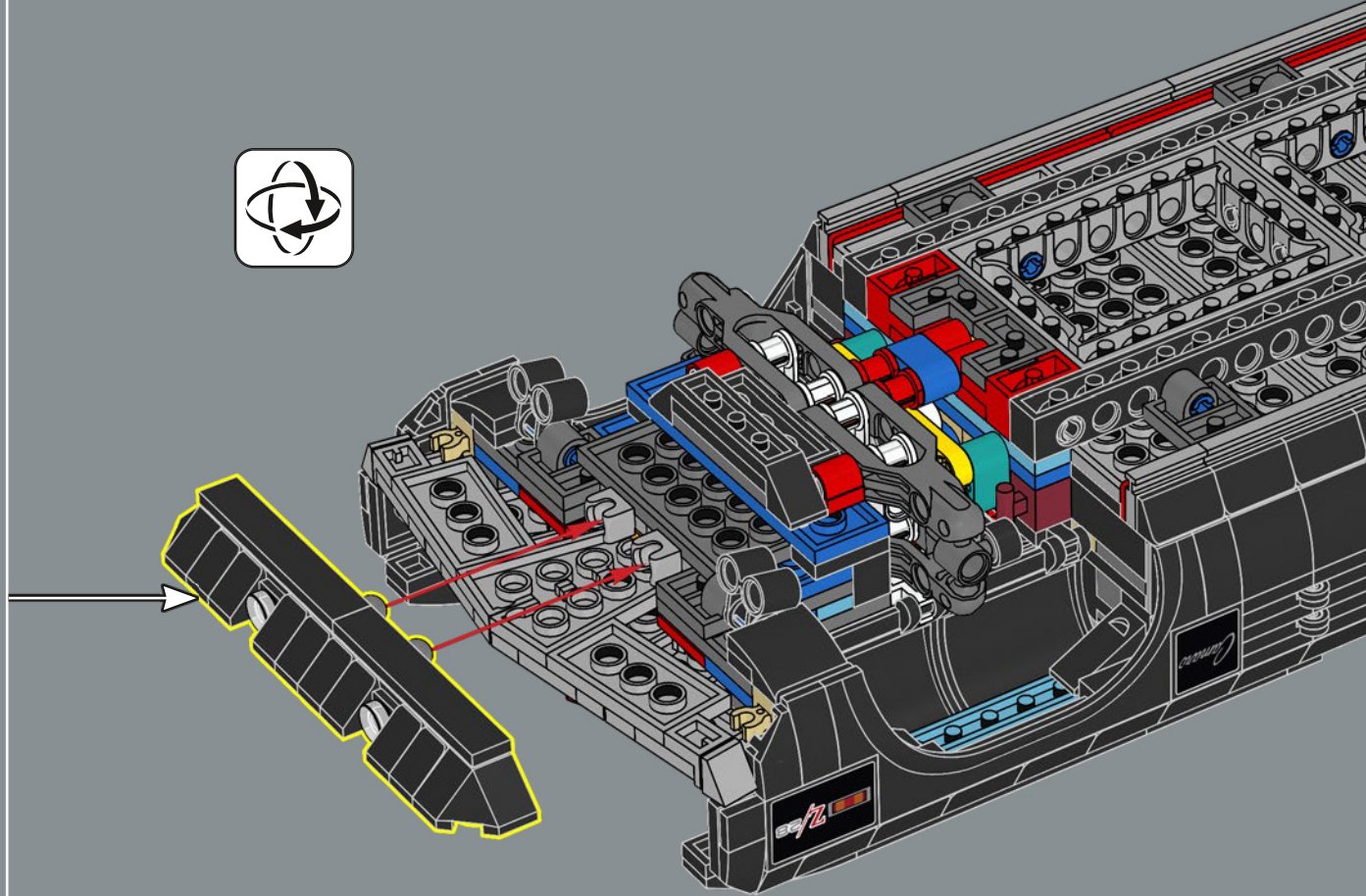
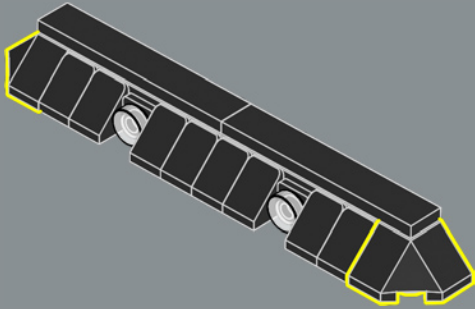

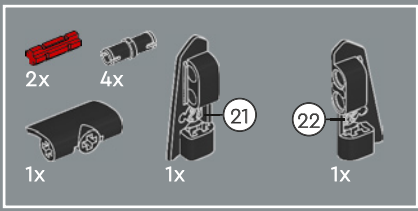

221

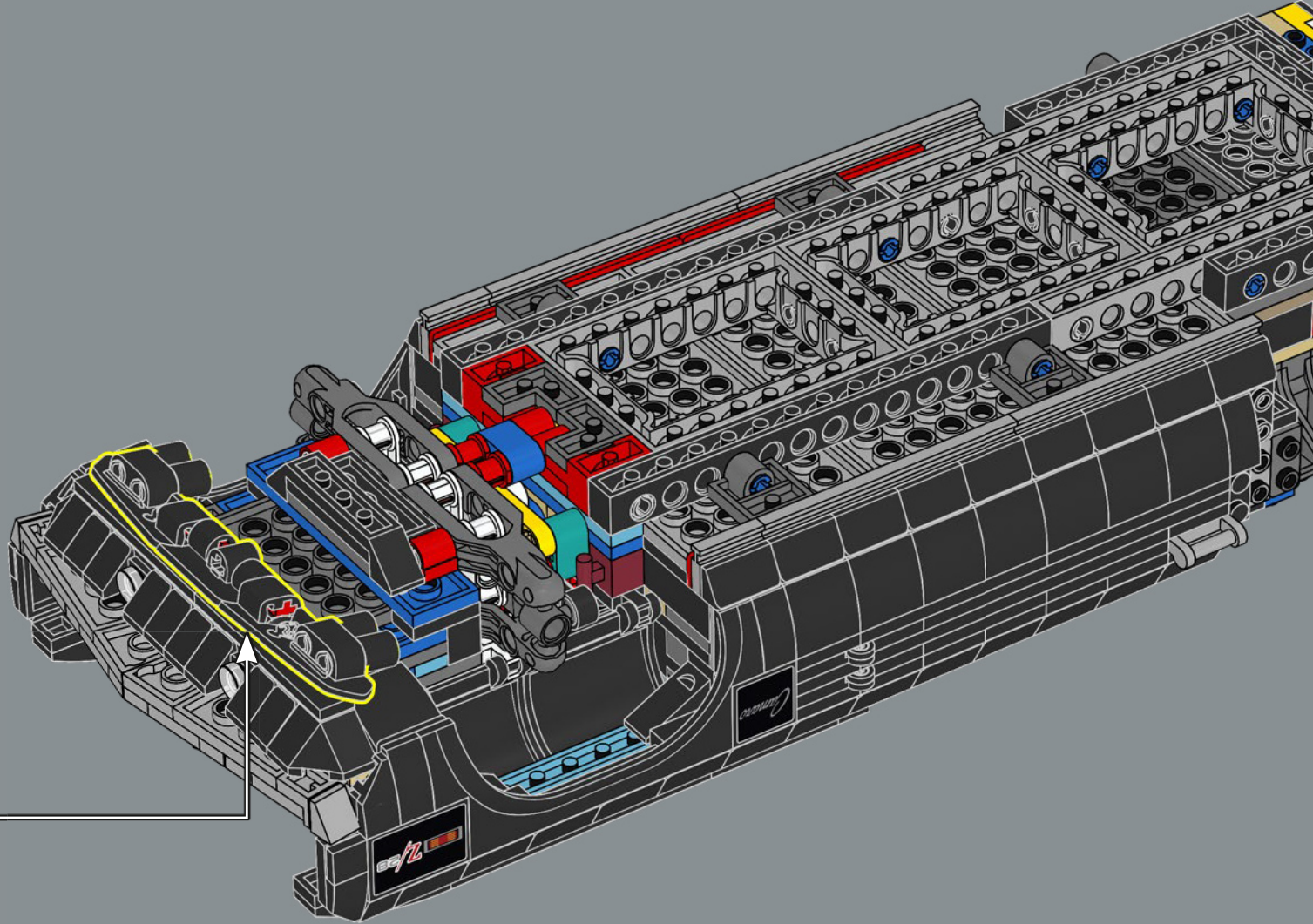
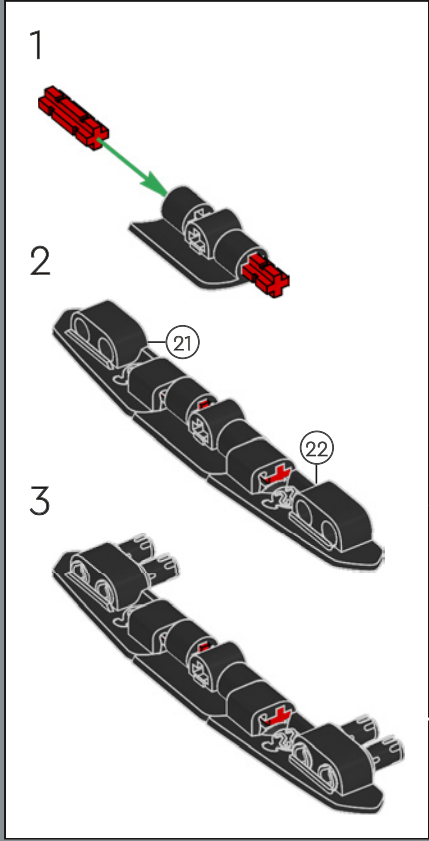



222

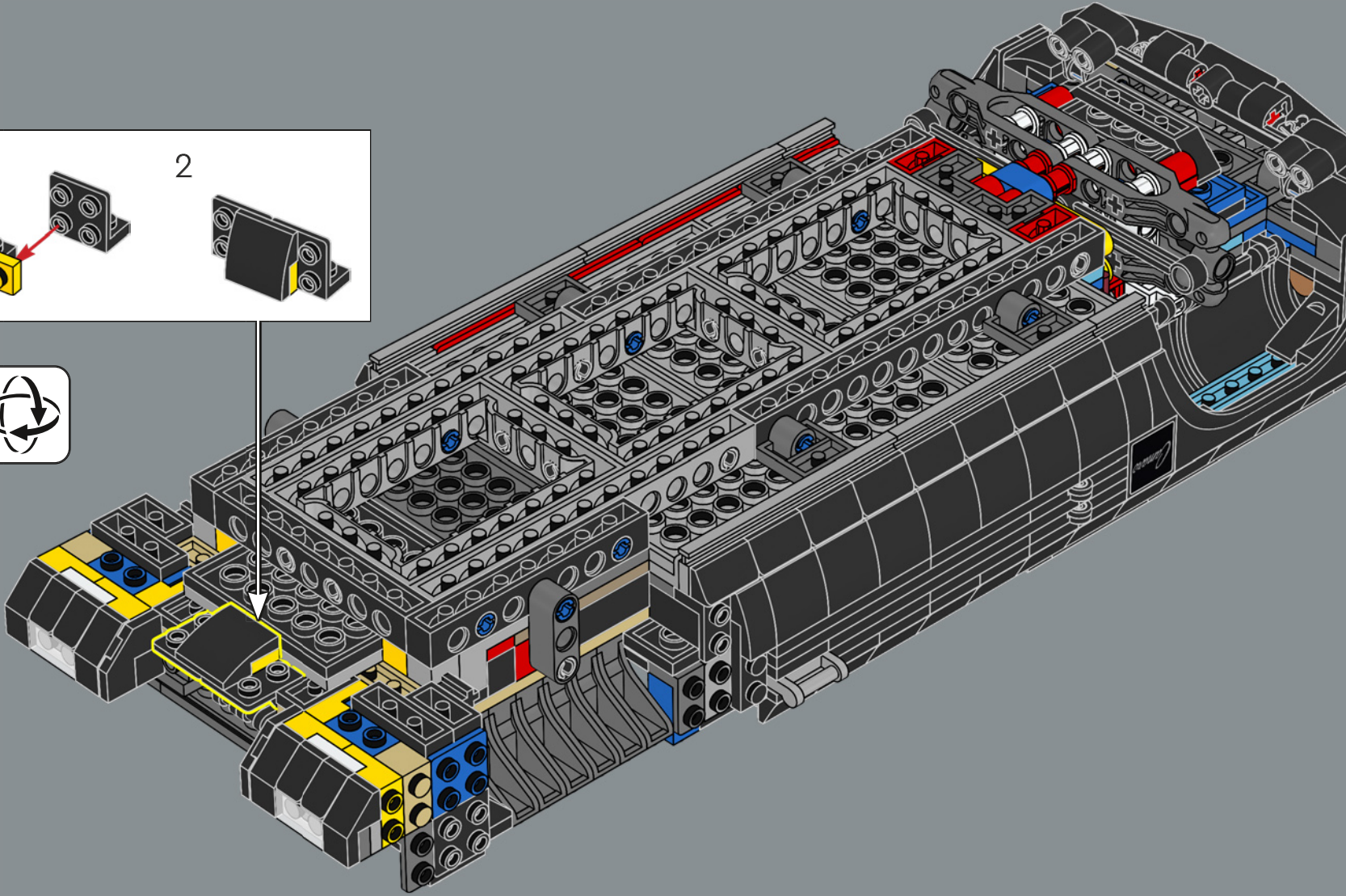
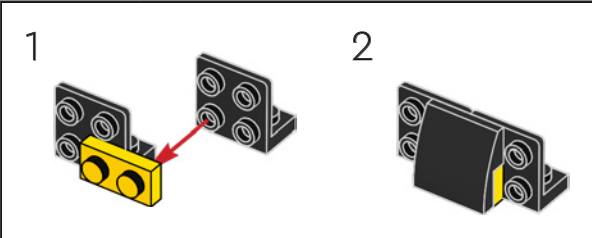

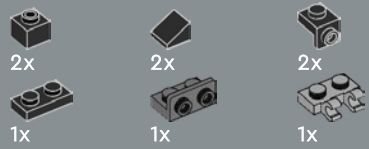

223

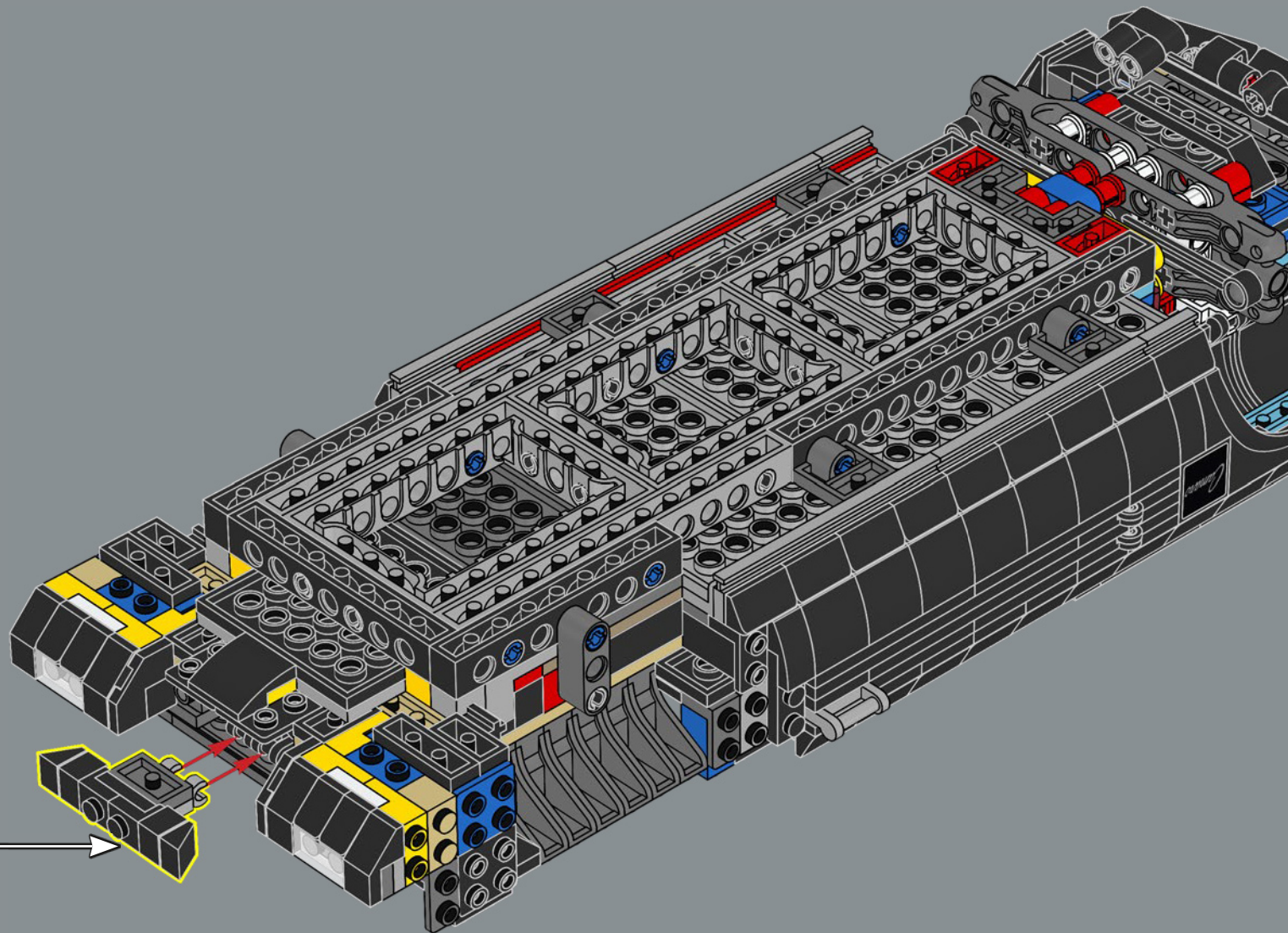
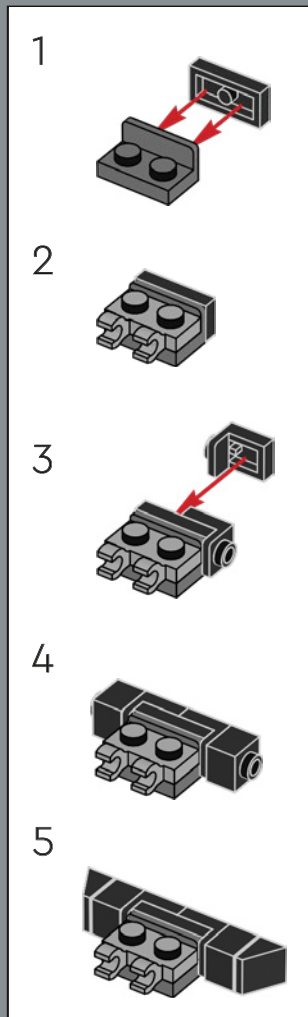

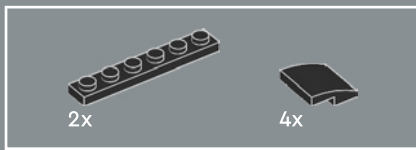

224

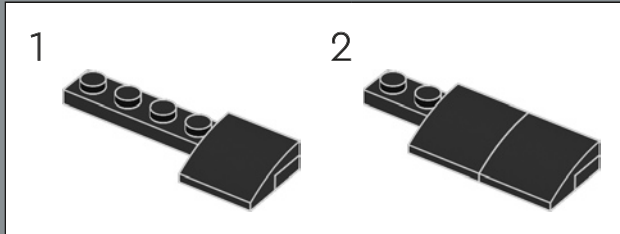

2

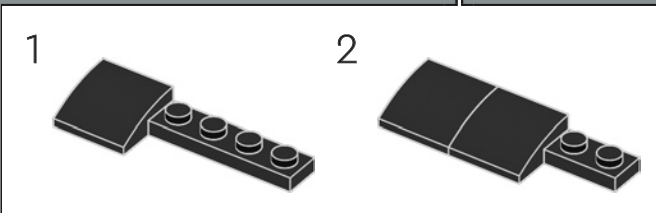
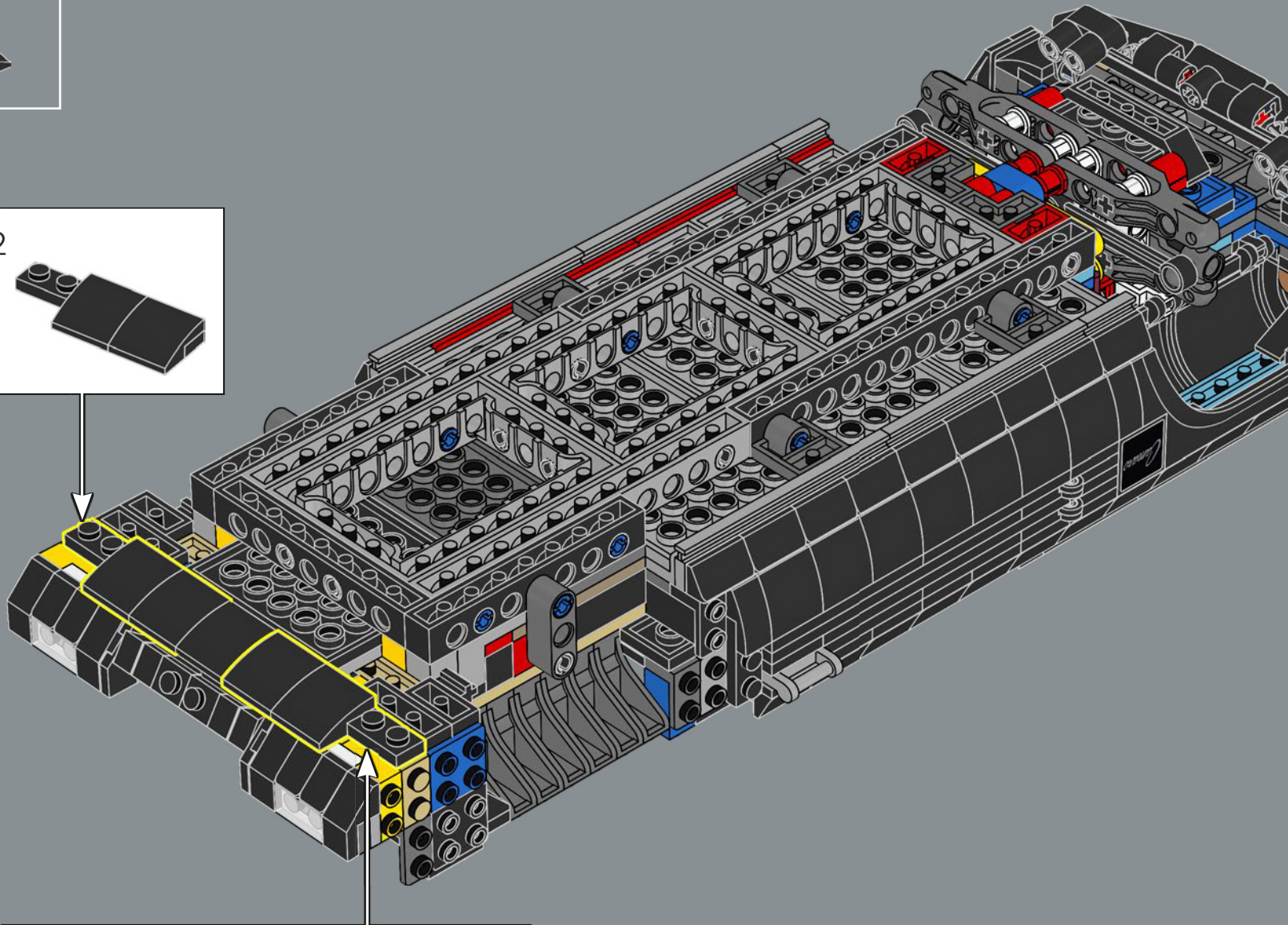
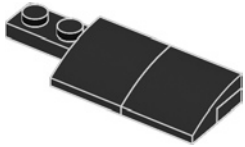

2

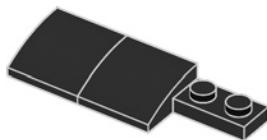



225

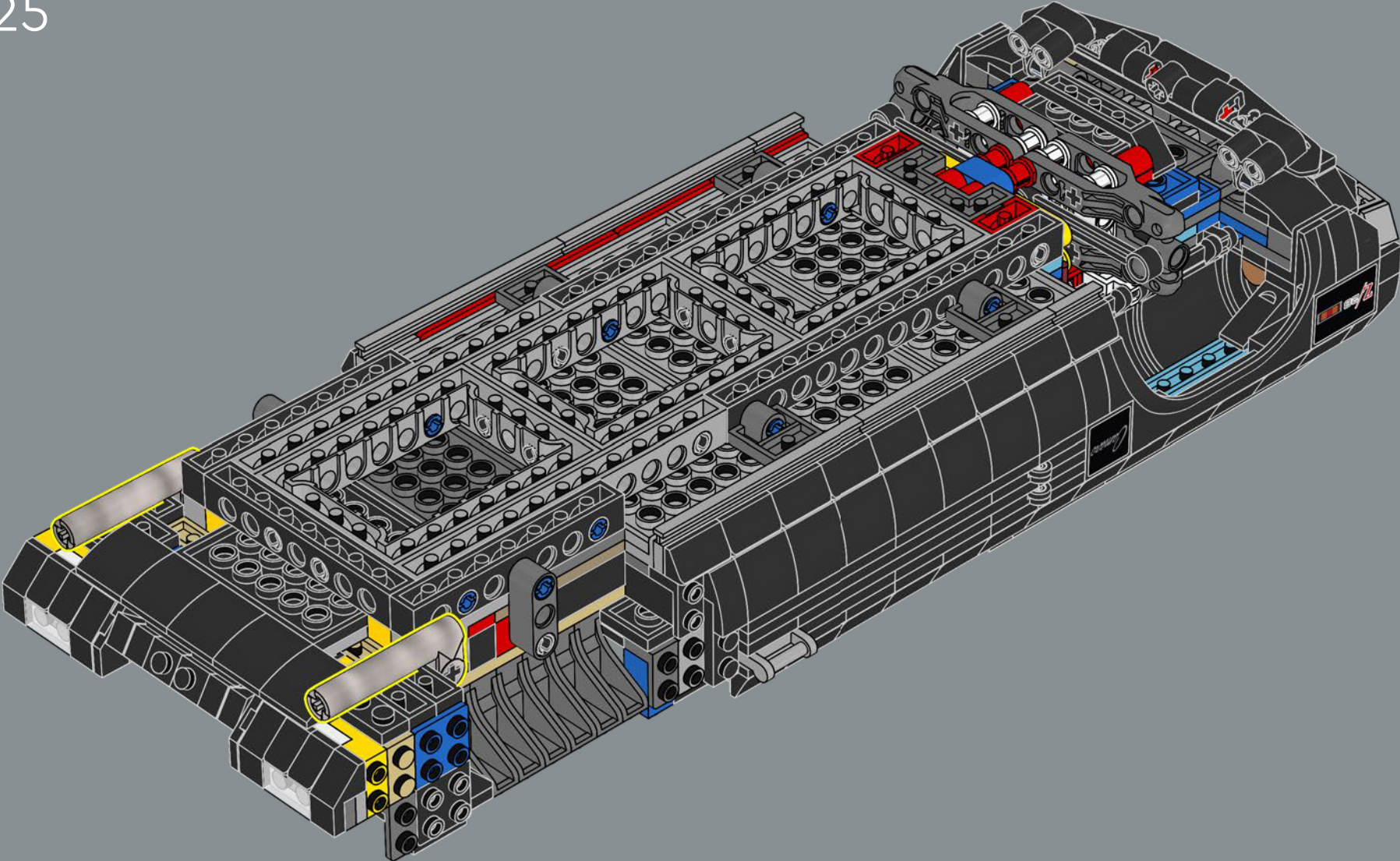

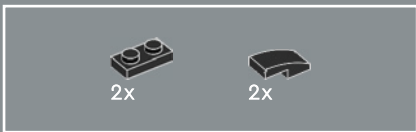

226

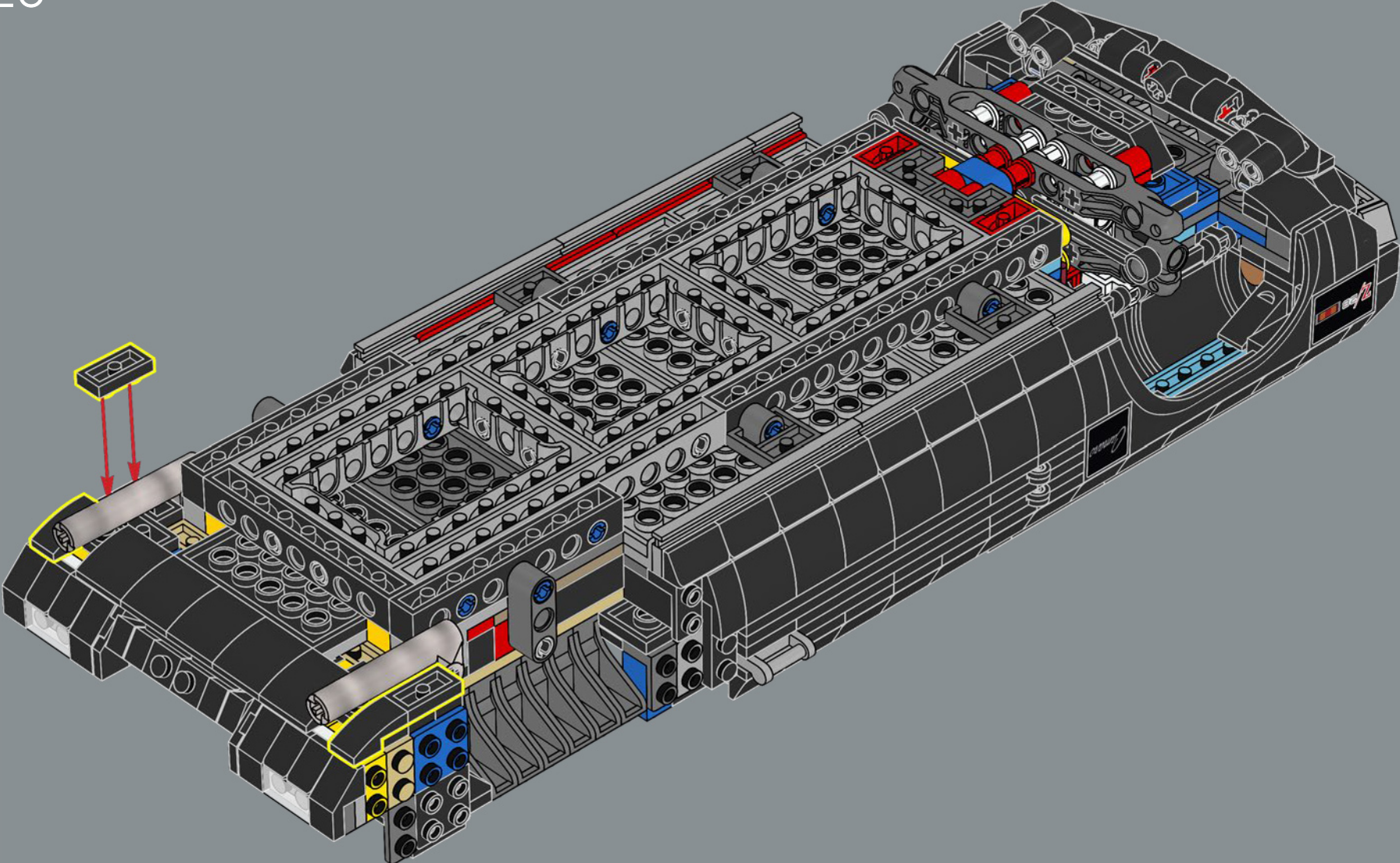

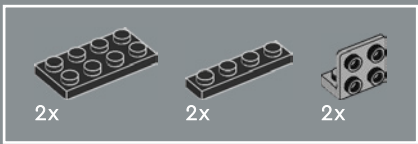

227

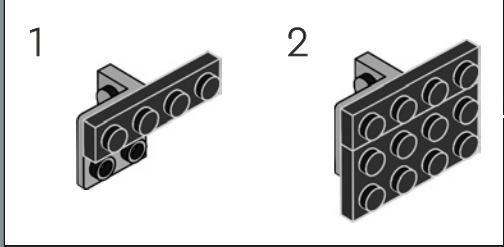
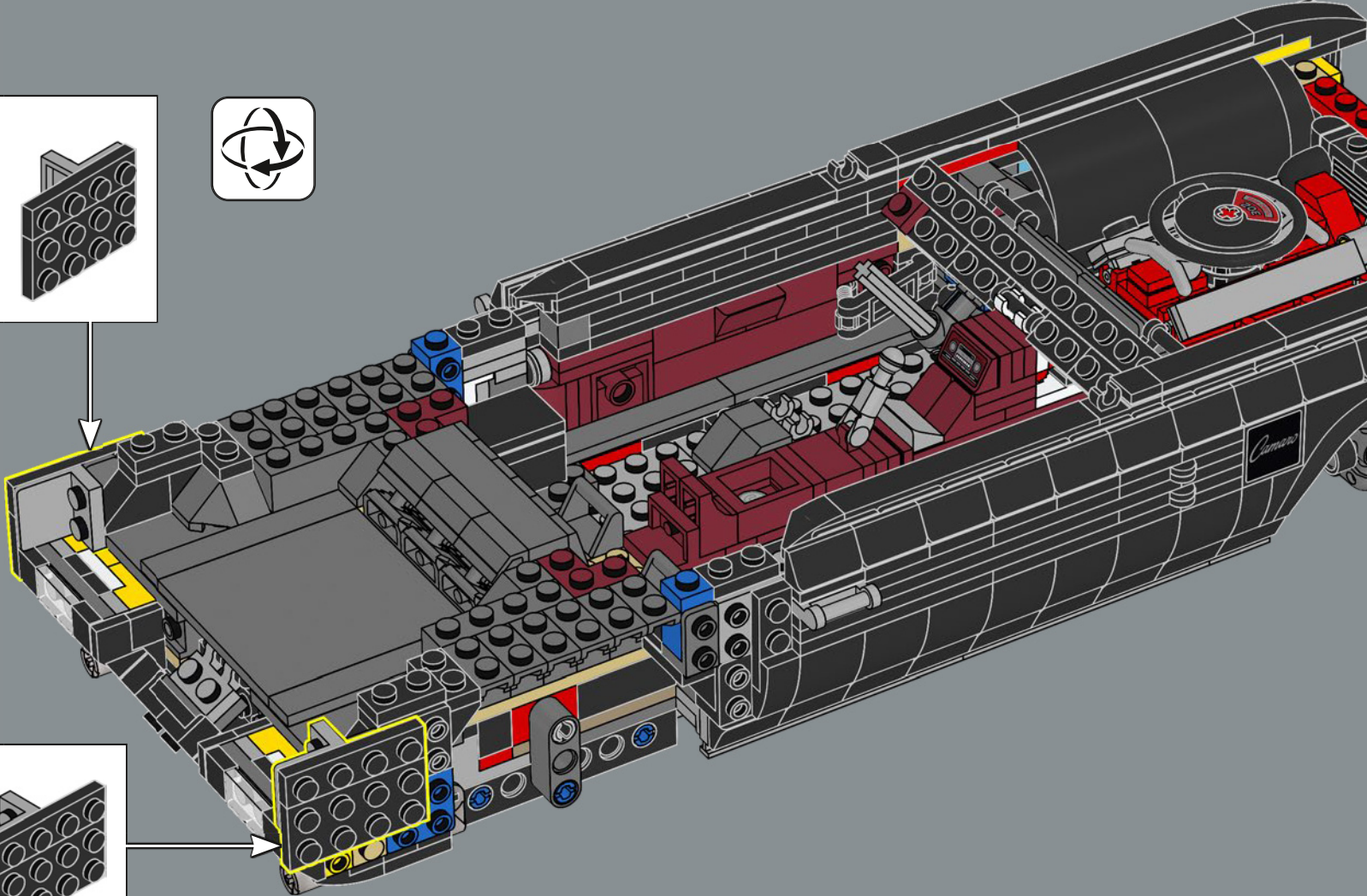
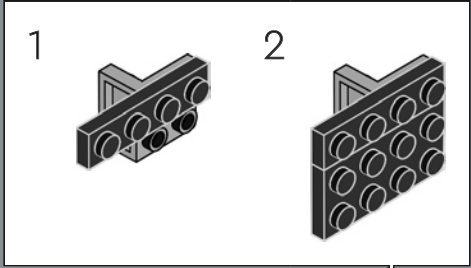

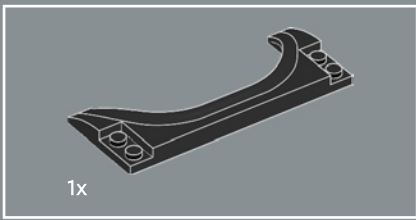

228

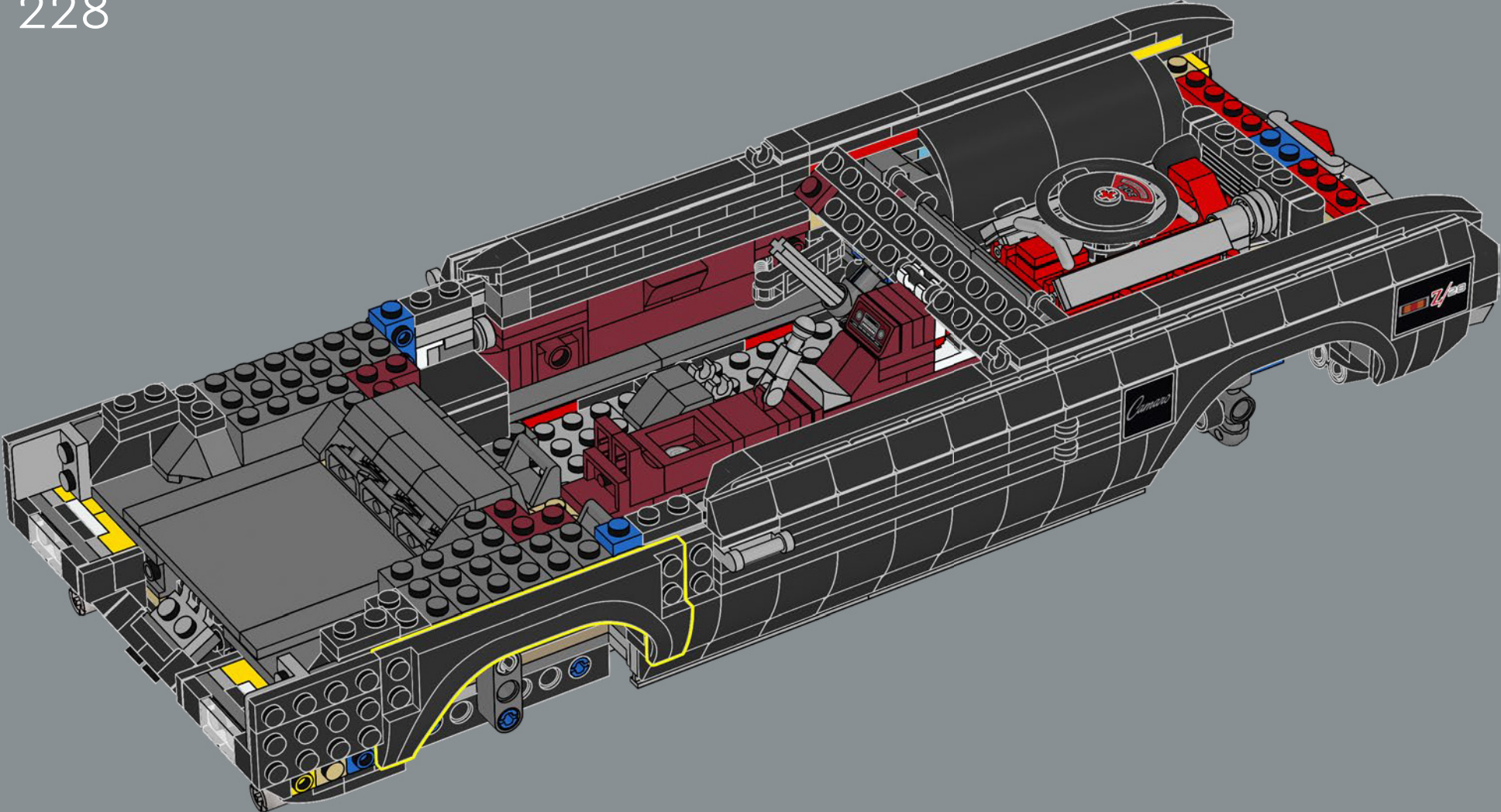

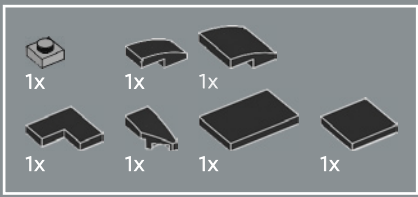

229

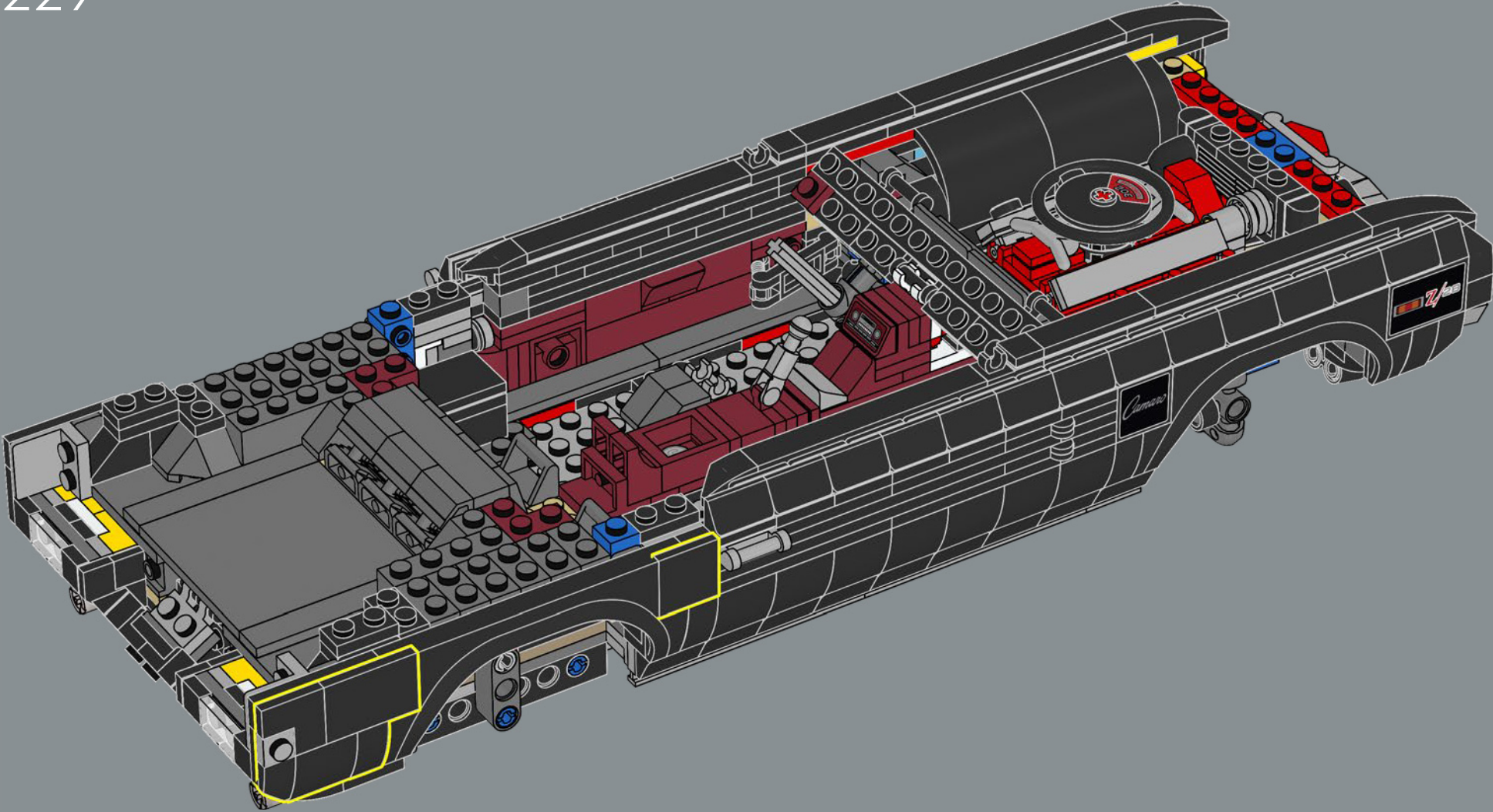

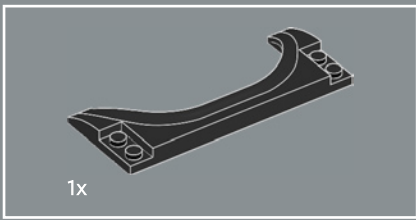

230

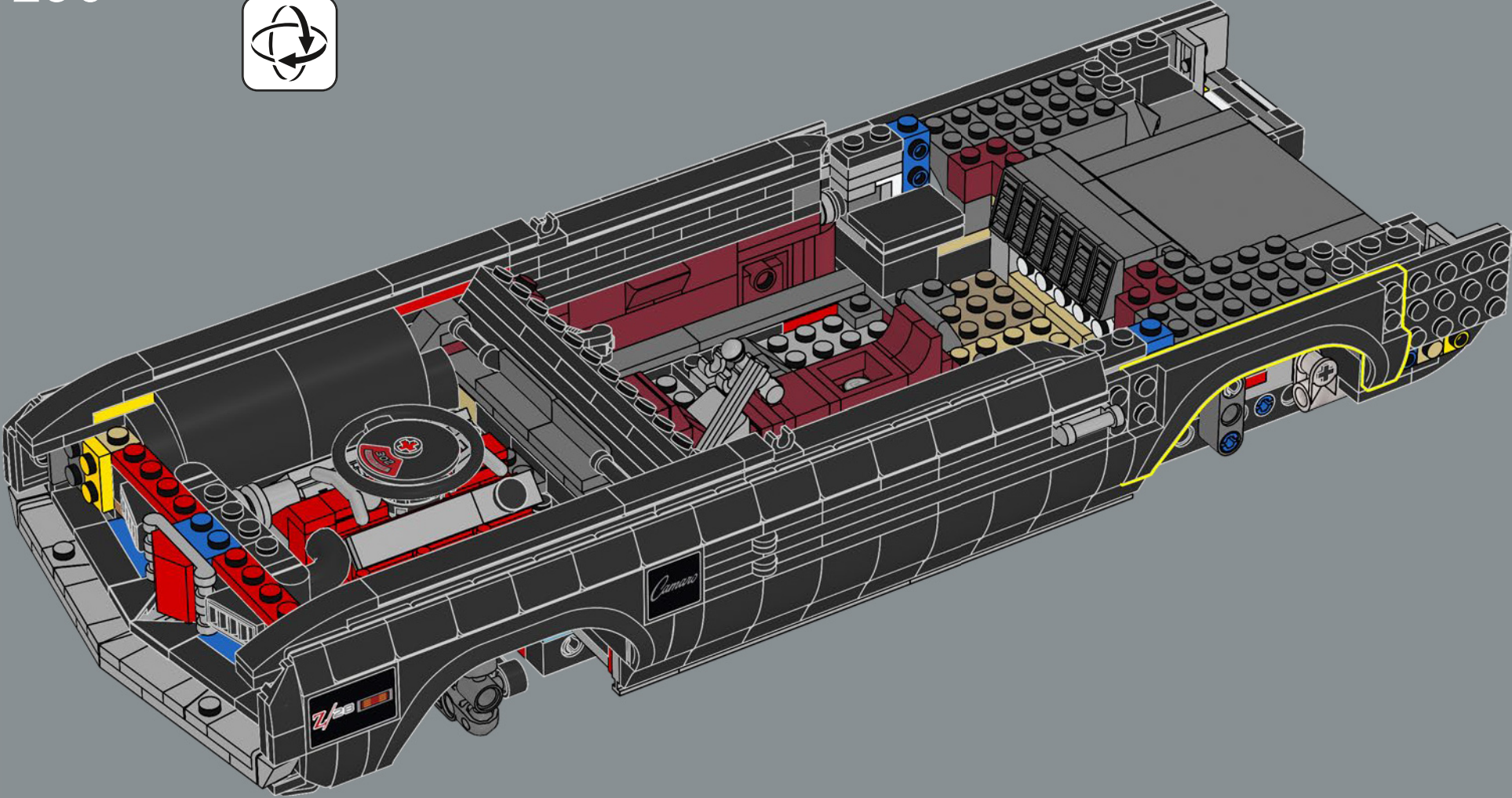

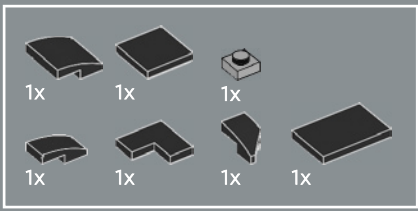

231

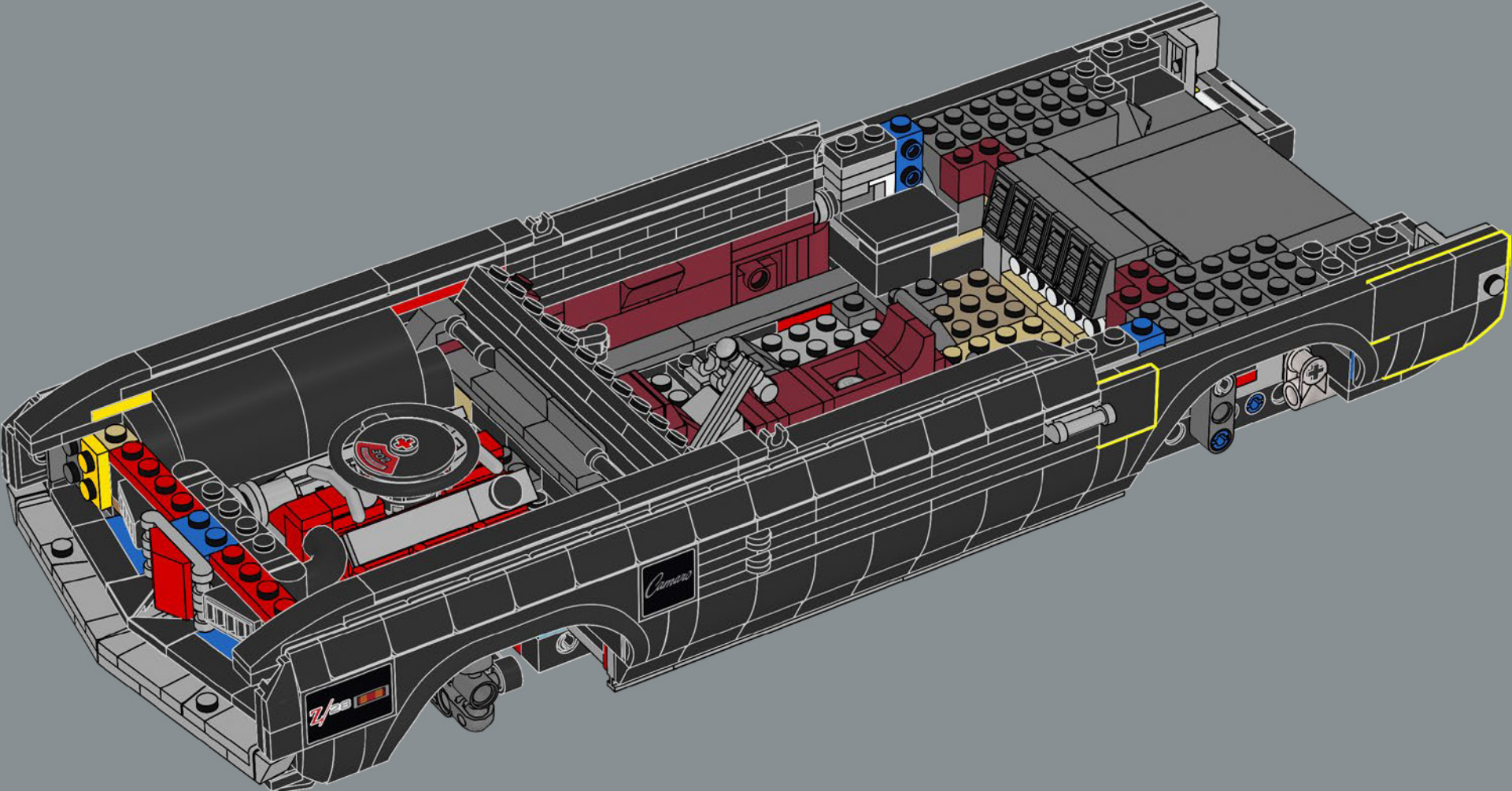

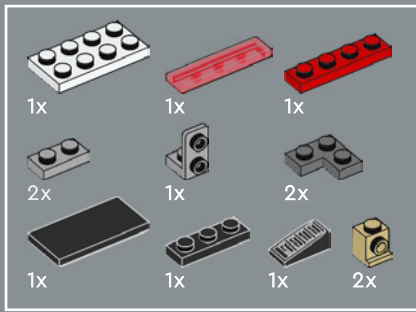

232

1



2



3

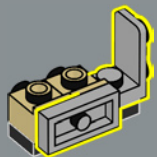

4

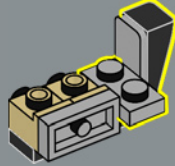

5

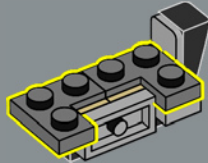

6

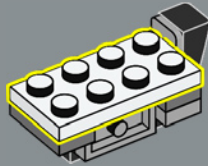

7

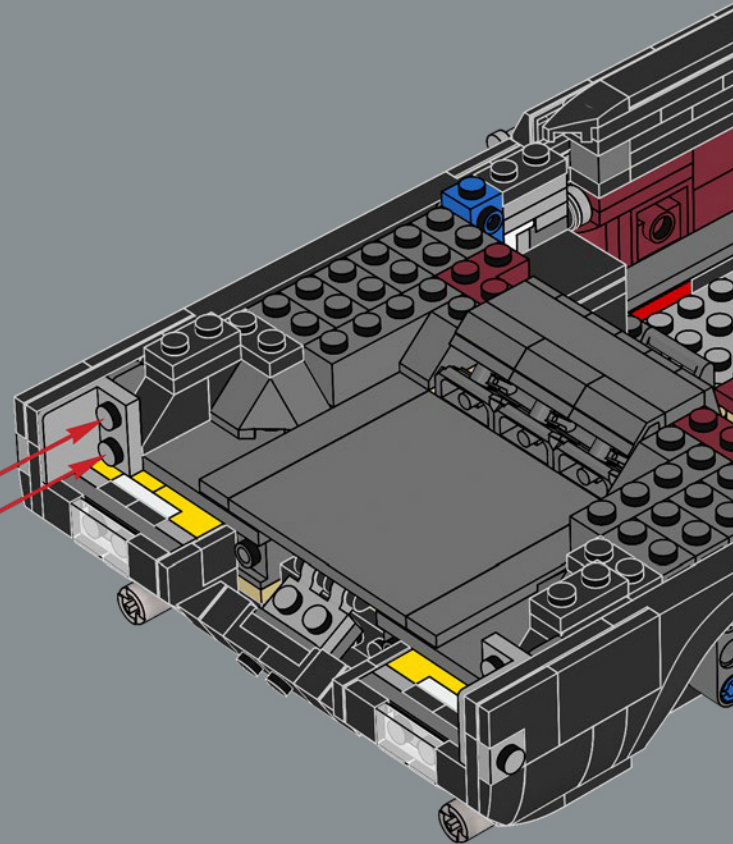
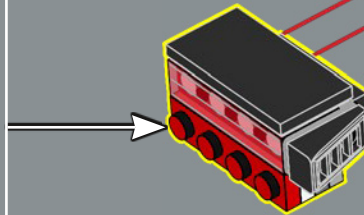
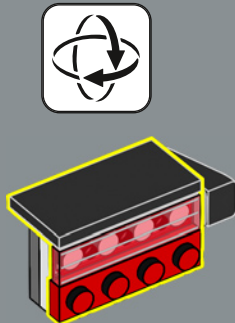

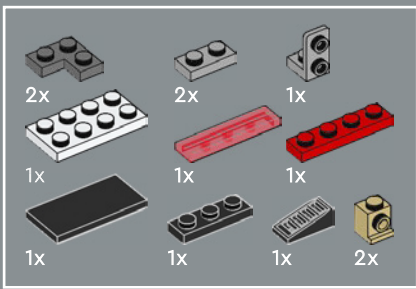

233

1



2

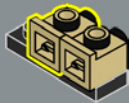

3

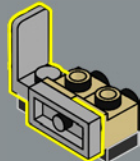

4

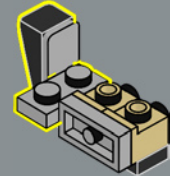

5

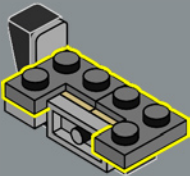

6

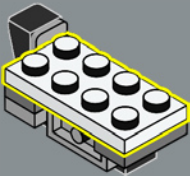

7

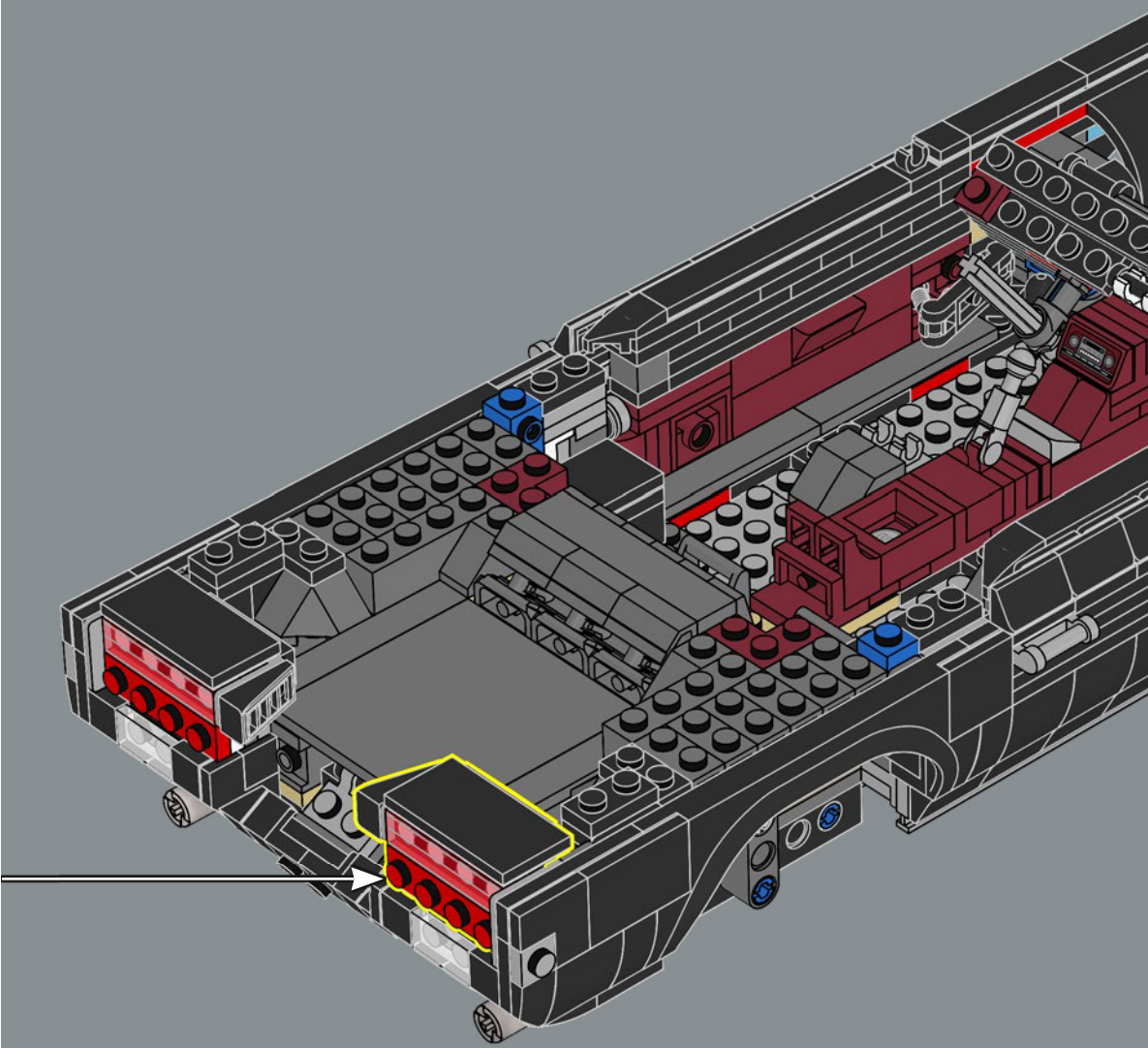
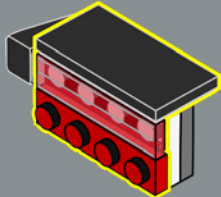

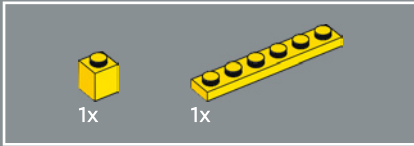
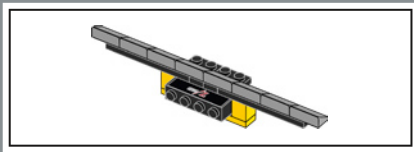

234

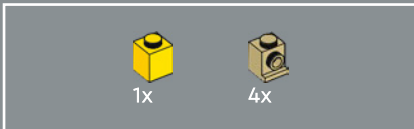
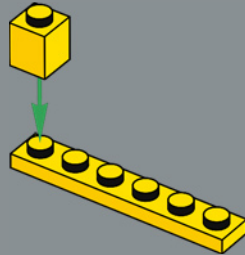

235

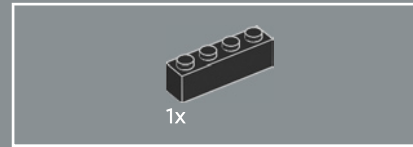
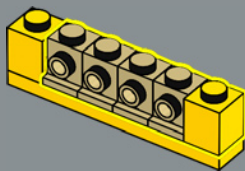

236

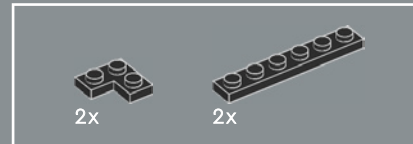
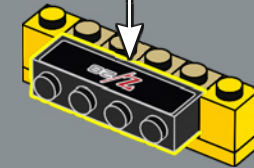
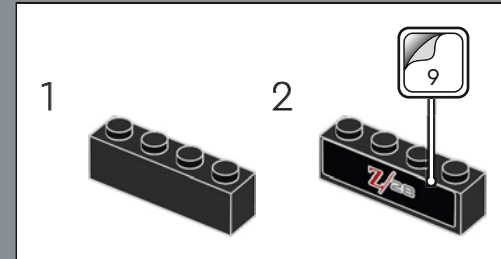

237

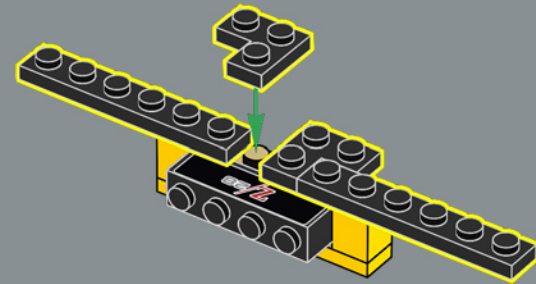



2x

238

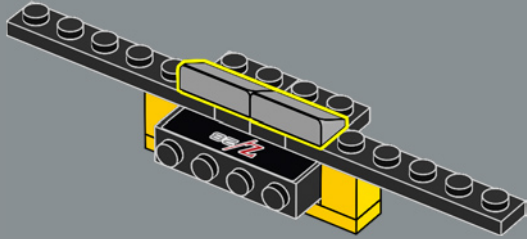

6x

239

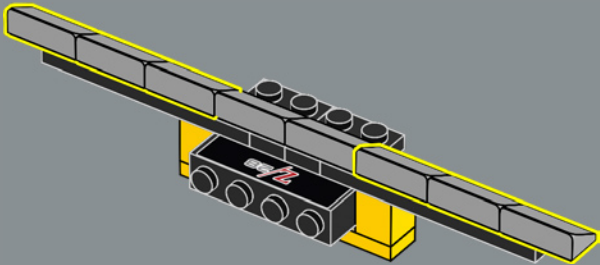

240

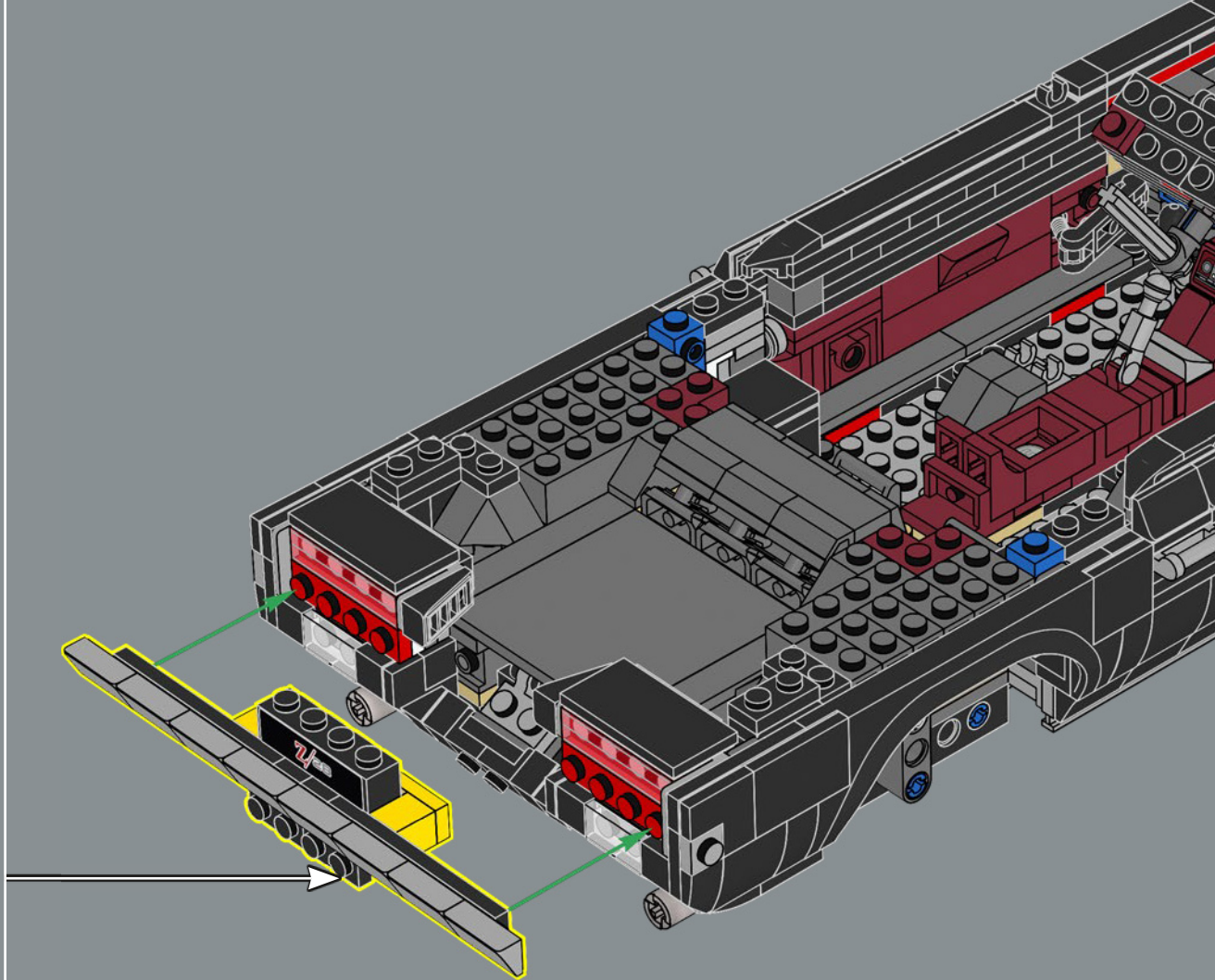

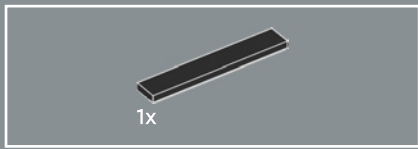

241

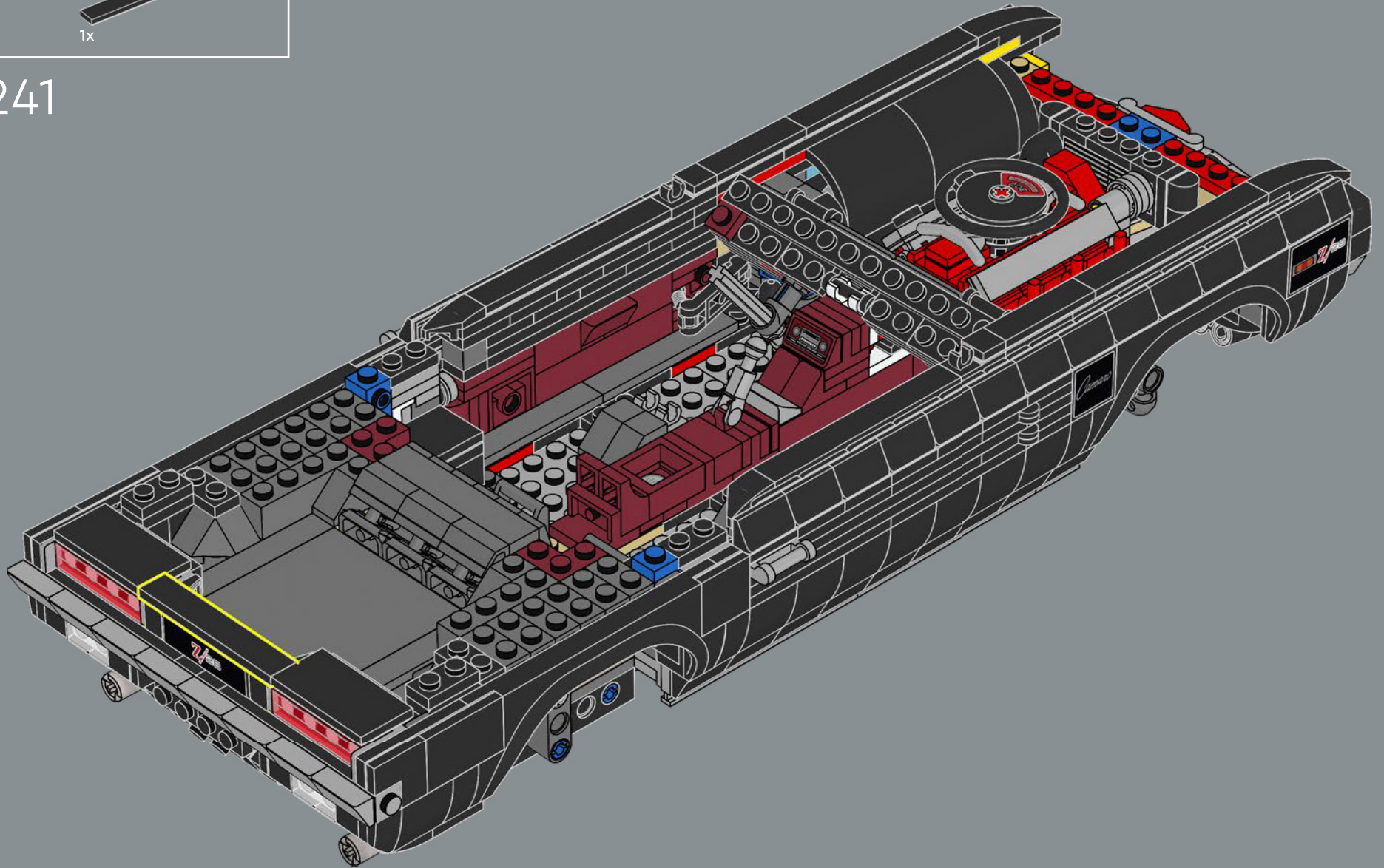

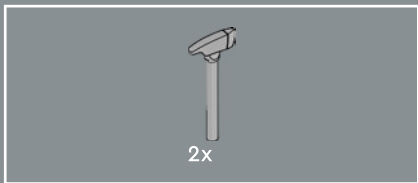

242

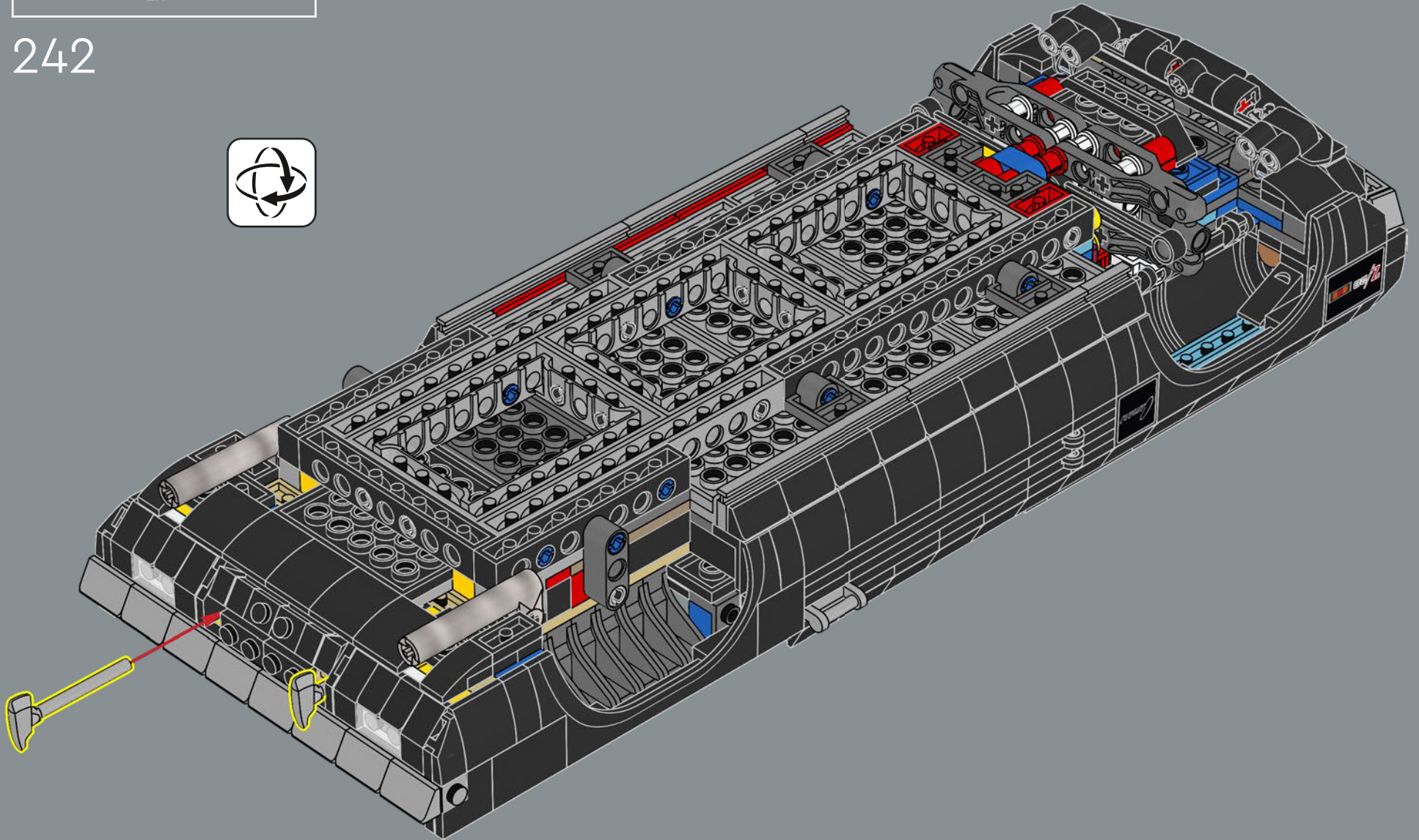

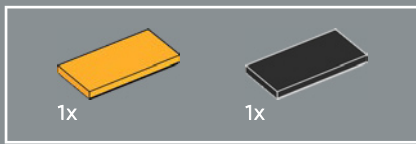

A differenza della maggior parte delle Chevrolet, le prime 3 Camaro di prima generazione non furono costruite a Detroit, ma furono prodotte negli stabilimenti di Norwood, Ohio e Van Nuys, California.

243

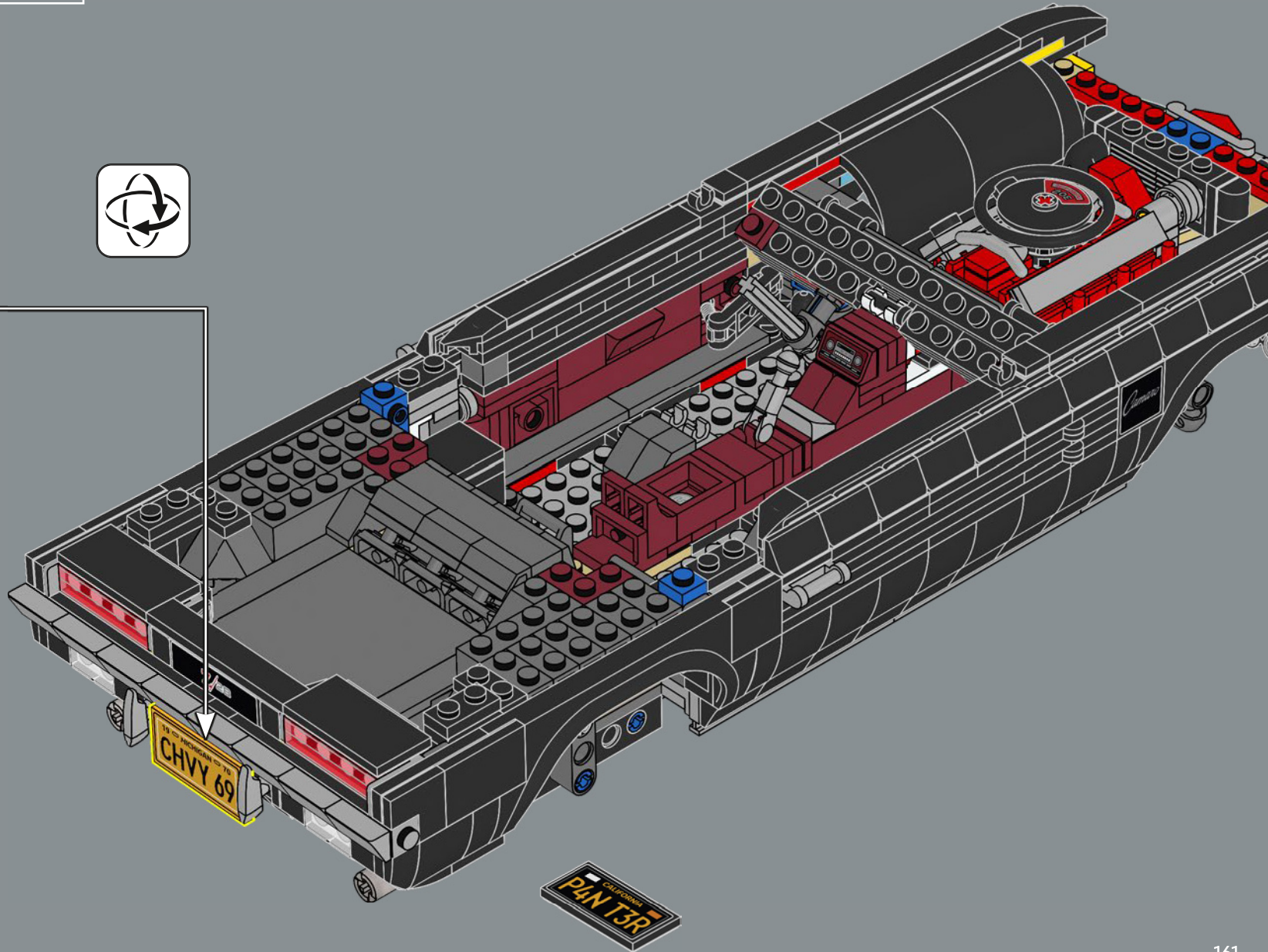
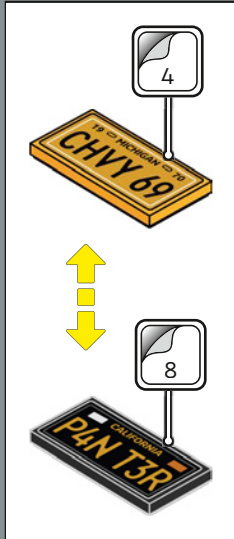

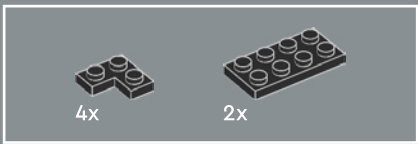

244

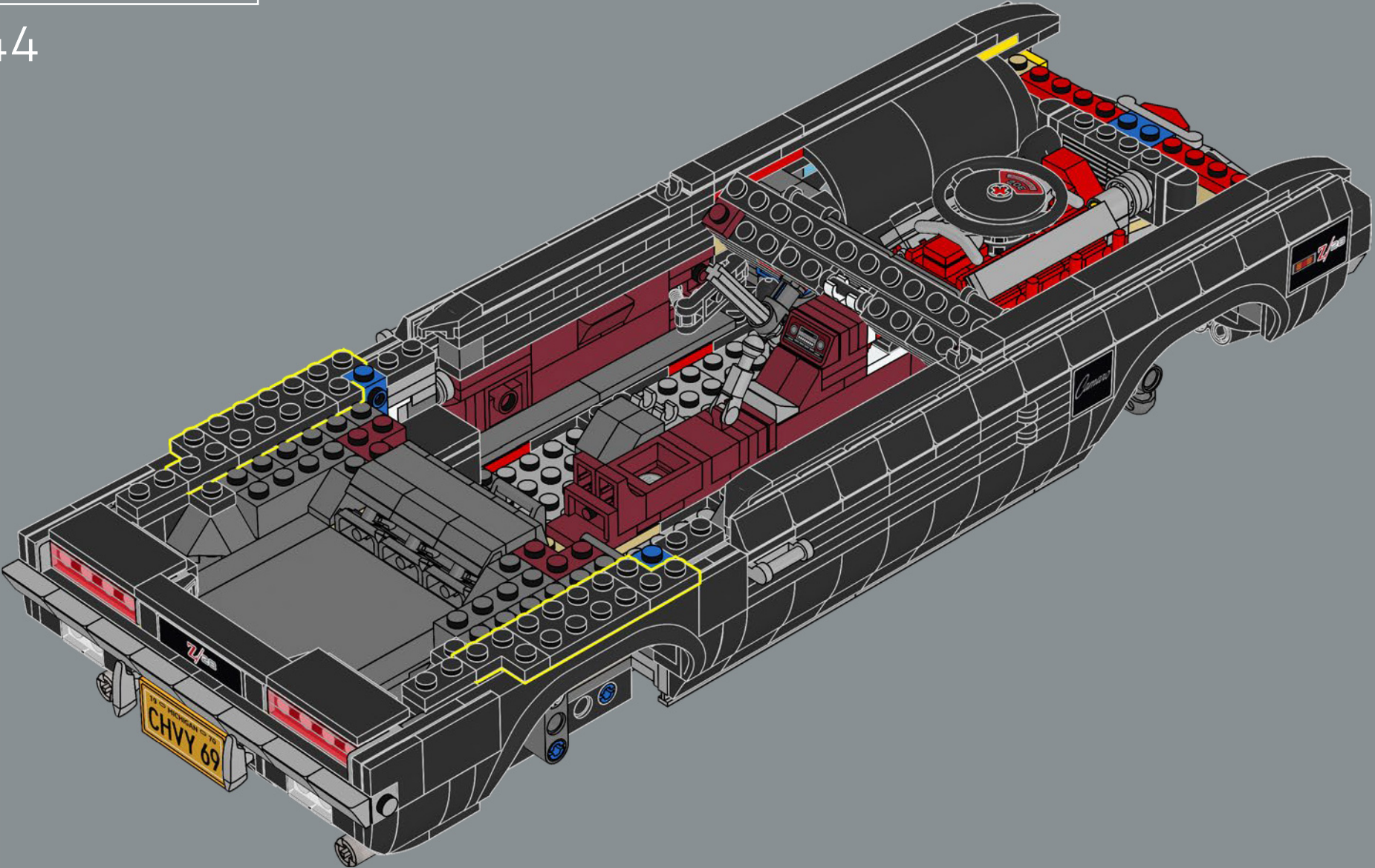

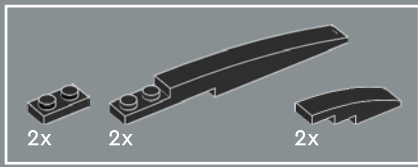

245

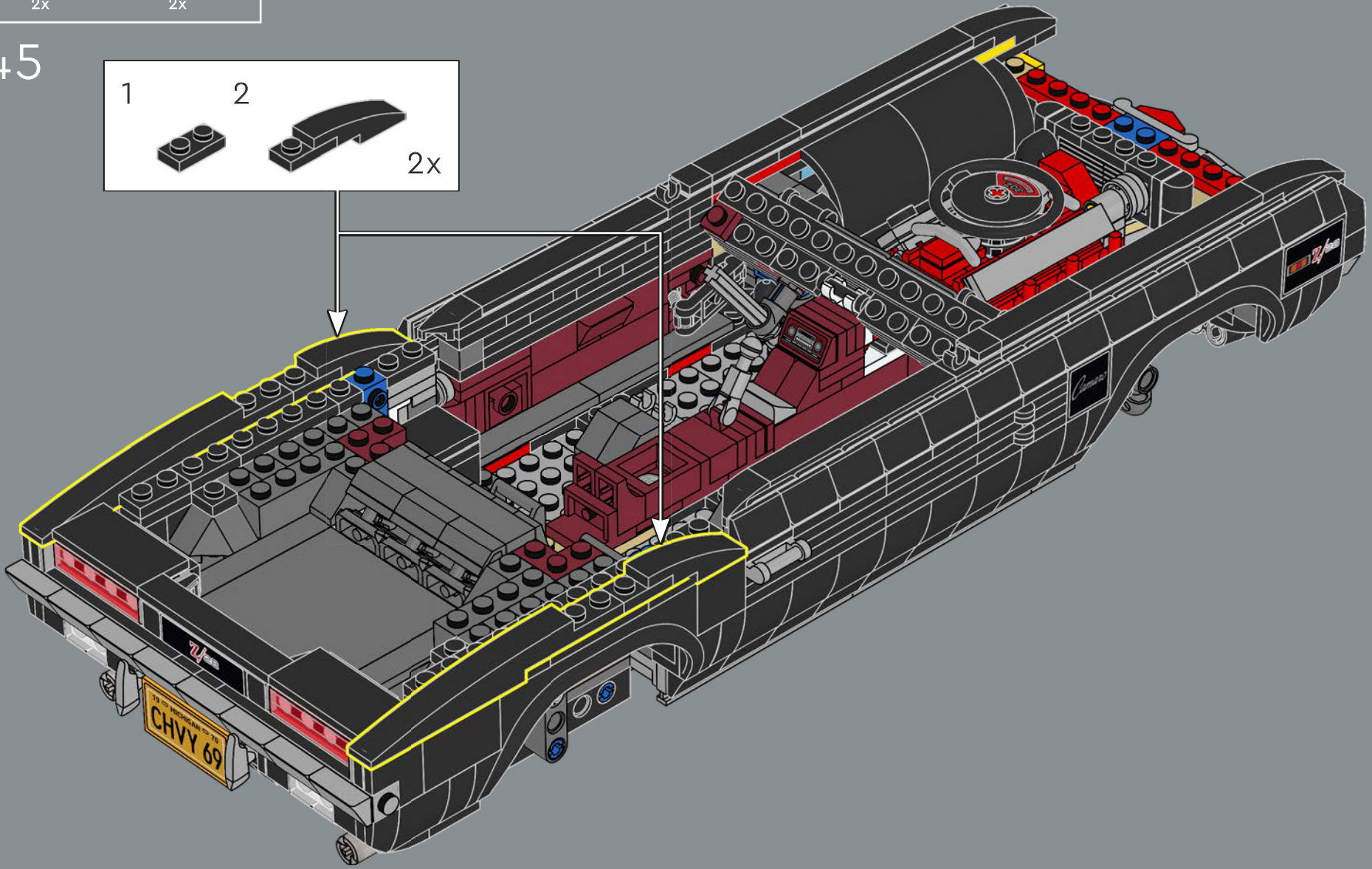
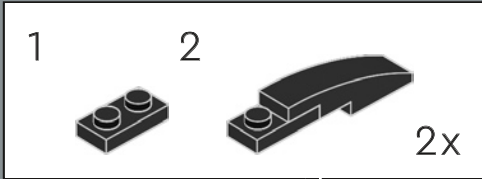

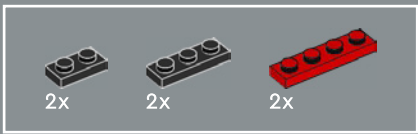

246

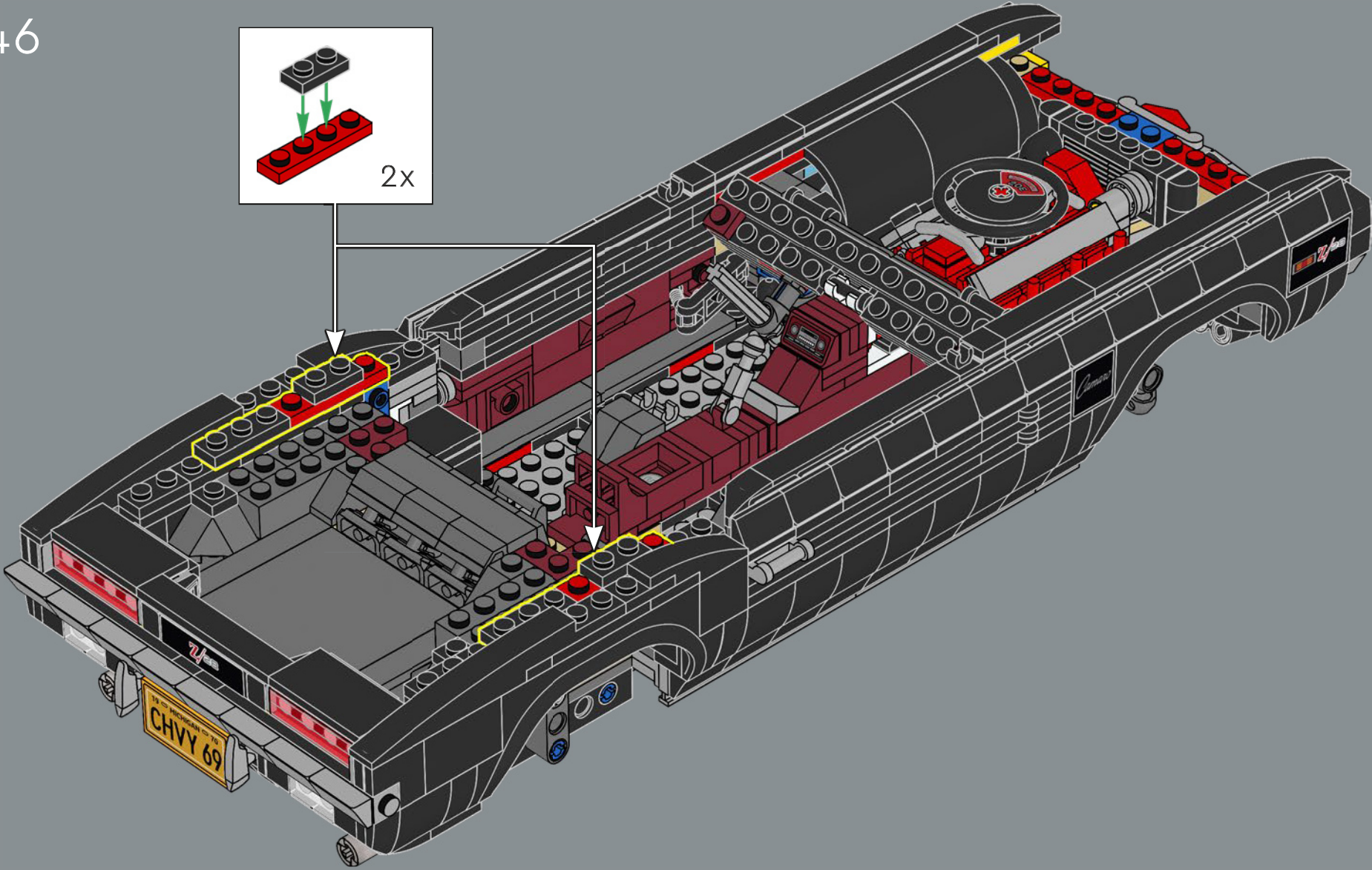
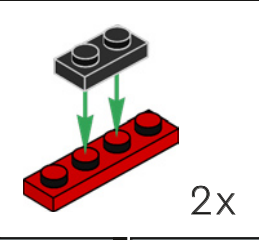

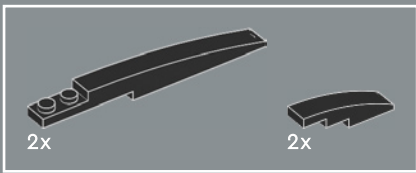

247

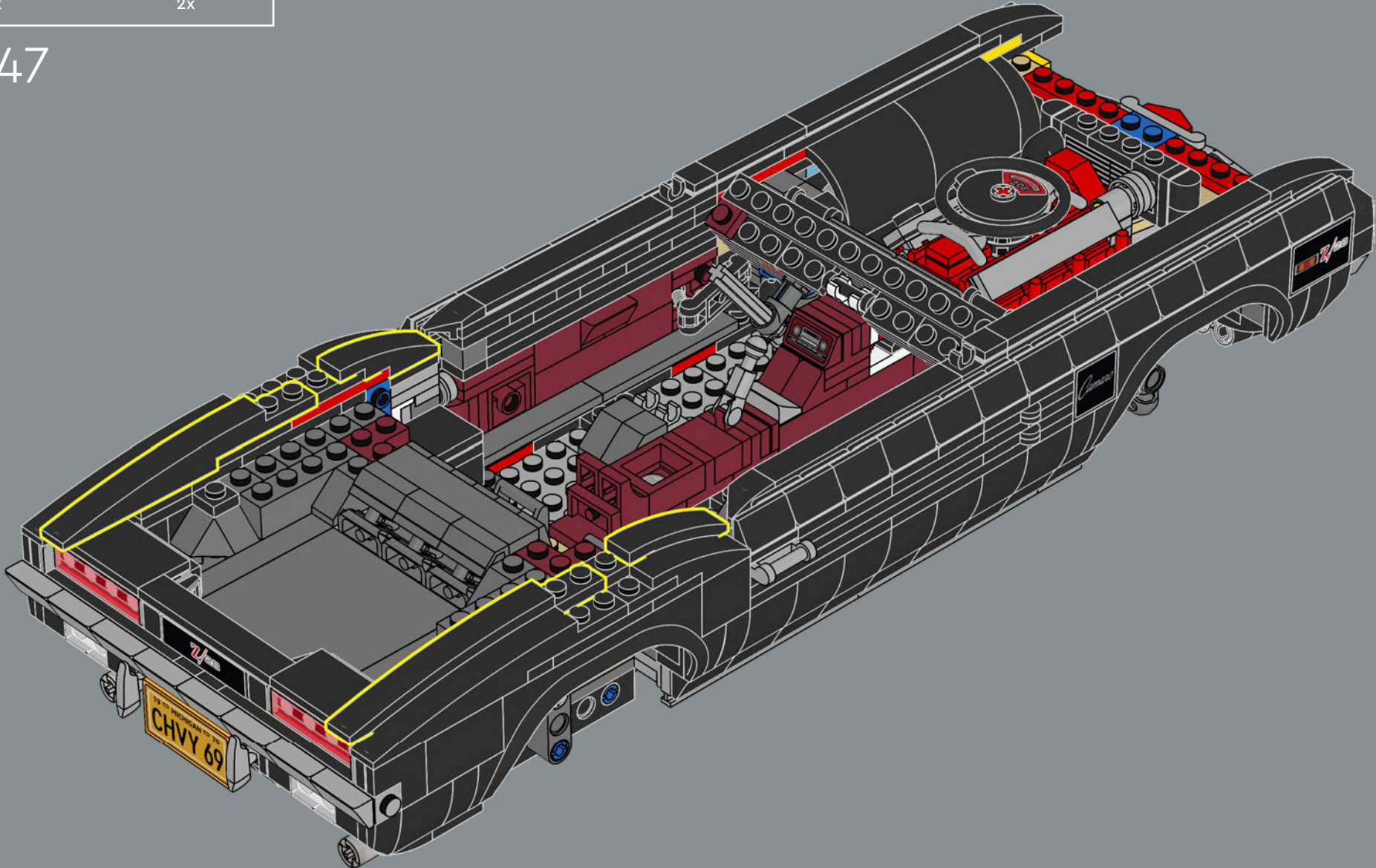

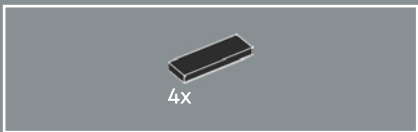

248

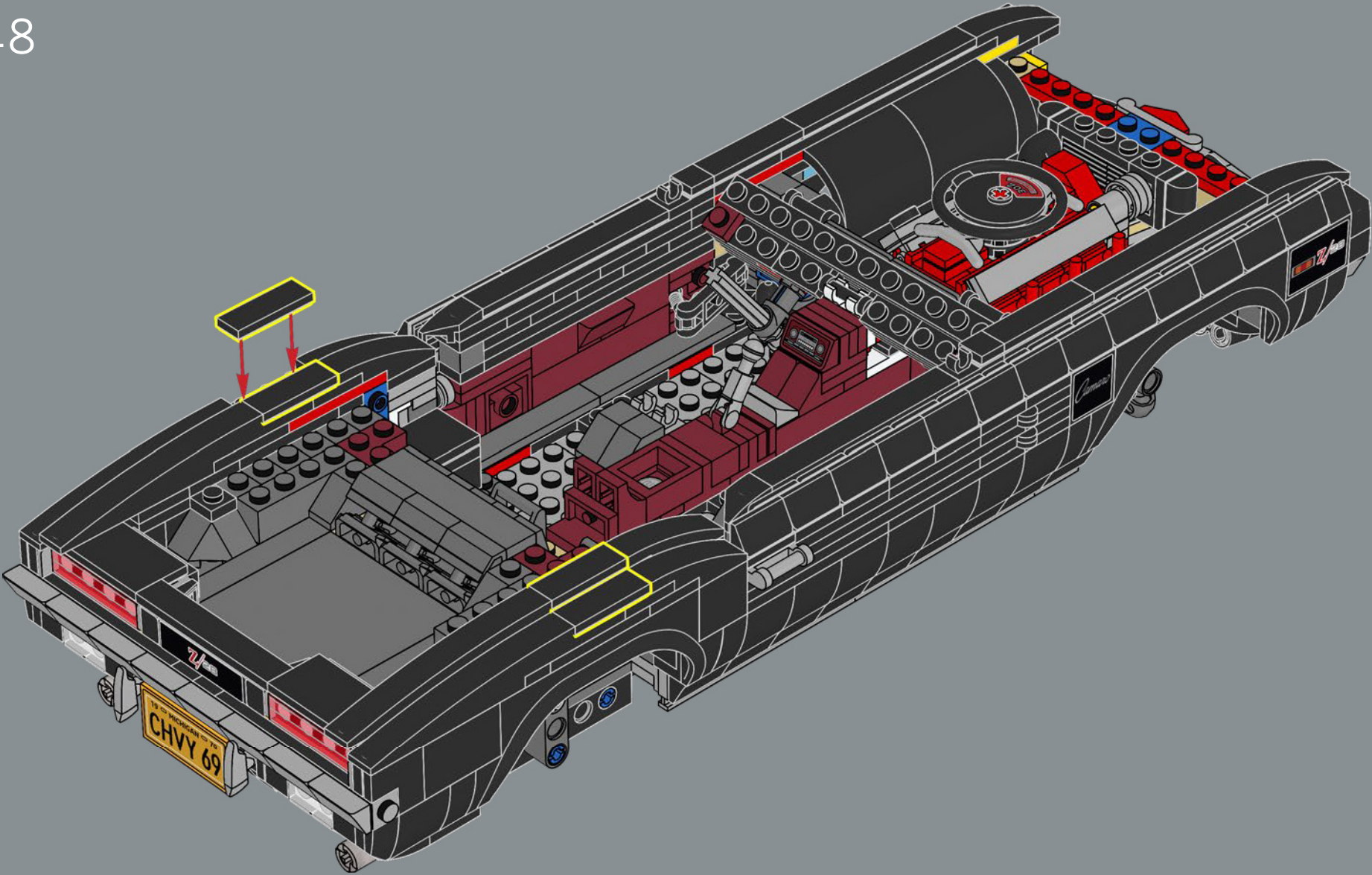

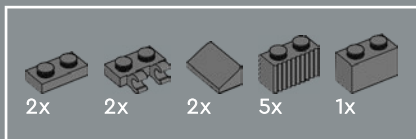

249

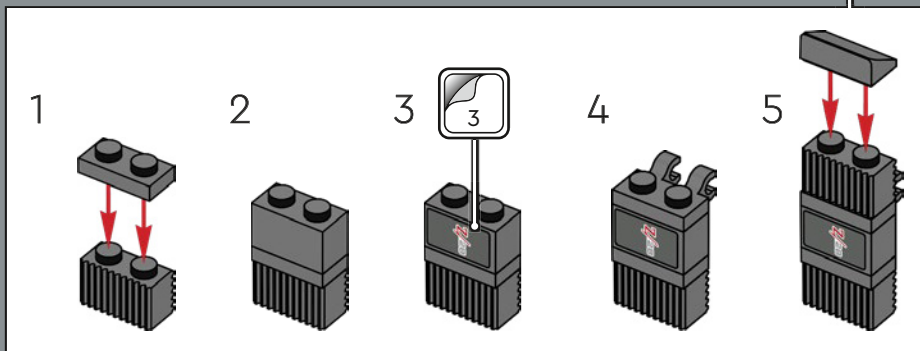
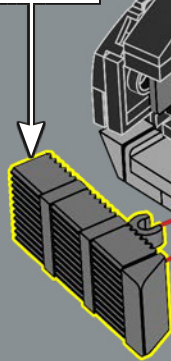
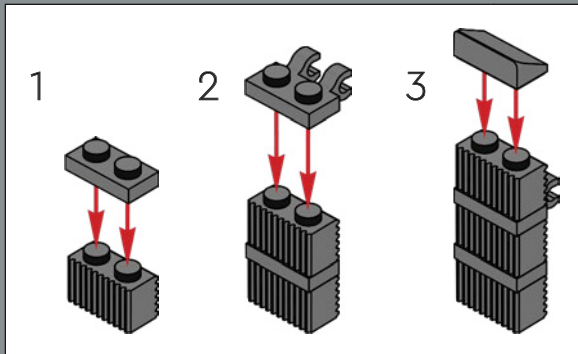

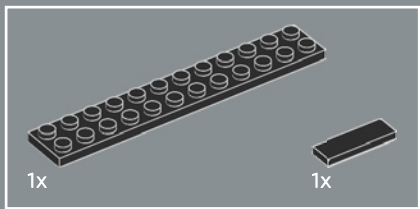

250

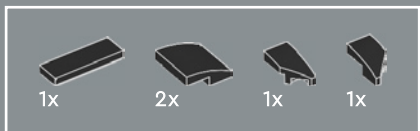
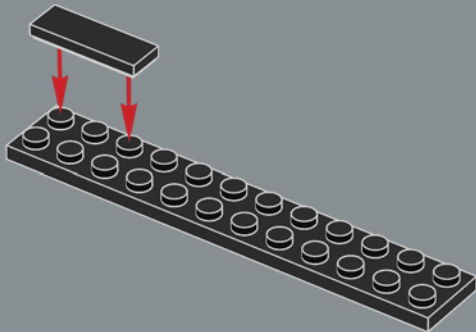

251

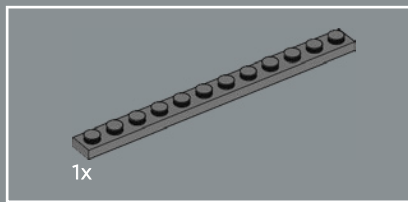
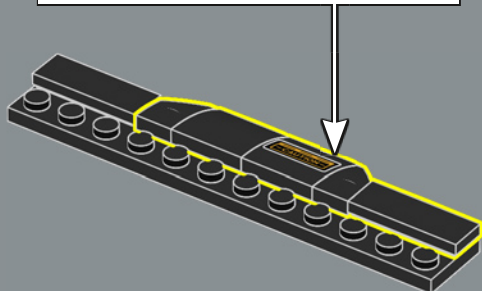
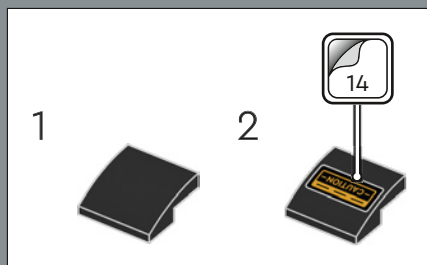

252

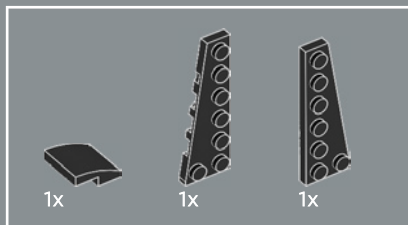
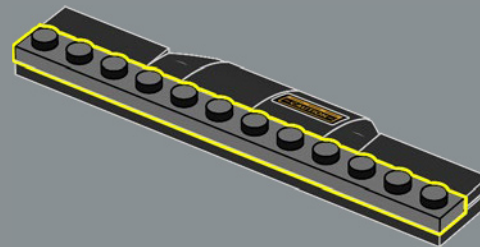

253

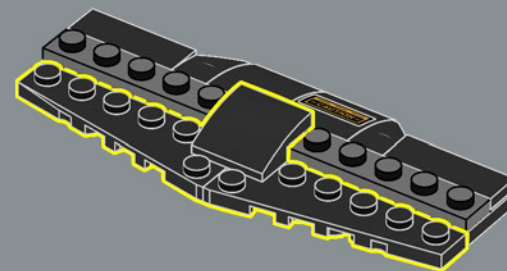



254

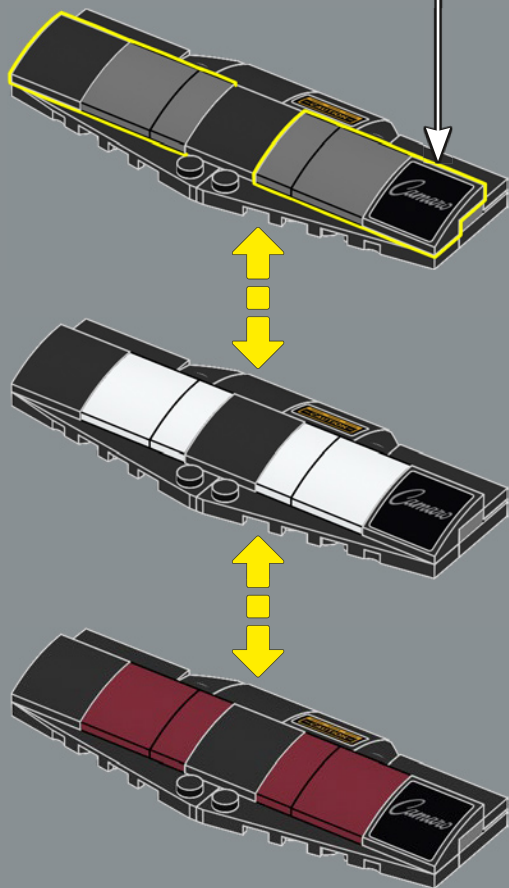
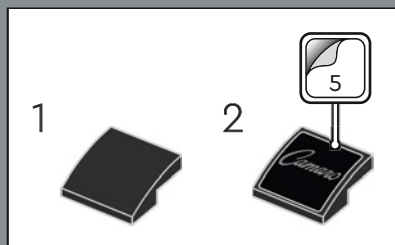

255

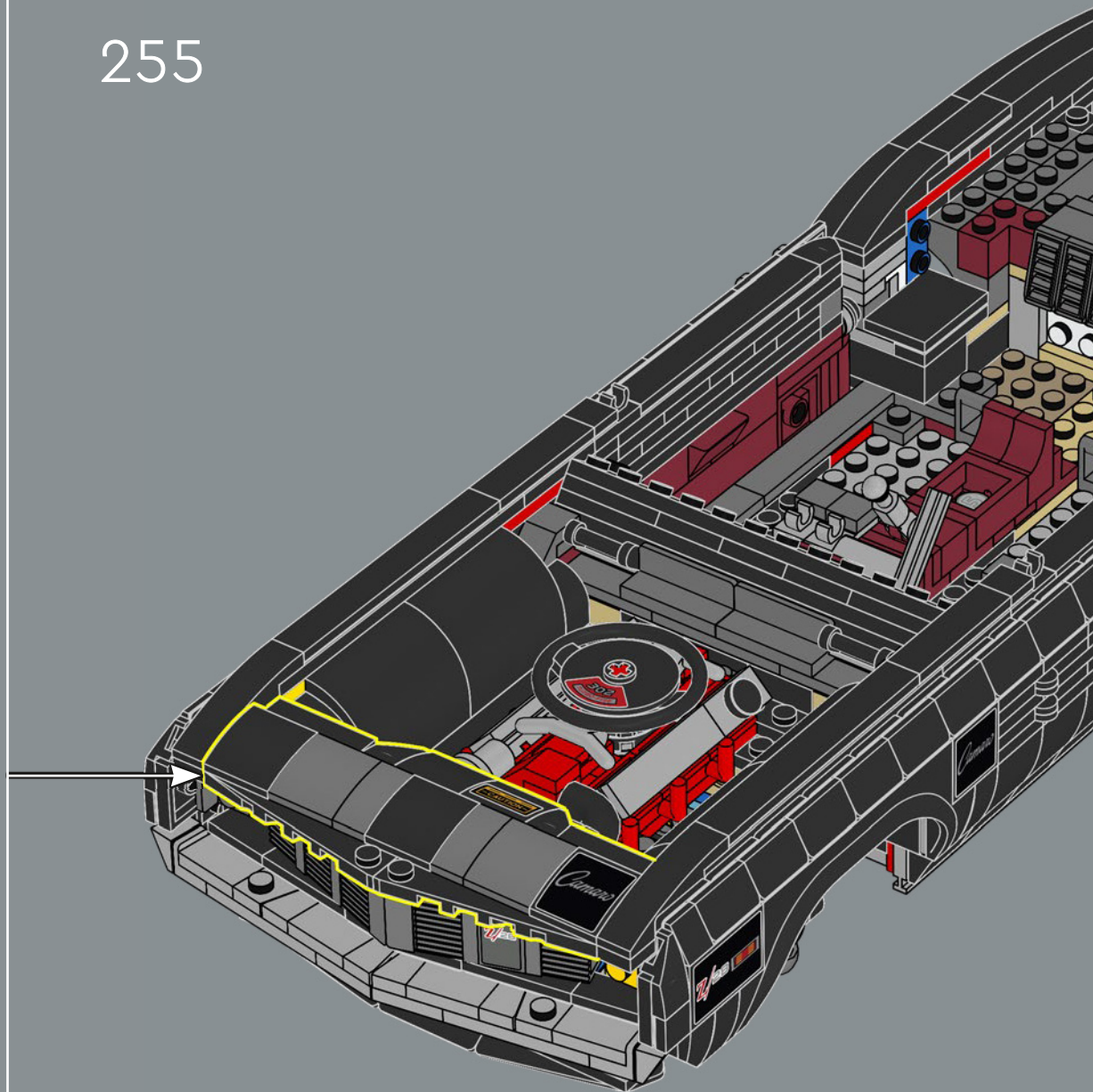

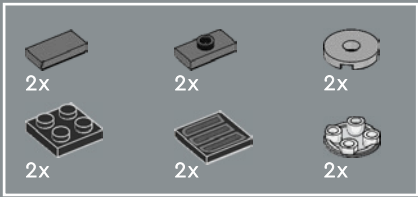

256

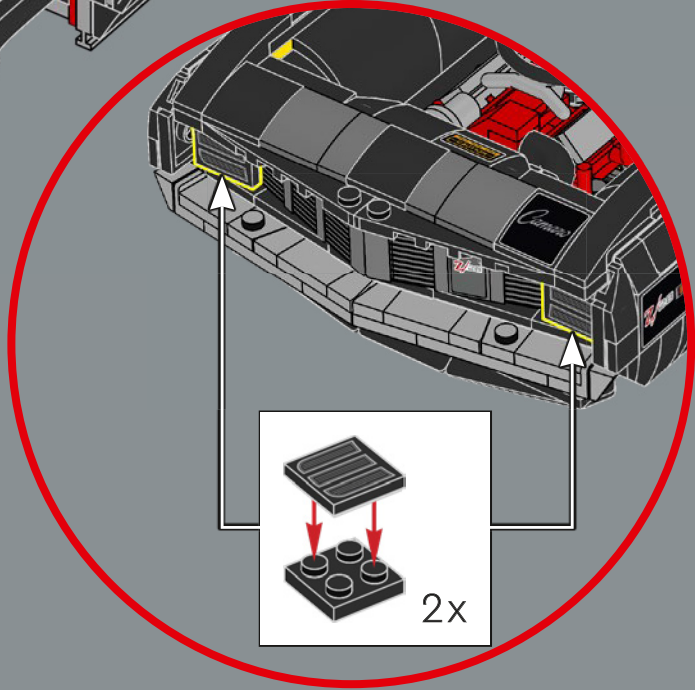
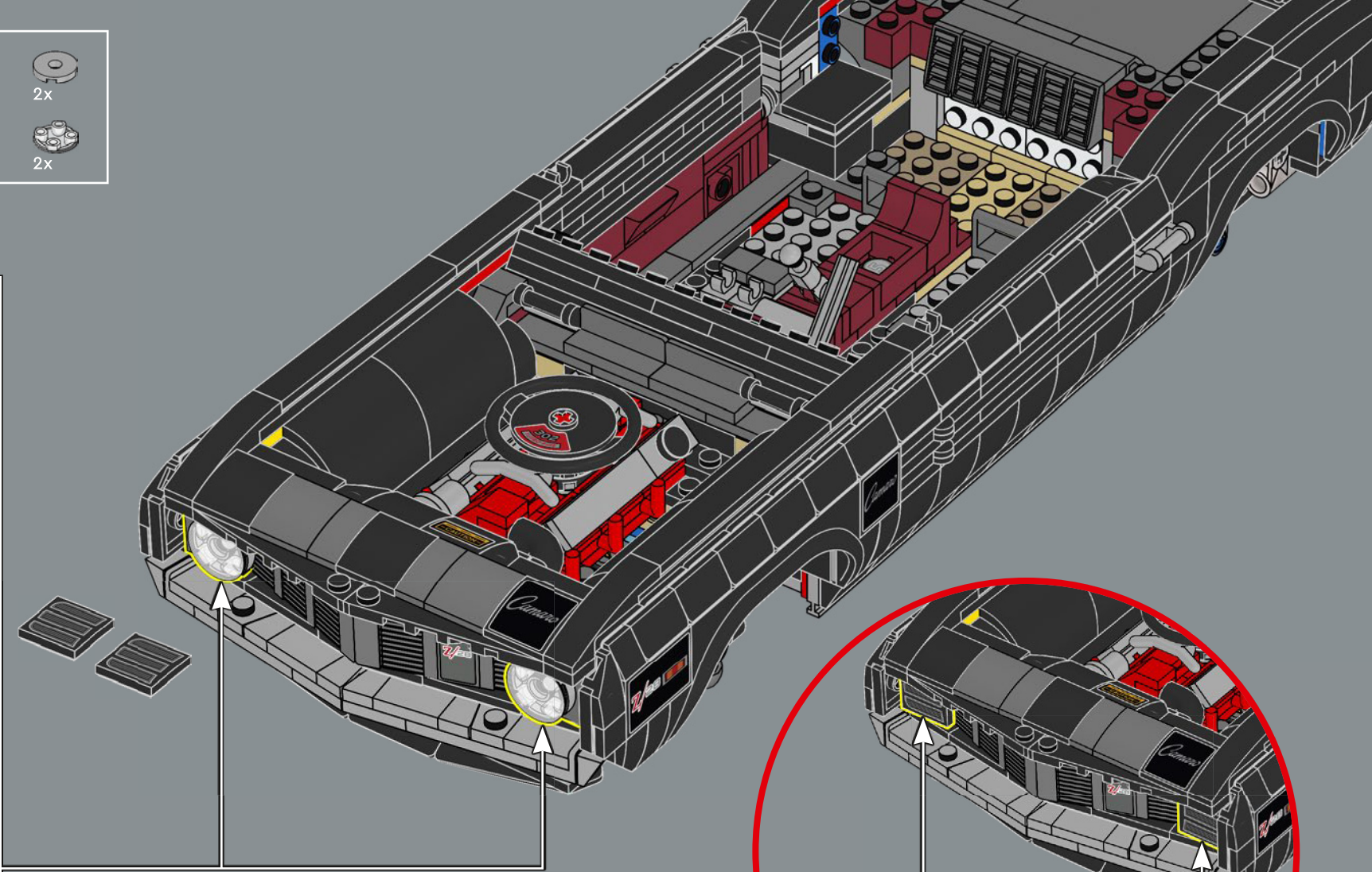
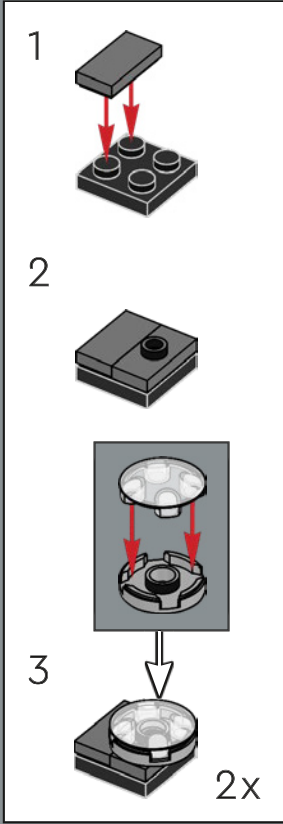

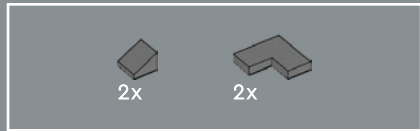

257

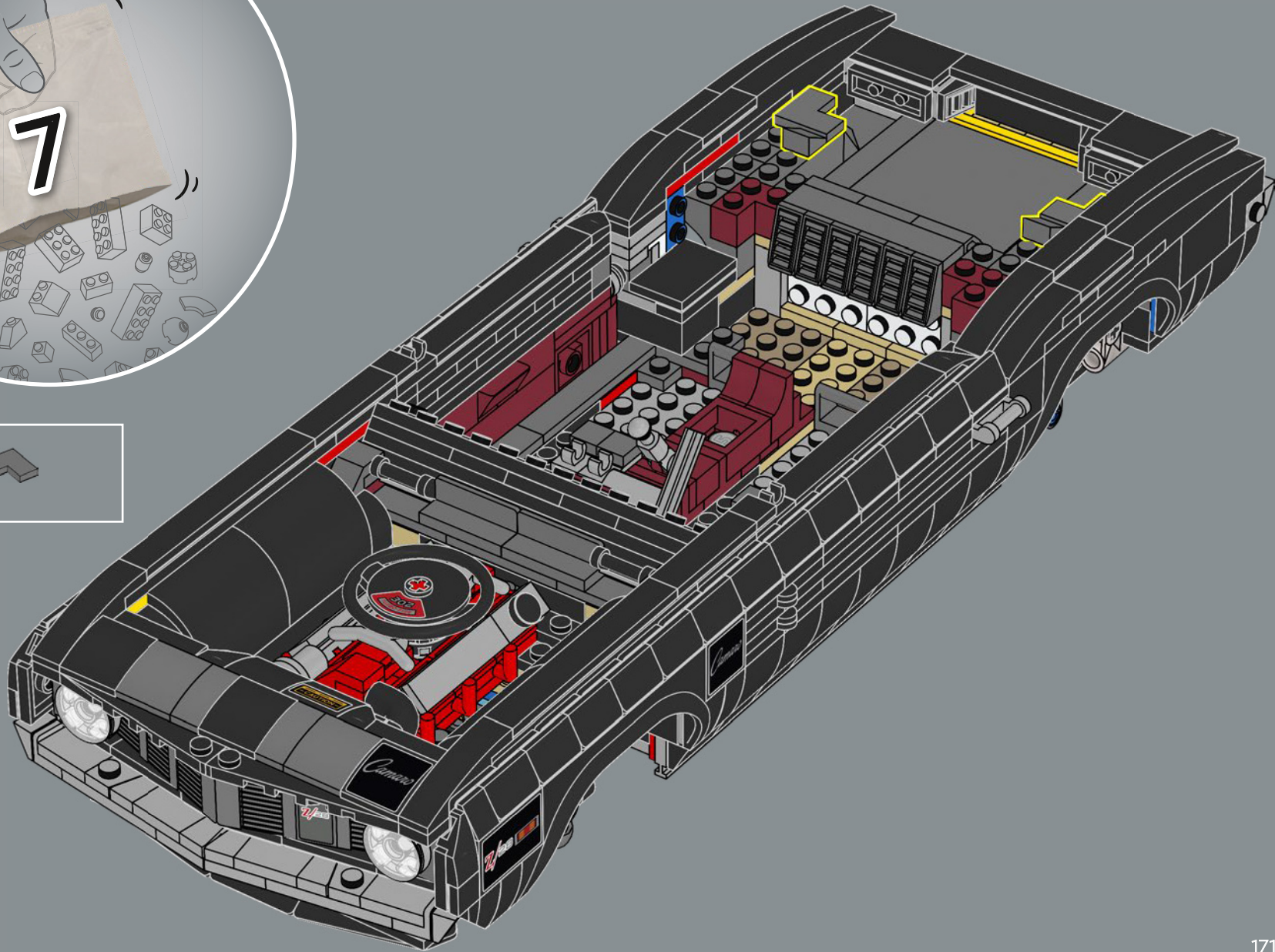

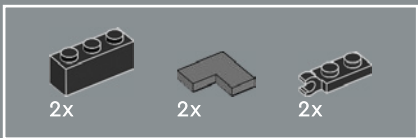

258

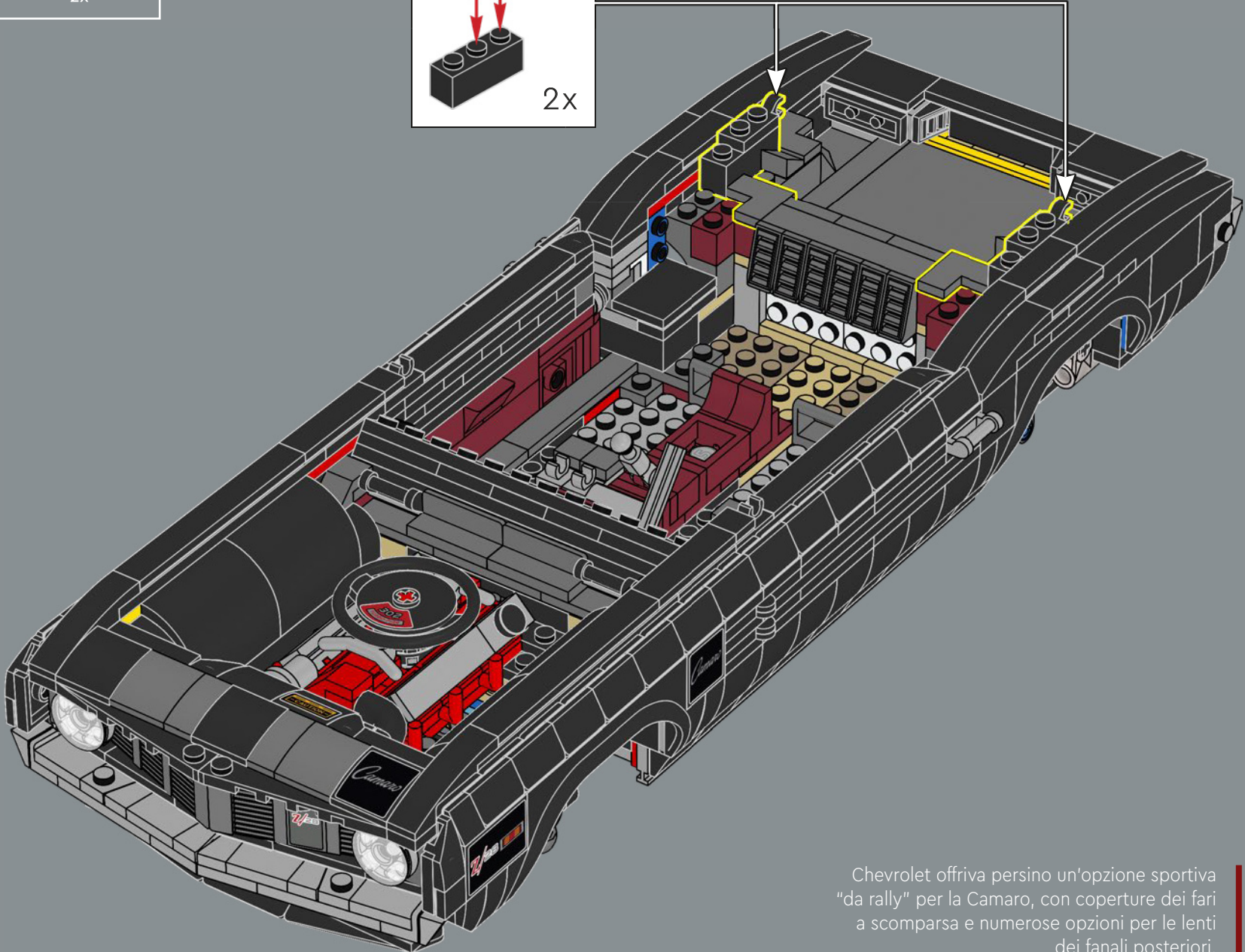
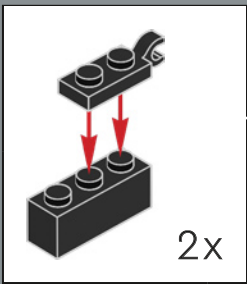

Chevrolet offriva persino un'opzione sportiva "da rally" per la Camaro, con coperture dei fari a scomparsa e numerose opzioni per le lenti dei fanali posteriori.

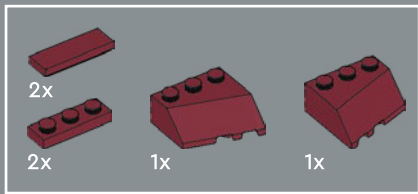

259

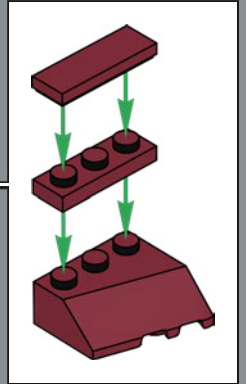
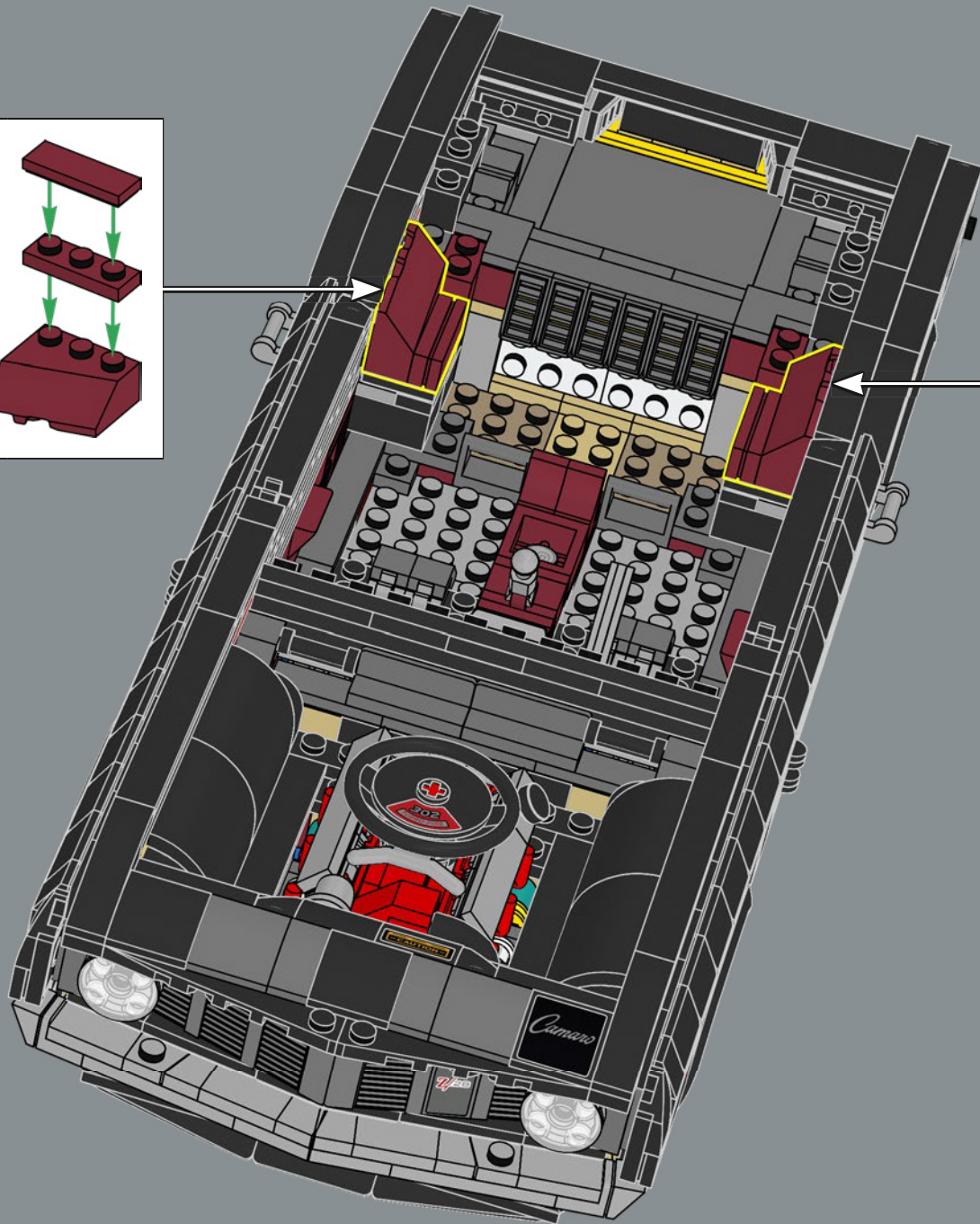
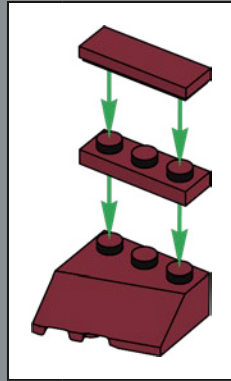

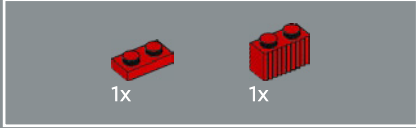

260

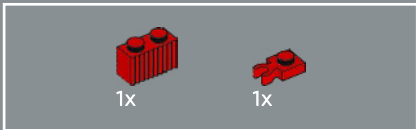

261

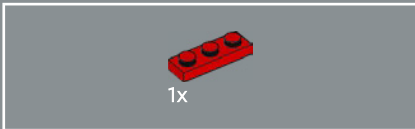
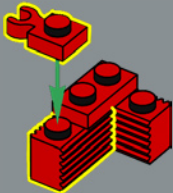

262

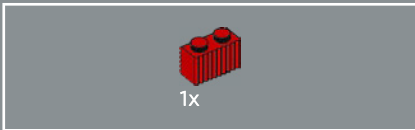
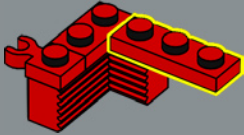

263

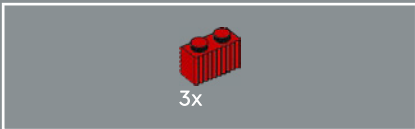
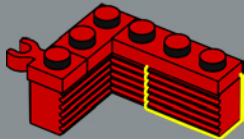

264

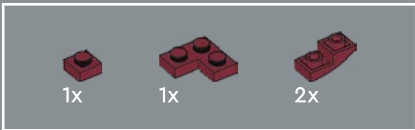
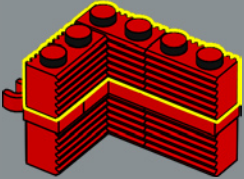

265

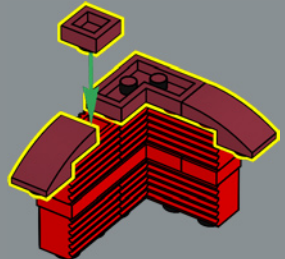

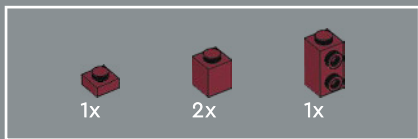

266

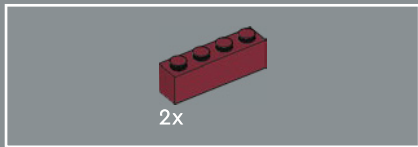
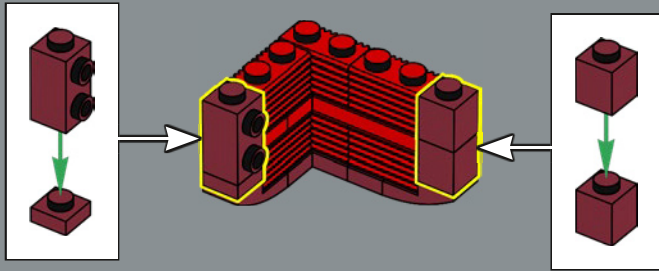

267

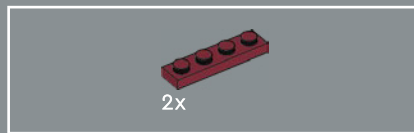
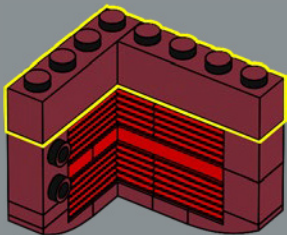

268

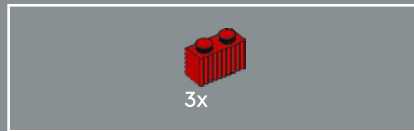
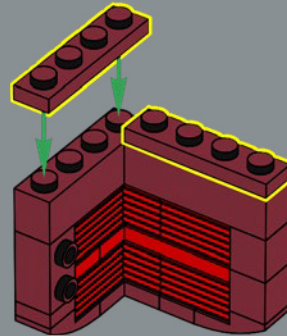

269

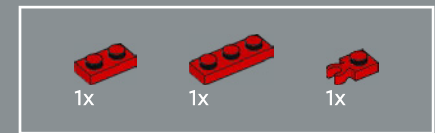
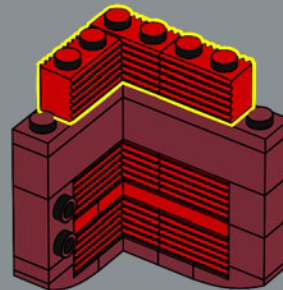

270

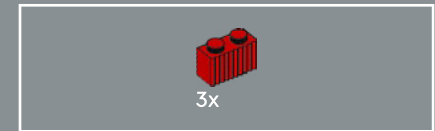
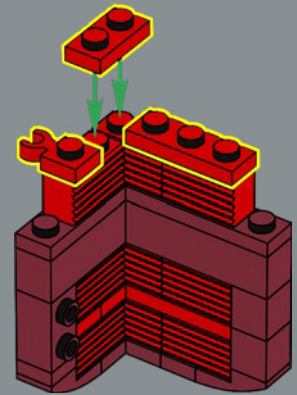

271

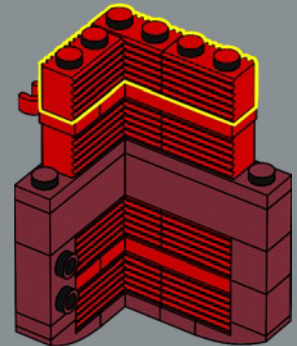



4x

272

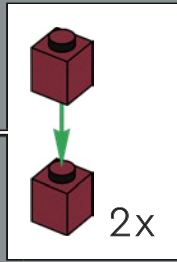
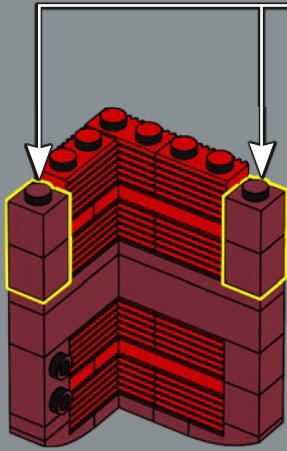

2x

1x

2x

1x

273

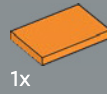
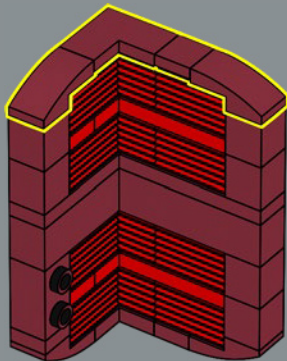

1x

274



15

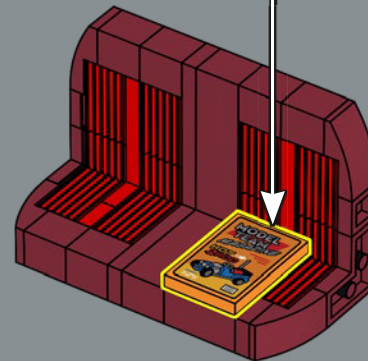

275

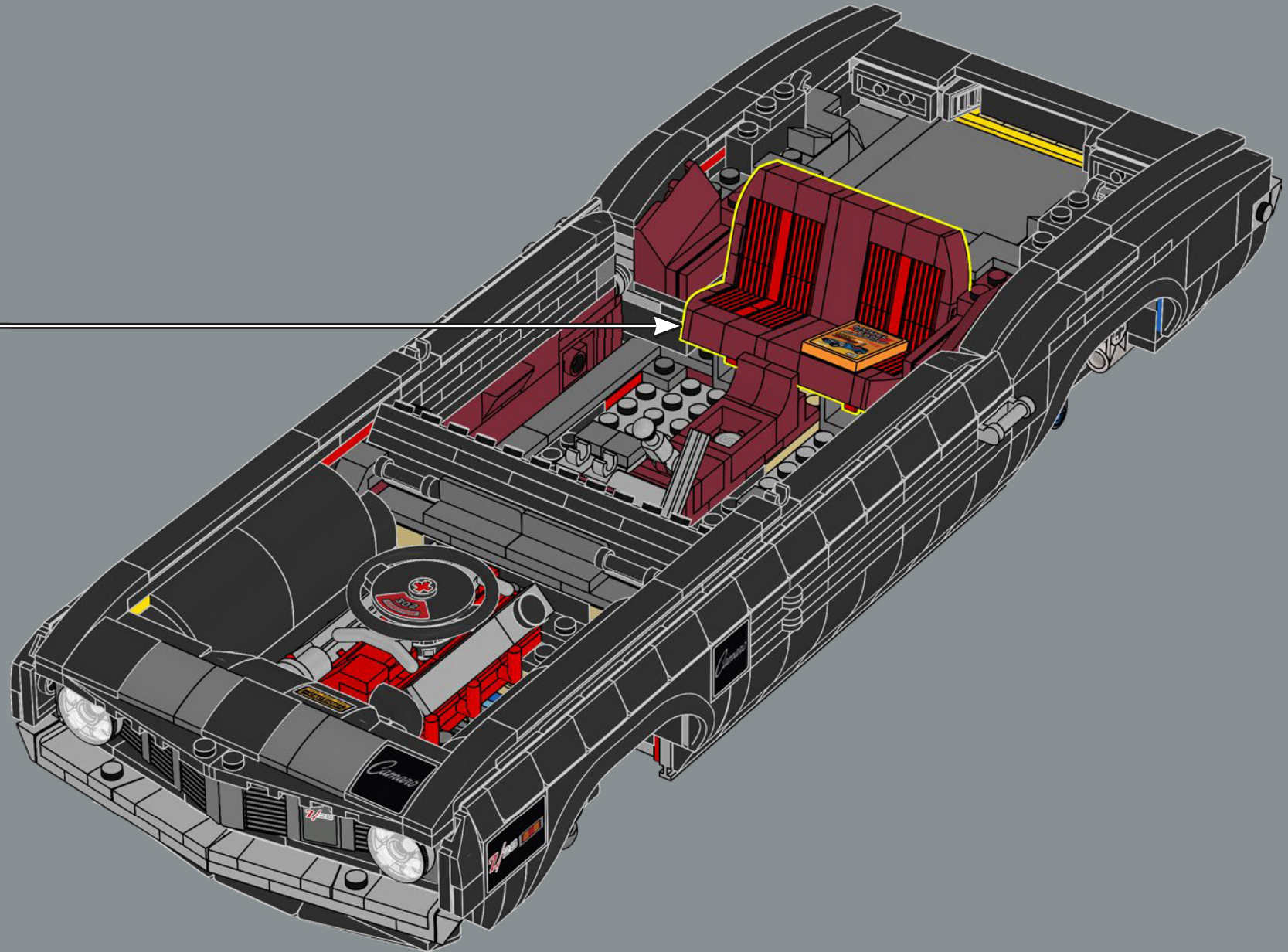

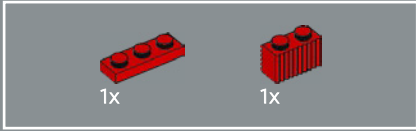

276

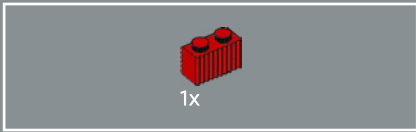
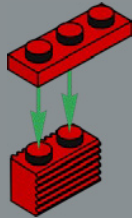

277

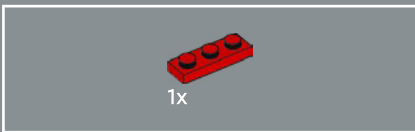
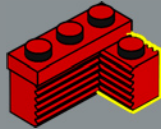

278

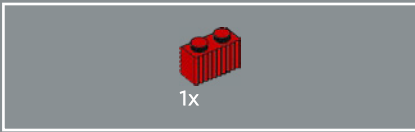
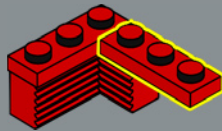

279

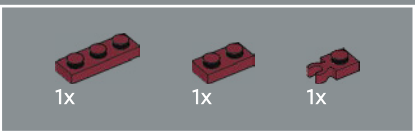
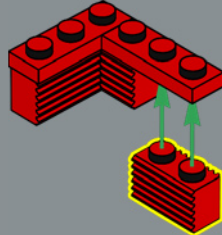

280

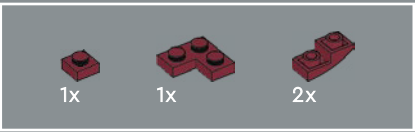
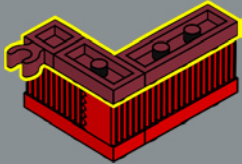

281

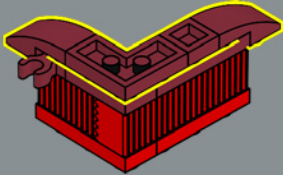



282

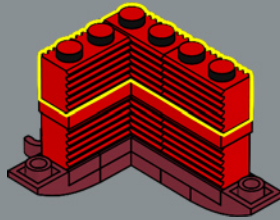

283

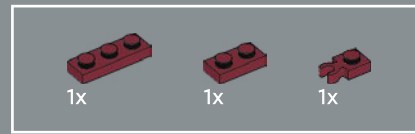
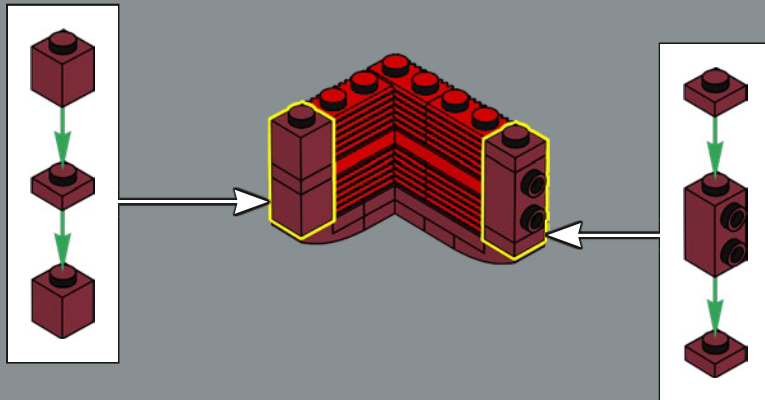

284

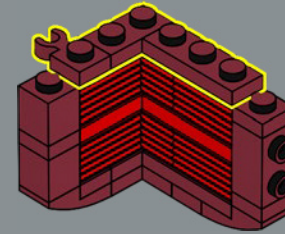

285

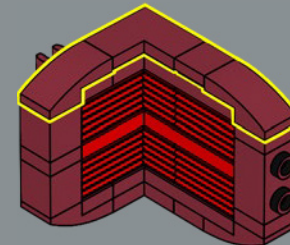



1x

286

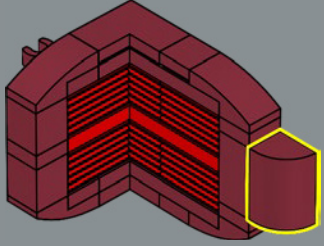

1x

287

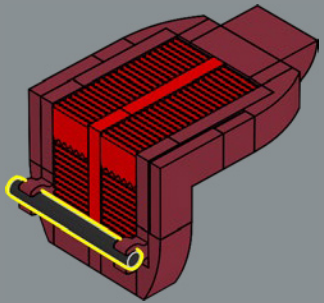

288

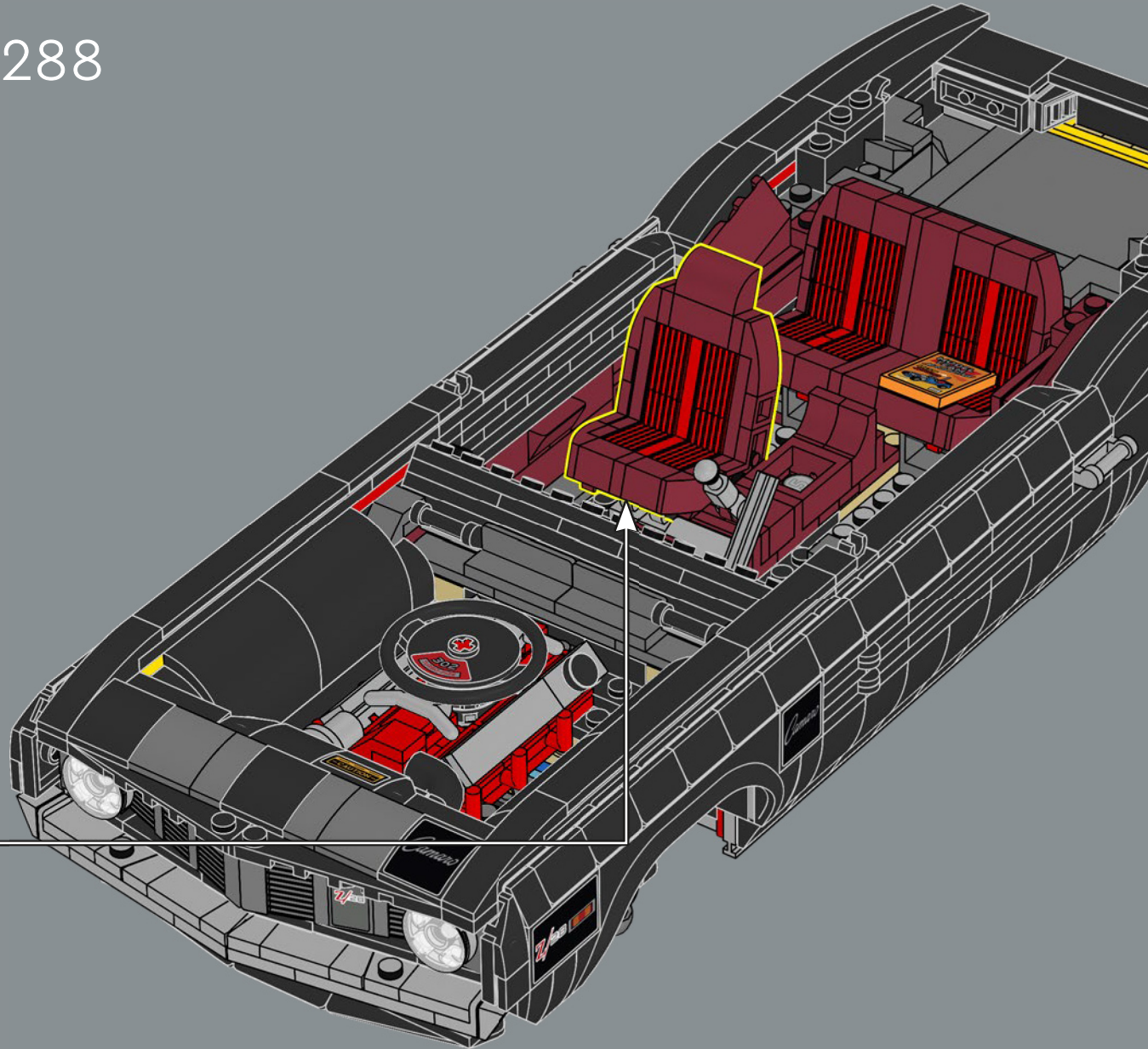

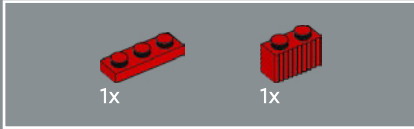

289

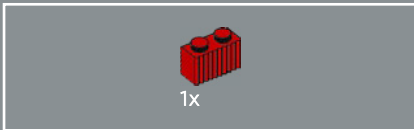
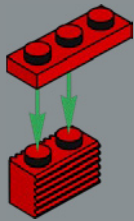

290

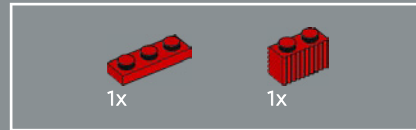
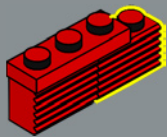

291

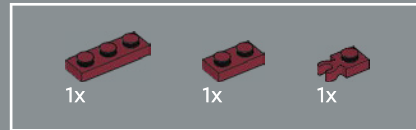
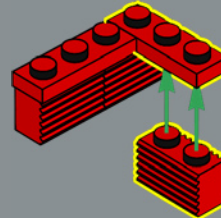

292

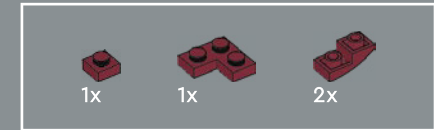
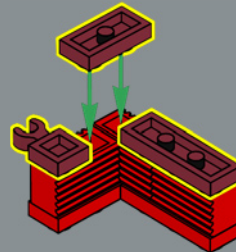

293

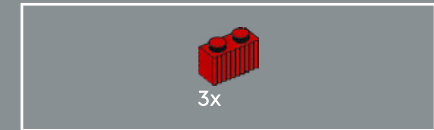
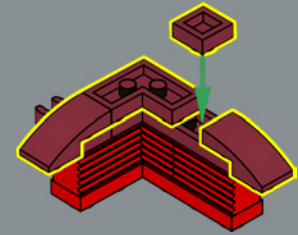

294

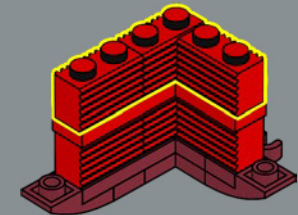



295

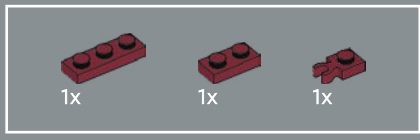
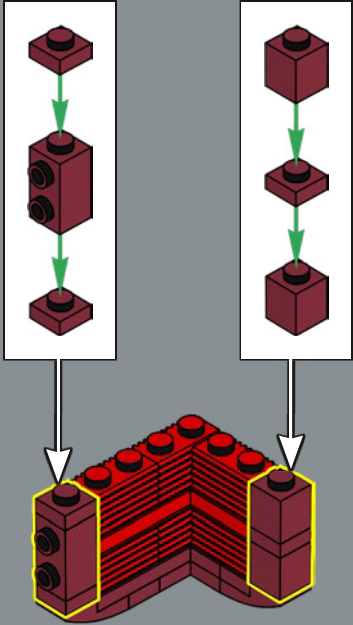

296

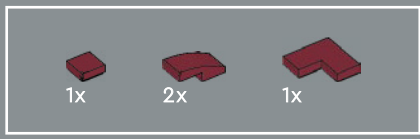
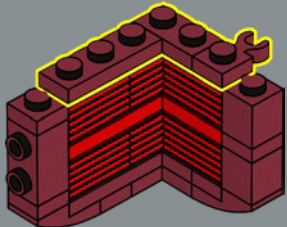

297

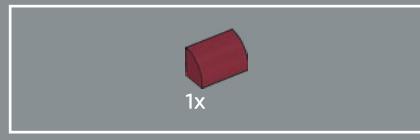
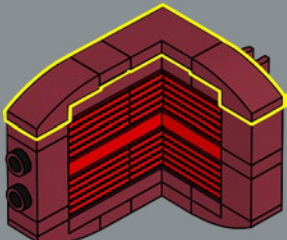

298

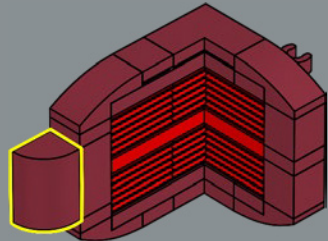

299

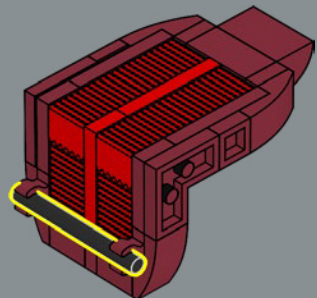

300

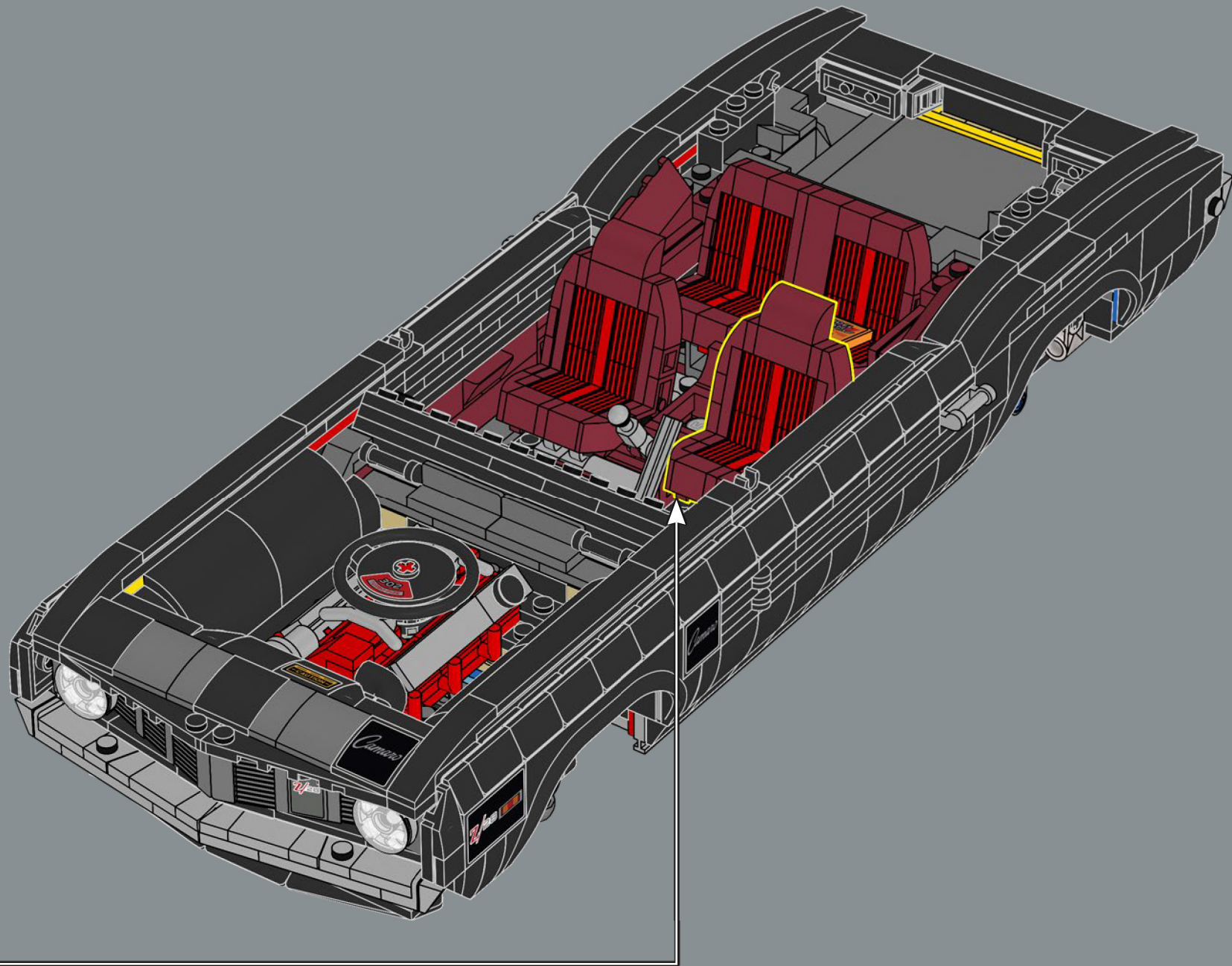

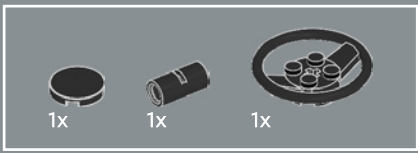

301

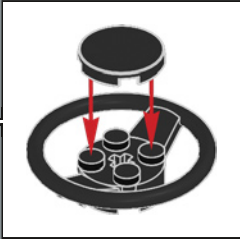
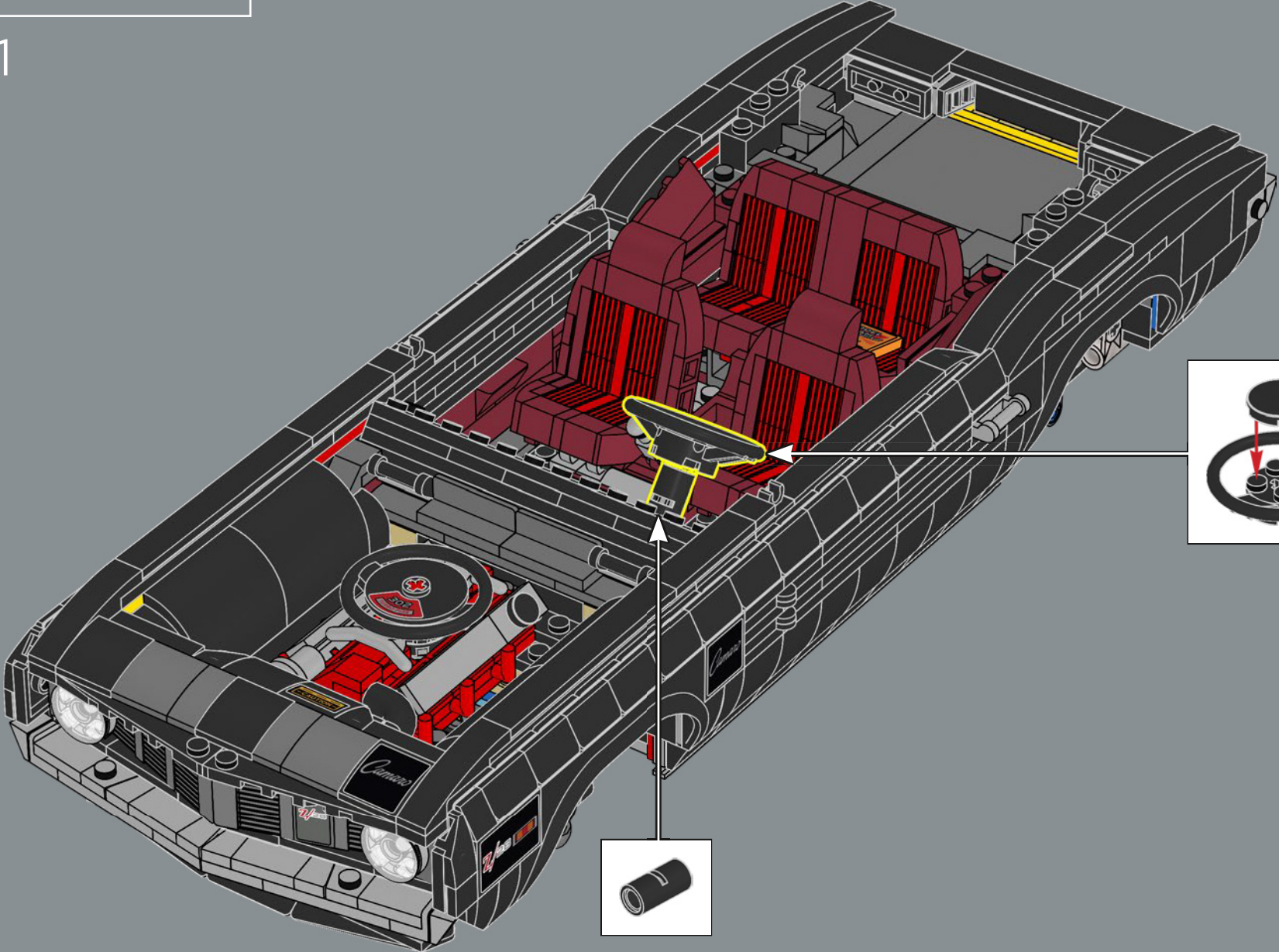

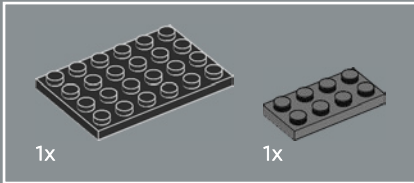
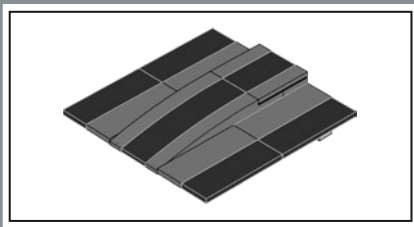

302

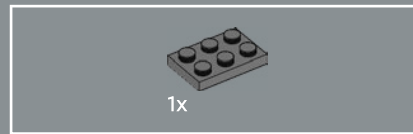
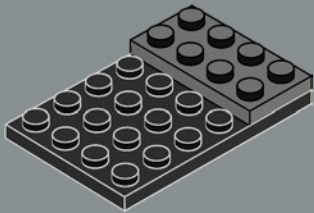

303

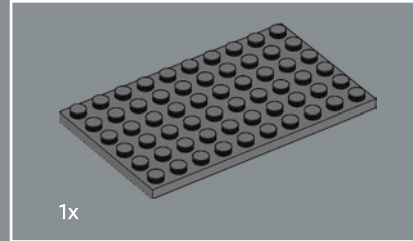
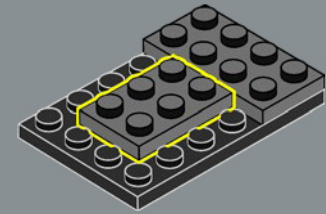

304

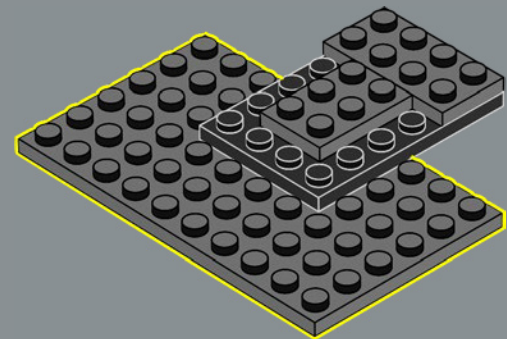

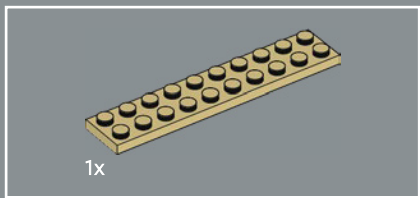

305

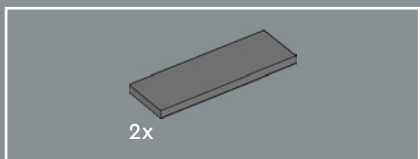
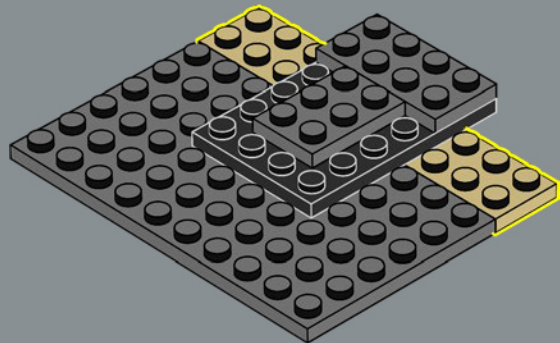

306

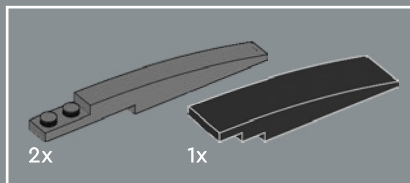
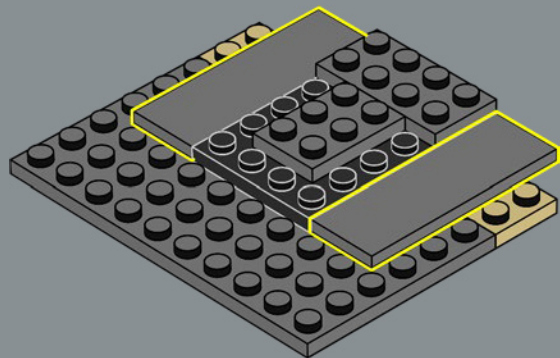

307

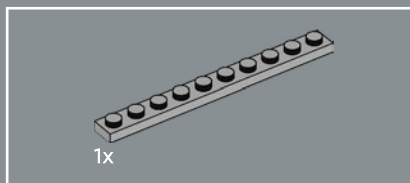
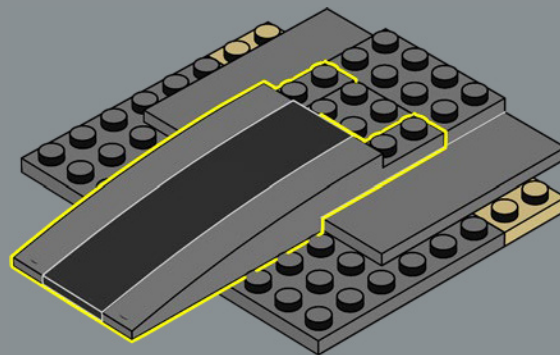

308

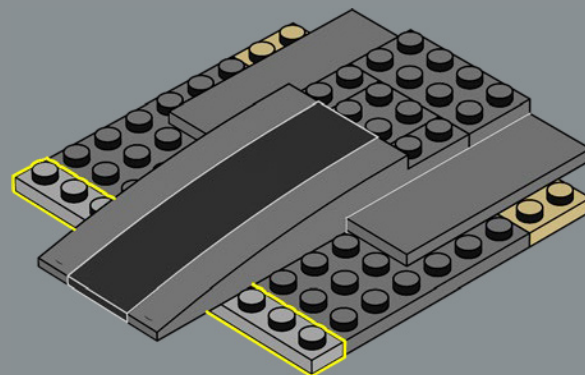

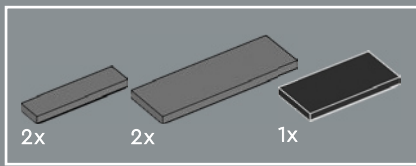

309

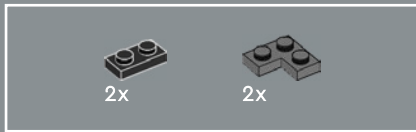
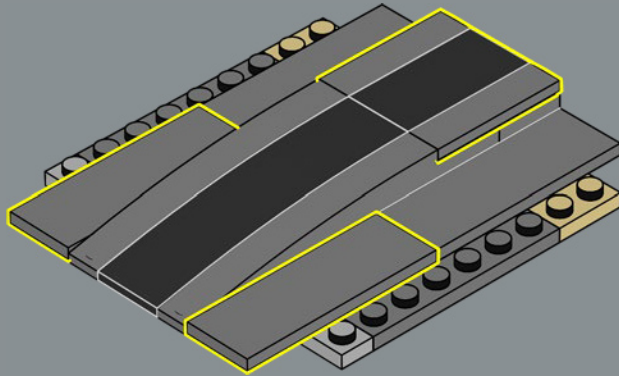

310

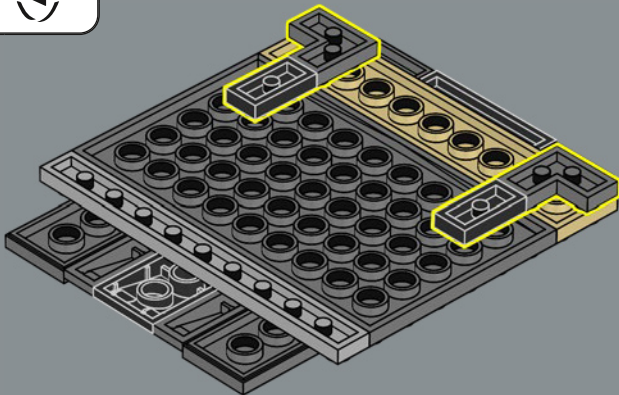

311

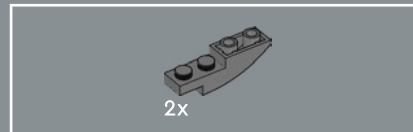
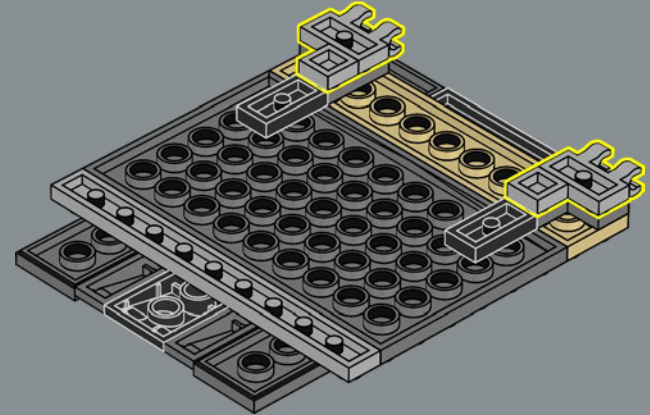

312

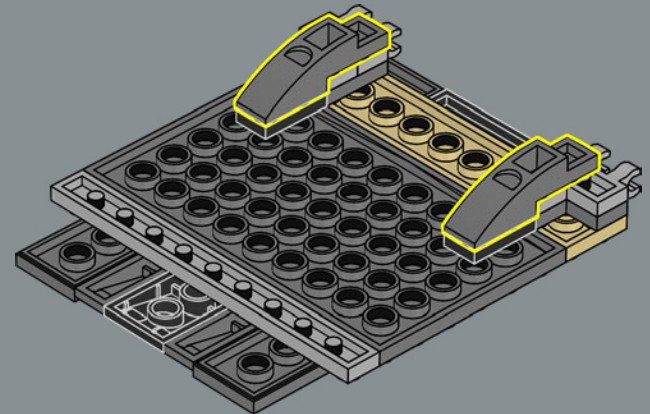

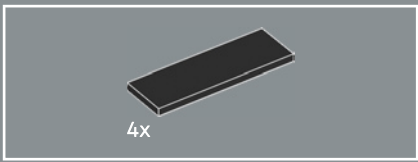

313

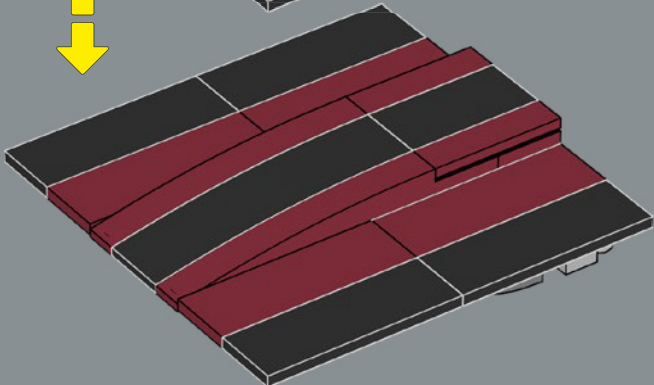
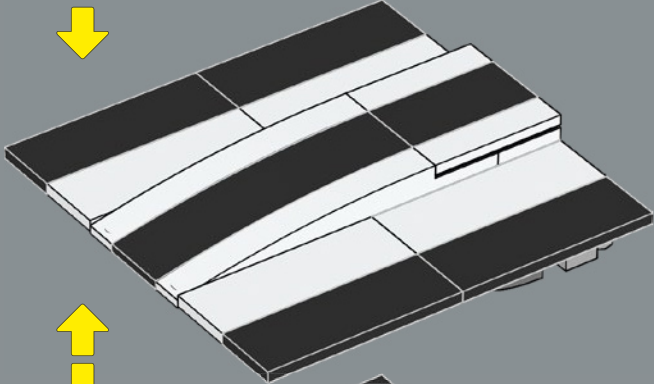
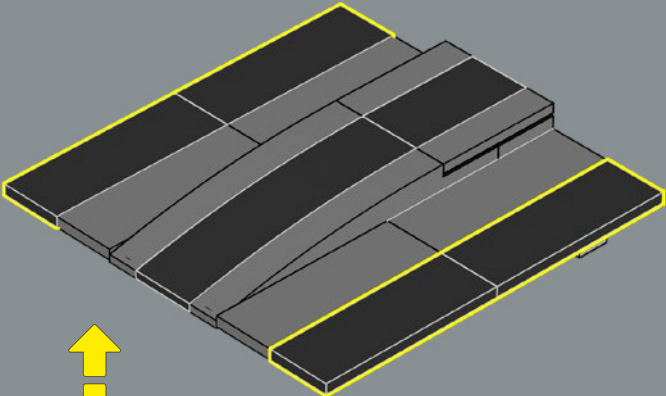

314

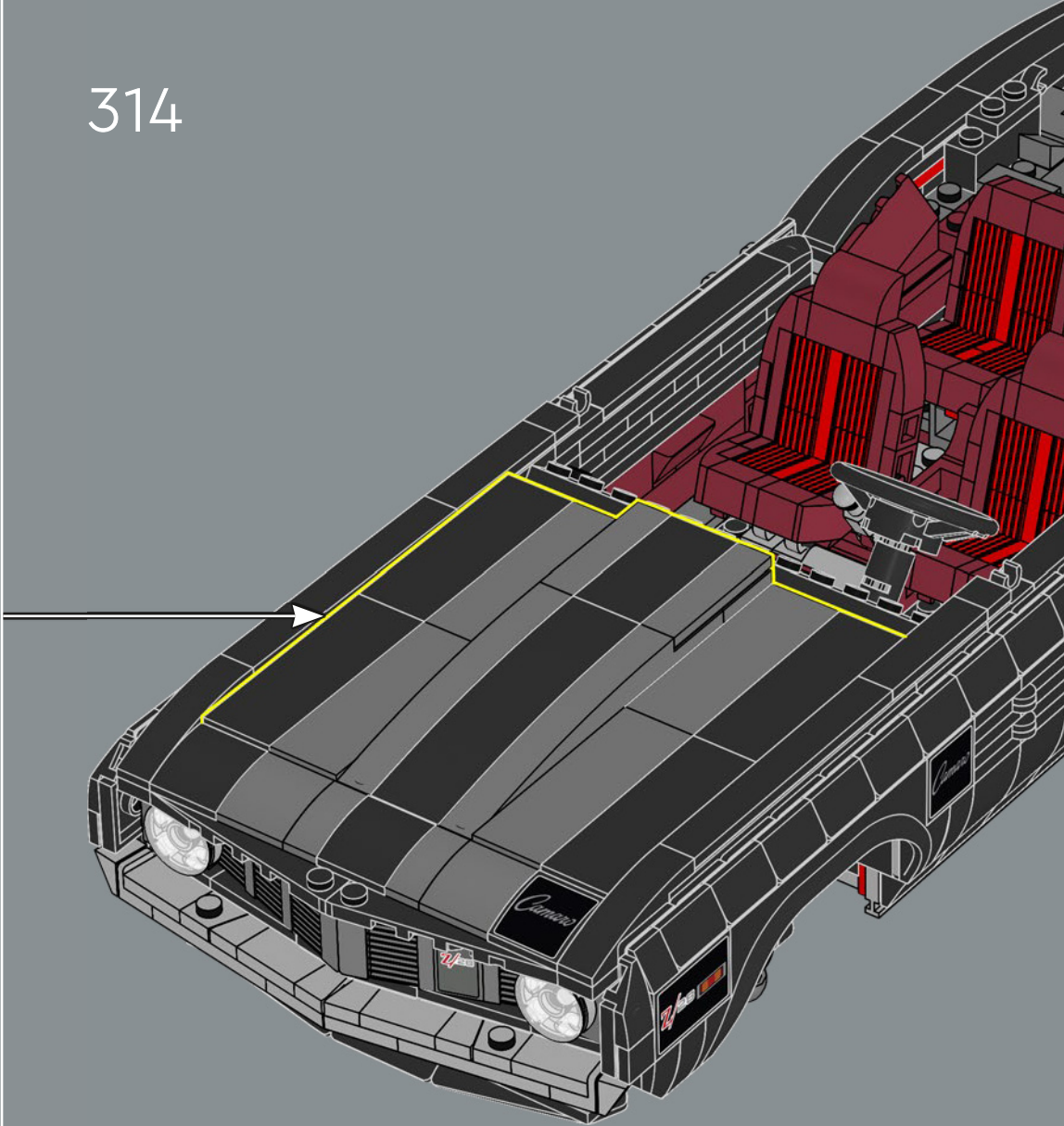

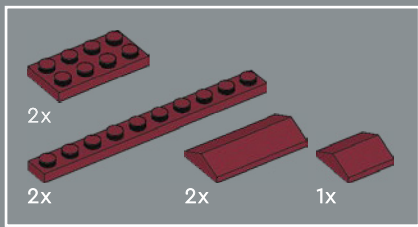

315

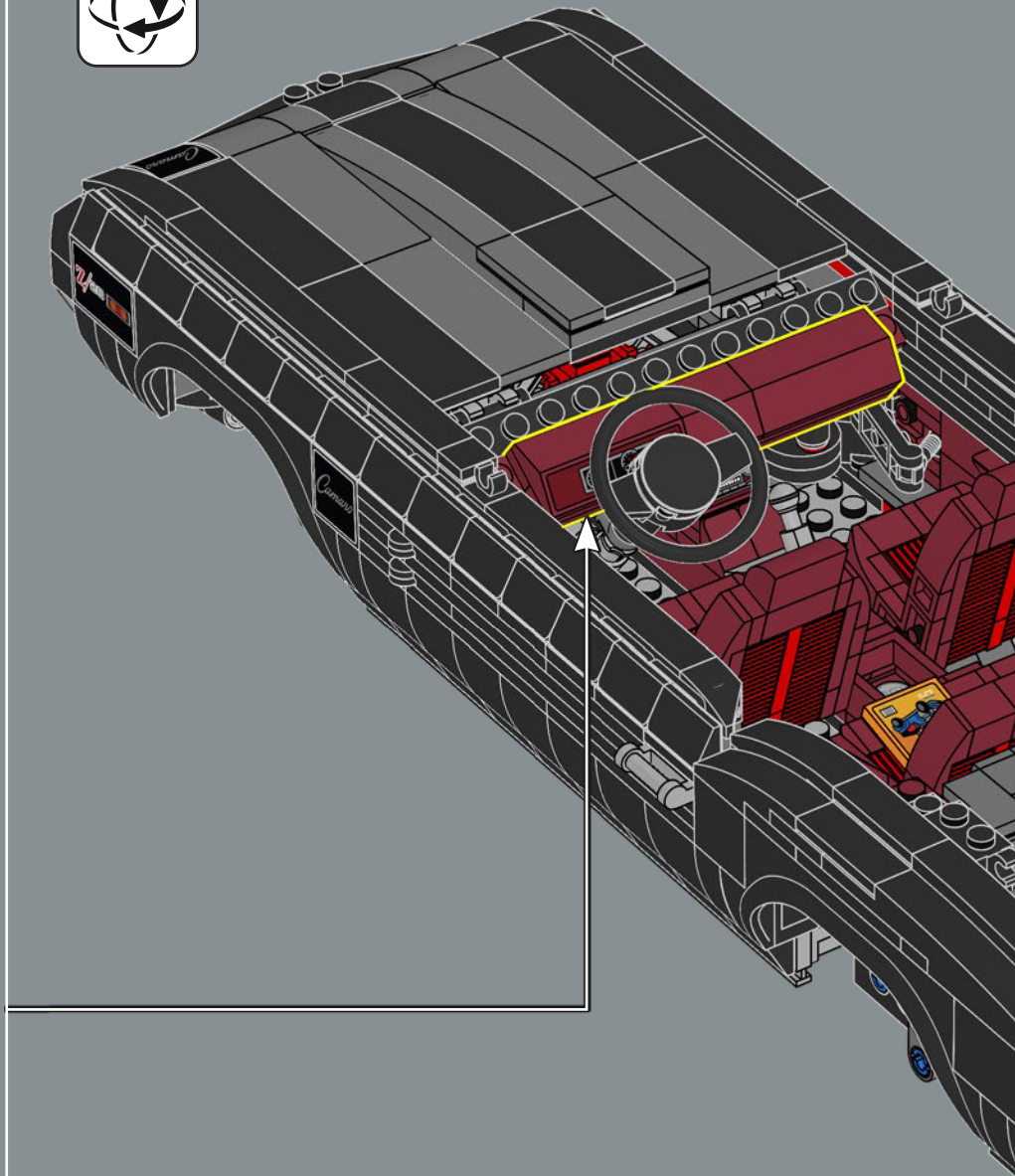
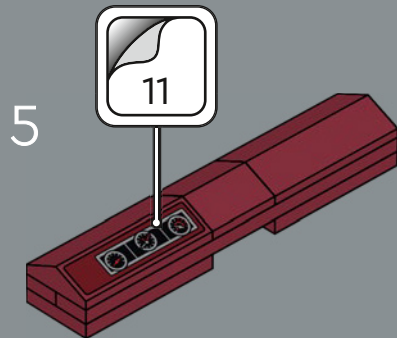
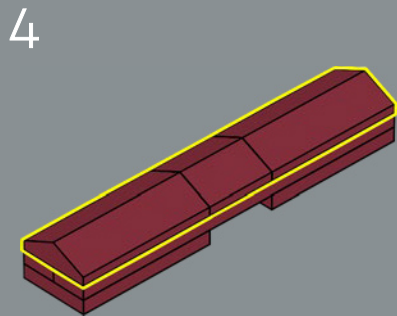
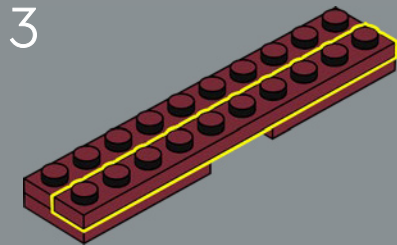
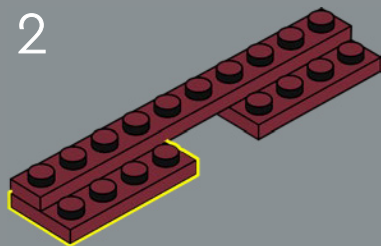
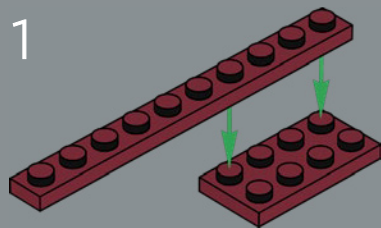

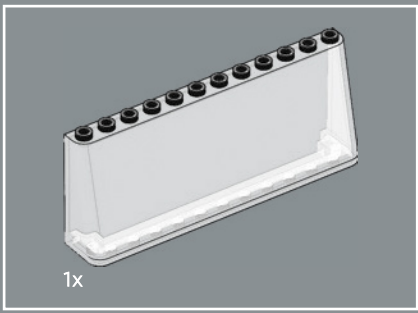

316

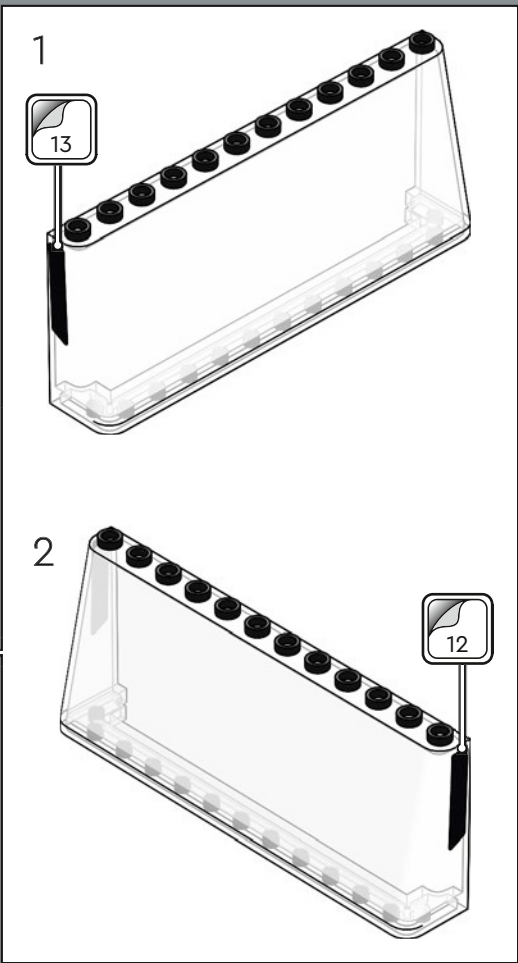
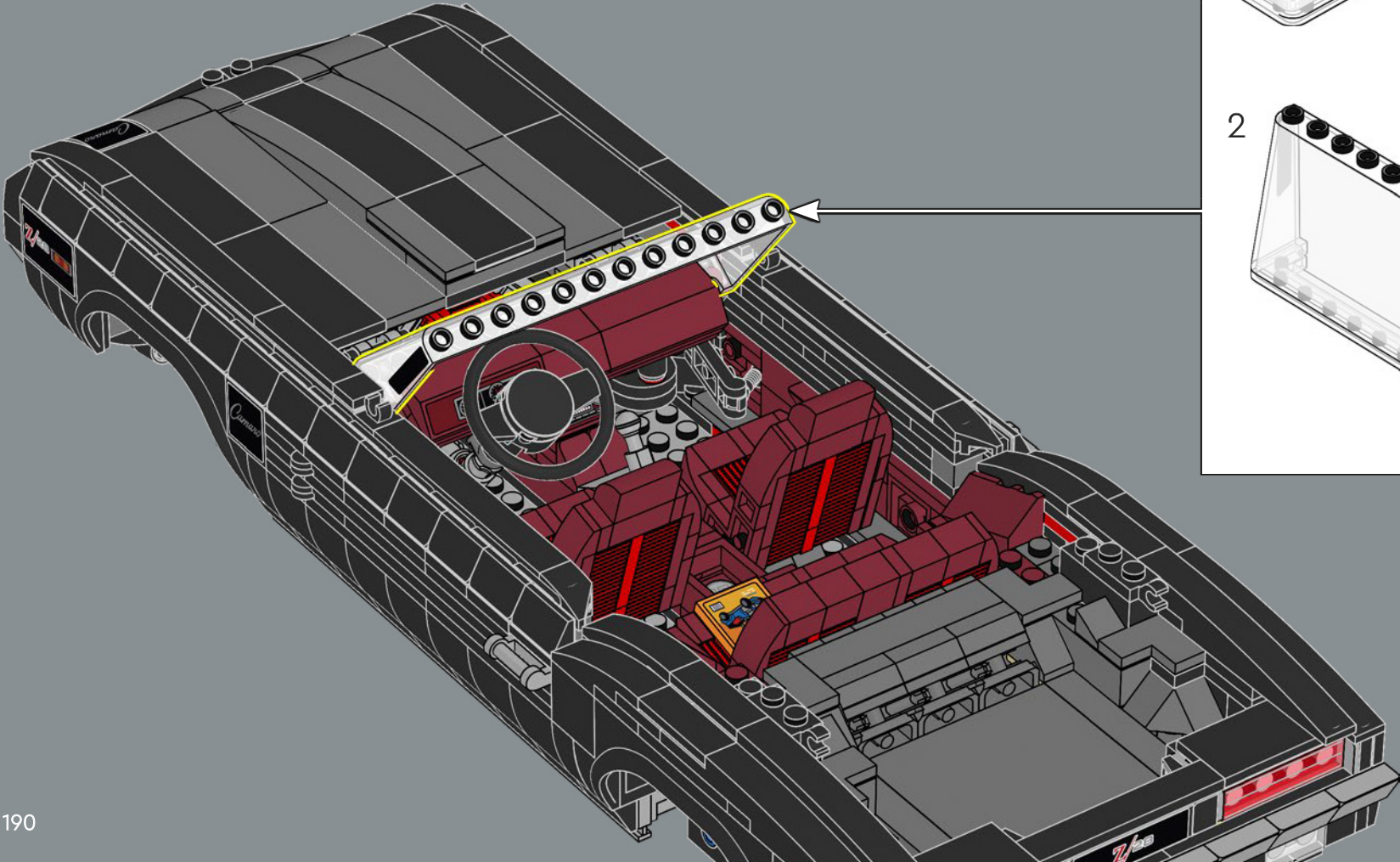

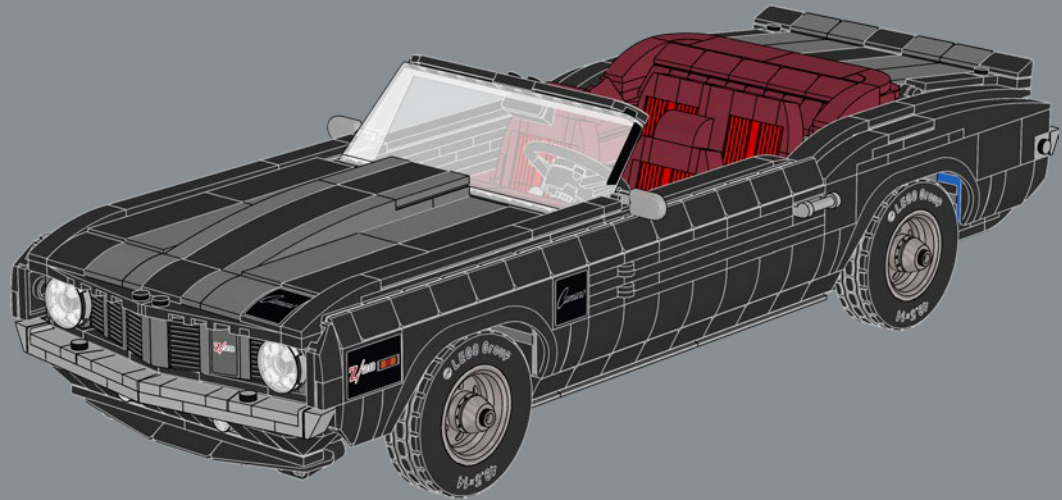
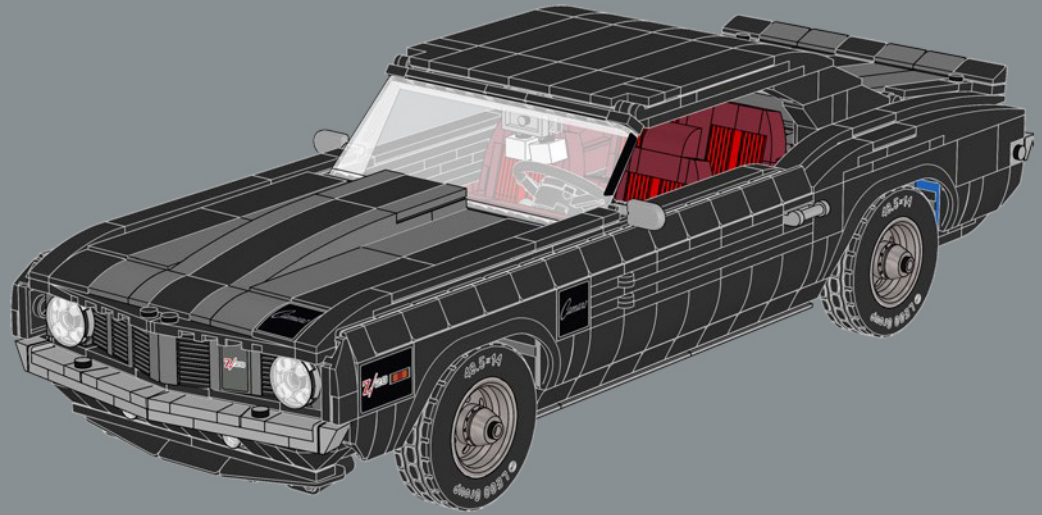

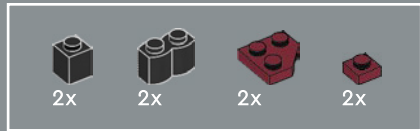
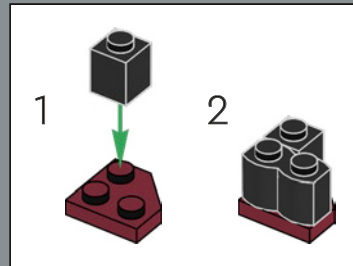

317

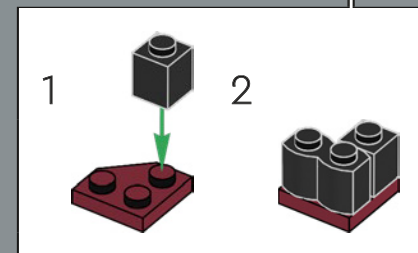
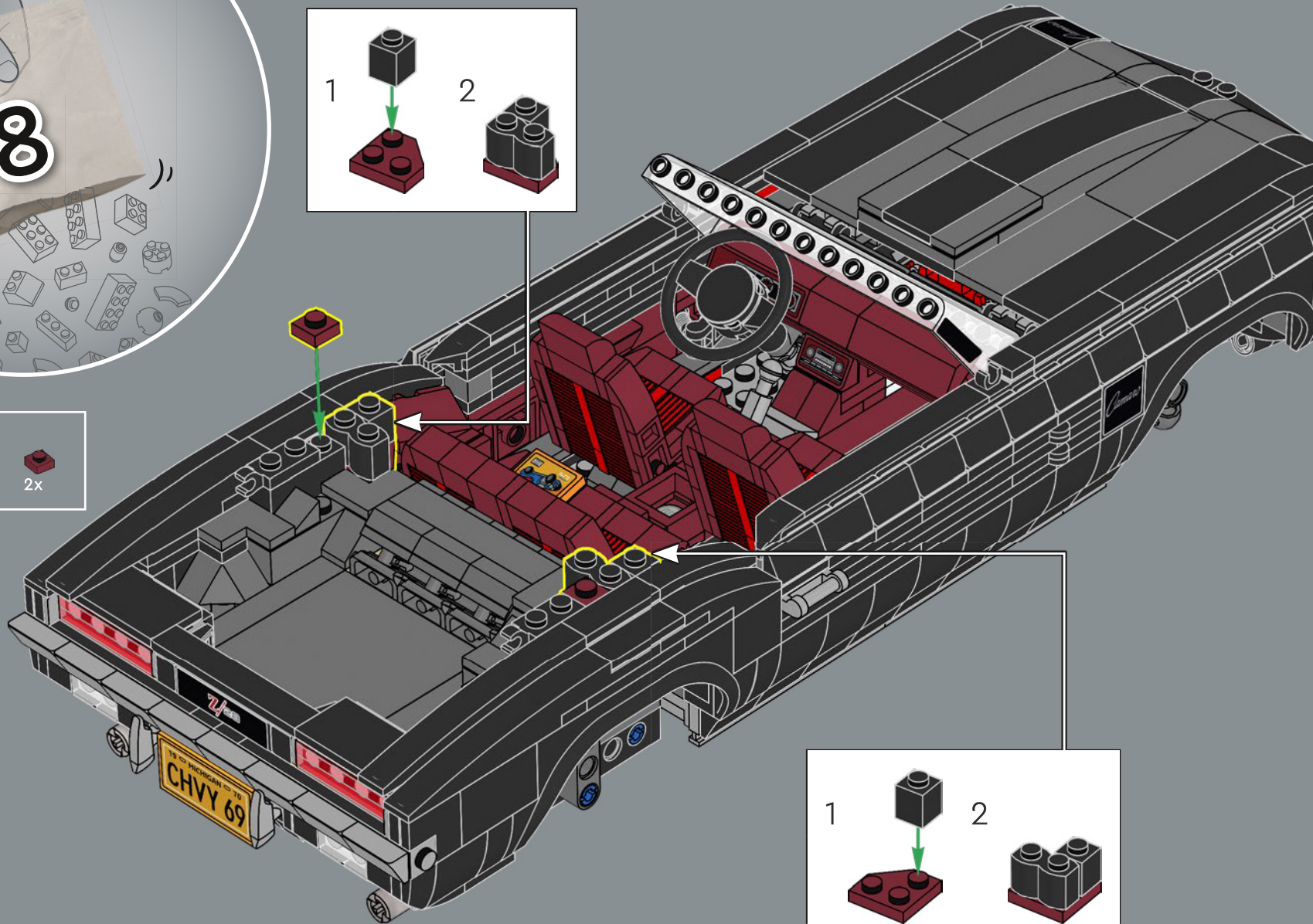

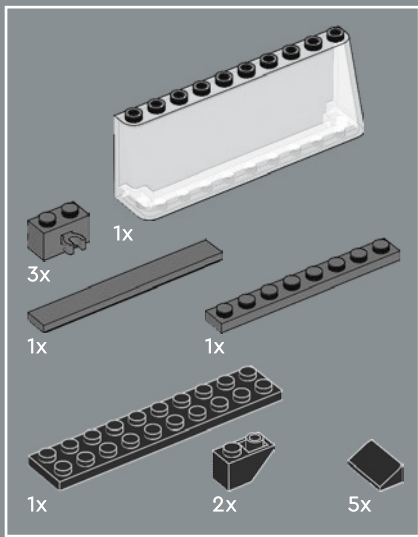

318

1

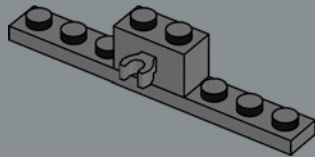

2

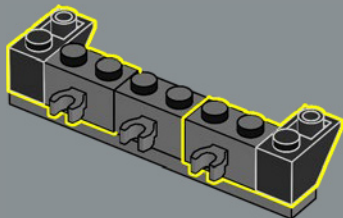

3

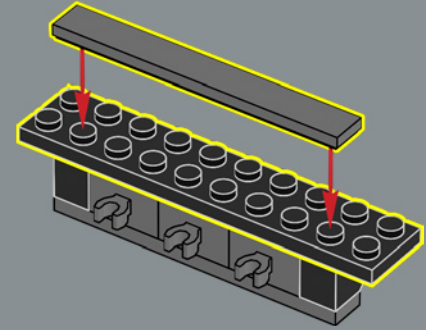

4

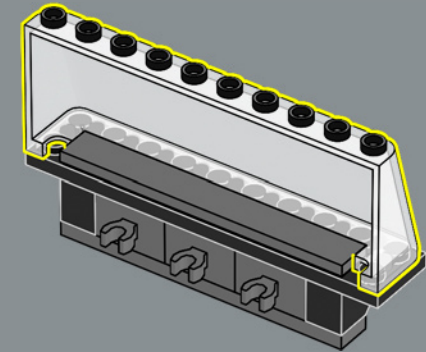

5

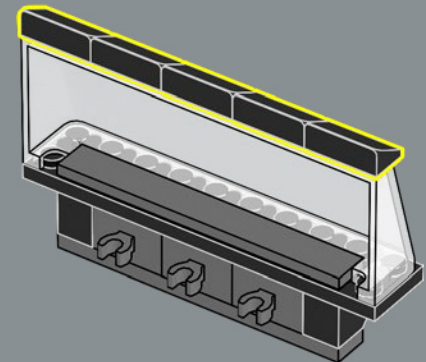

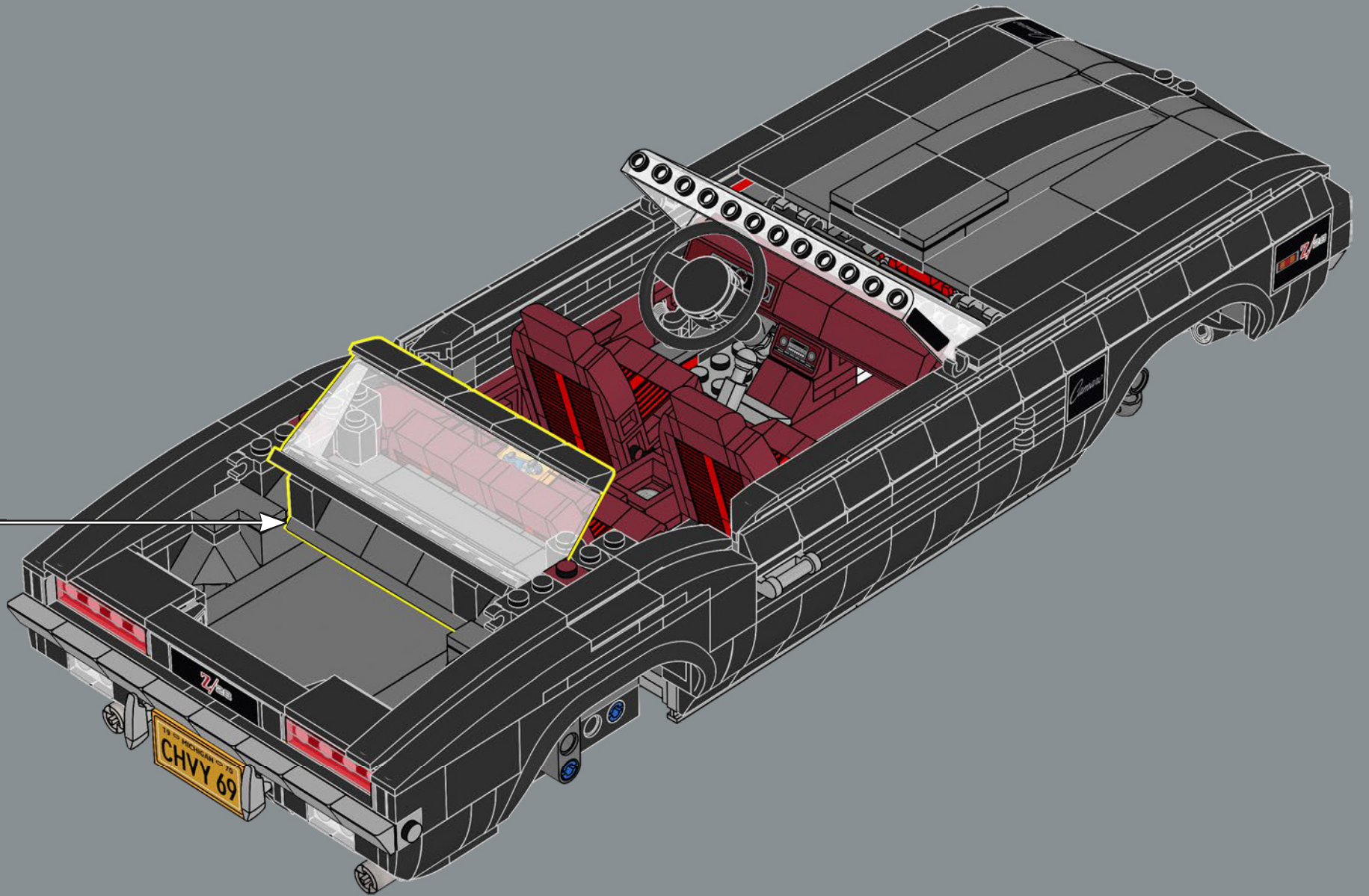

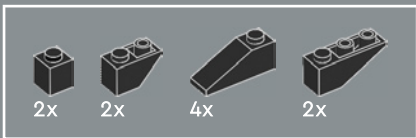

319

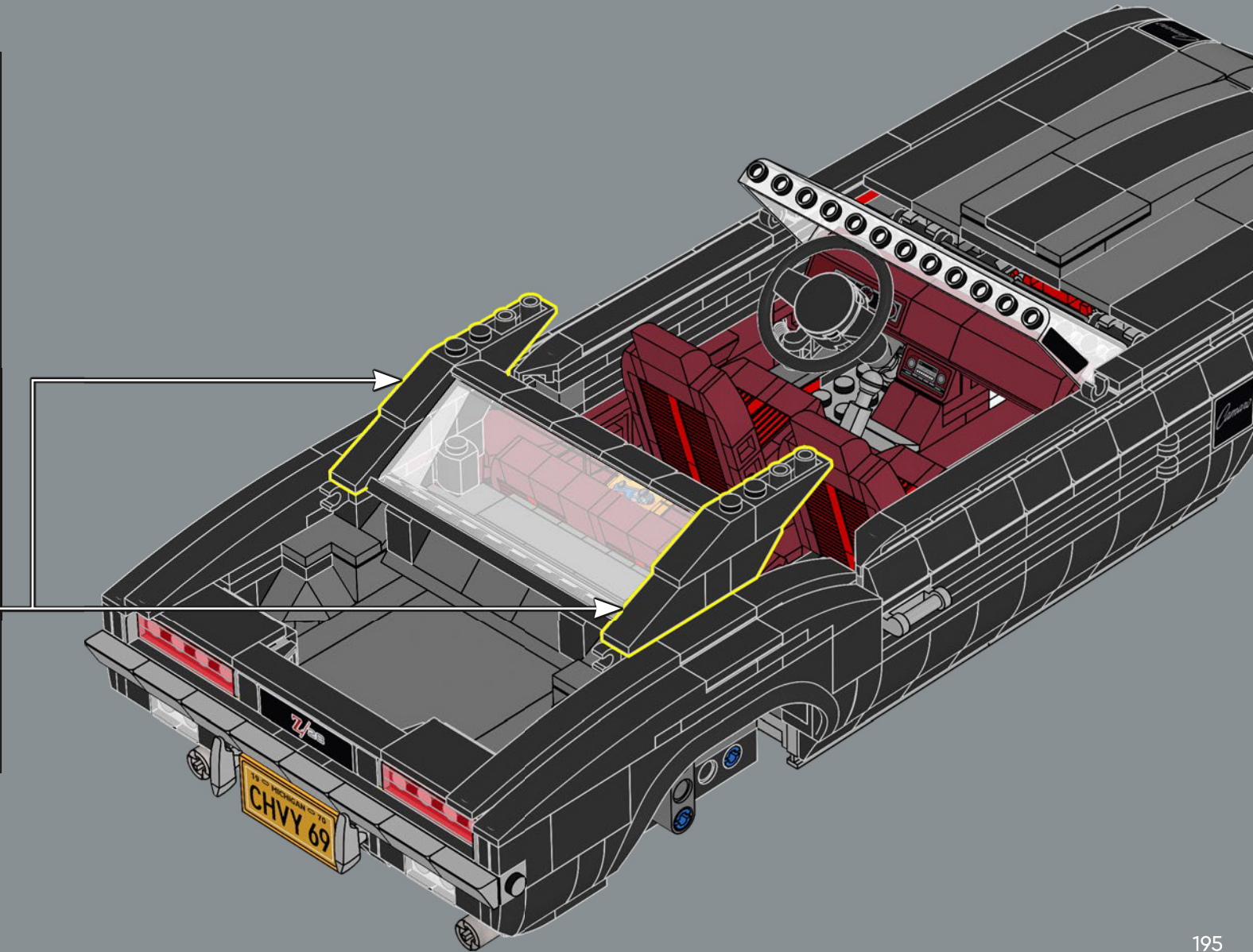
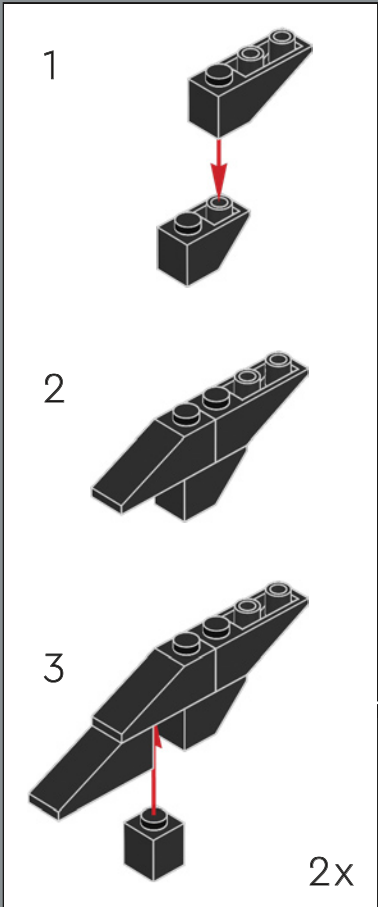

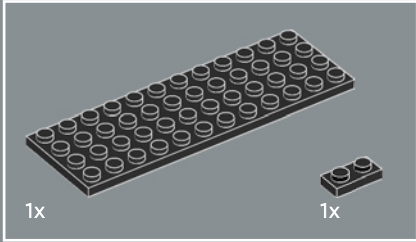
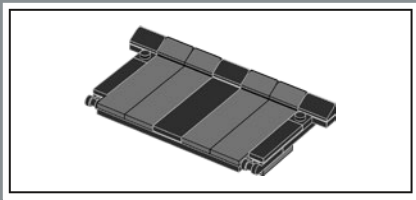

320

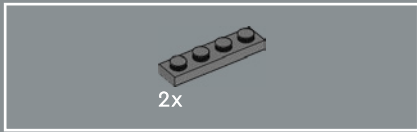
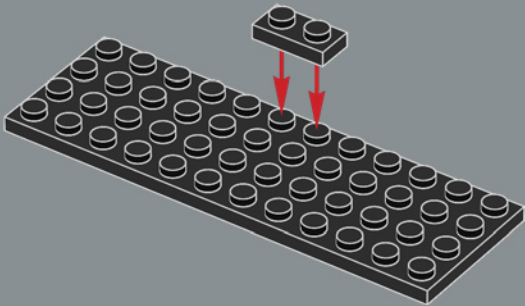

321

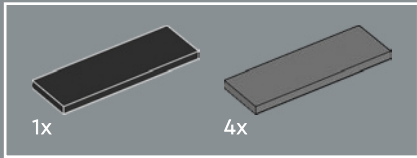
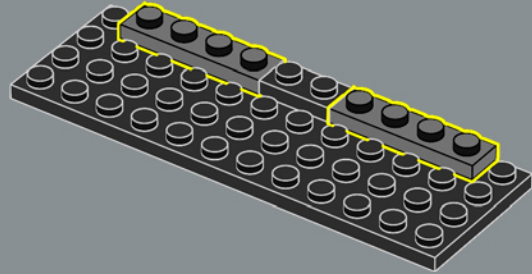

322

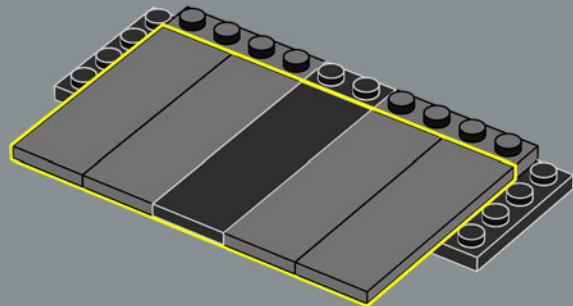

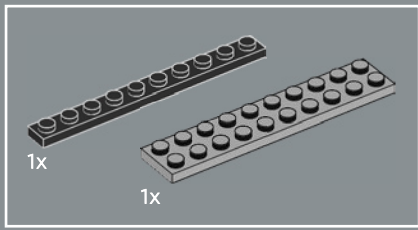

323

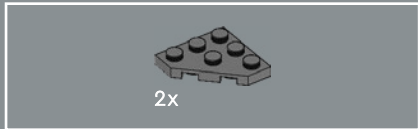
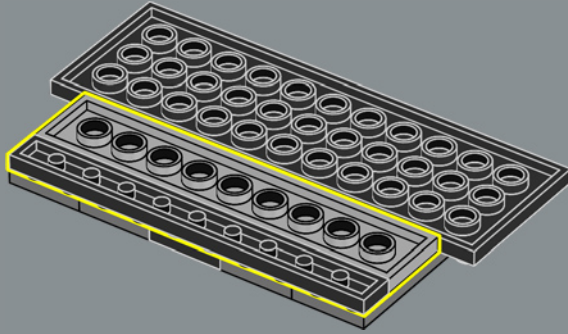

324

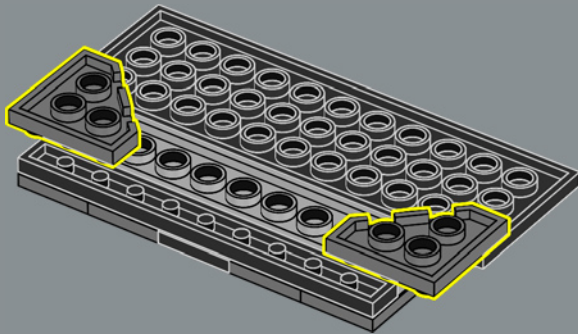

325

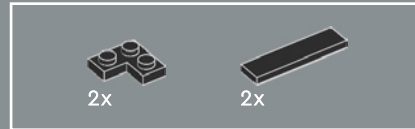
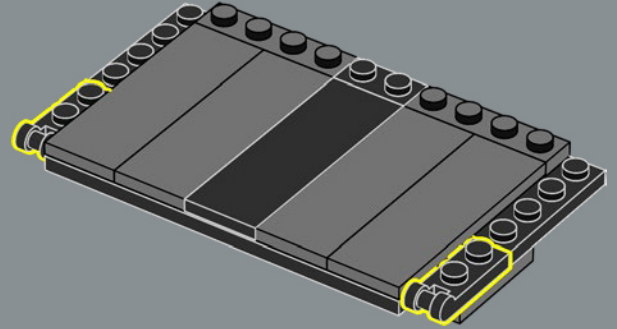

326

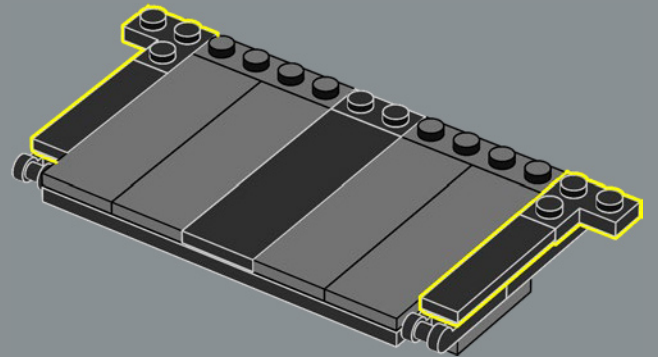

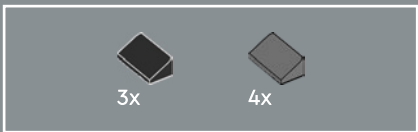

327

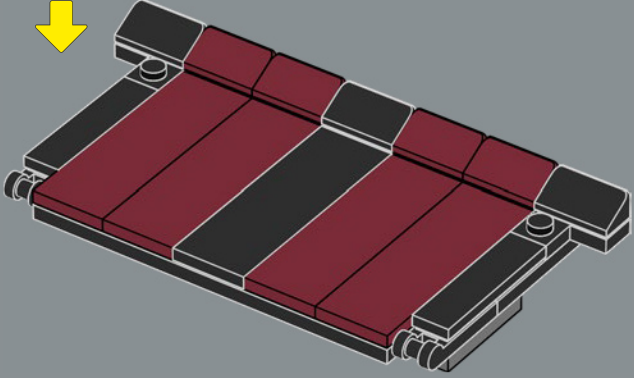
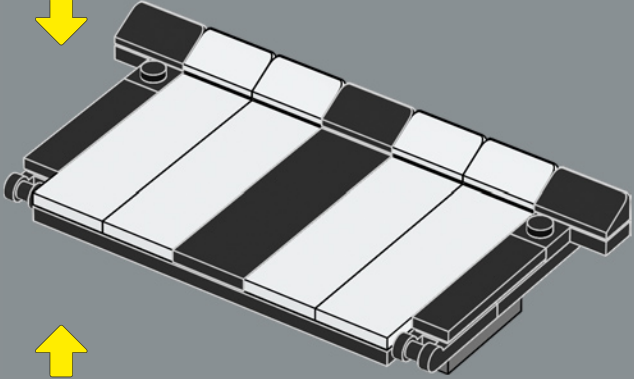
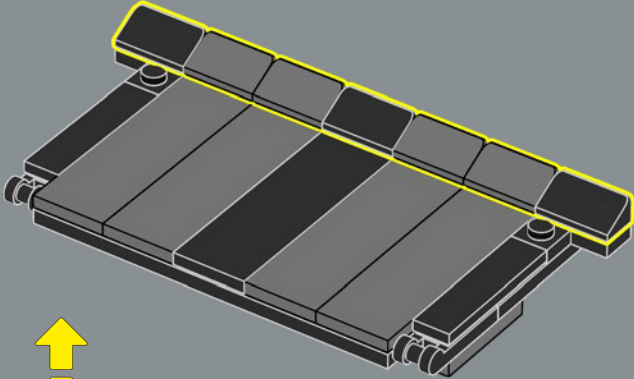

328

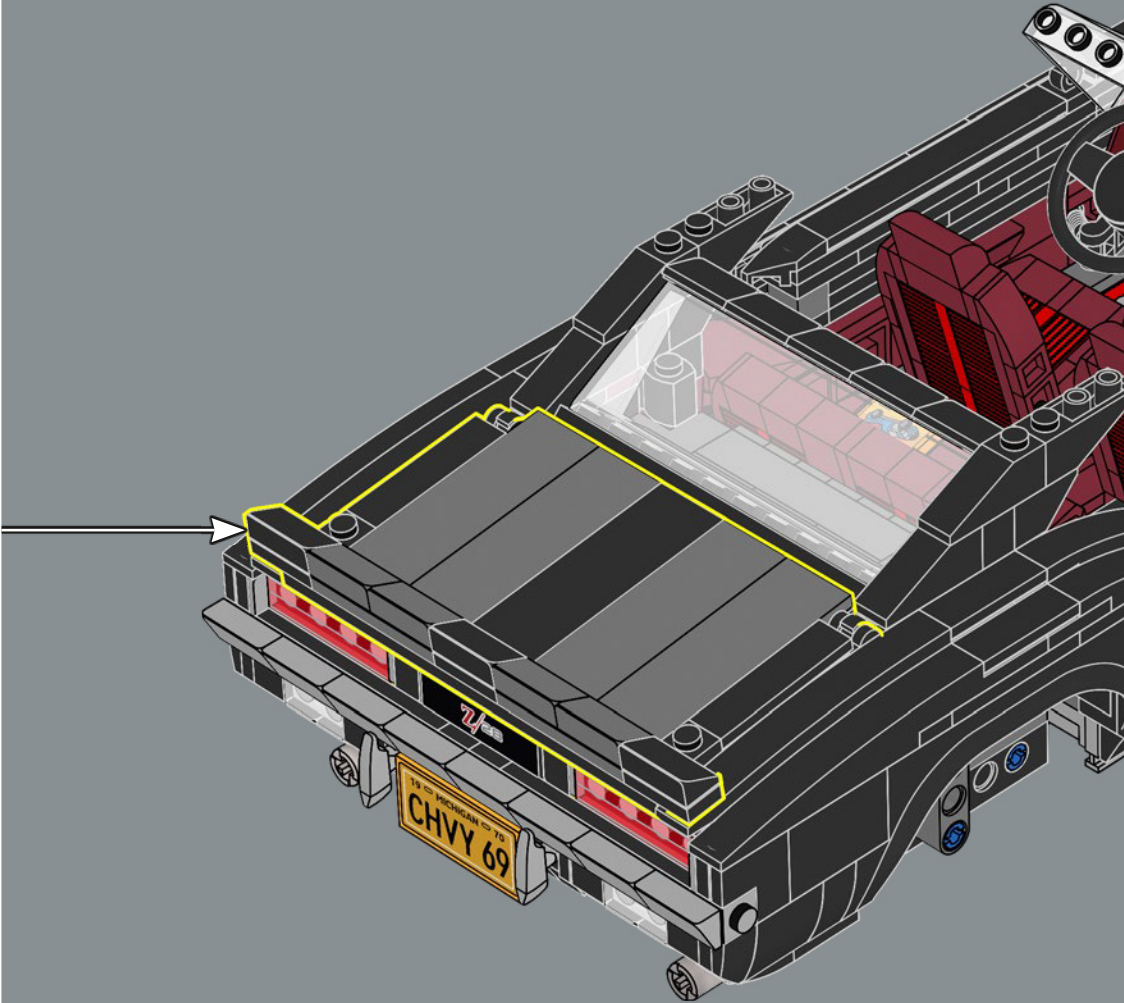

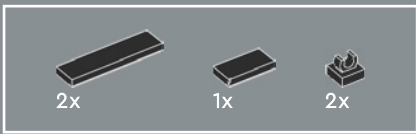

329

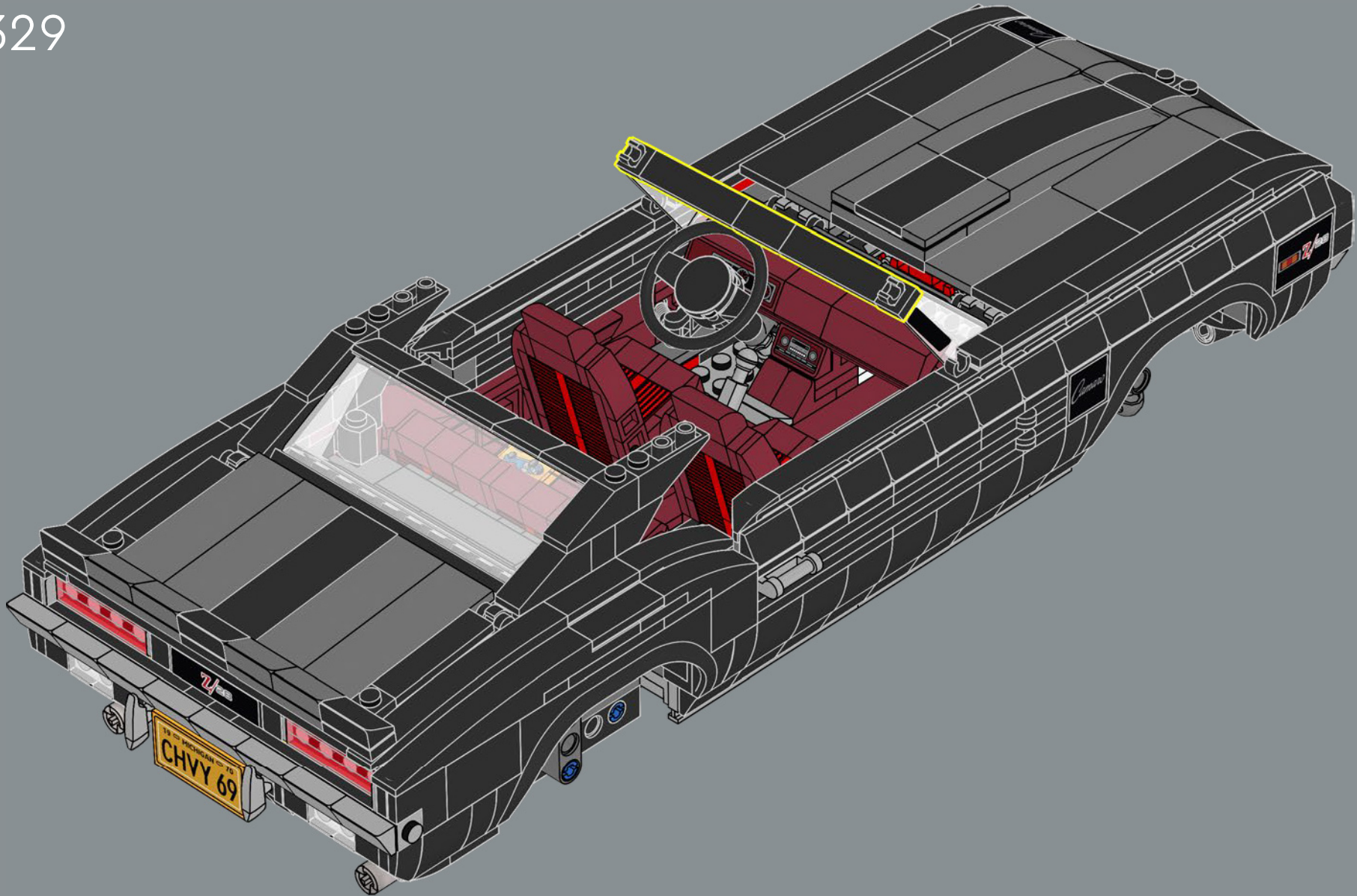

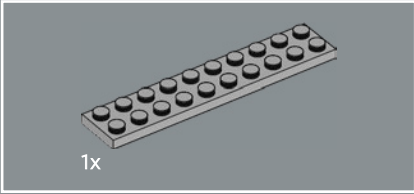
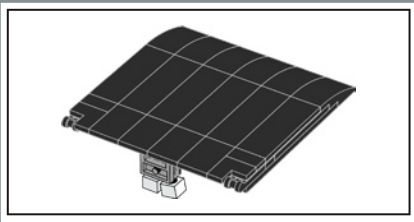

330

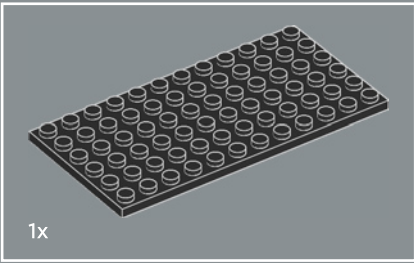
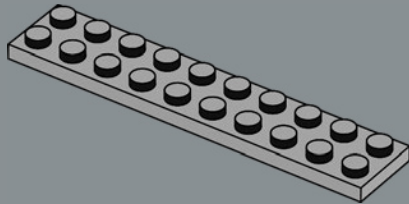

331

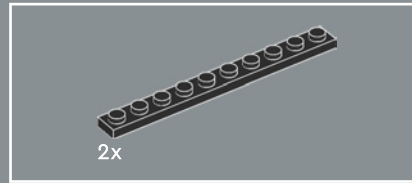
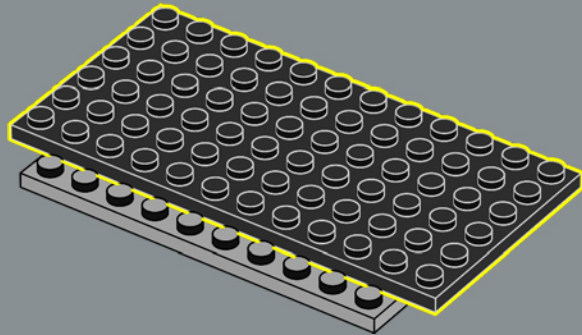

2x

332

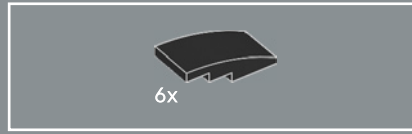
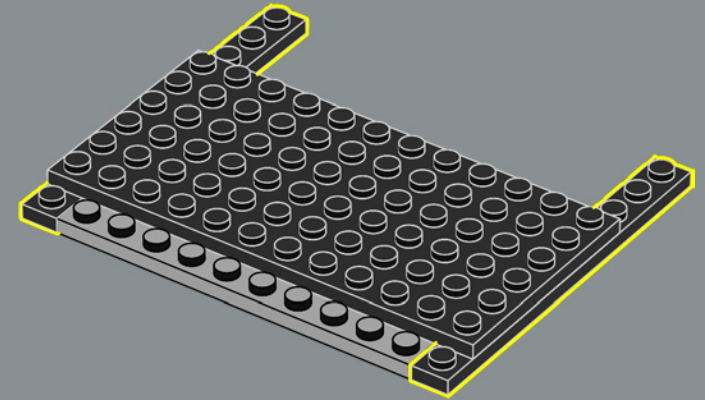

6x

333

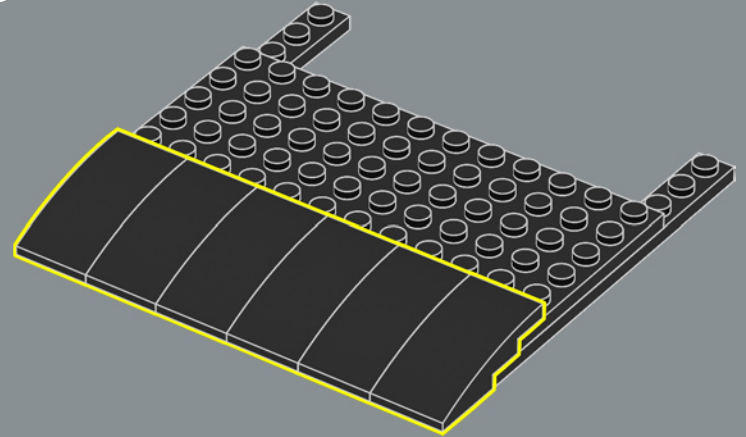

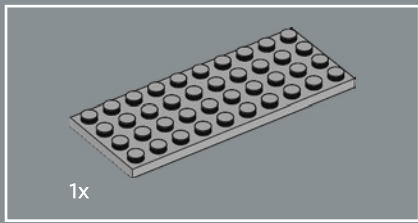

334

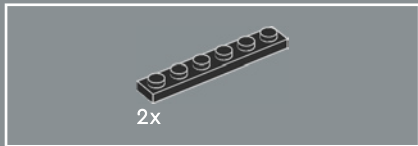
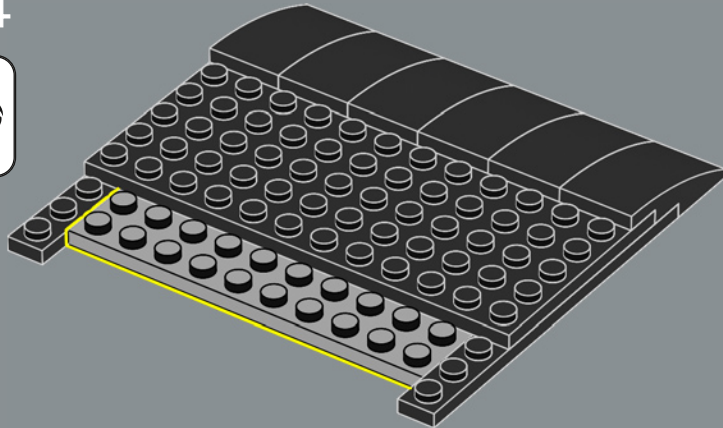

335

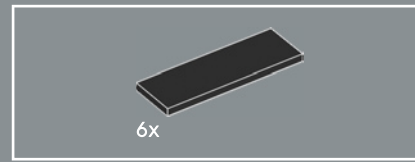
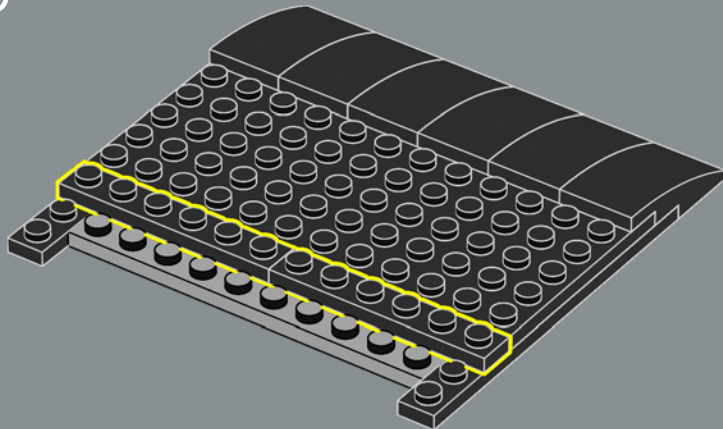

336

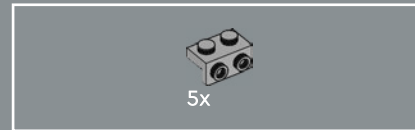
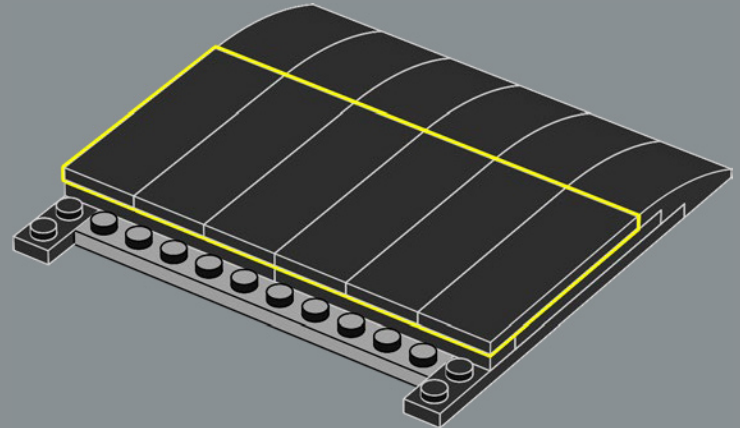

337

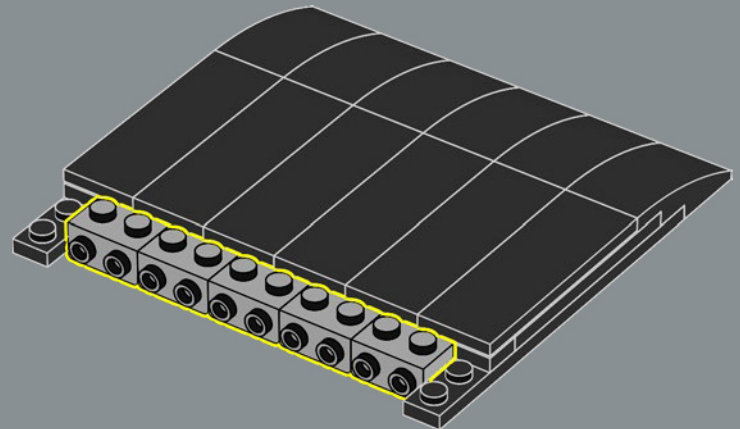

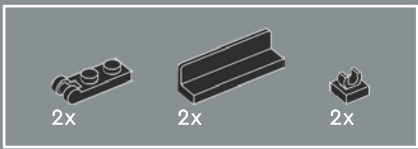

338

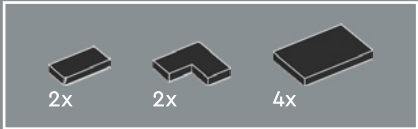
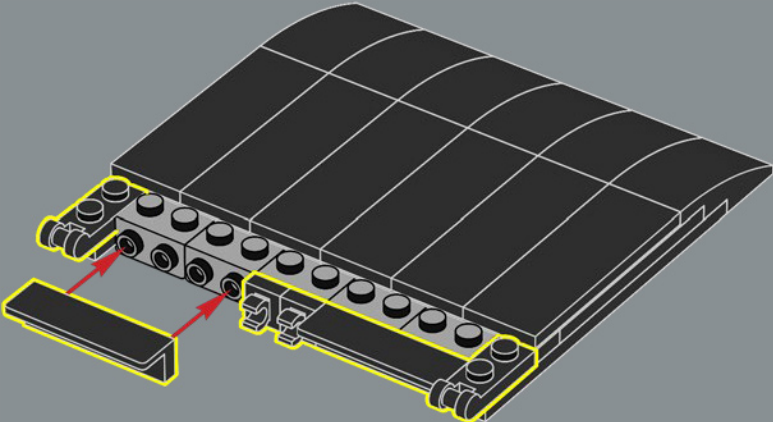

339

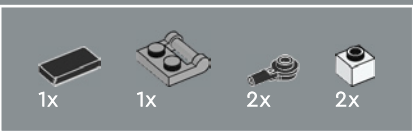
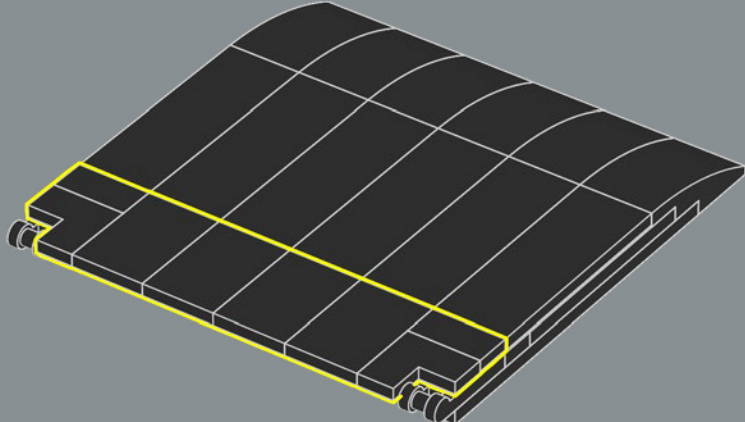

340

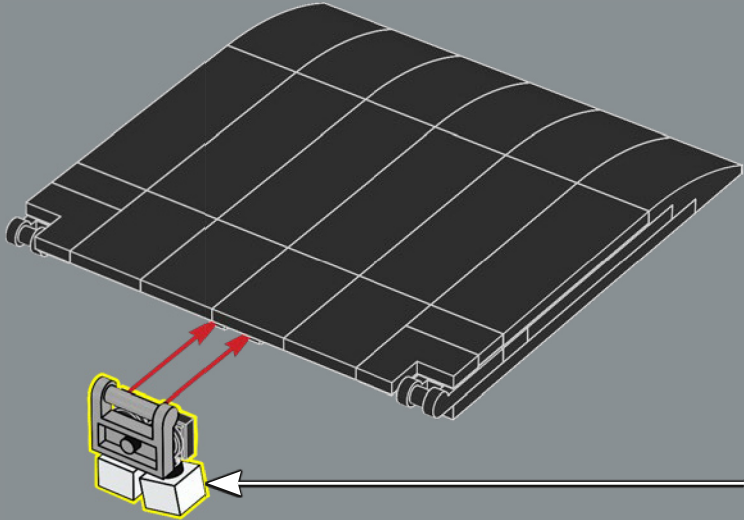
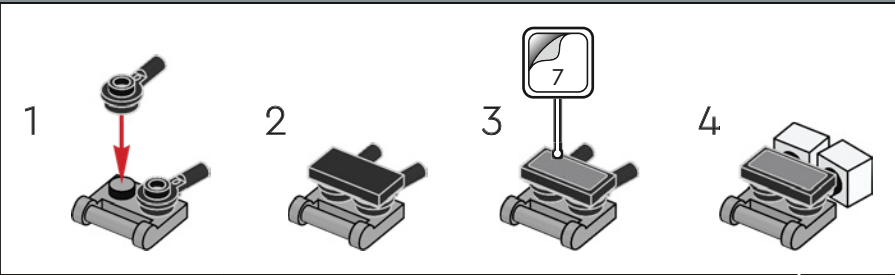

341

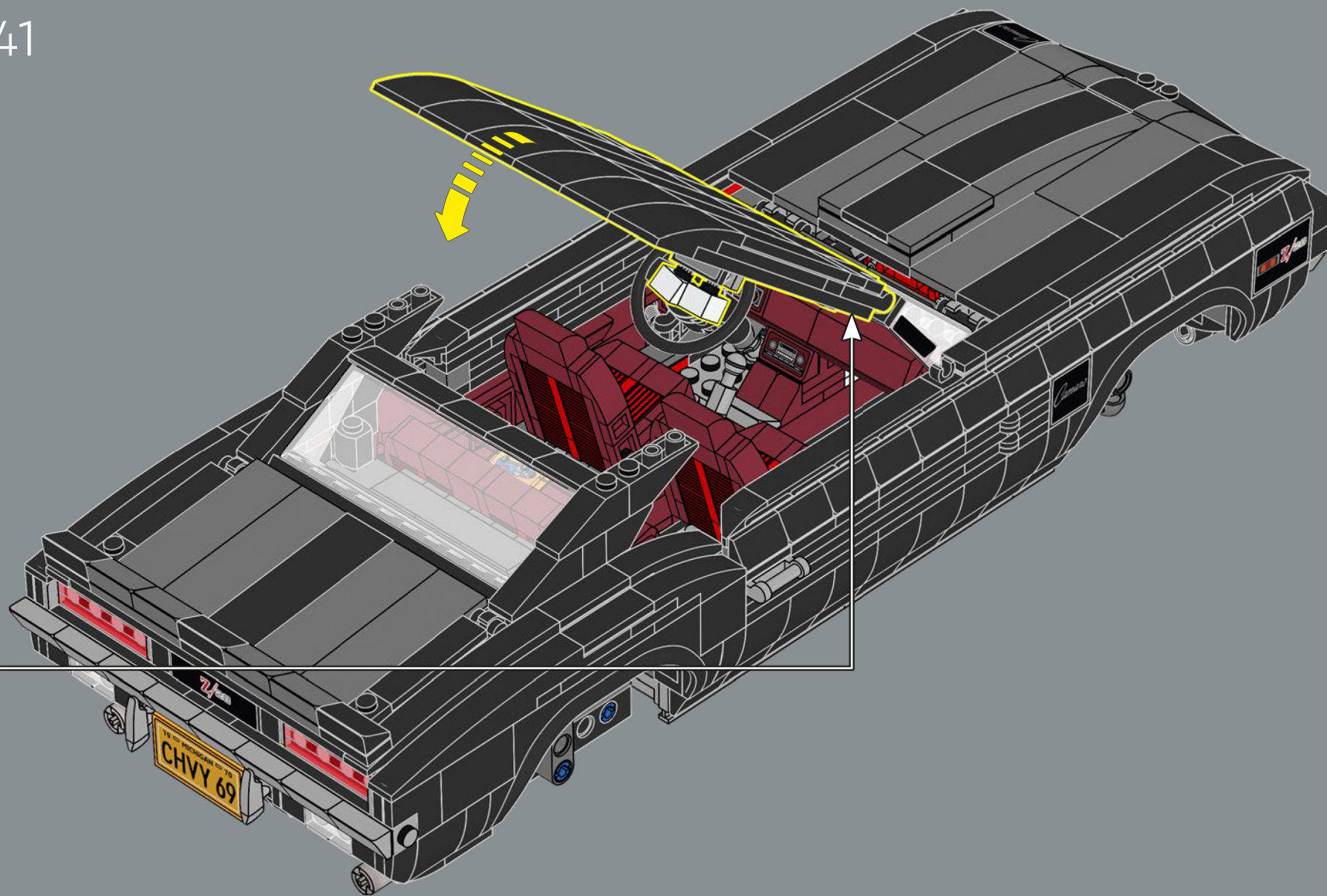

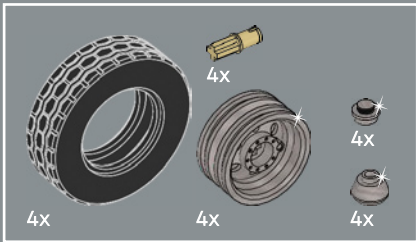
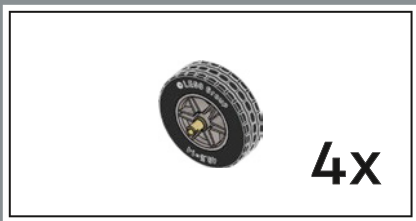

342

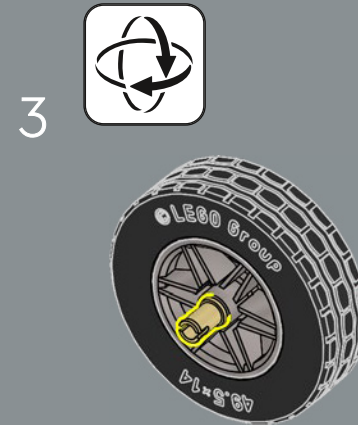
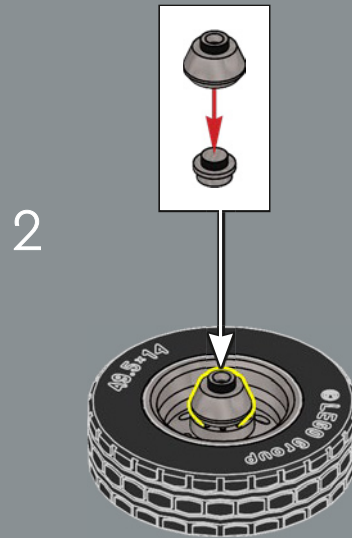
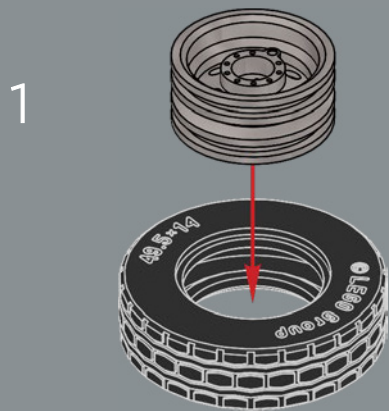

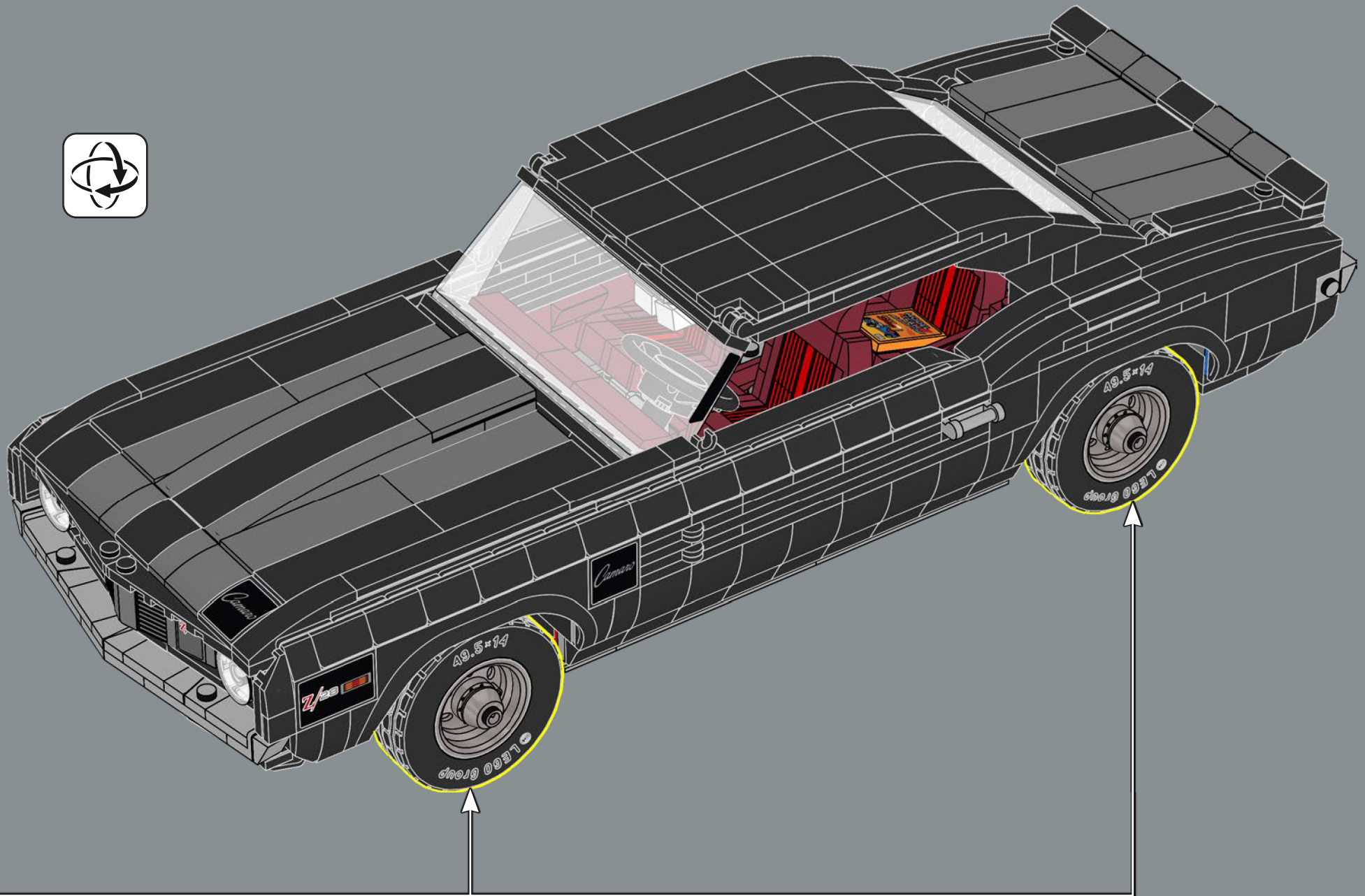



2x

343

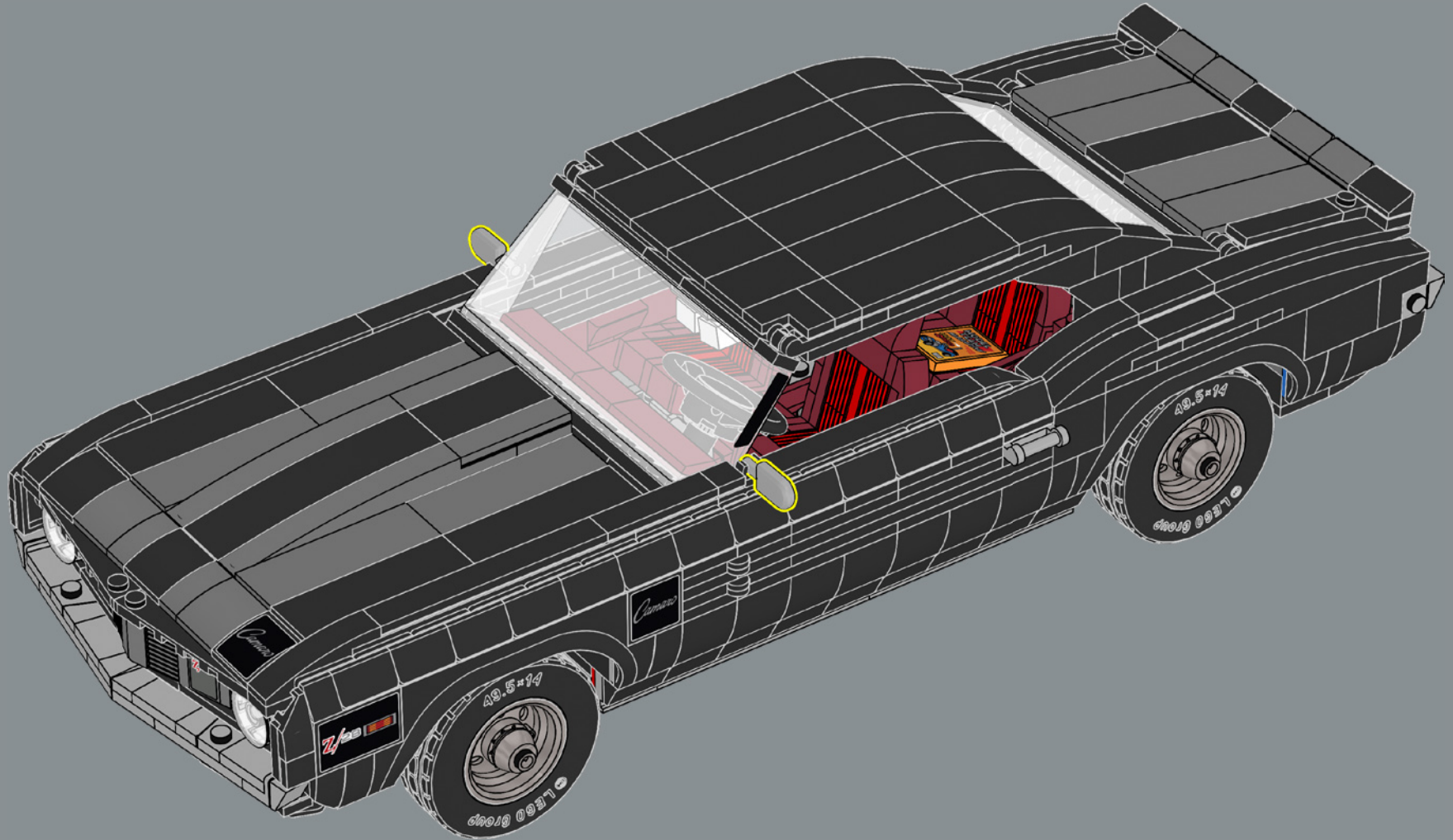

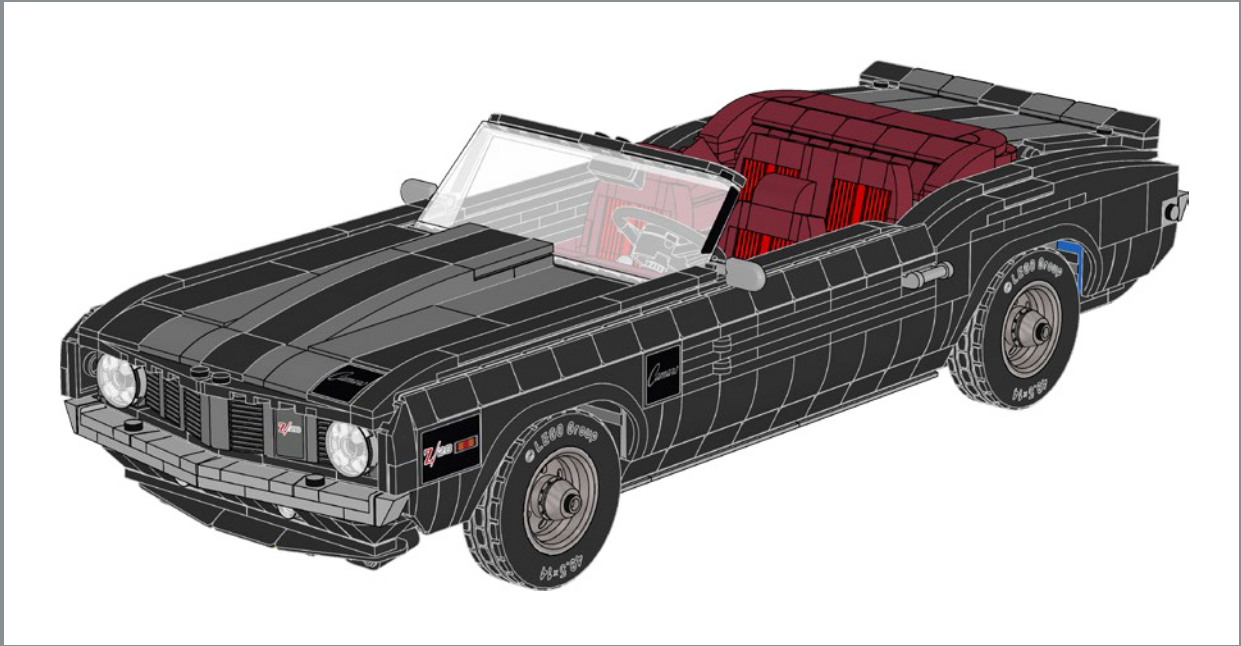

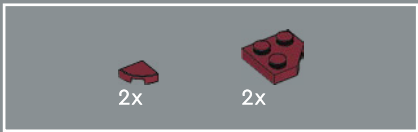

317

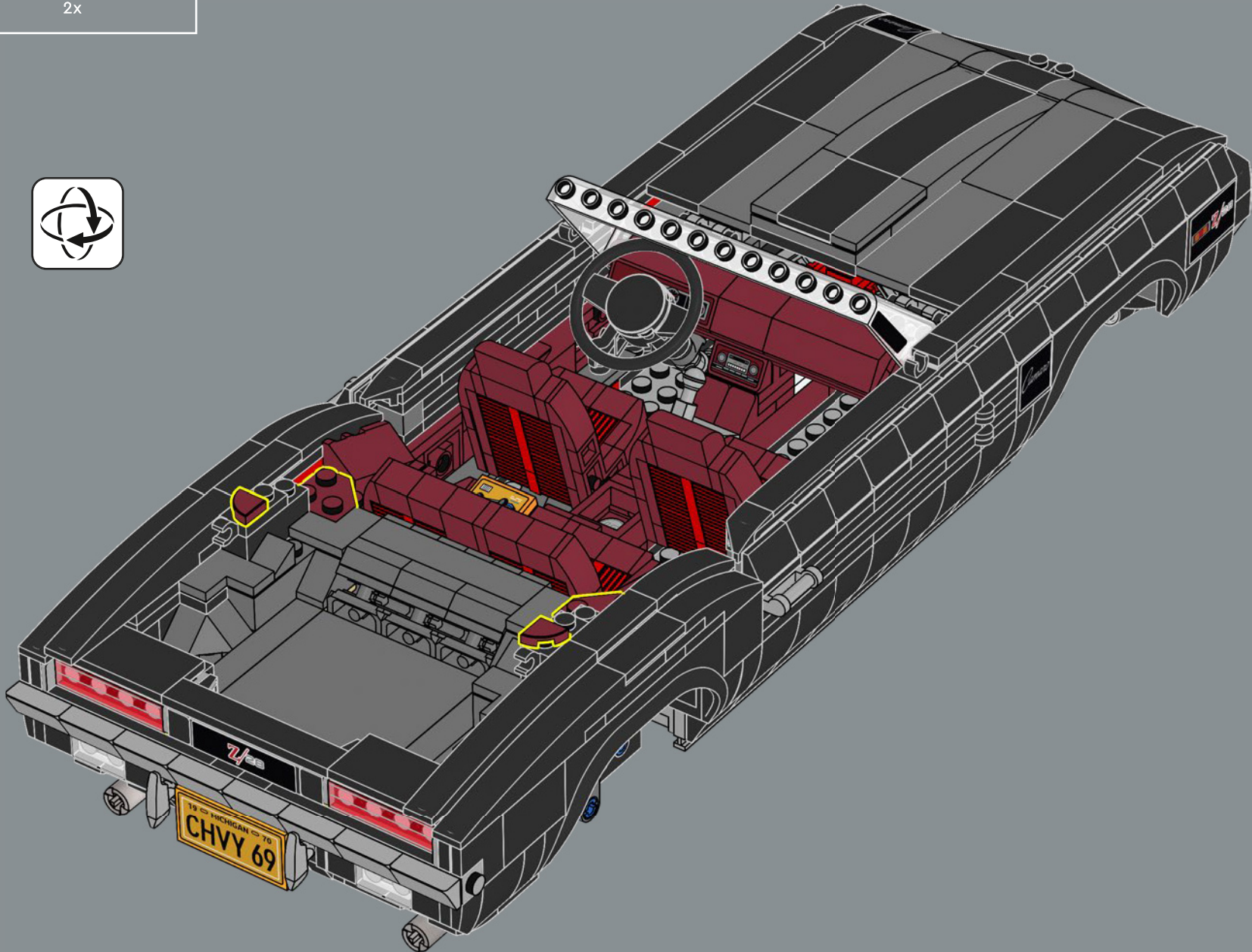

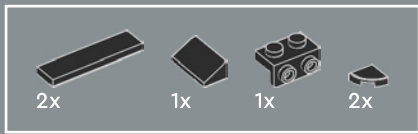

318

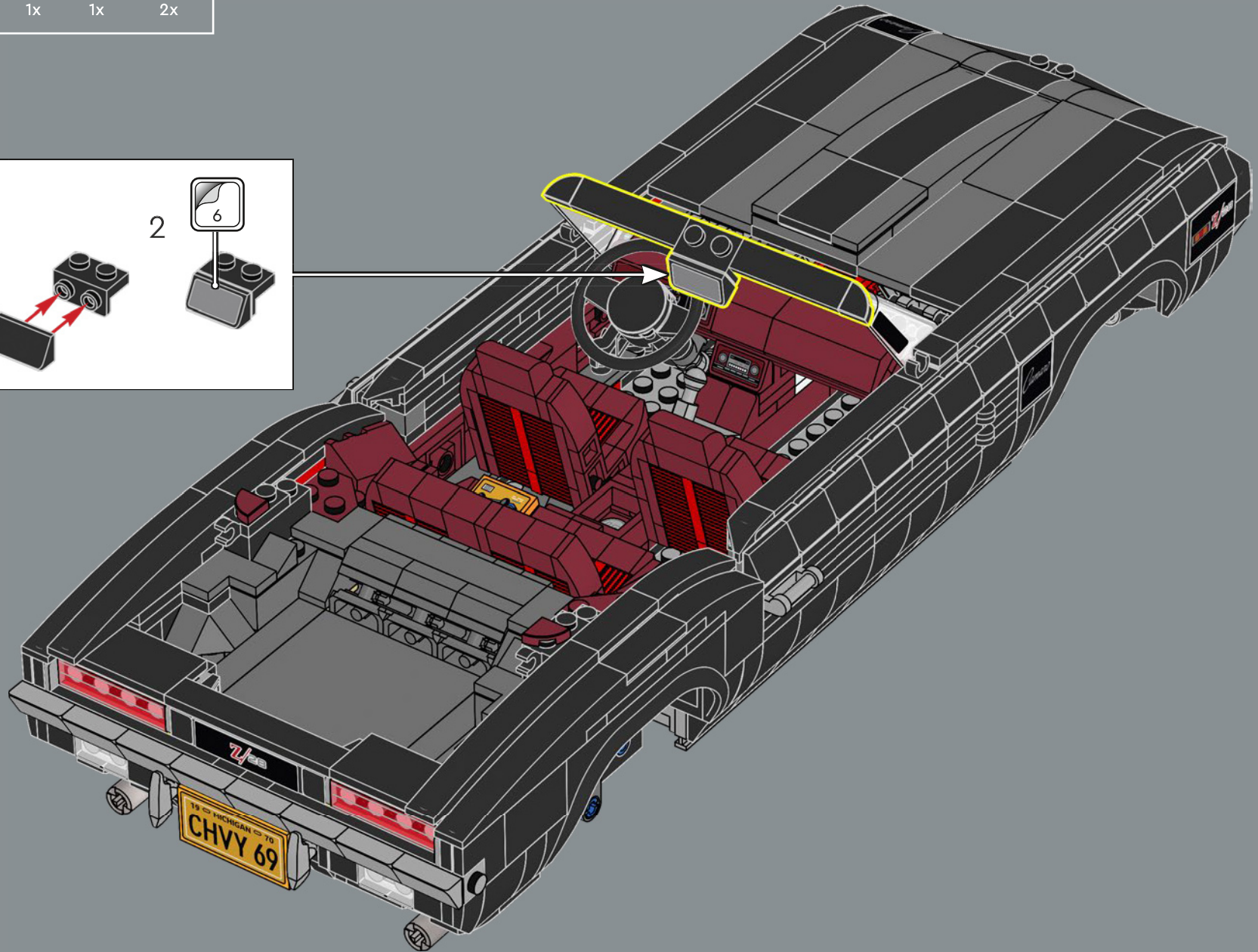
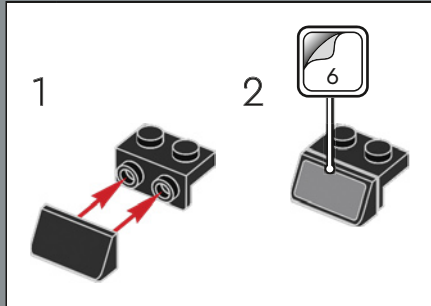

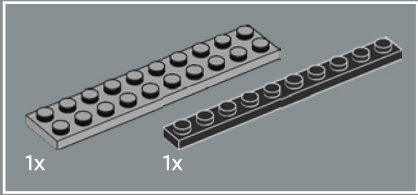

319

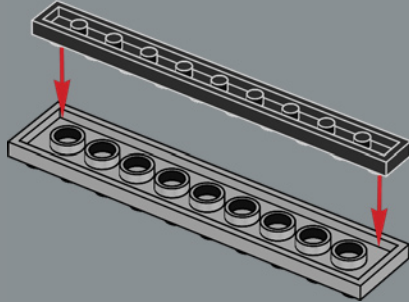

10x

320

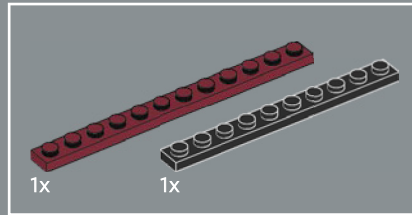
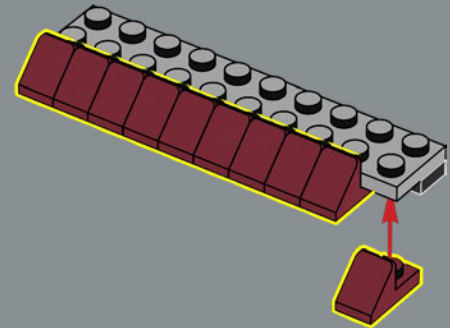

321

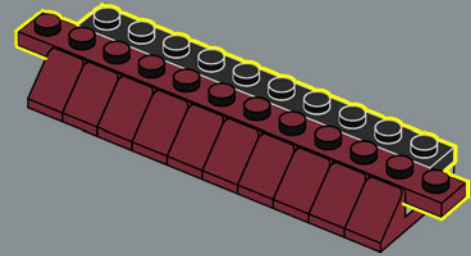

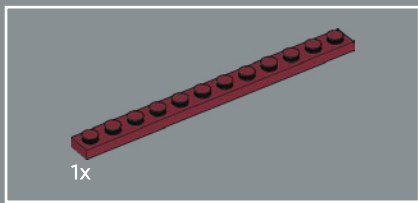

322

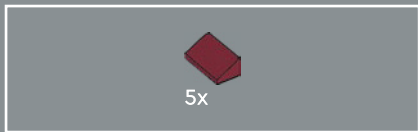
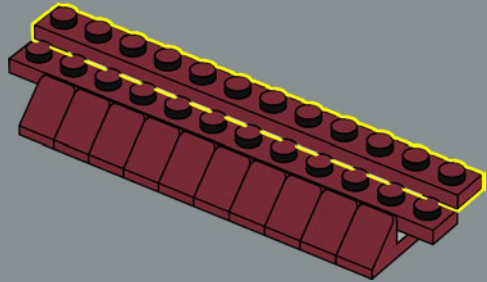

323

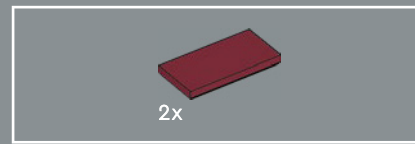
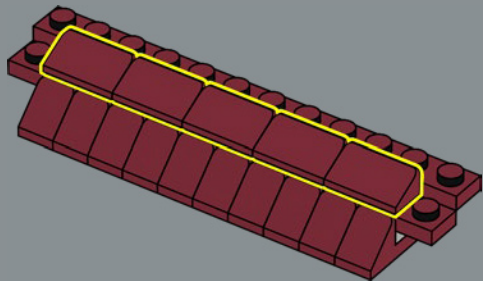

324

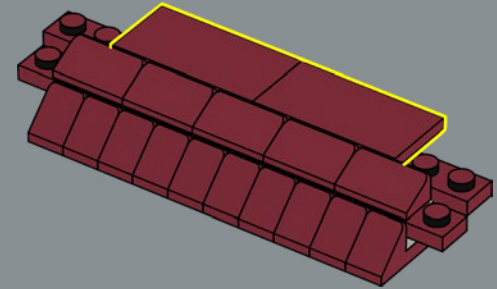

325

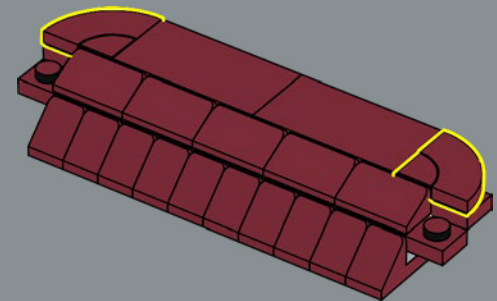

326

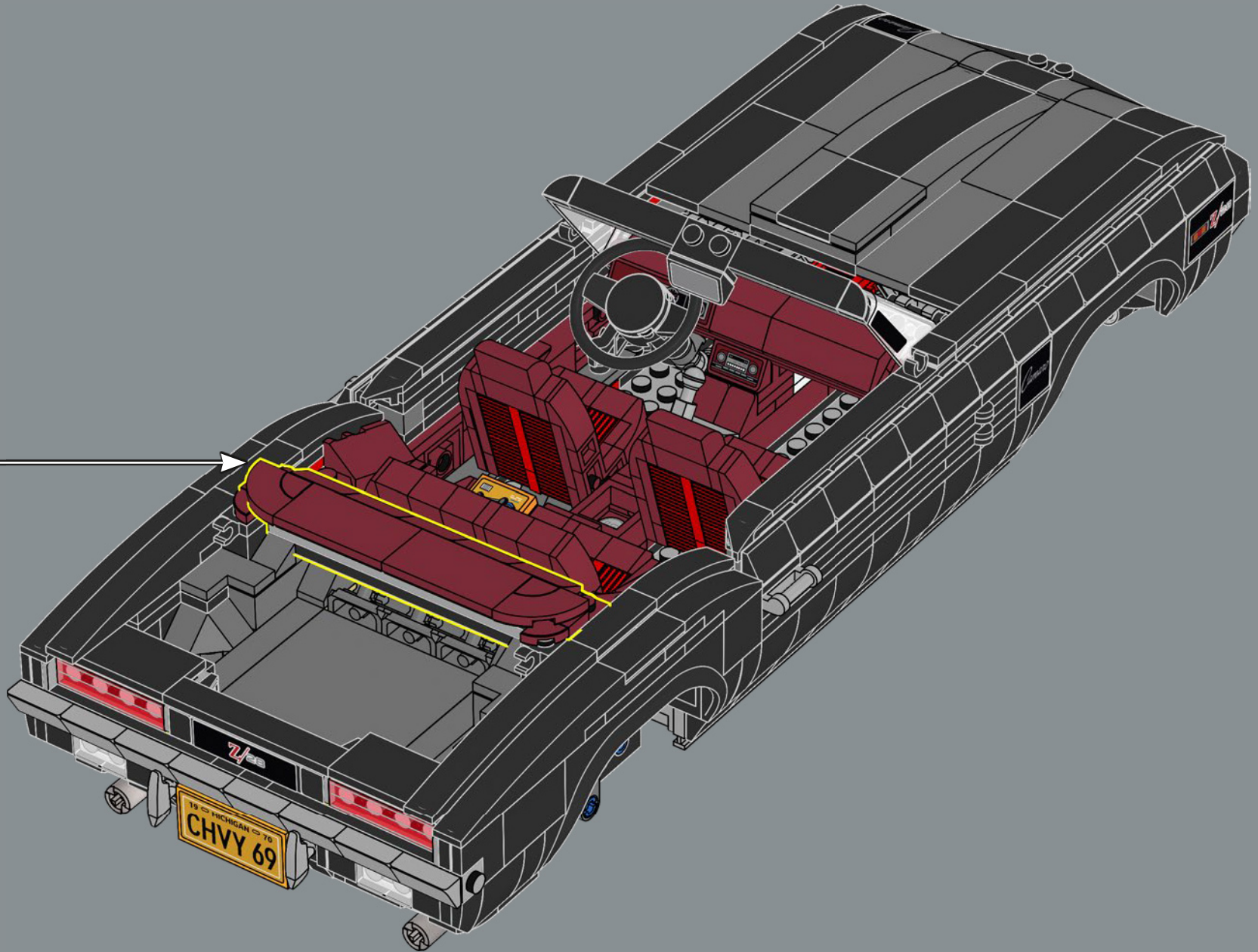

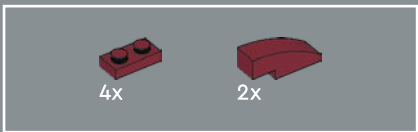

327

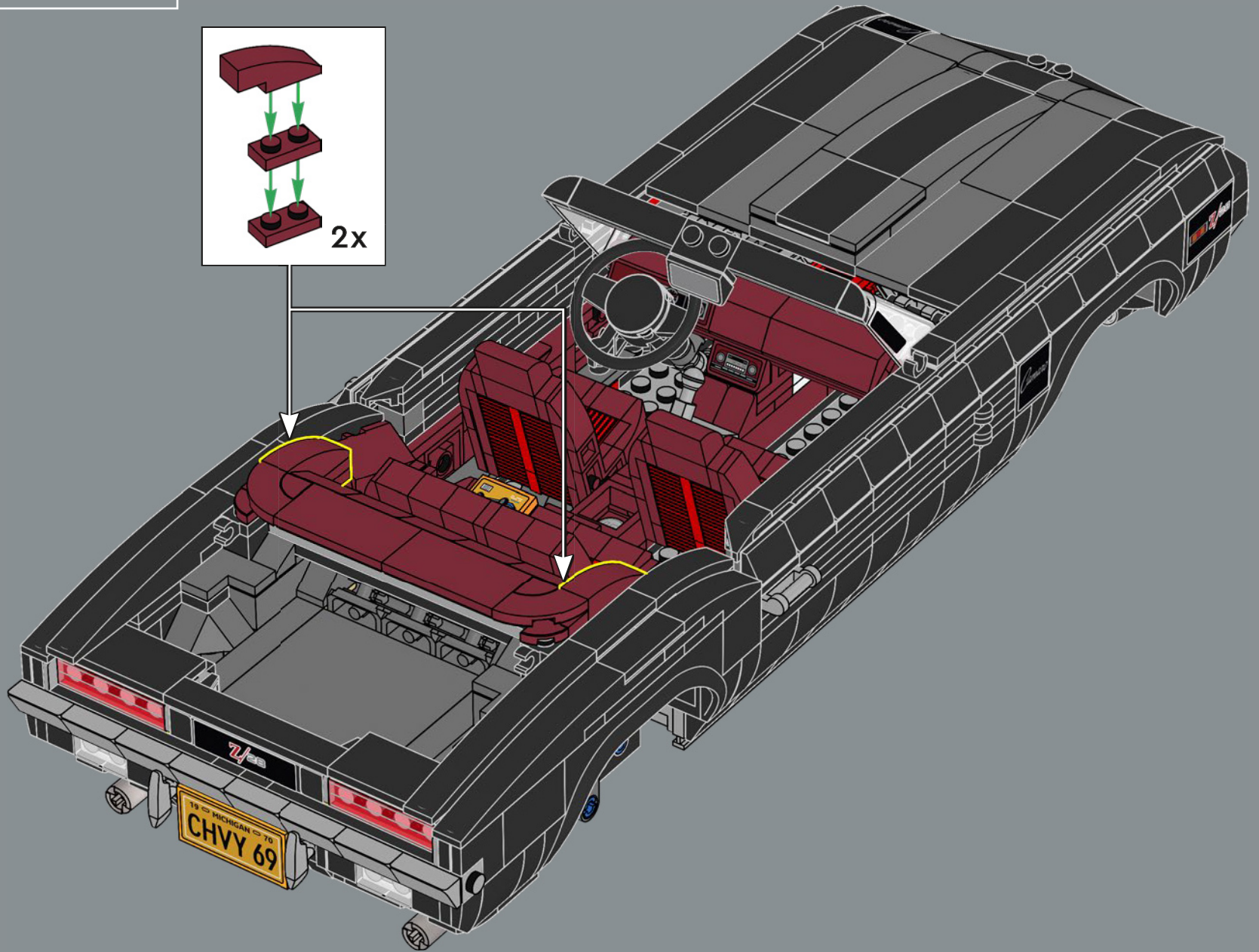
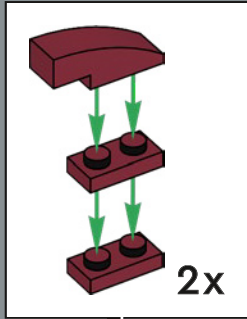

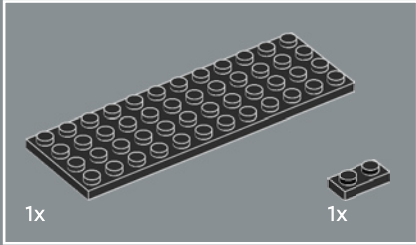
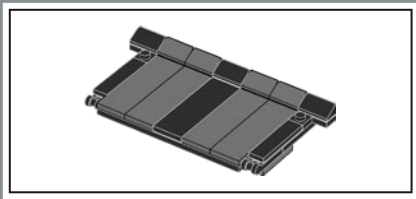

328

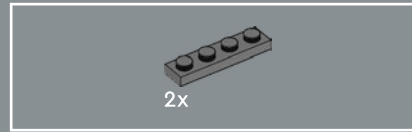
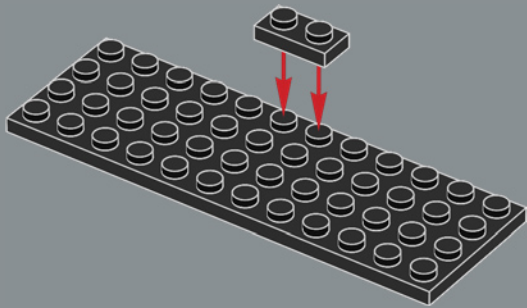

329

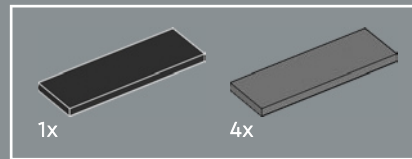
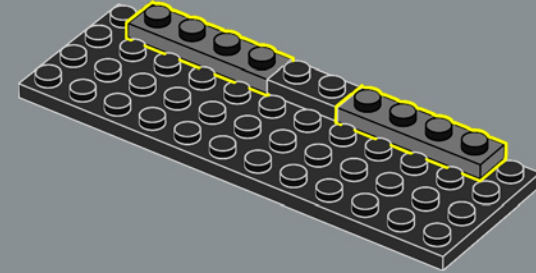

330

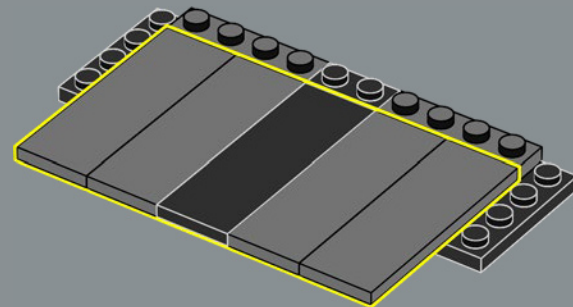

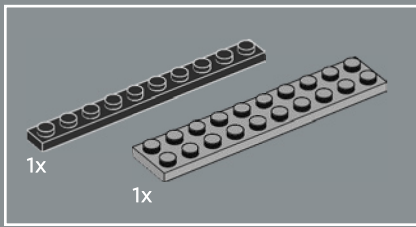

331

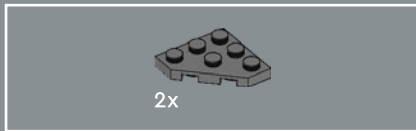
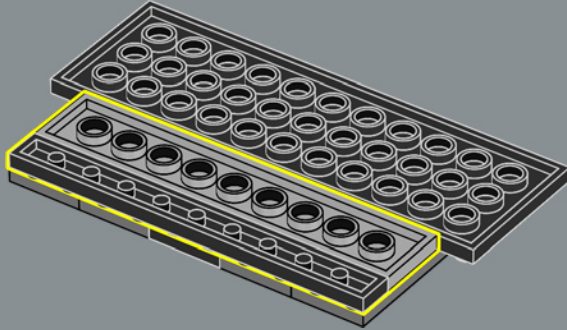

332

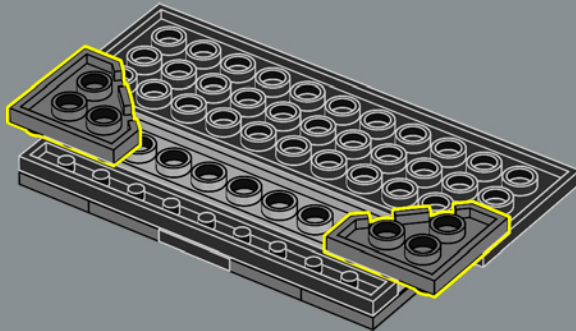

333

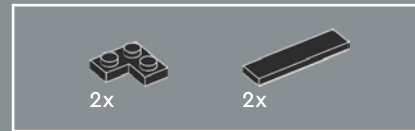
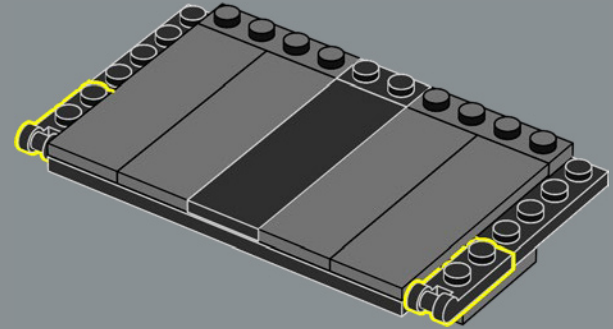

334

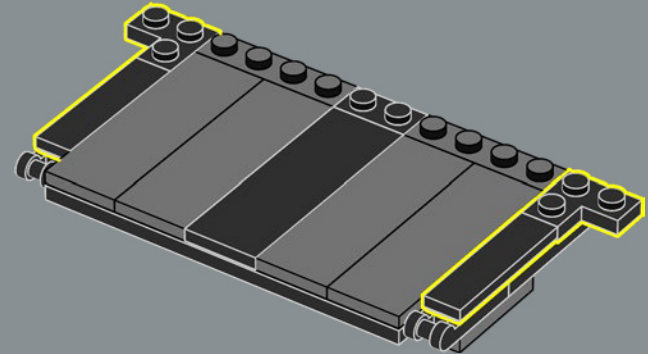



335

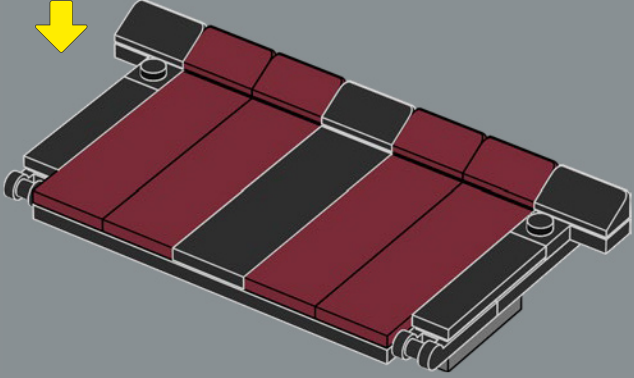
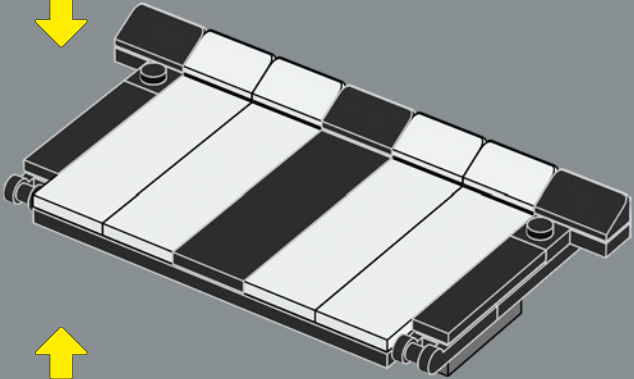
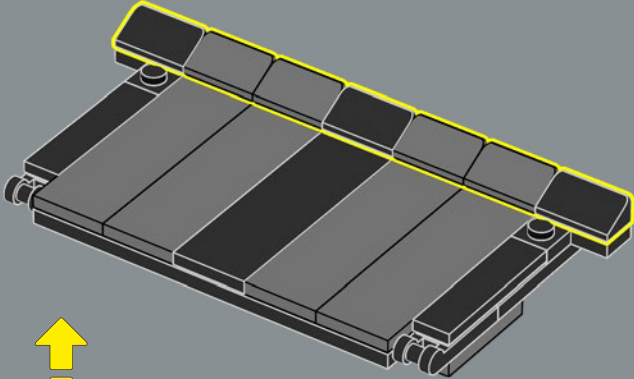

336

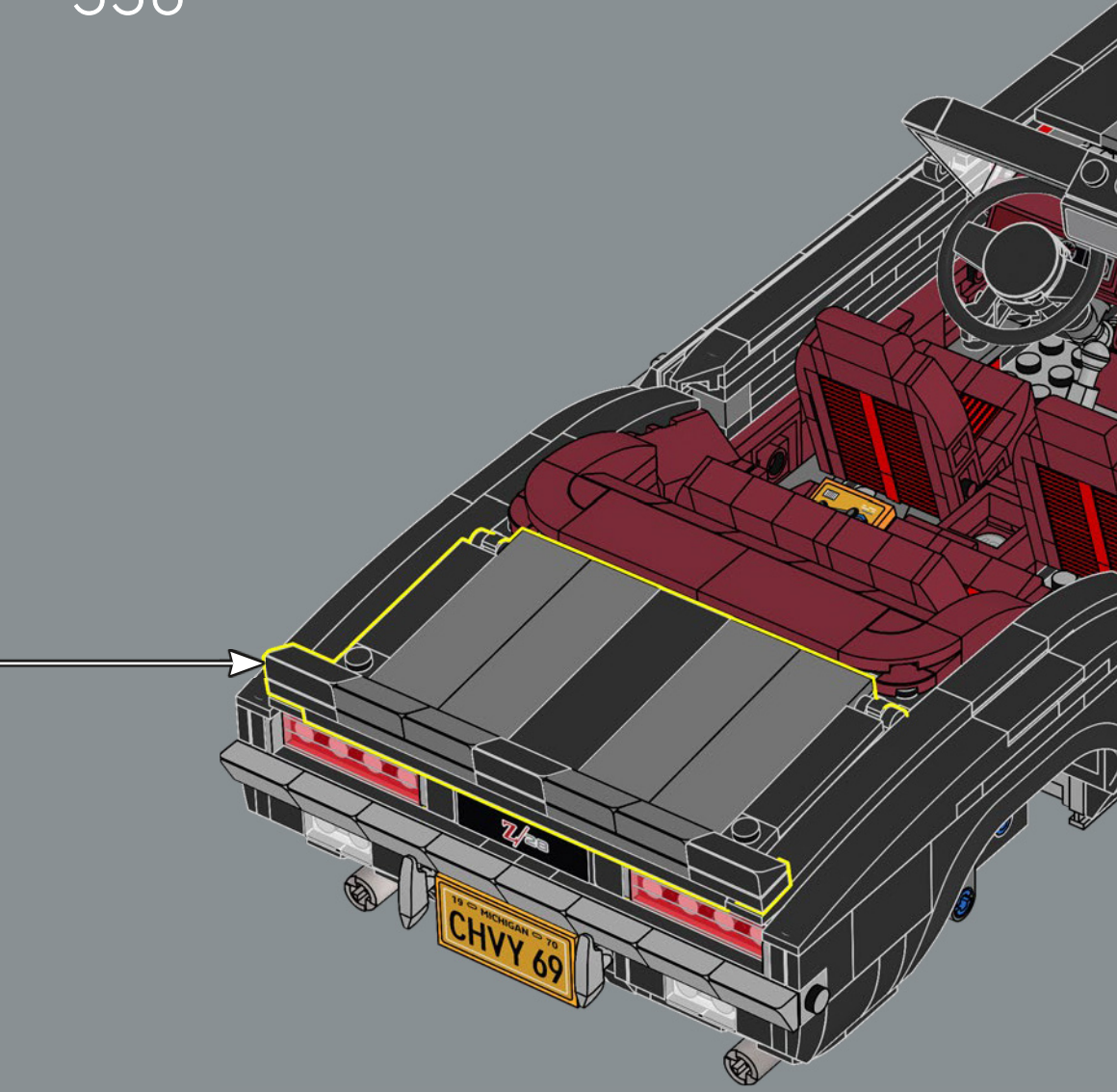

Una riproduzione limitata della pace
car Camaro Z11 della 500 Miglia di
Indianapolis del 1969 rimane uno dei
modelli Camaro più ricercati.

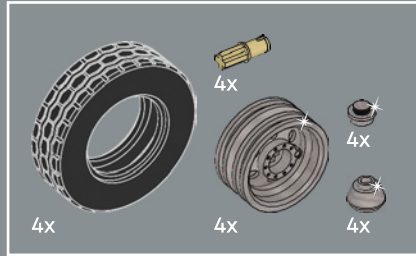
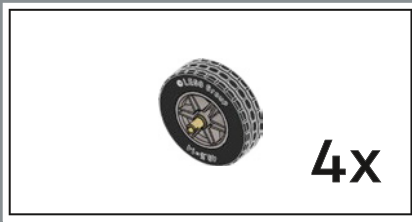

337

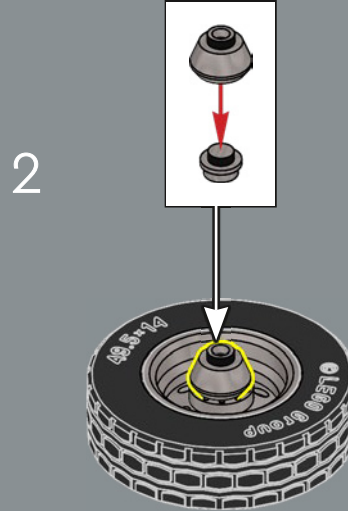
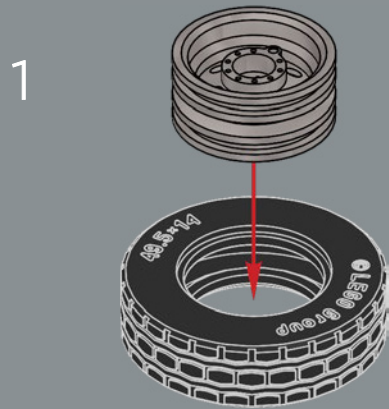

4x

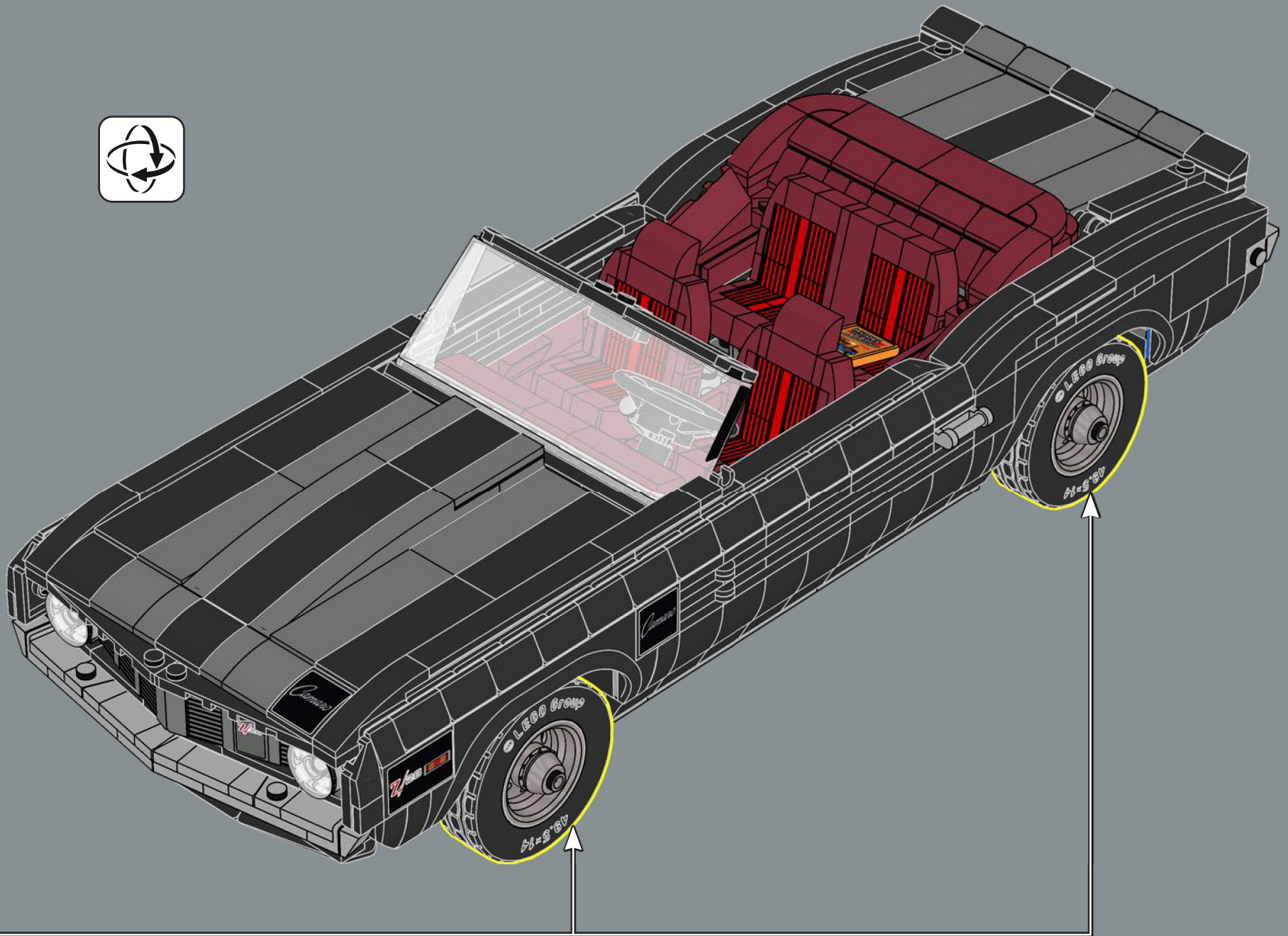



338

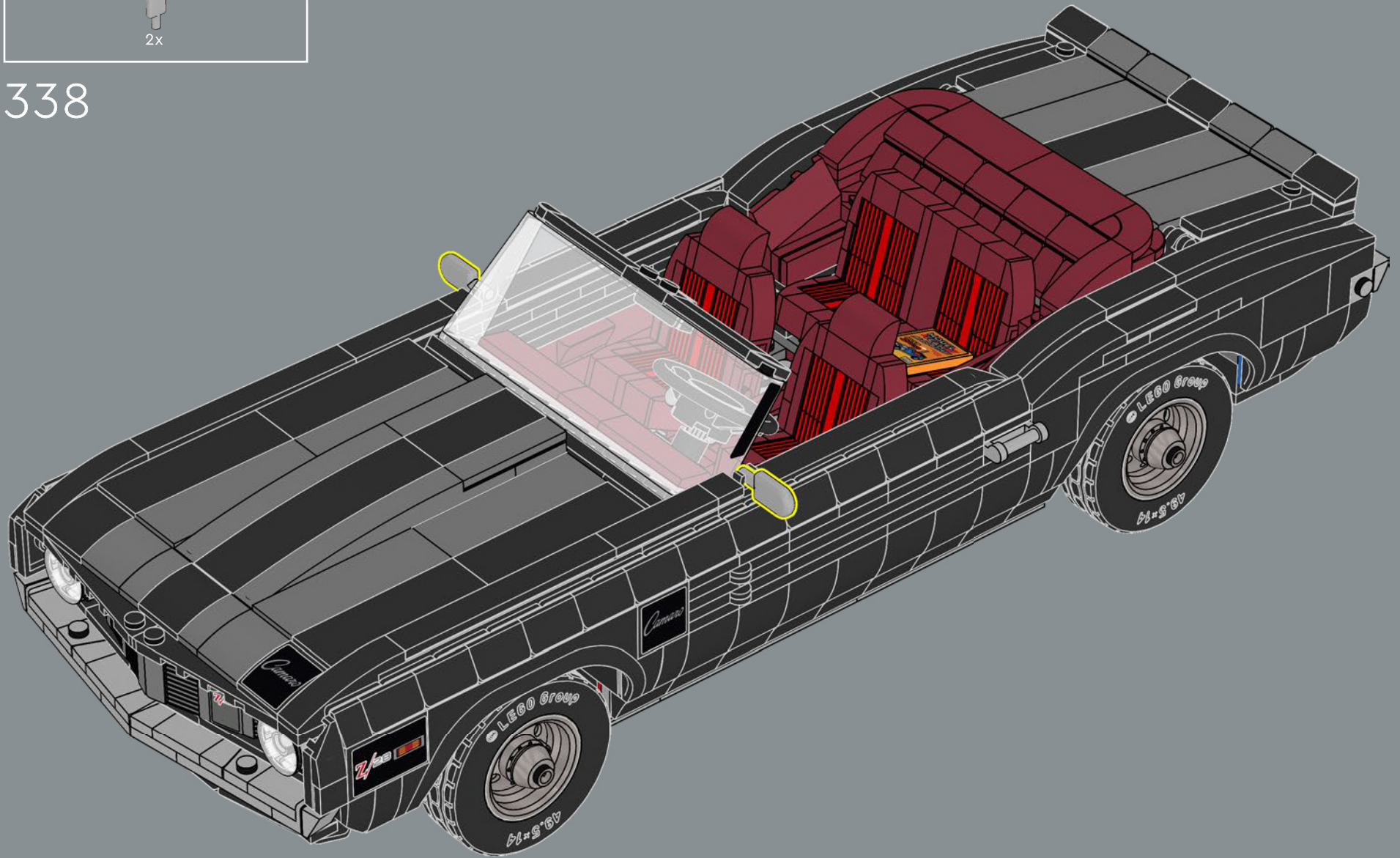

- 4x 4547489
- 2x 6034044
- 2x 6047220
- 4x 6276981
- 2x 6383985
- 4x 302201
- 2x 243101
- 2x 371001
- 2x 6104805
- 3x 302001
- 8x 6332042
- 2x 6035405
- 2x 6242241
- 3x 6347287
- 1x 6265740
- 2x 6146525
- 2x 614101
- 1x 6371416
- 1x 6289797
- 2x 4162465
- 8x 4118793
- 2x 6360037
- 8x 6024495
- 6x 4523145
- 8x 4121921
- 3x 4143409
- 3x 4249019
- 6x 6253003
- 2x 6013938
- 4x 4666579
- 2x 6416525
- 24x 6219677
- 2x 300321
- 2x 4558886
- 1x 654121
- 2x 370021
- 2x 6385920
- 1x 6275178
- 1x 330021
- 2x 307021
- 2x 302321
- 4x 6092565
- 2x 306921
- 6x 362321
- 2x 6378120
- 12x 371021
- 1x 303221
- 1x 303421
- 2x 6337002
- 2x 6347308
- 6x 6261351
- 5x 6168634
- 1x 6266205
- 8x 6168619
- 1x 6271820
- 3x 4142865
- 4x 6347789
- 1x 6130002
- 6x 393721
- 2x 300223
- 6x 6290531
- 1x 4212411
- 1x 6171063
- 2x 6057802
- 2x 306923
- 4x 6252060
- 2x 6196596
- 3x 303423
- 3x 6117968
- 4x 4206482
- 10x 6299413
- 2x 393723
- 2x 300524
- 2x 235724
- 2x 654124
- 14x 302324
- 1x 6171063
- 2x 6057802
- 2x 306923
- 4x 6252060
- 2x 6196596
- 3x 303423
- 3x 6117968
- 4x 4206482
- 10x 6299413
- 2x 393723
- 2x 300524
- 2x 235724
- 2x 654124
- 14x 302324
- 2x 6195183
- 2x 6271167
- 1x 6170294
- 1x 6331822
- 2x 366624
- 6x 6248833
- 10x 300526
- 2x 4644456
- 4x 300426
- 6x 362226
- 2x 300226
- 5x 301026
- 2x 4584274
- 3x 370226
- 4x 4504382
- 53x 4548180
- 2x 4121966
- 4x 6267487
- 6x 366526
- 12x 6069000
- 1x 303926
- 2x 6176768
- 4x 428626
- 6x 428726
- 1x 6064228
- 5x 6181720
- 4x 6273589
- 2x 4107558
- 4x 302426
- 2x 6388352
- 6x 307026
- 44x 302326
- 8x 306926
- 2x 6214807
- 14x 6192346
- 4x 306826
- 2x 6312724
- 10x 302226
- 6x 242026
- 4x 6133722
- 4x 6195271
- 1x 403226
- 5x 6181713
- 2x 6184784
- 10x 6047276
- 26x 6053077
- 2x 6211476
- 2x 4618880
- 2x 6280394
- 1x 6319983
- 1x 6316923
- 1x 6331026
- 6x 6037746
- 6x 4647286
- 1x 6296083
- 4x 6037664
- 6x 243126
- 6x 371026
- 7x 302026
- 4x 4560182
- 2x 6350415
- 3x 663626
- 12x 366626
- 11x 6318582
- 6x 416226
- 1x 303226
- 1x 395826
- 14x 447726

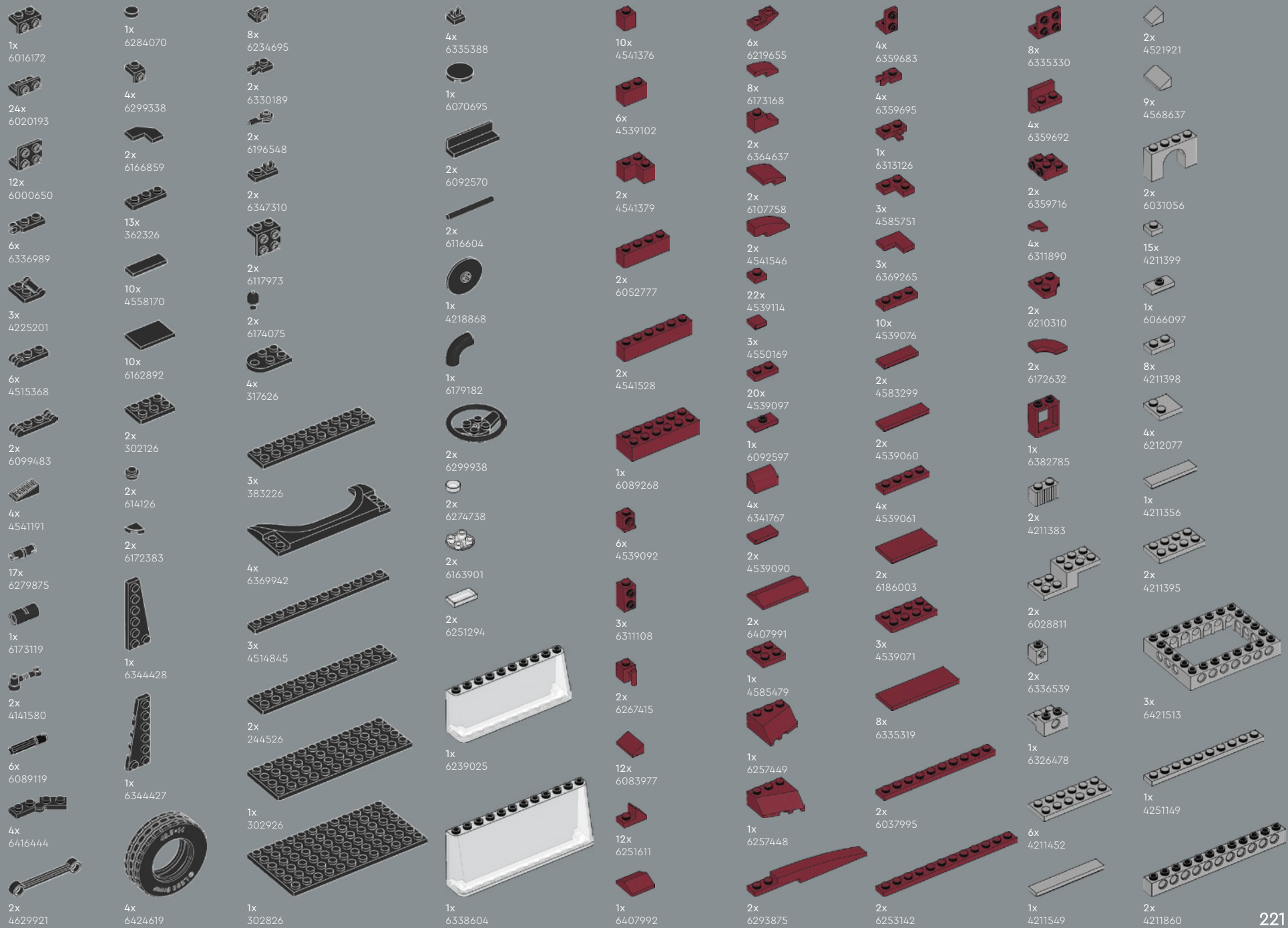



Customer Service
 Kundenservice
 Service Client
 Assistenza clienti
 Atención al cliente
 Serviço de Apoio ao Consumidor
 Ügyfélszolgálat
 Klientu apkalpošanas dienests
 Serviciul pentru clienț
 客户服务
 コンシューマーサービス
 고객 서비스
LEGO.com/service

3

5



FEEDBACK AND WIN



FEEDBACK AND WIN

Your feedback will help shape the future development of this product series.

Please visit:

FEEDBACK UND GEWINNEN

Dein Feedback trägt zur Weiterentwicklung dieser Produktreihe bei.

Geh auf:

COMMENTEZ ET GAGNEZ

Vos commentaires nous aideront à concevoir les futurs produits de cette gamme.

Rendez-vous sur :

COMENTA Y GANA

Tu opinión nos ayudará a dar forma al desarrollo de esta serie de productos en el futuro.

Visita:

反馈有奖

您的反馈将有助于我们在今后改进本系列产品。

请访问：

[LEGO.com/productfeedback](https://www.lego.com/productfeedback)

By completing, you will automatically enter a drawing to win a LEGO® set.

Terms & Conditions apply.

Durch Ausfüllen nimmst du automatisch an der Verlosung eines LEGO® Preises teil.

Es gelten die Teilnahmebedingungen.

En envoyant vos commentaires, vous serez automatiquement inscrit(e) à un tirage au sort qui vous permettra de remporter un prix LEGO®.

Offre soumise à conditions.

Al contestar, participarás automáticamente en el sorteo y podrás ganar un set LEGO®.

Sujeto a Términos y Condiciones.

完成我们的反馈调查，即可自动进入抽奖环节，赢取乐高®套装。

适用《条款和条件》。



LEGO and the LEGO logo are trademarks of the LEGO Group. ©2022 The LEGO Group.

General Motors trademarks used under license to the LEGO Group.