



# NINJAGO

Masters of Spinjitzu

2506



1

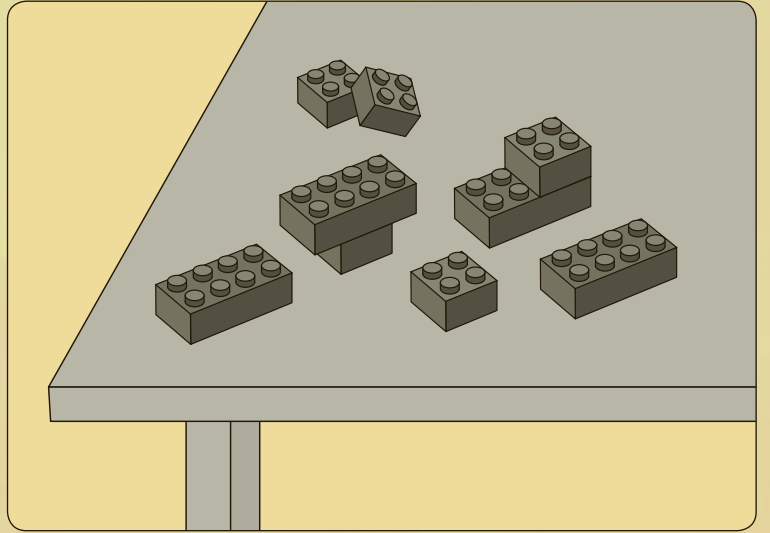
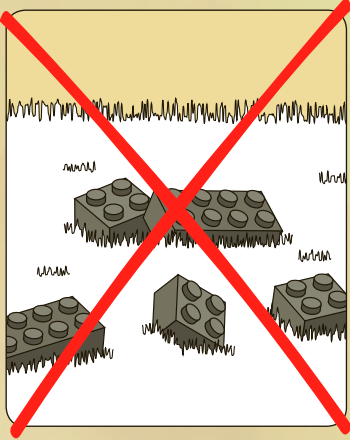

2



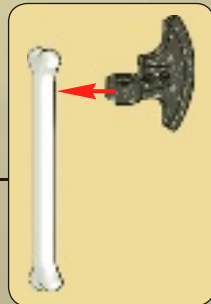
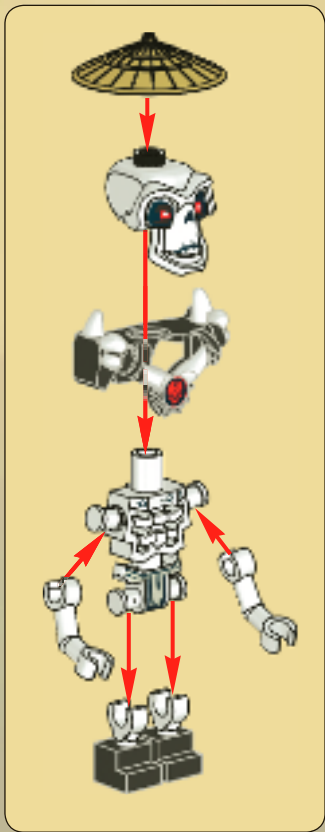
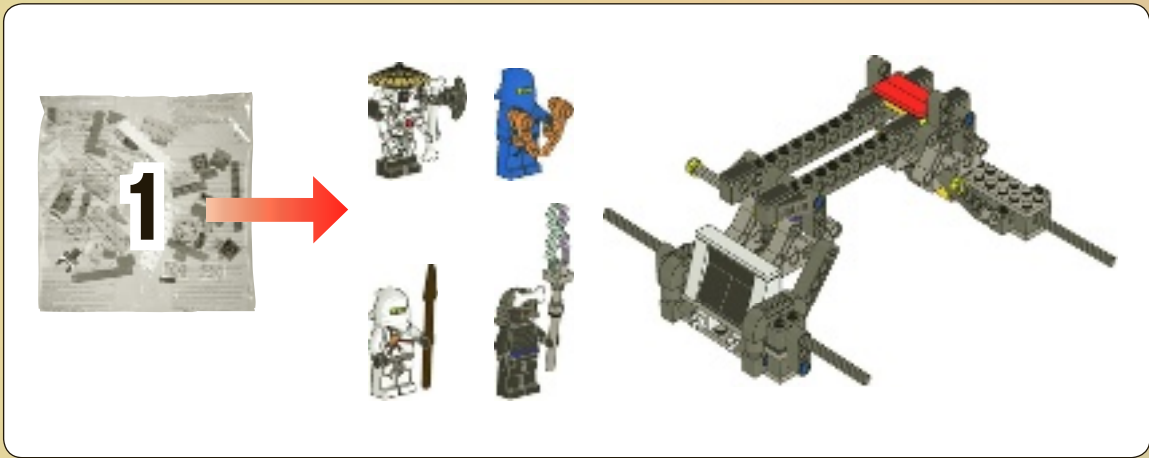

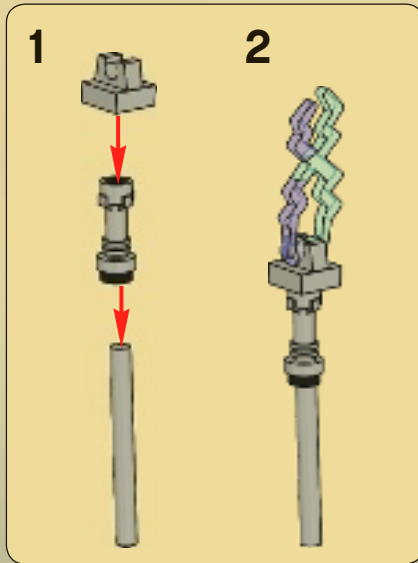
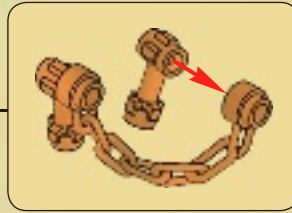

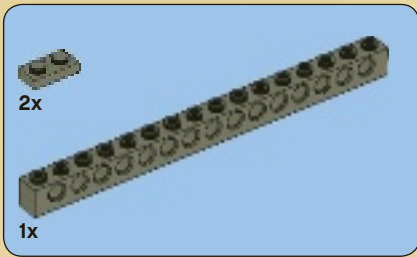
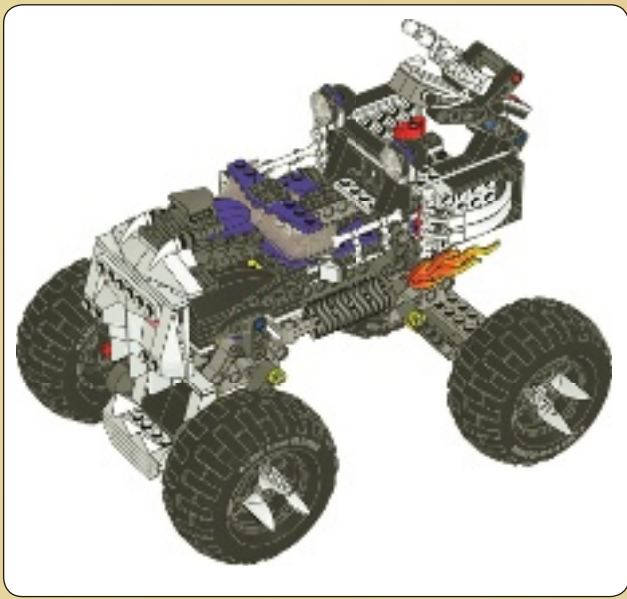

1

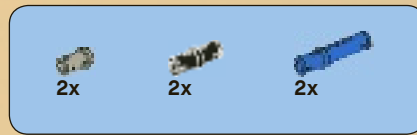
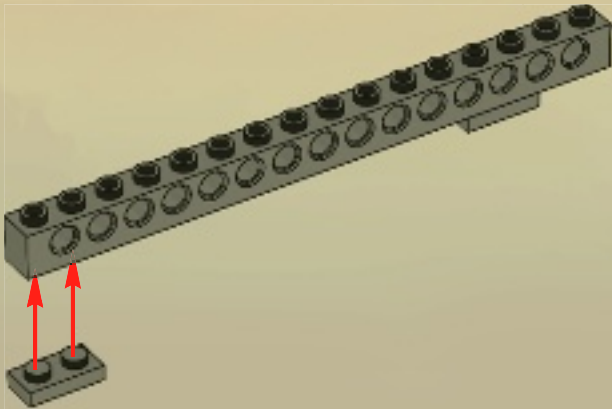

2

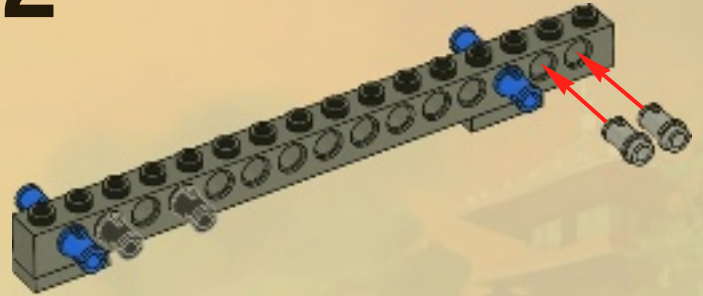

3

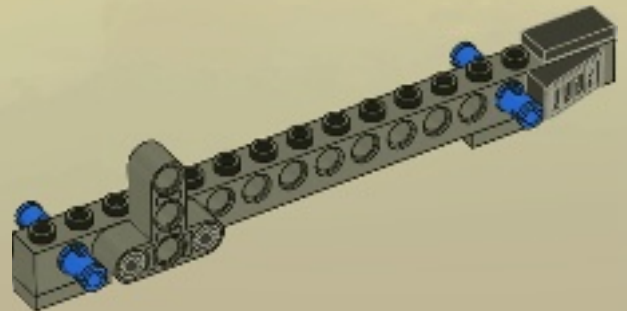



4

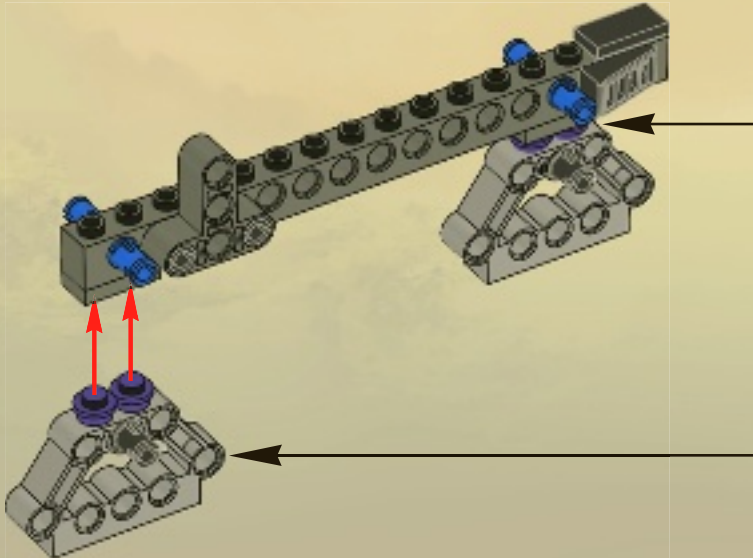
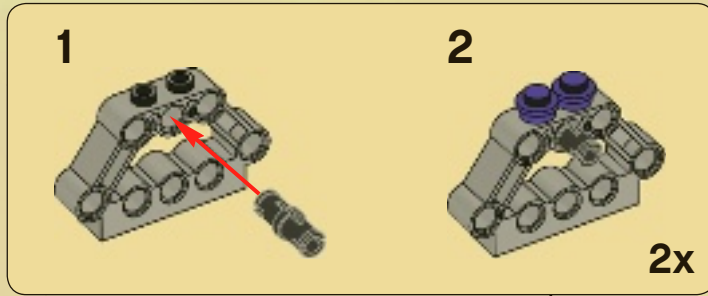

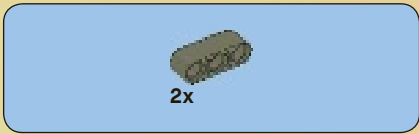

5

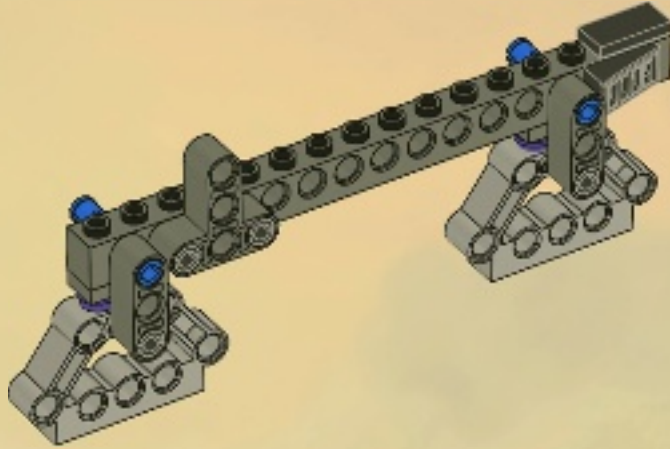

6

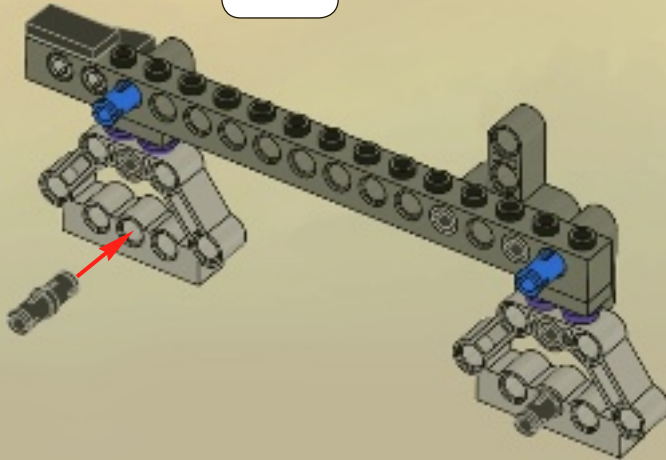



2x

7

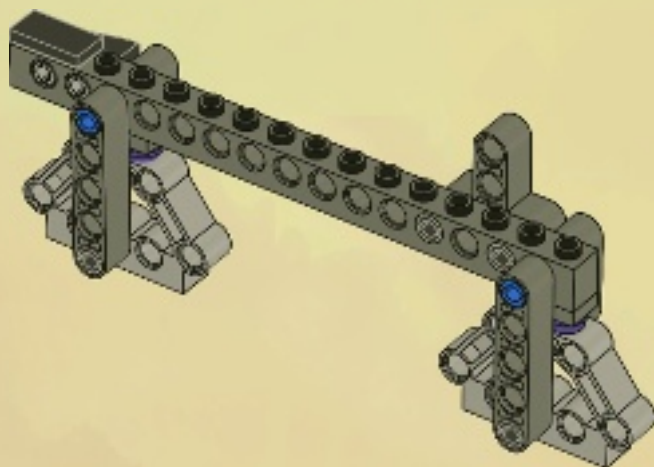

2x

8

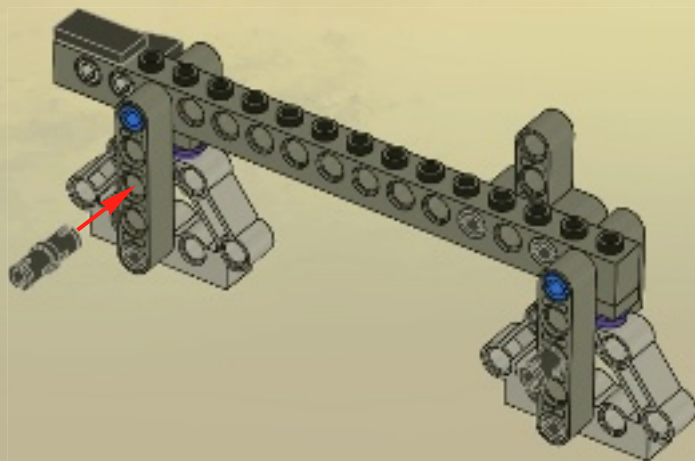





9

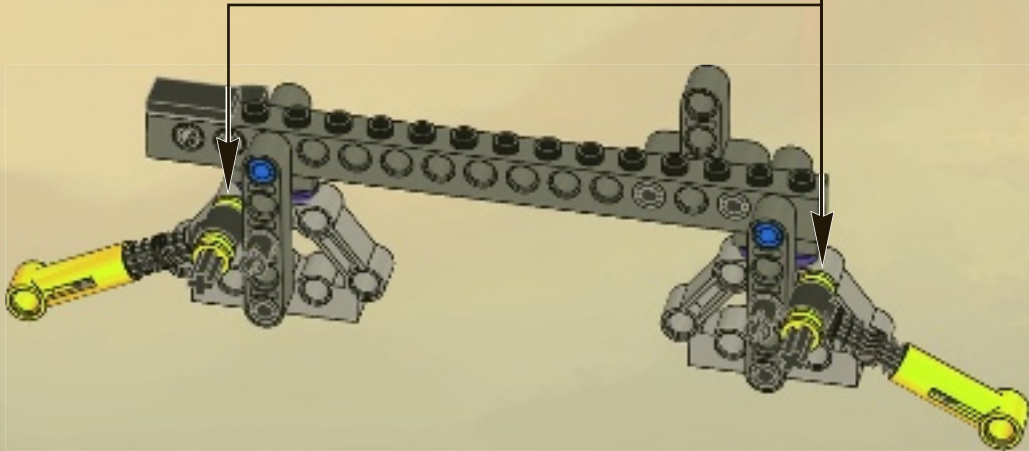

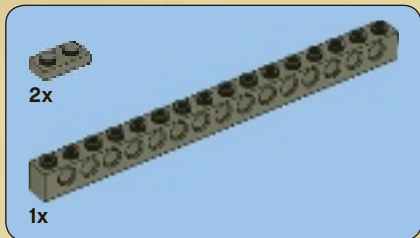
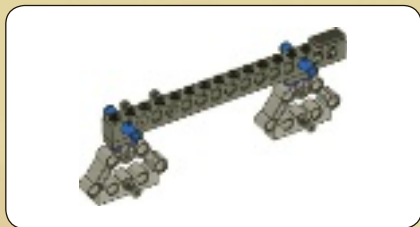

1

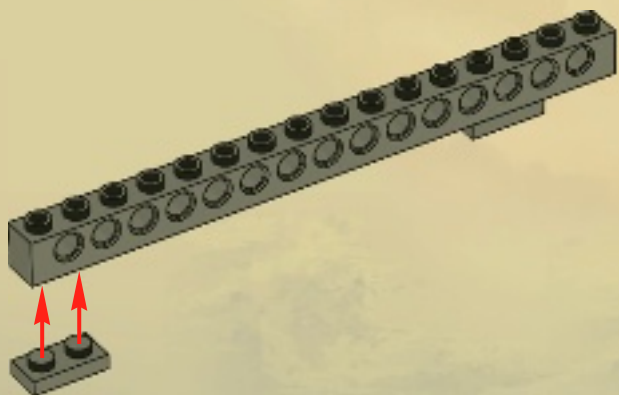

2

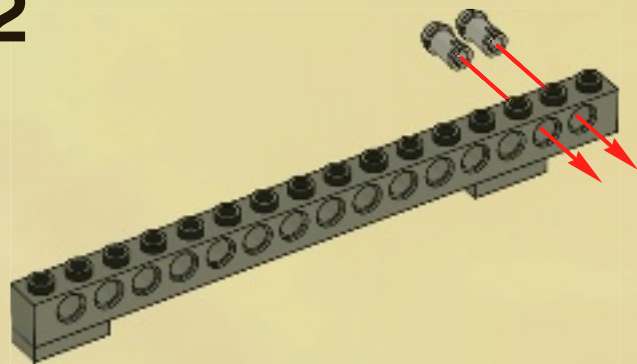

3

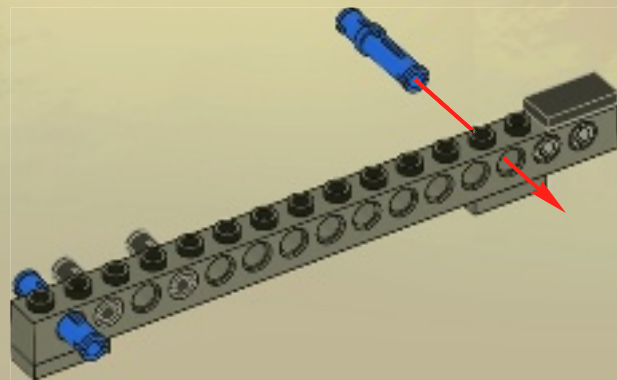



4

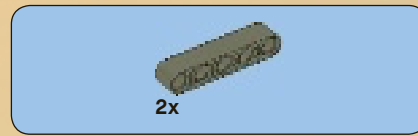
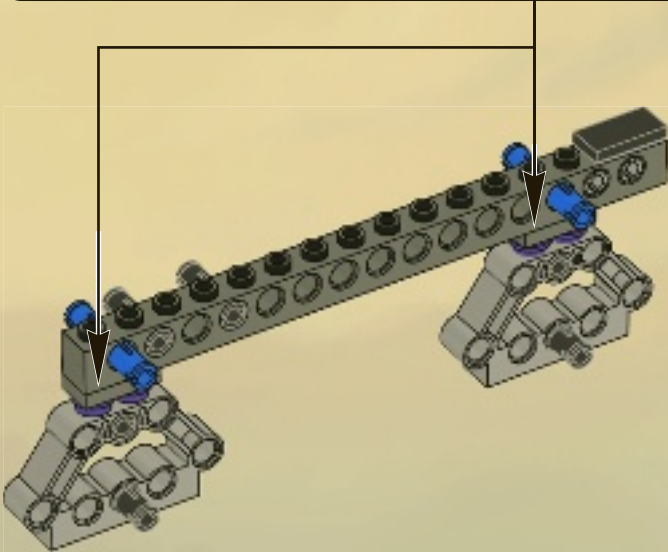
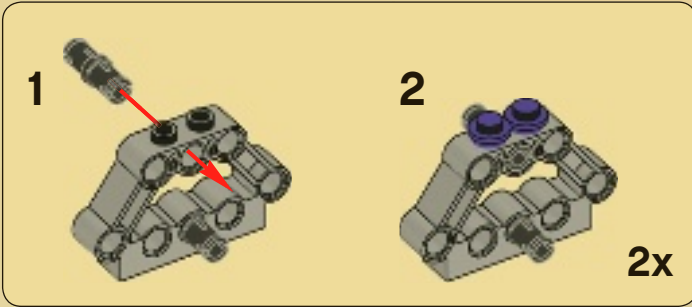

5

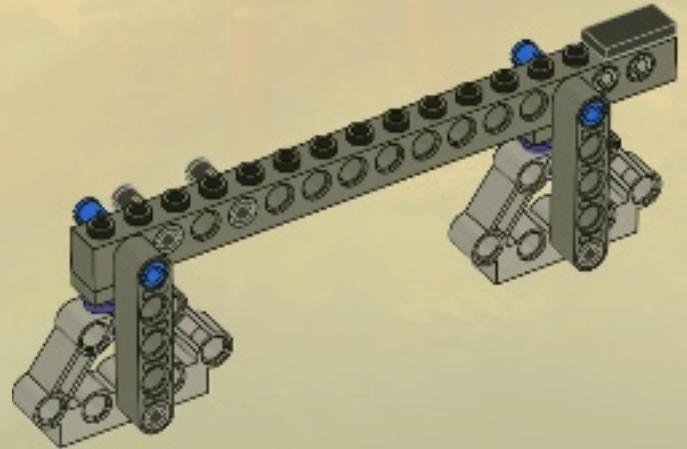

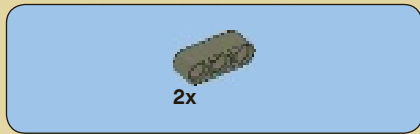

6

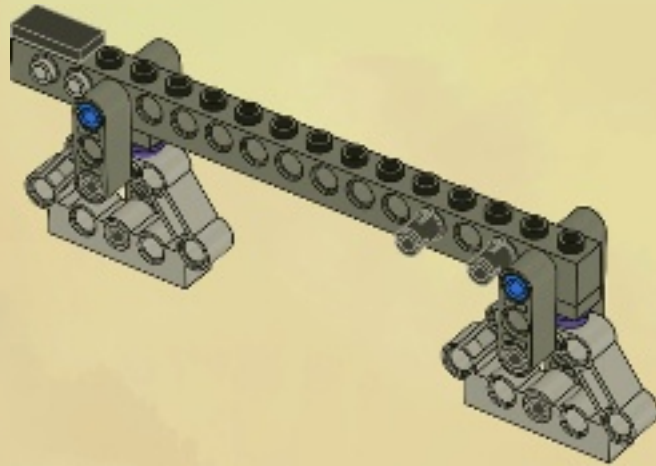

10

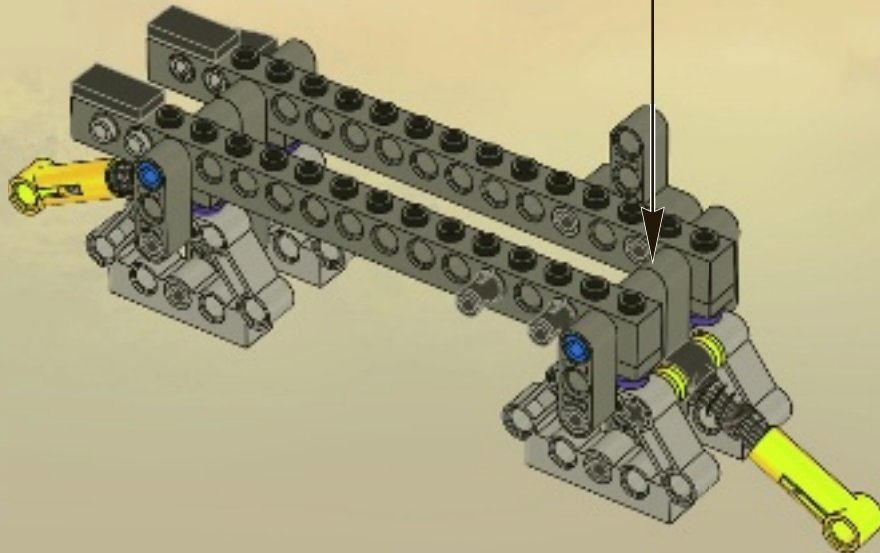



11

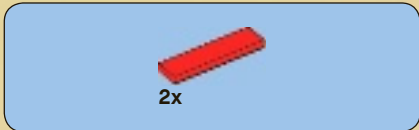
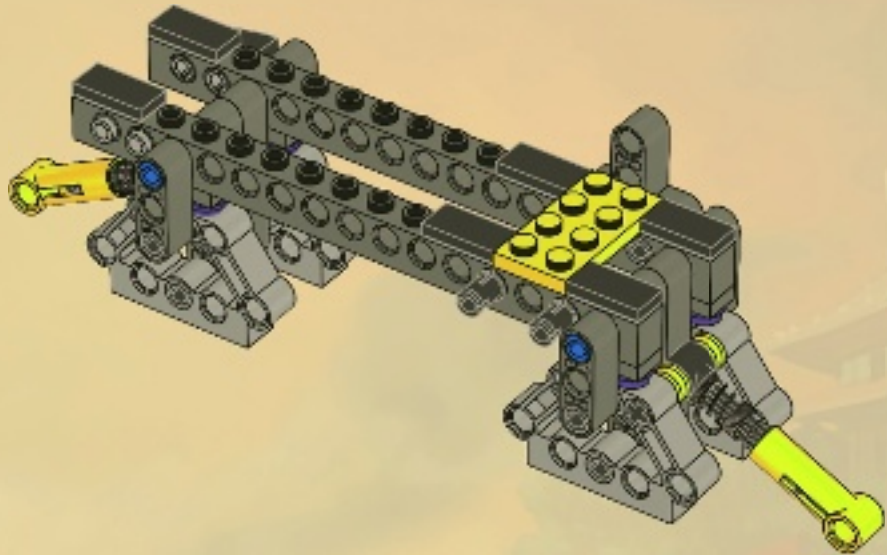

12

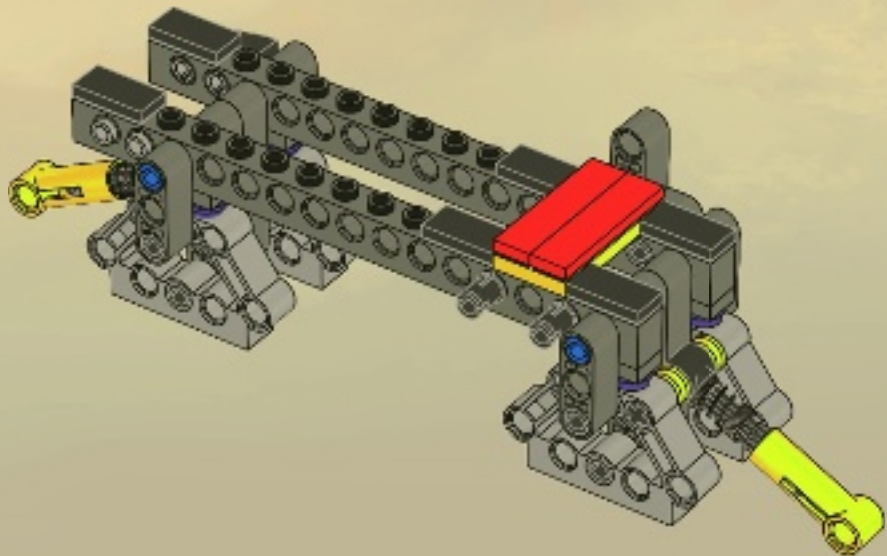

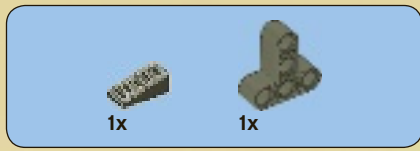

# 13

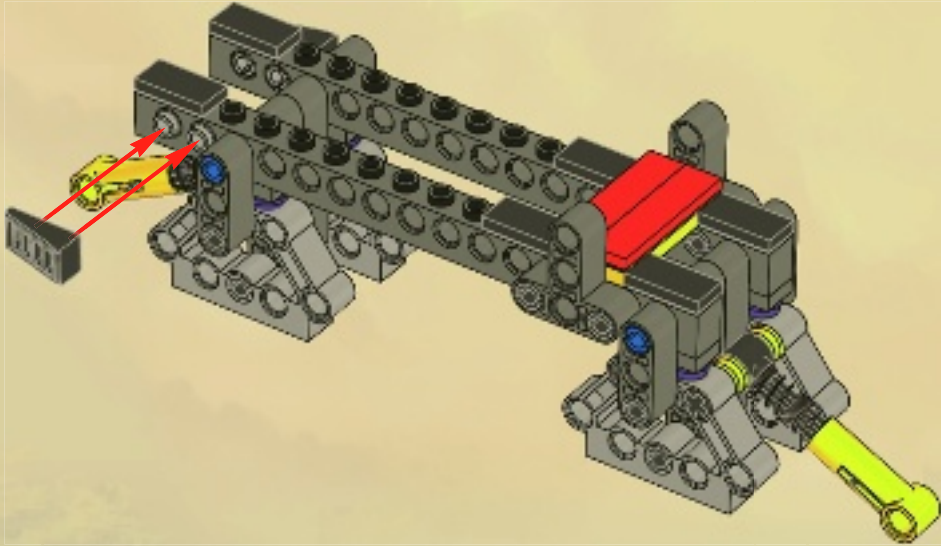

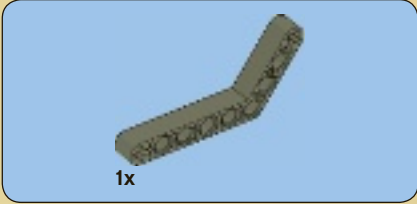
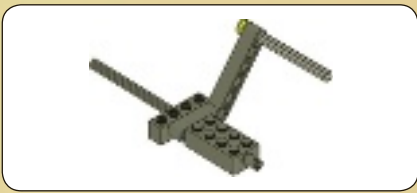

1

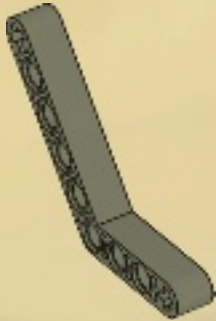

2

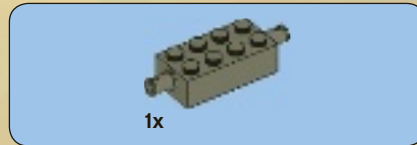
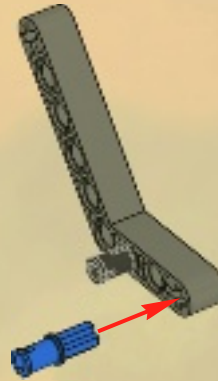

3

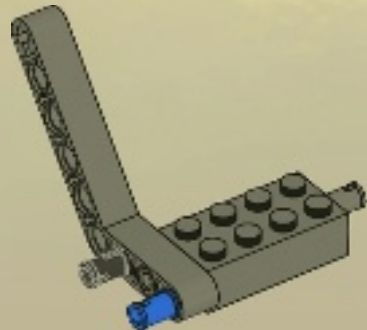

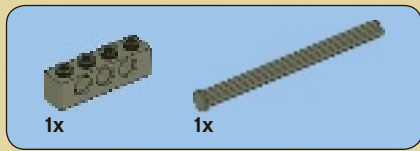

4

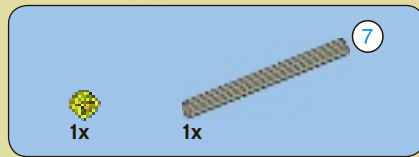
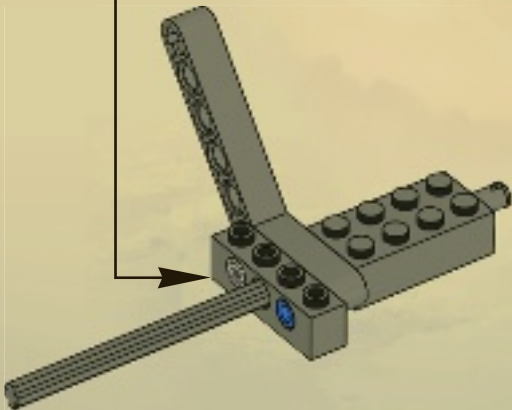
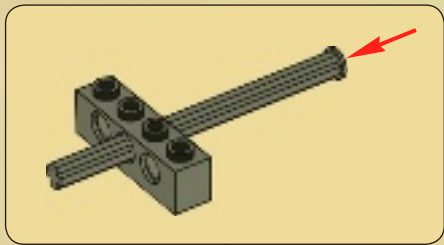

5

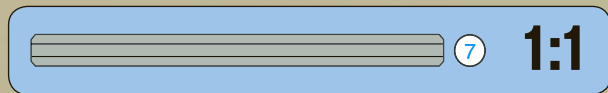
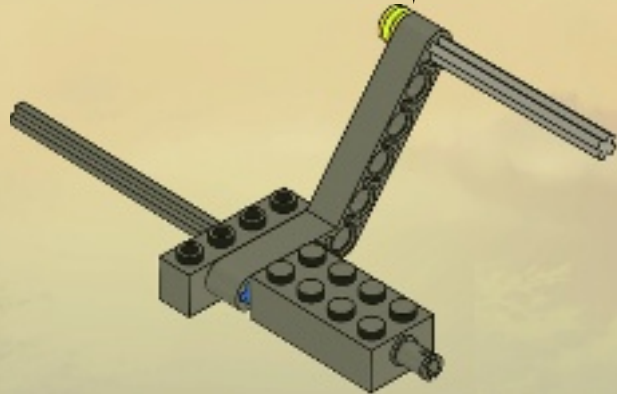
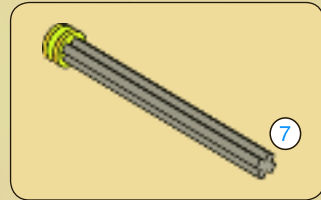



14

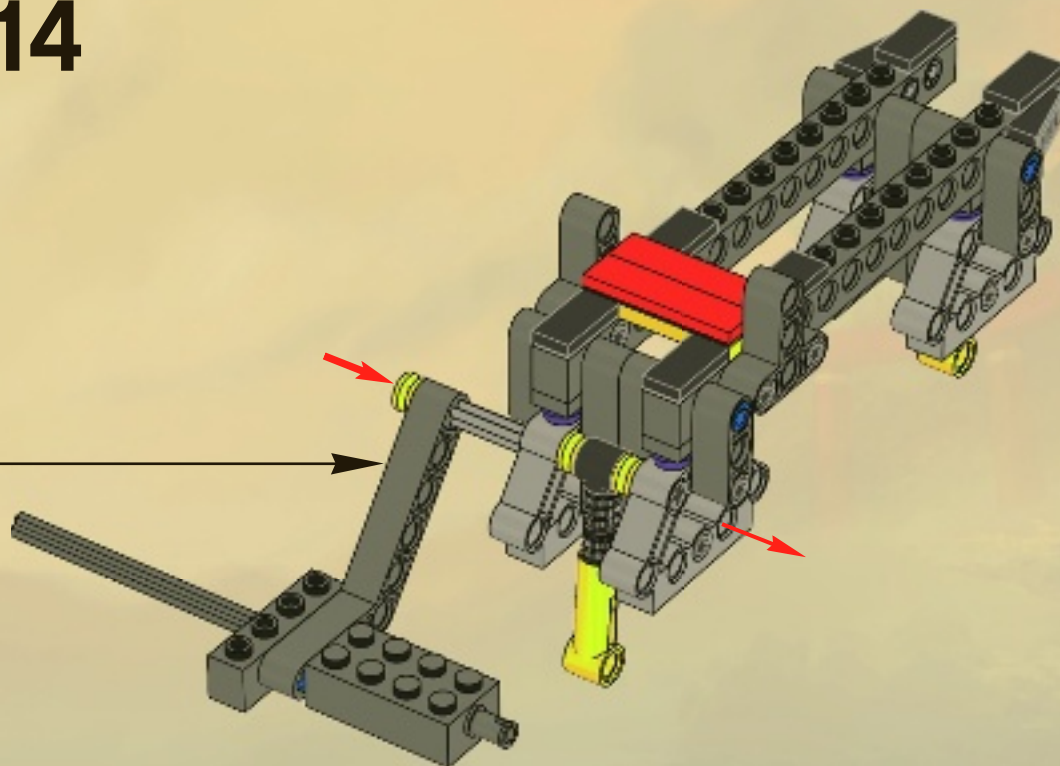

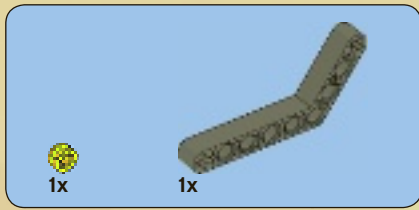

15

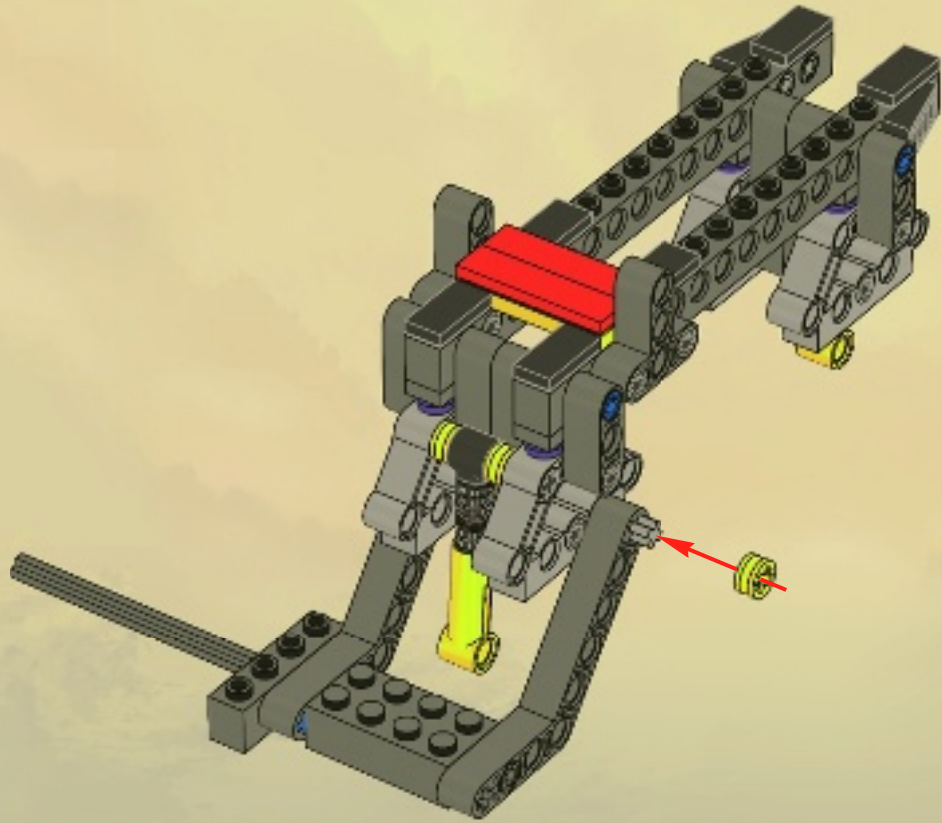



1x



1x

# 16

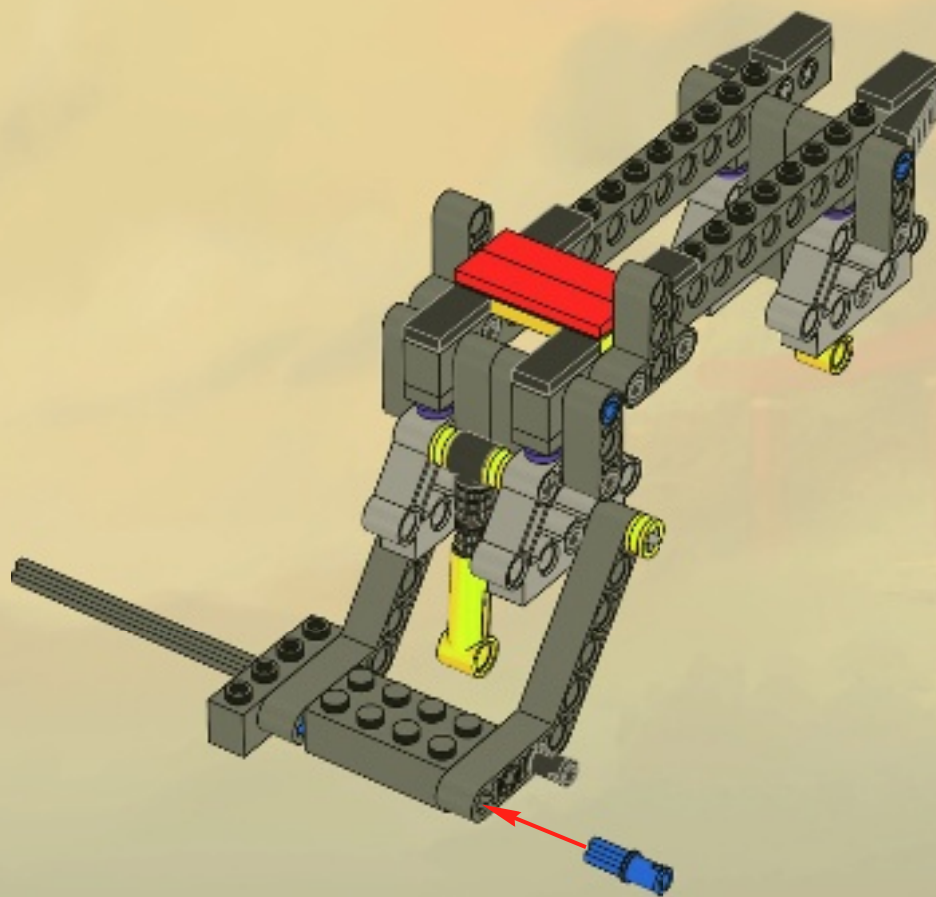

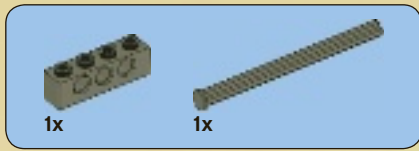

17

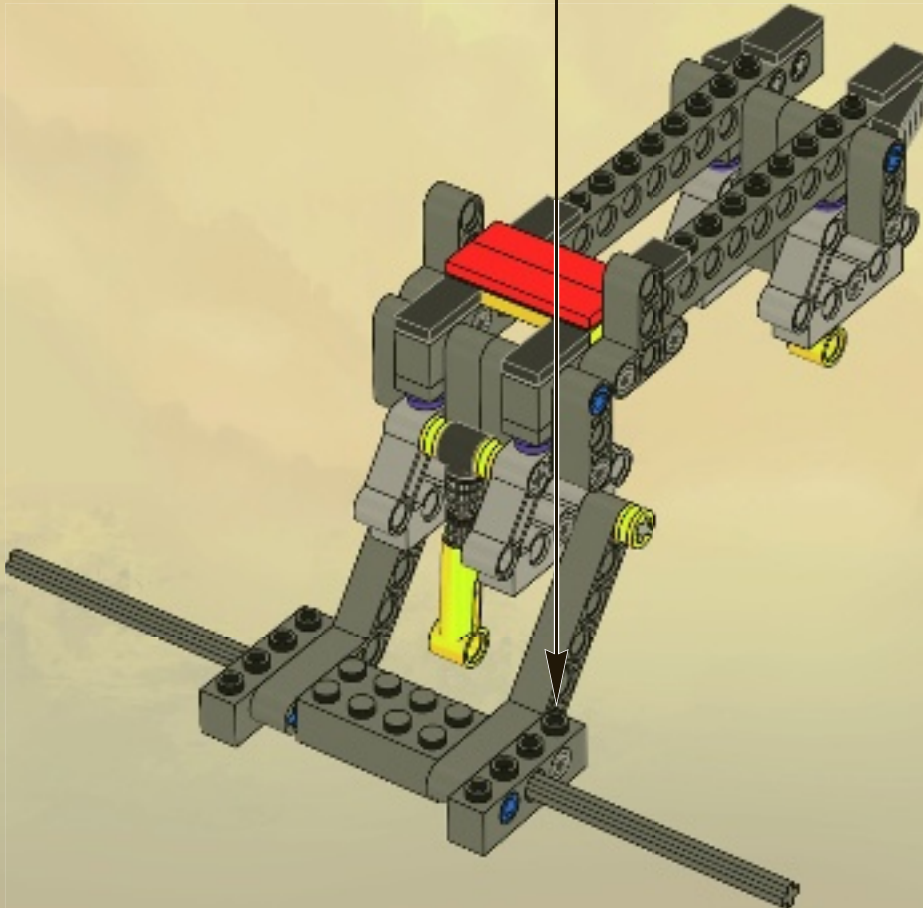
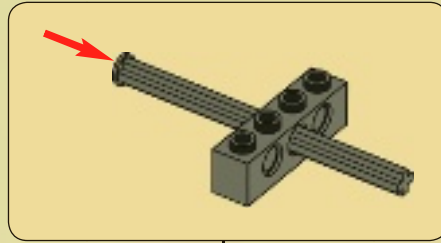



2x

# 18

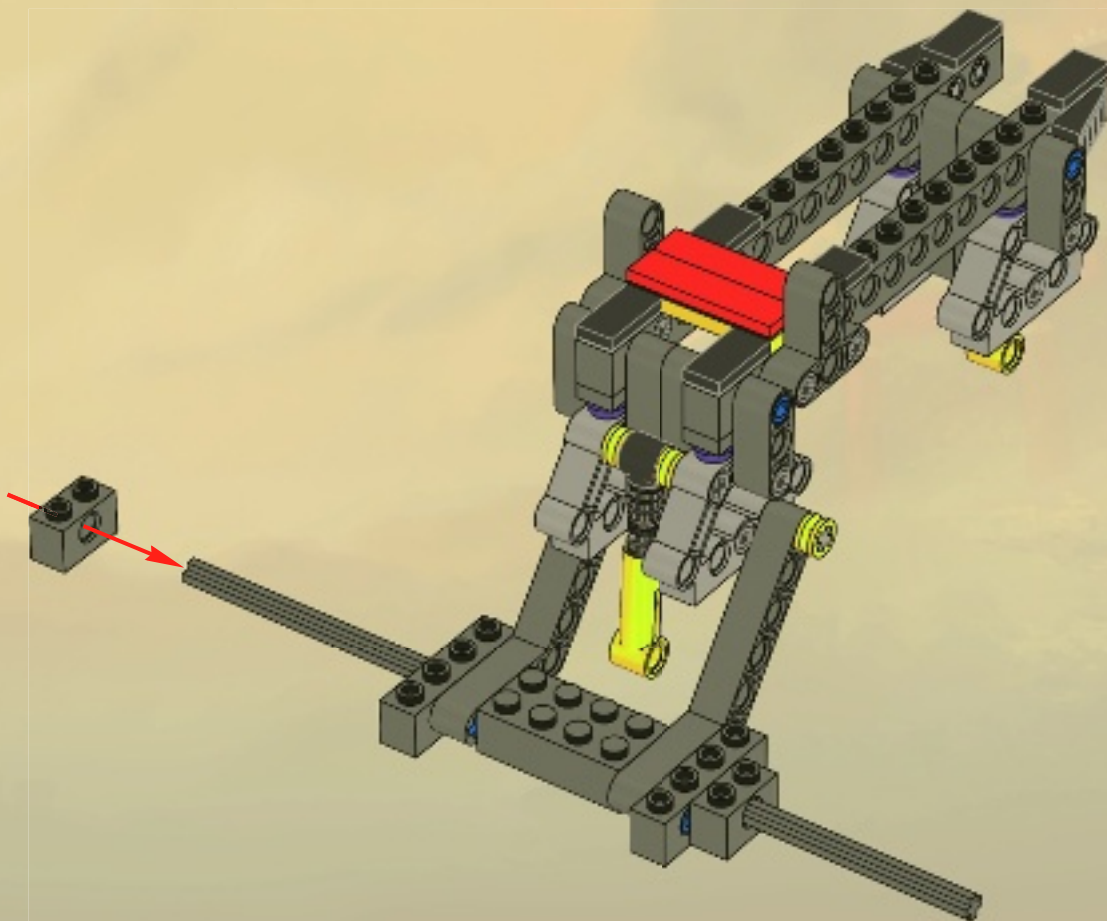

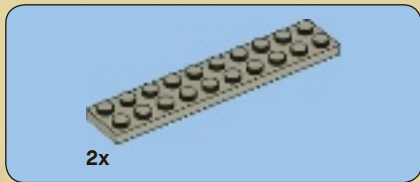

19

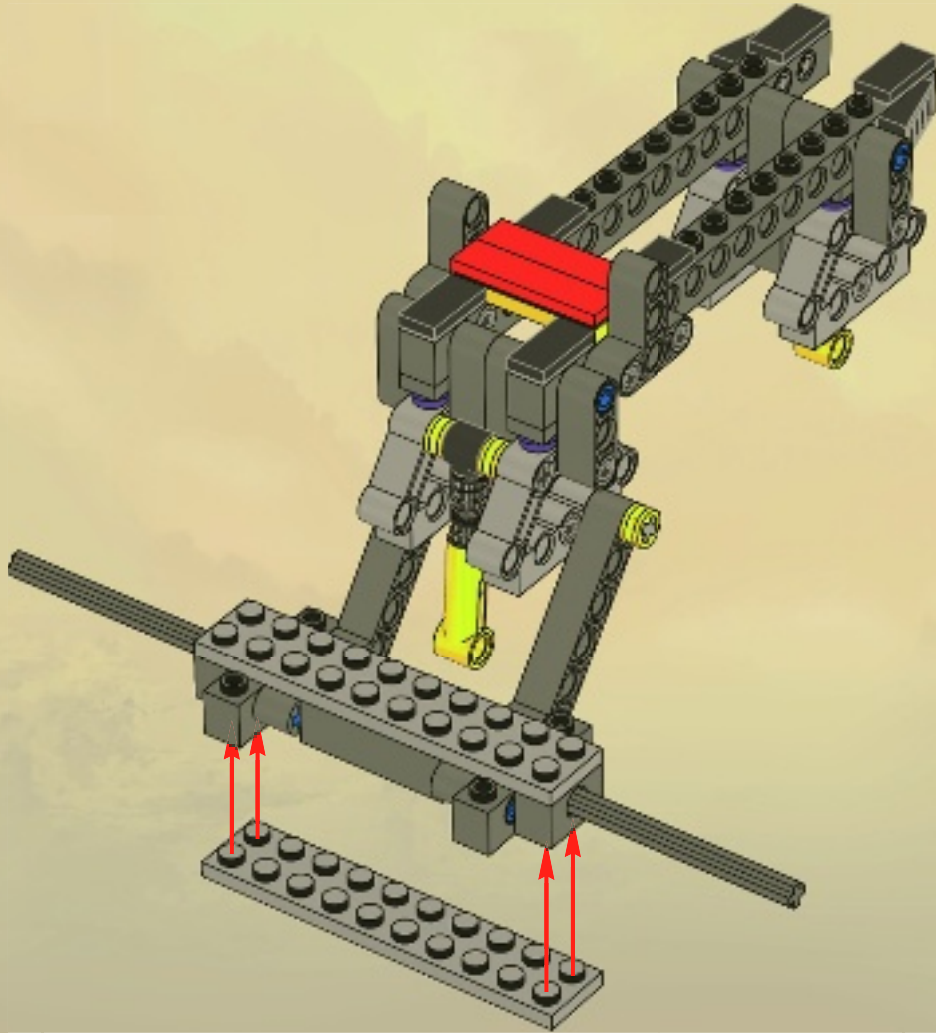

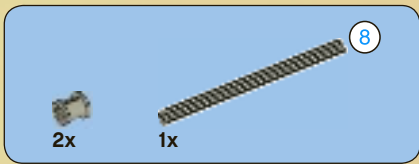

20

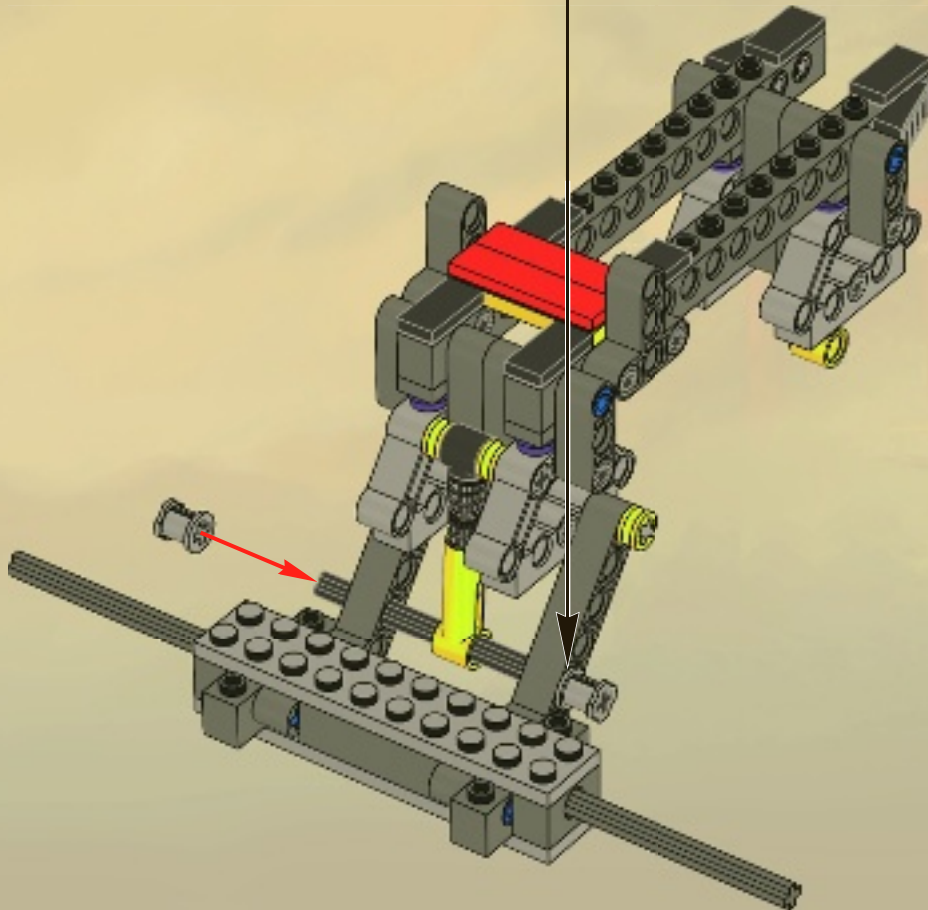
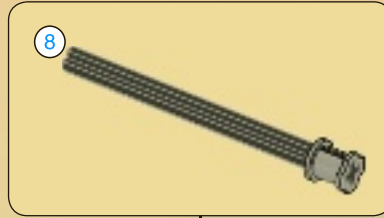

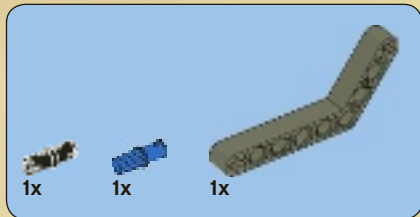
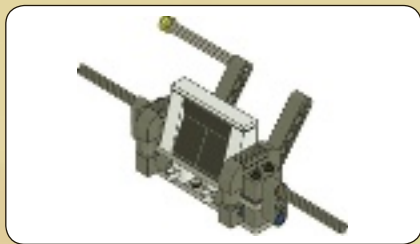

1

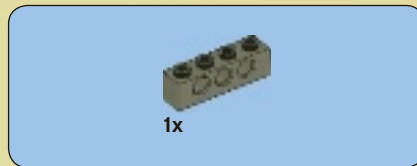
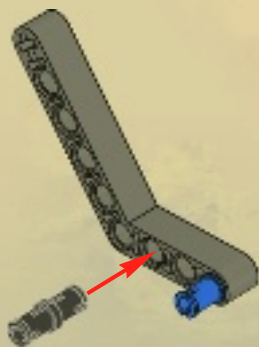

2

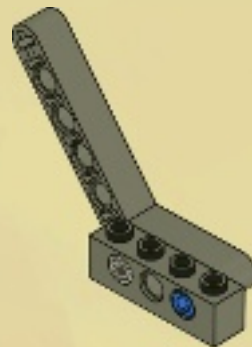

3

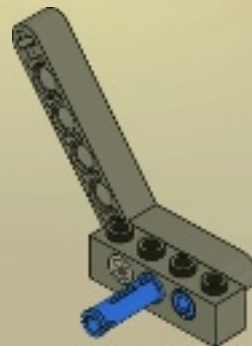



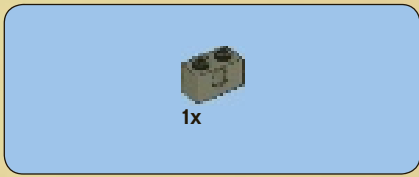

4

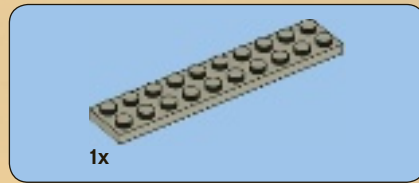
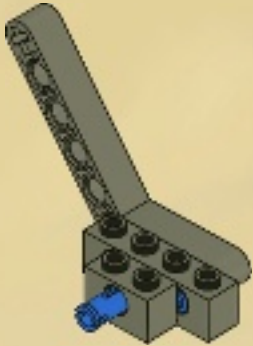

5

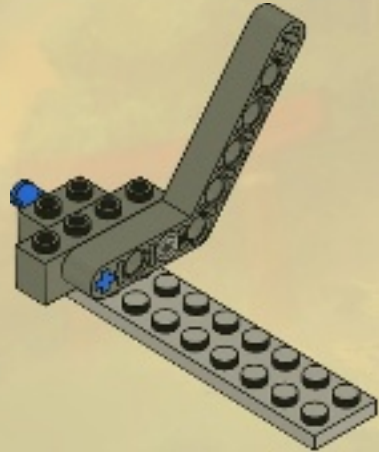

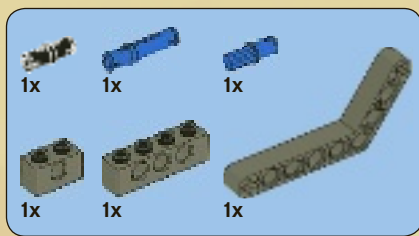

6

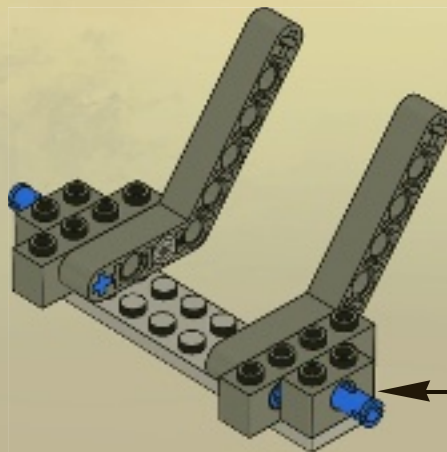
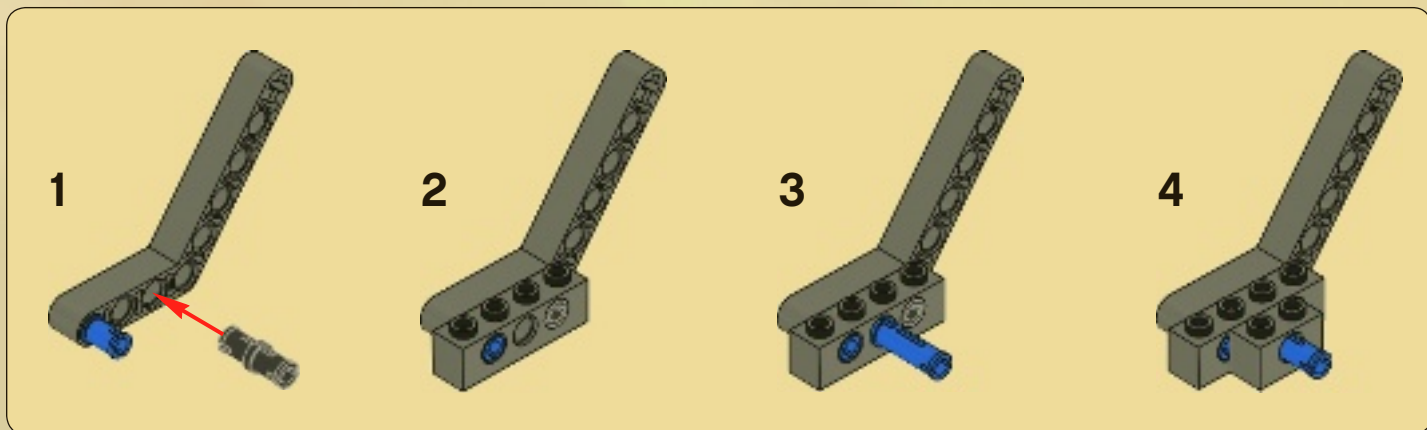



2x

7

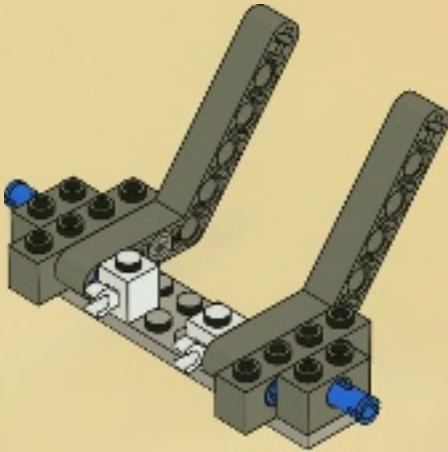

1x

8

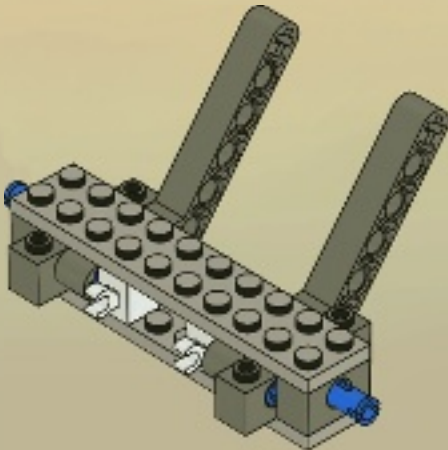

4x

9

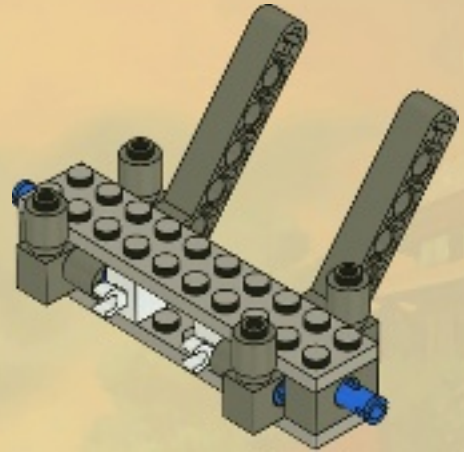

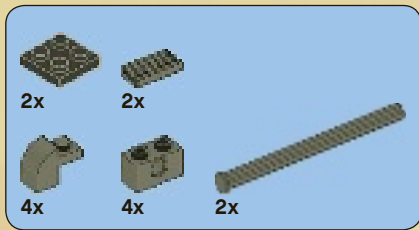

# 10

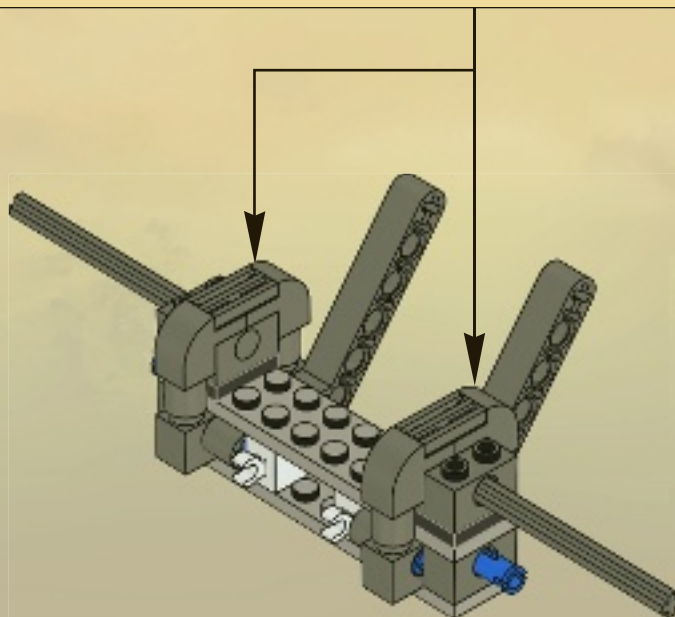

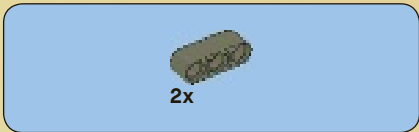

11

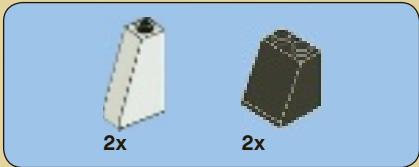
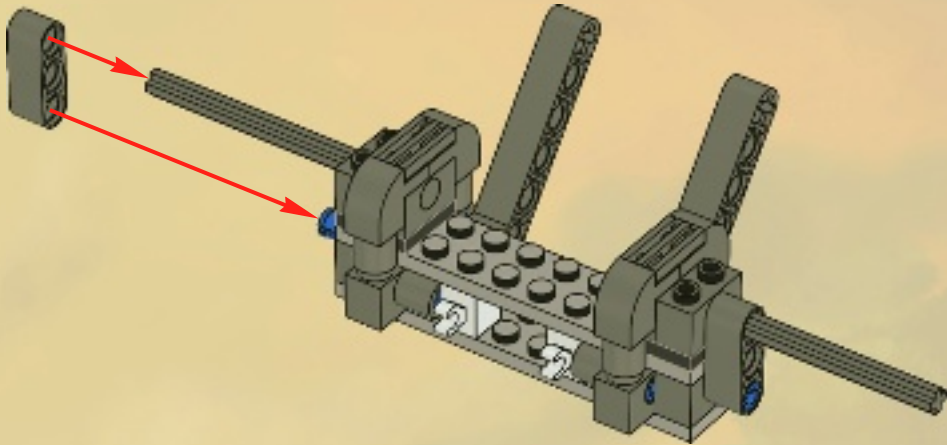

12

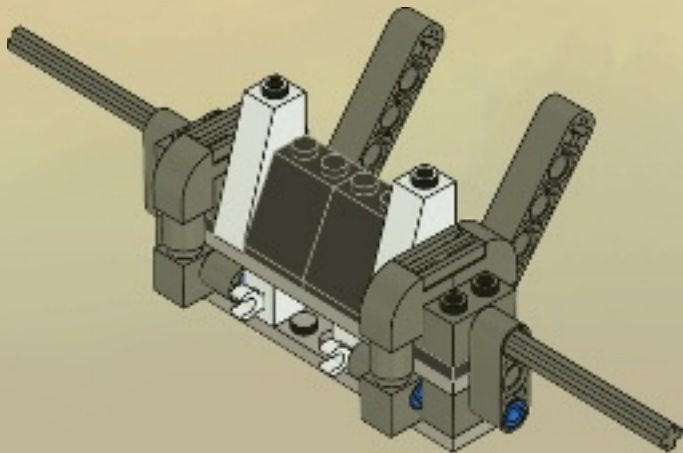

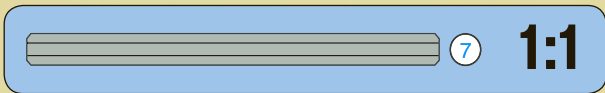
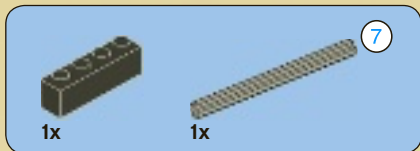

13

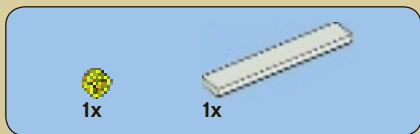
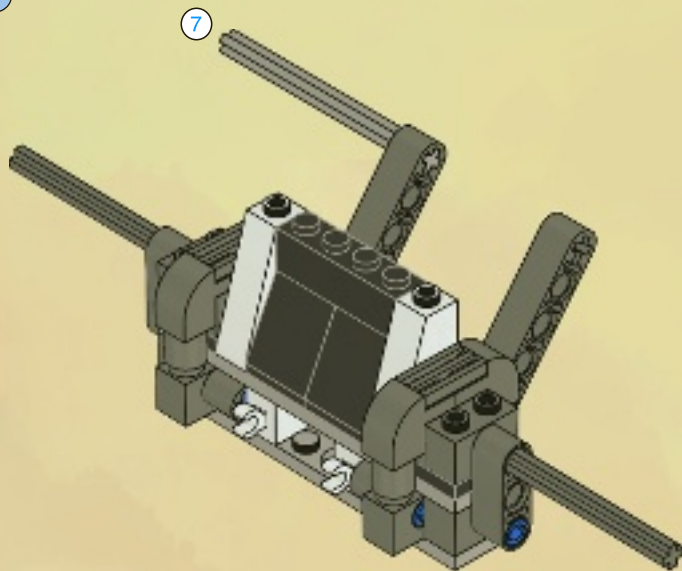

14

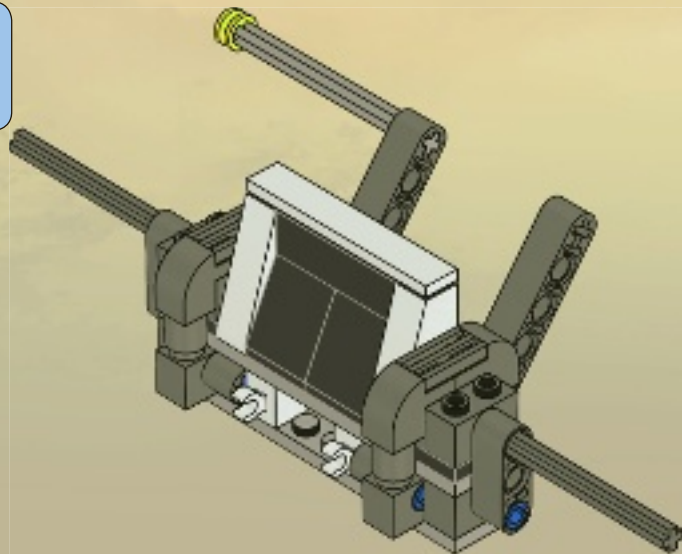



1x

# 21

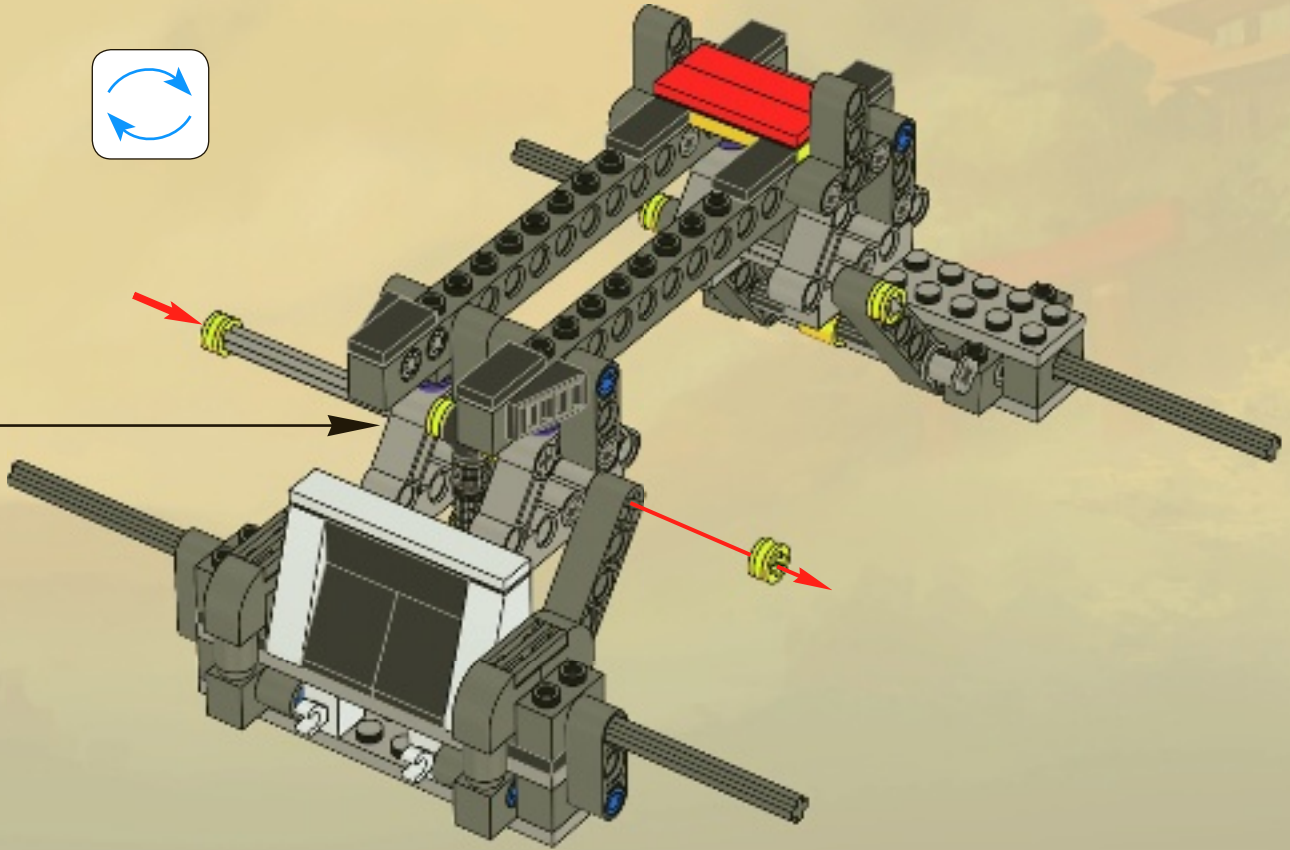

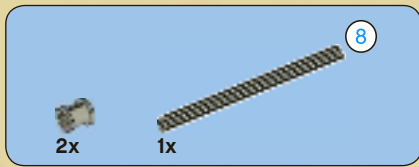

22

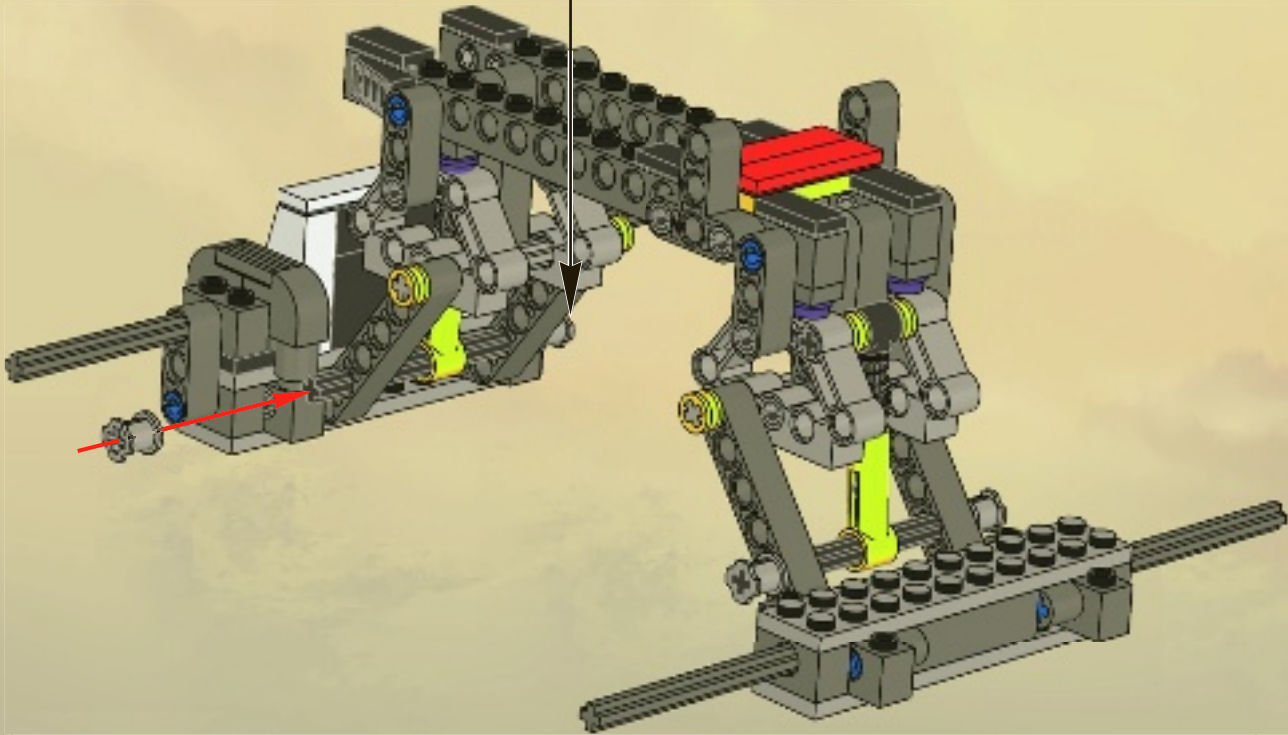
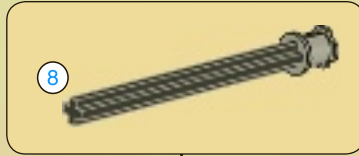



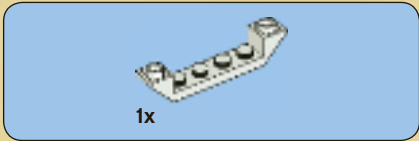
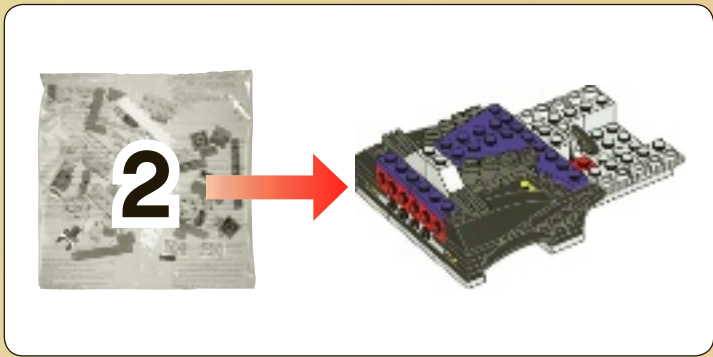

**1**

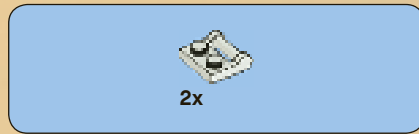
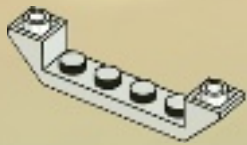

**2**

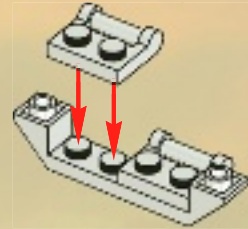

**3**

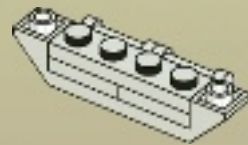



4

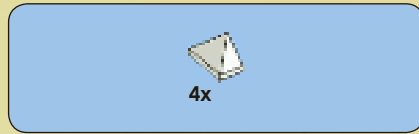
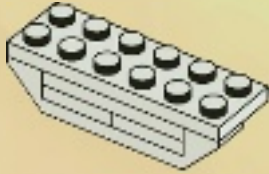

5

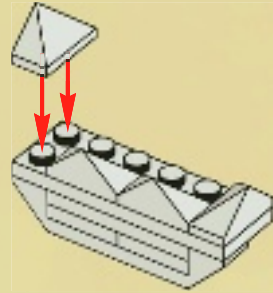

23

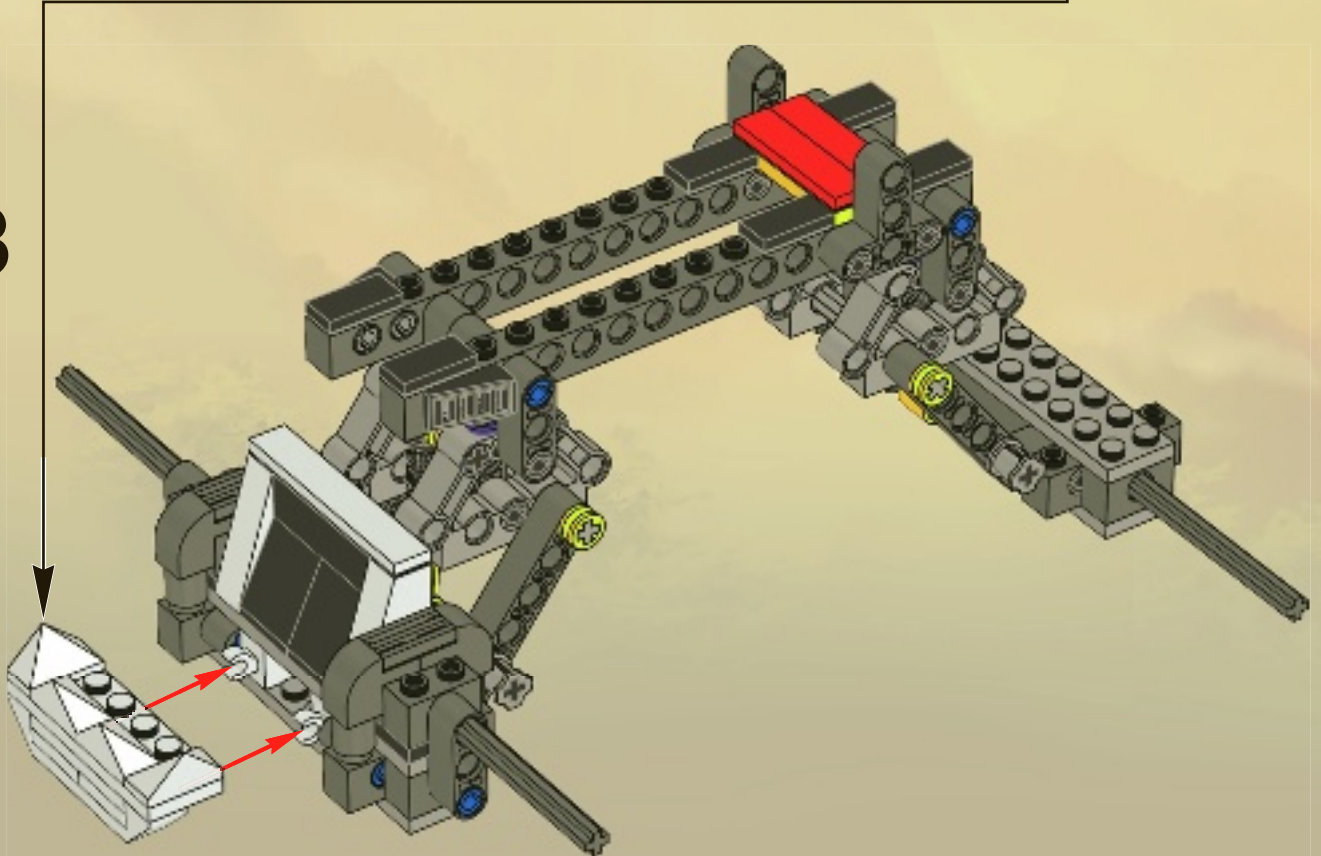

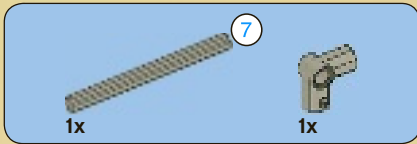

1

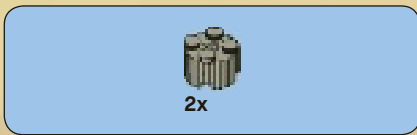
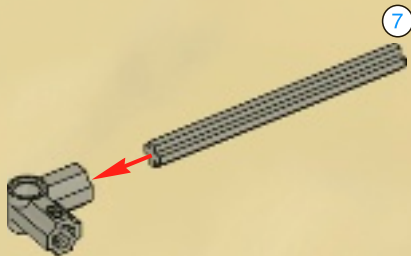

2

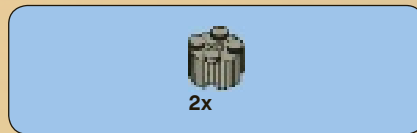
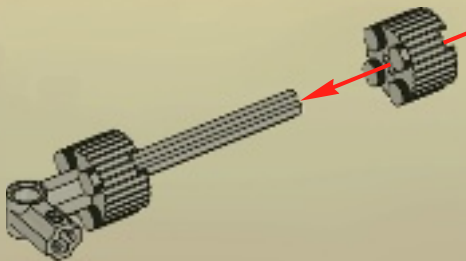

3

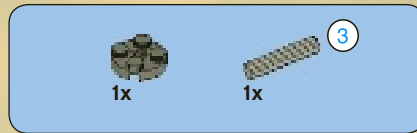
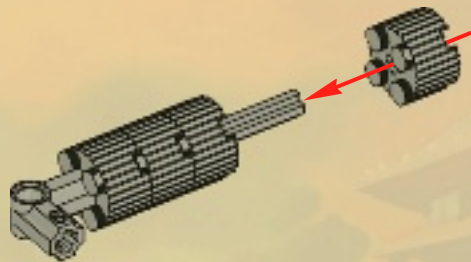

4

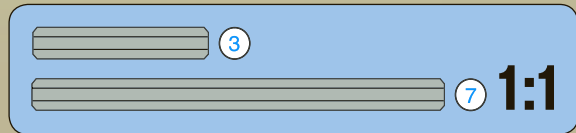
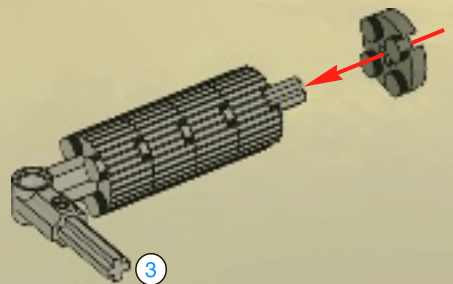



5

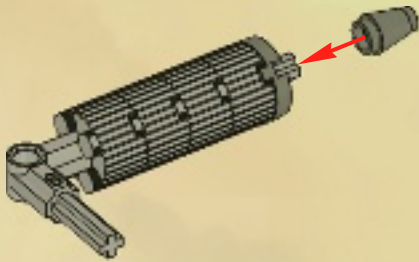

6

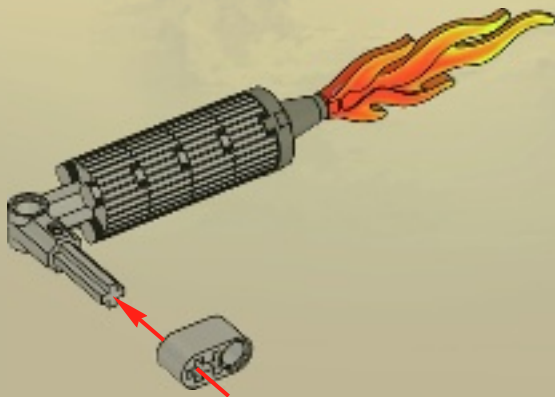

7

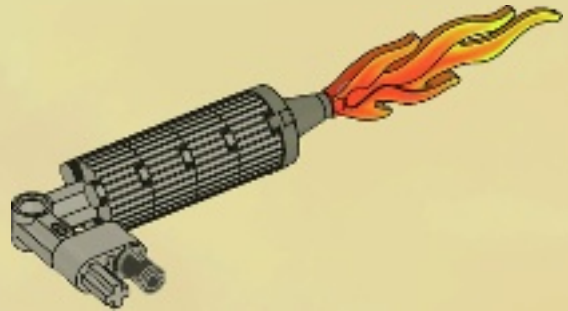

2x

24

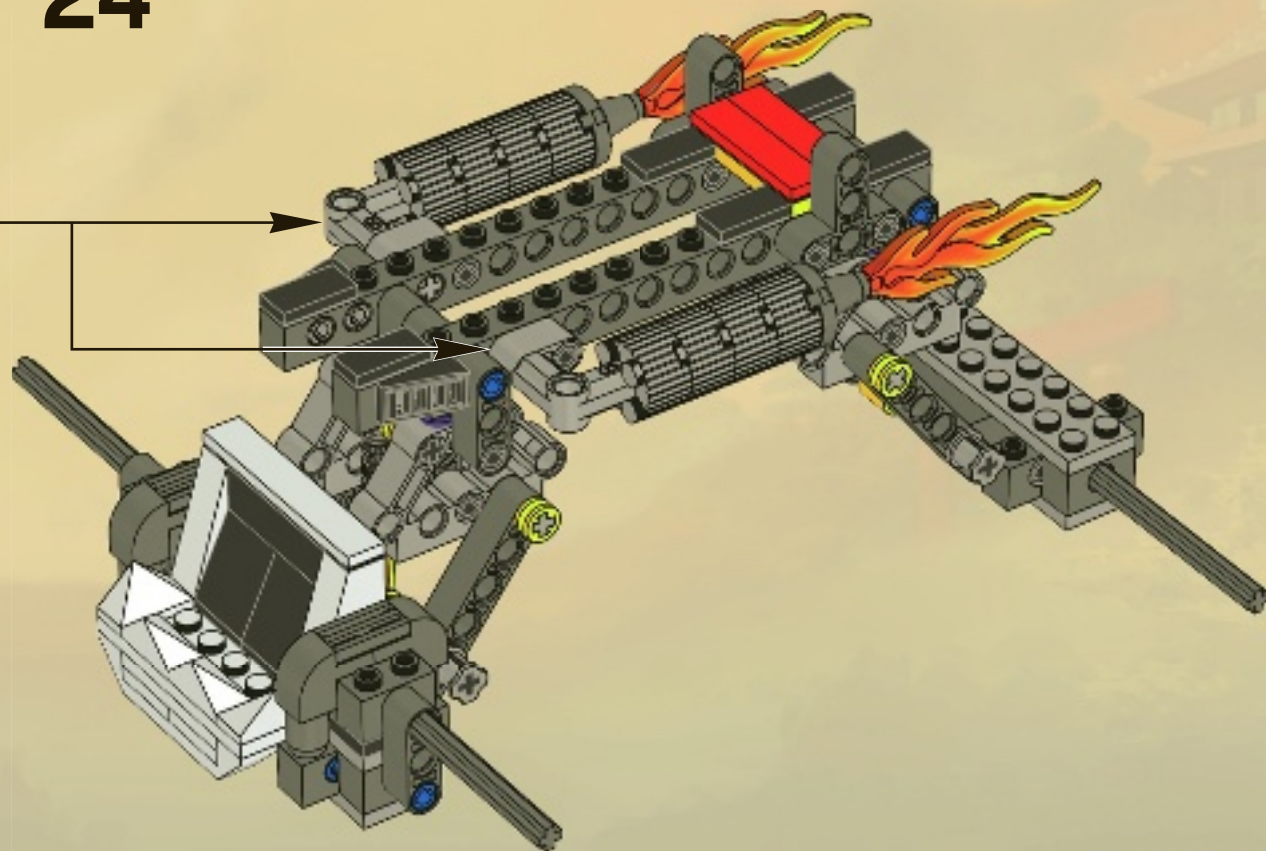

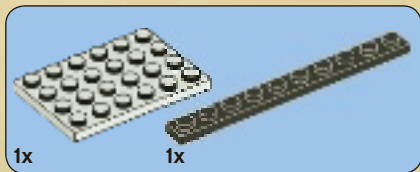
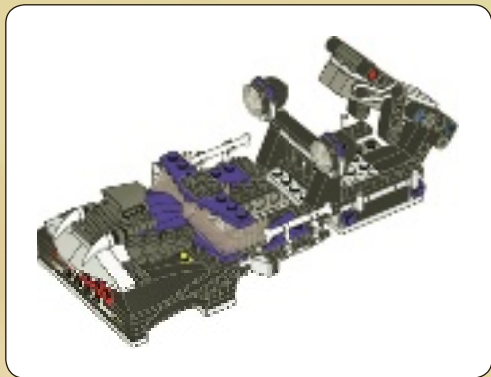

1

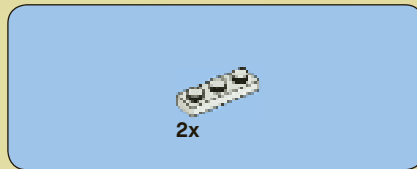
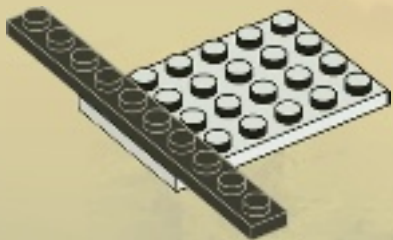

2

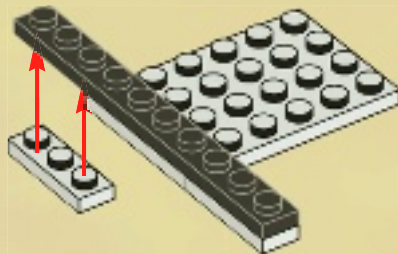

3

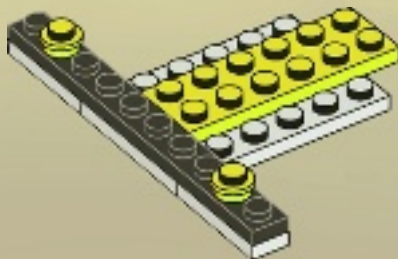

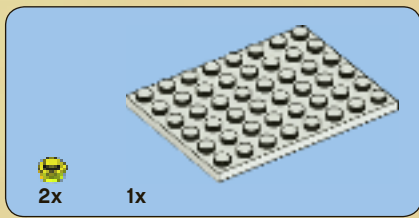

4

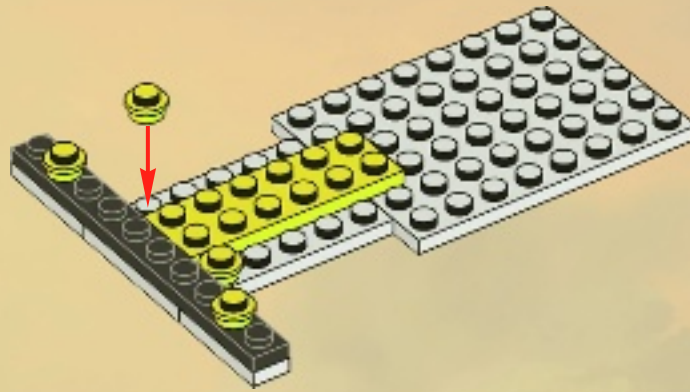

5

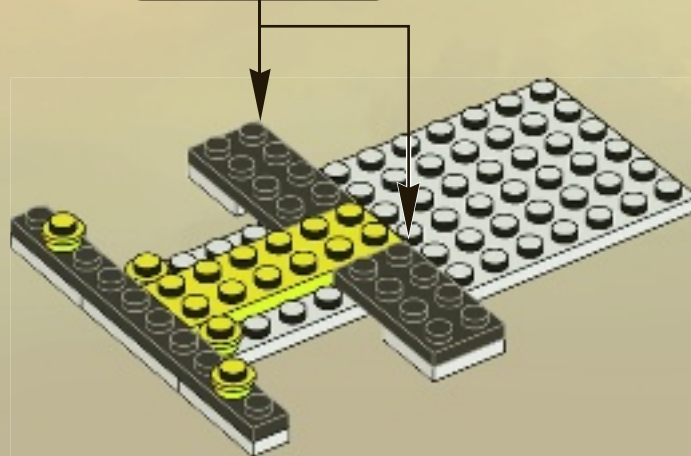
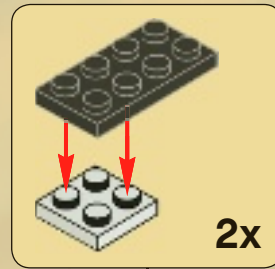



6

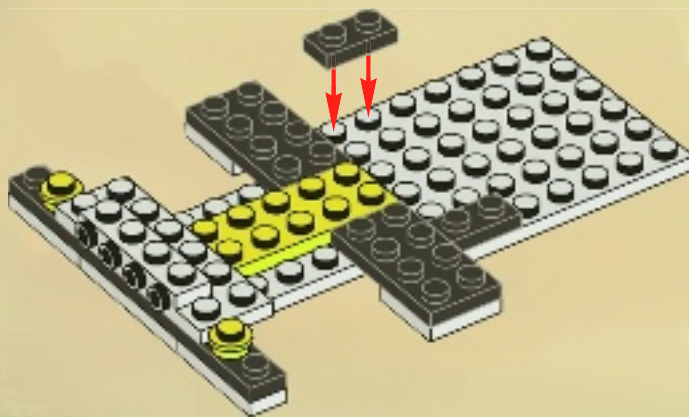





2x

7

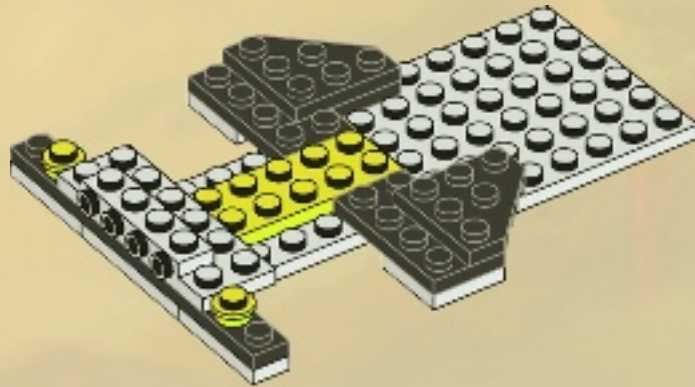

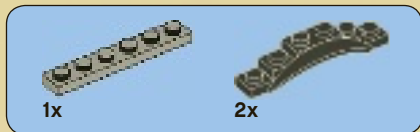

8

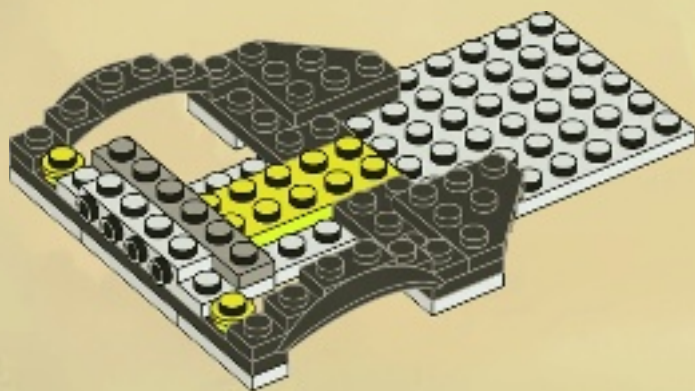



2x

9

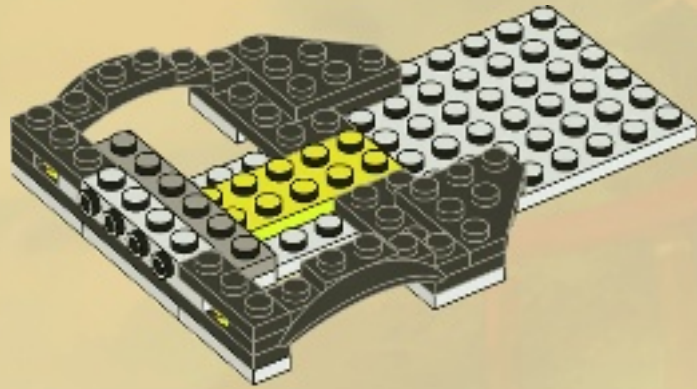



10

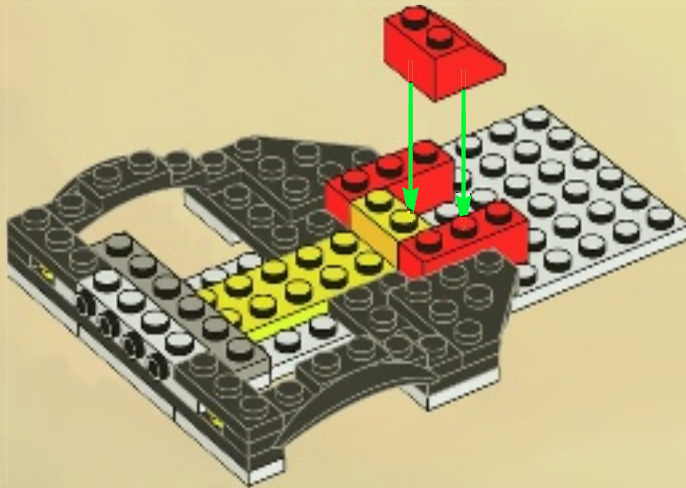





4x

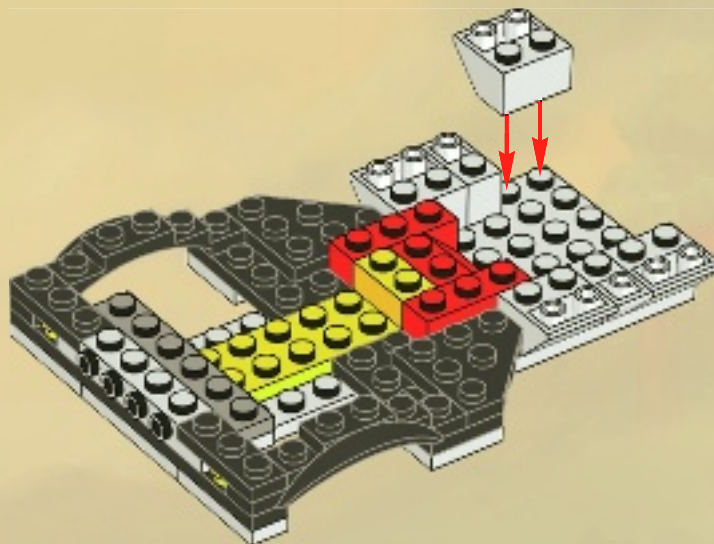

2x

# 11



1x  2x 

12

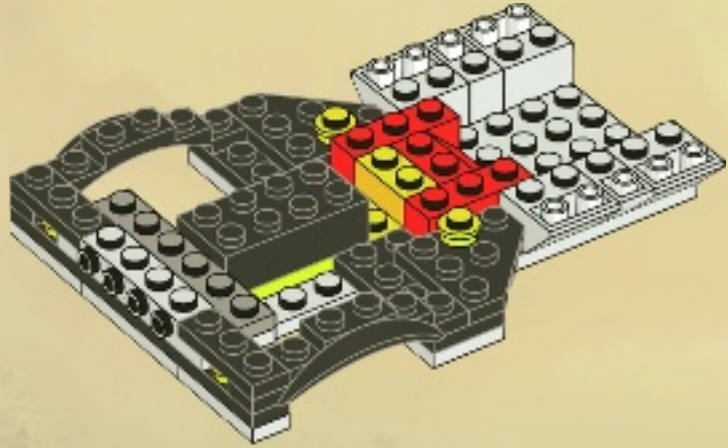



1x



1x

# 13

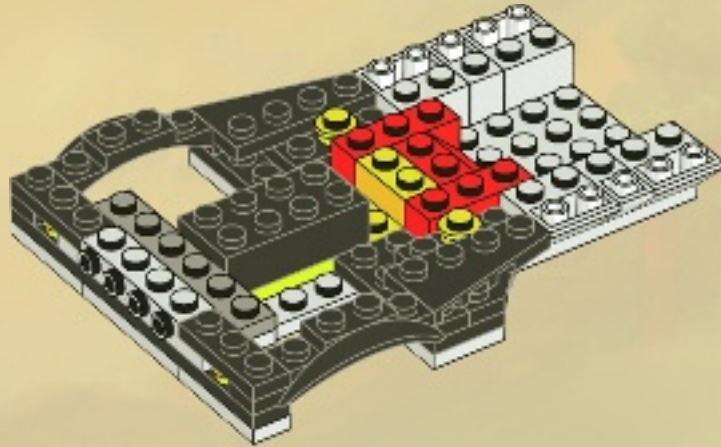

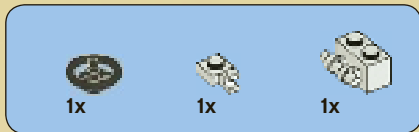

14

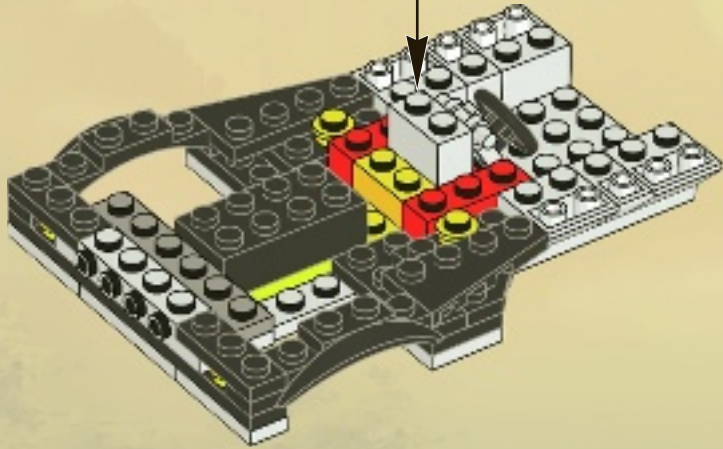
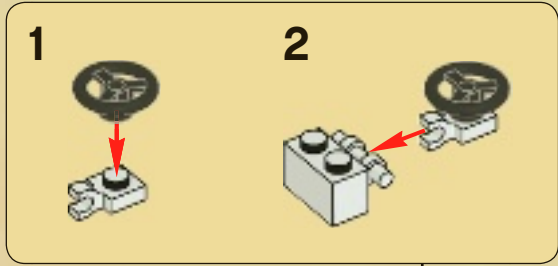





15

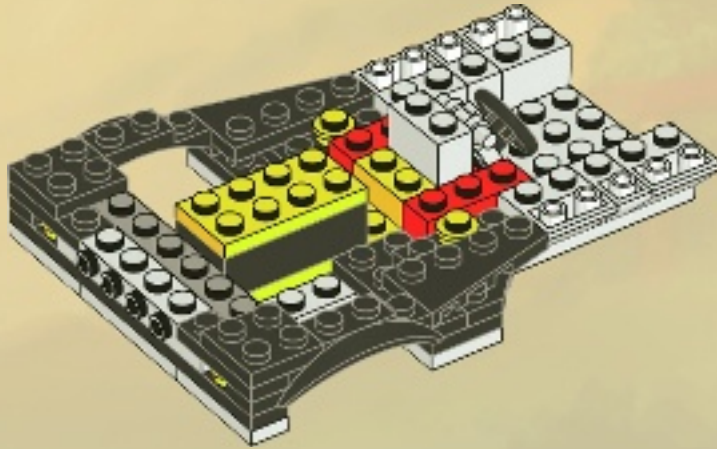

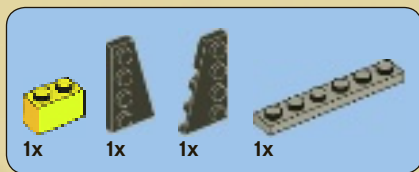

16

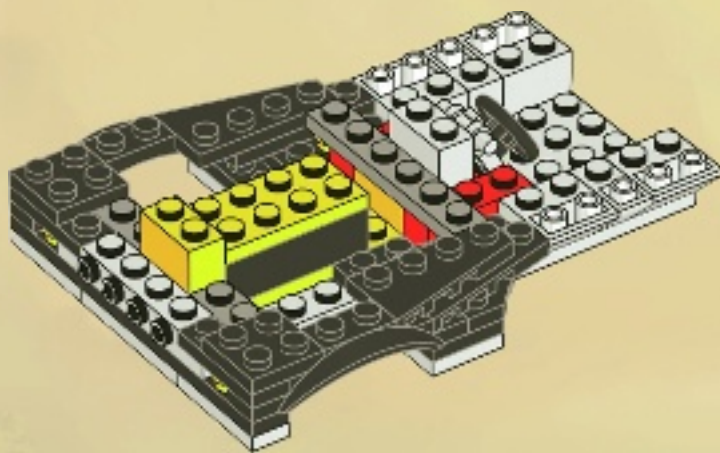

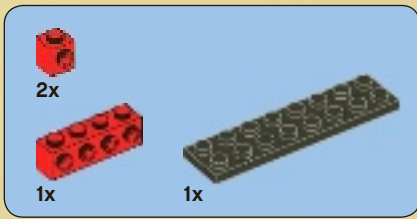

17

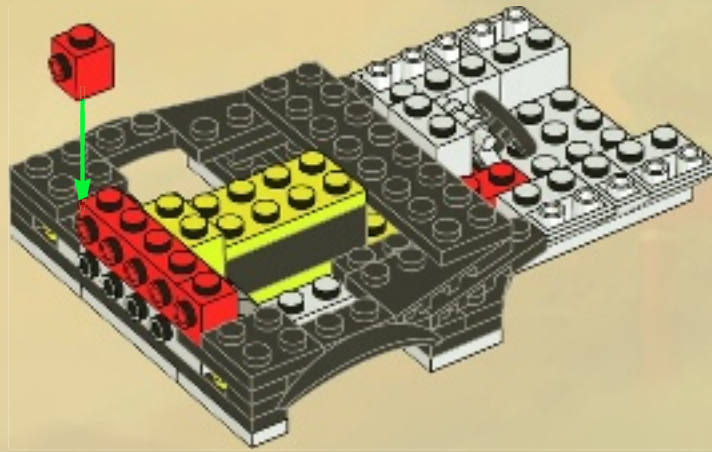

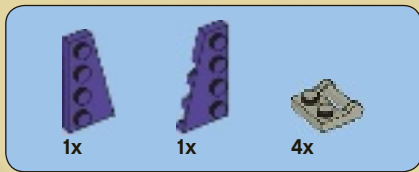

18

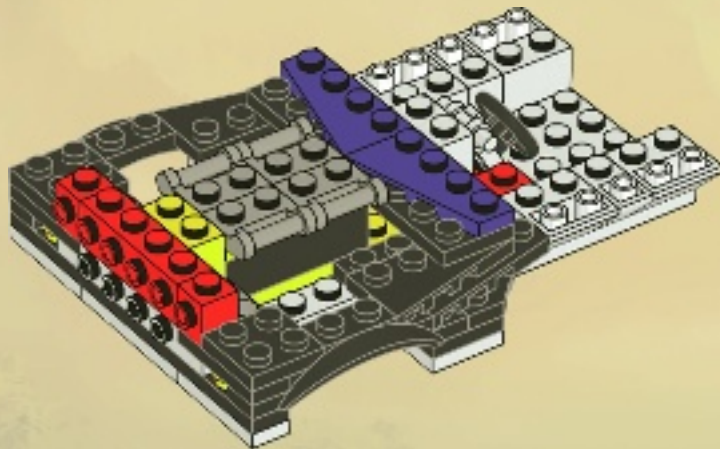



8x



8x

# 19

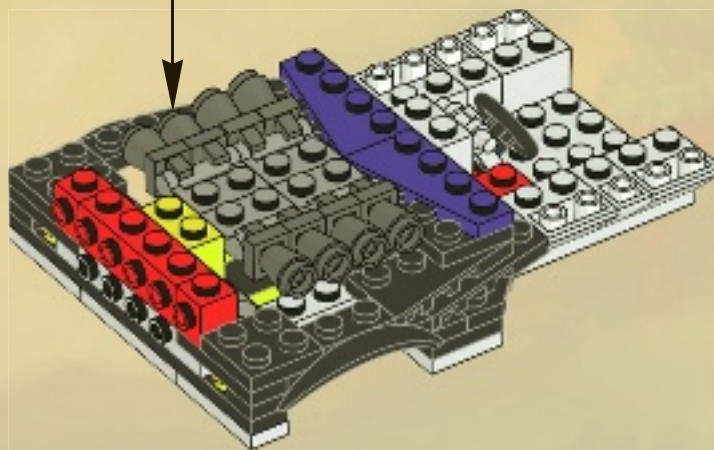
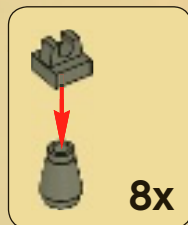

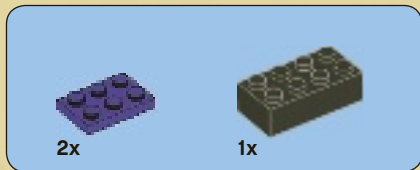

20

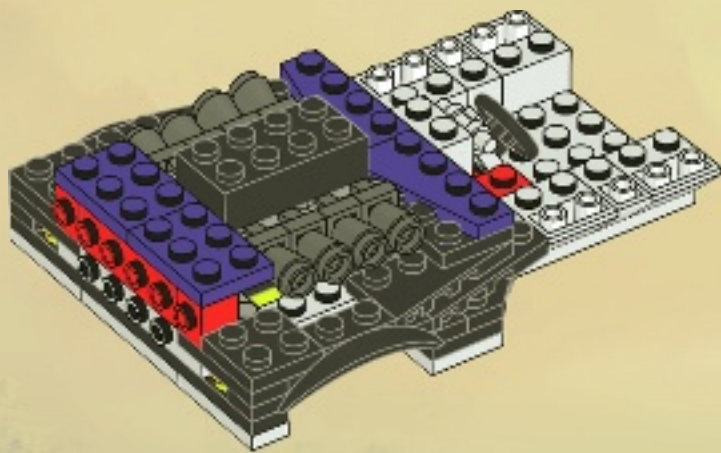

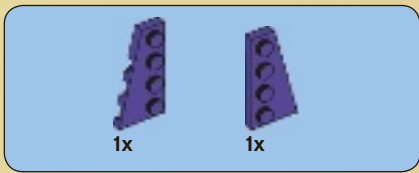

21

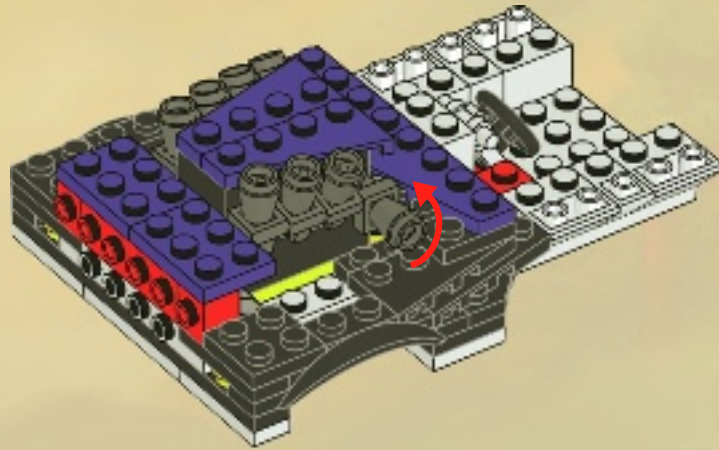

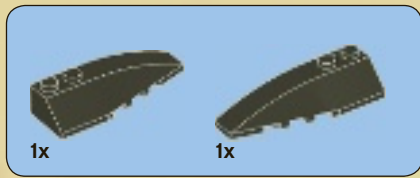

22







2x



2x

# 23

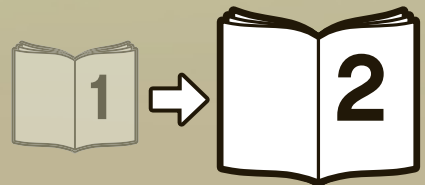





# NINJAGO

Masters of Spinjitzu



[NINJAGO.COM](http://NINJAGO.COM)



# WIN!

Go to [www.LEGOsurvey.com/product](http://www.LEGOsurvey.com/product) to fill out a survey for a chance to win a cool LEGO® Product. No purchase necessary. Open to all residents where not prohibited.

 [www.LEGO.com](http://www.LEGO.com)



## [www.LEGOsurvey.com/product](http://www.LEGOsurvey.com/product)

### GEWINNE! WIN!

Nimm an der Umfrage auf [www.LEGOsurvey.com/product](http://www.LEGOsurvey.com/product) teil und hab die Chance ein cooles LEGO® Produkt zu gewinnen!  
Die Teilnahme am Gewinnspiel führt zu keinerlei Kaufverpflichtungen. Teilnahme in allen nicht ausgeschlossenen Ländern möglich.

Ga naar [www.LEGOsurvey.com/product](http://www.LEGOsurvey.com/product), vul een enquêteformulier in en maak kans op een cool LEGO® product.  
Geen aankoopverplichting. Iedereen mag deelnemen, uitgezonderd ingezetenden van landen waar een enquêteverbod geldt.

### GAGNE! 当てよう!

Visite [www.LEGOsurvey.com/product](http://www.LEGOsurvey.com/product) pour répondre à un questionnaire et avoir une chance de gagner un produit LEGO® très cool!  
Aucune obligation d'achat. Ouvert à tous les résidents des pays autorisés.

[www.LEGOsurvey.com/product](http://www.LEGOsurvey.com/product) にアクセスして、アンケートにご記入ください。当選者にはレゴ®製品を差し上げます。  
お買い上げの必要はありません。  
禁止されていない限り、すべての皆様にご利用いただけます。