



# TECHNIC

42000



1



2



3



4



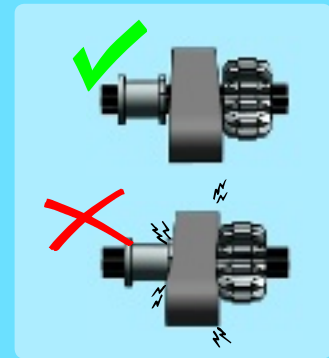
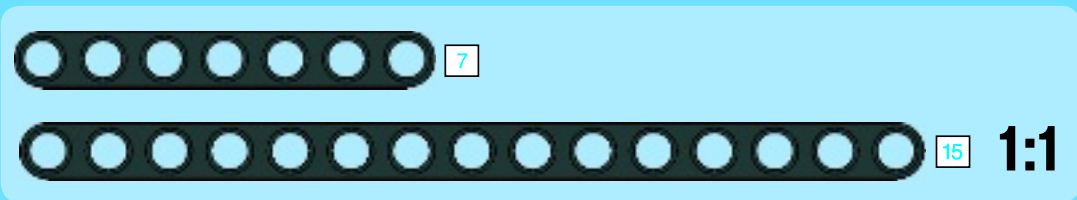

1



2

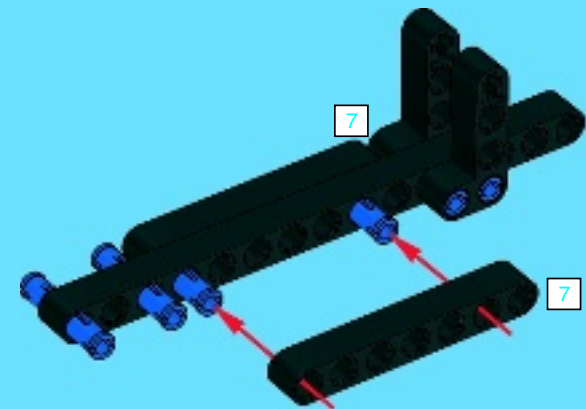



3

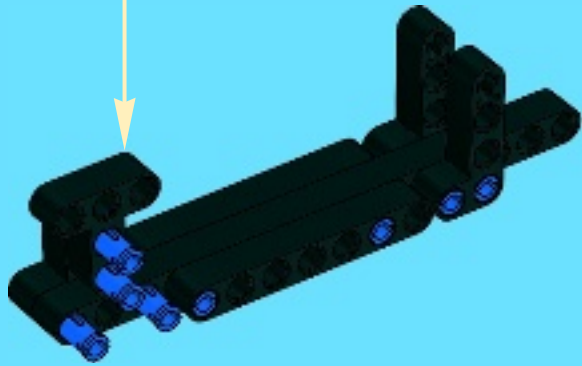
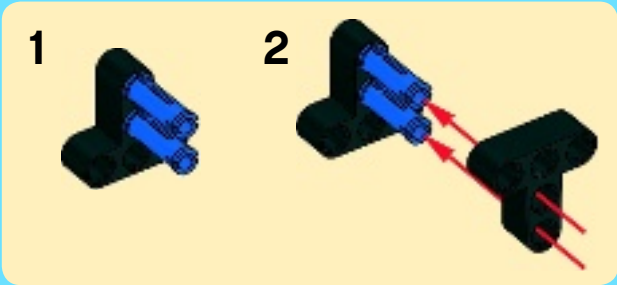

4

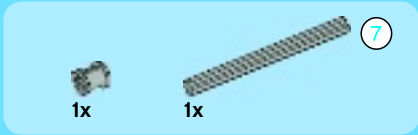
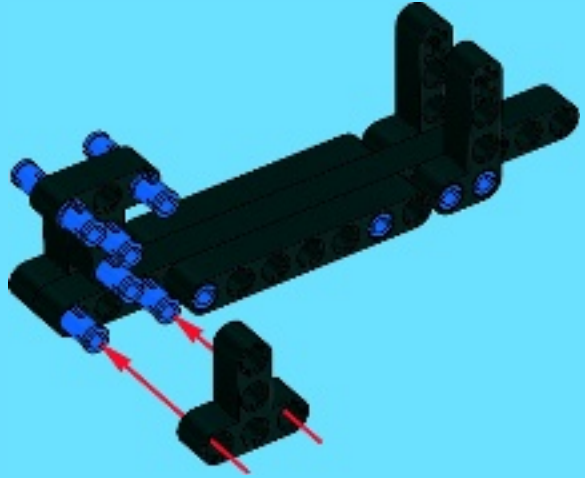

5

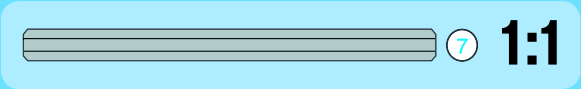
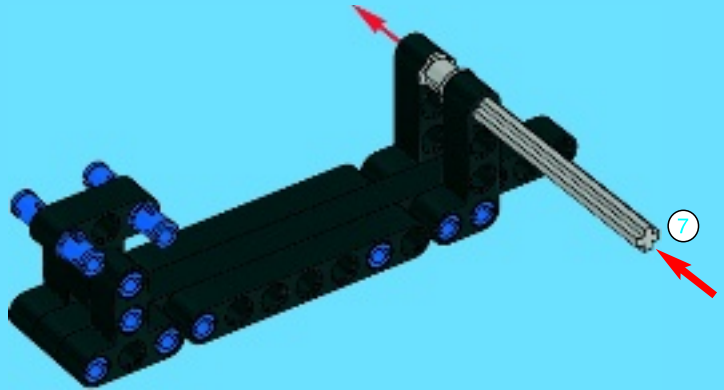

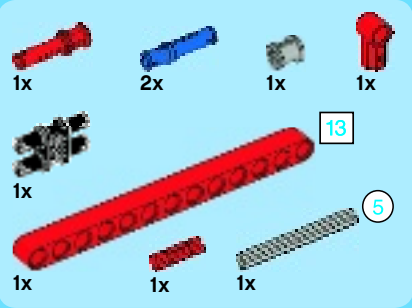

# 6

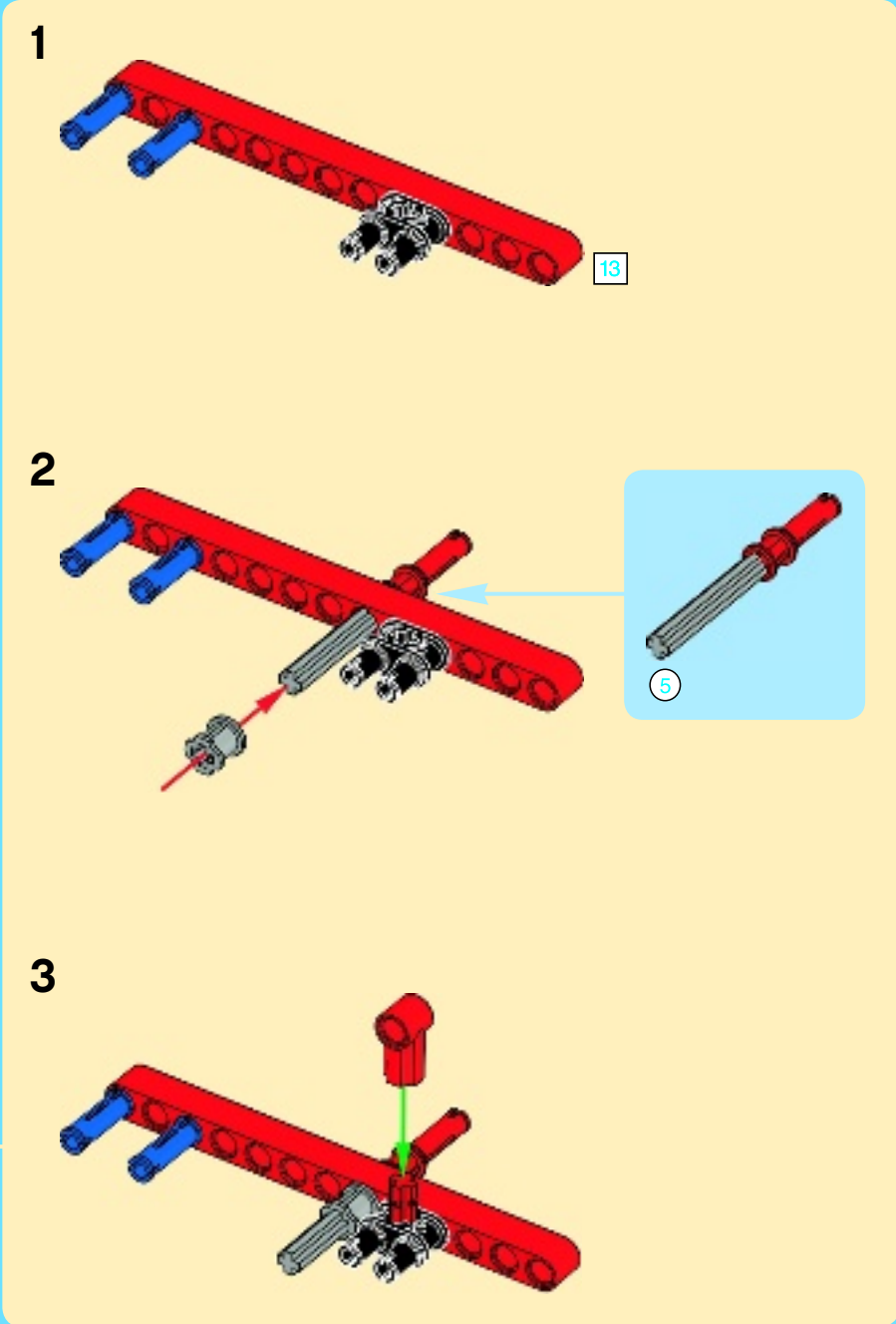
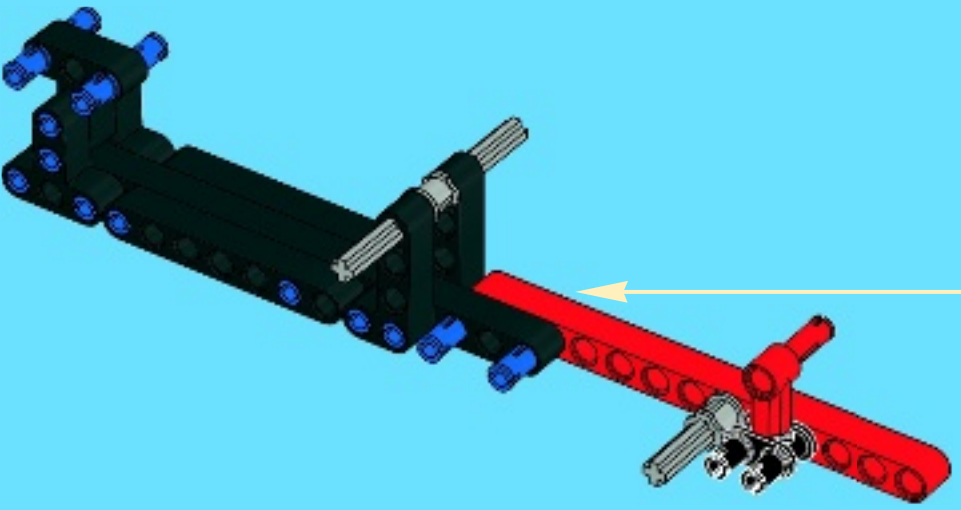



7

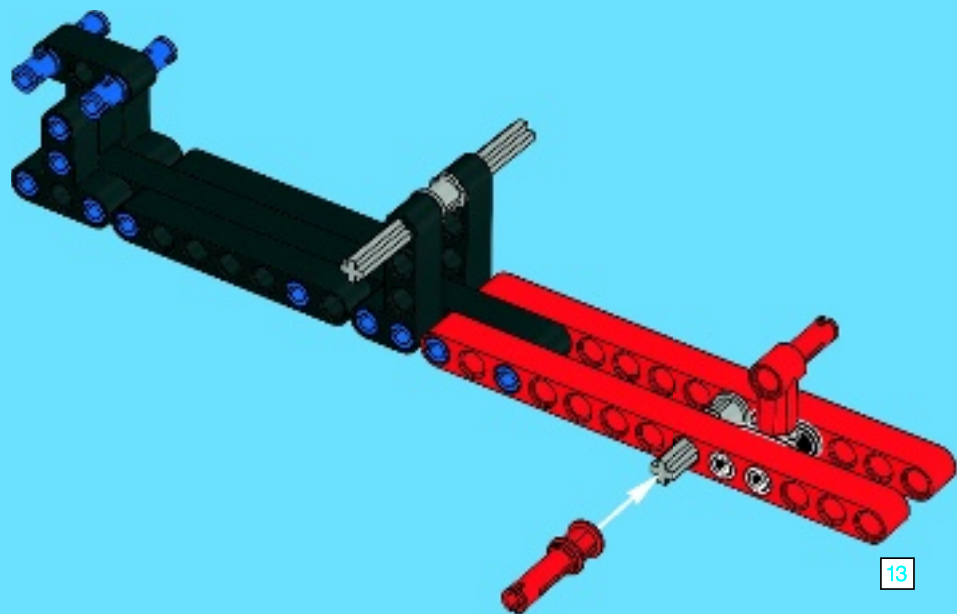
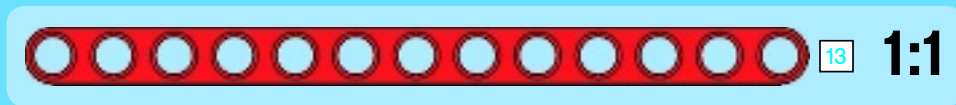

8

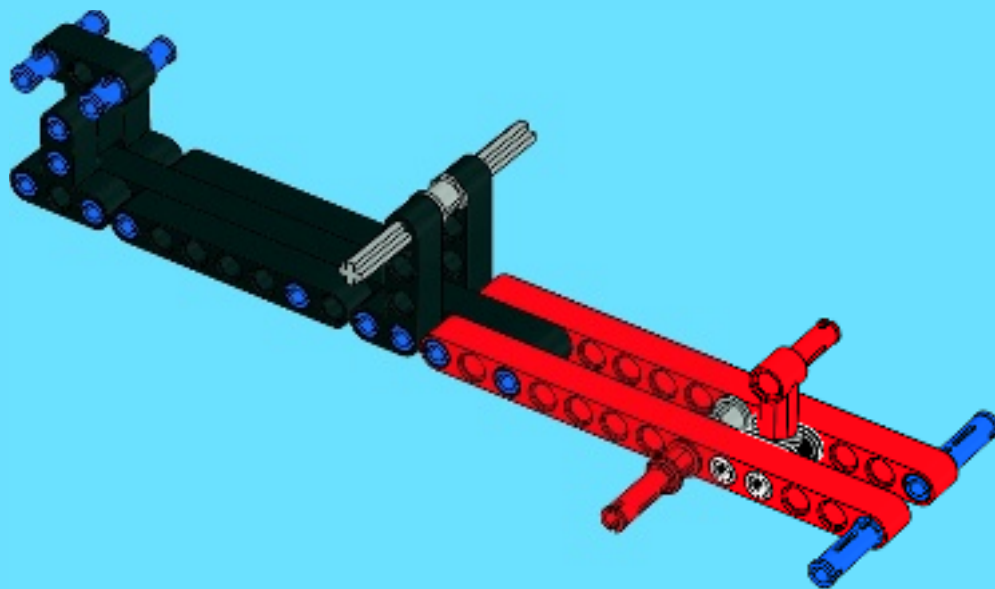

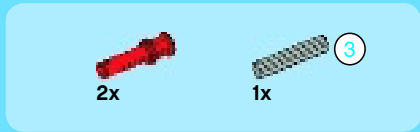
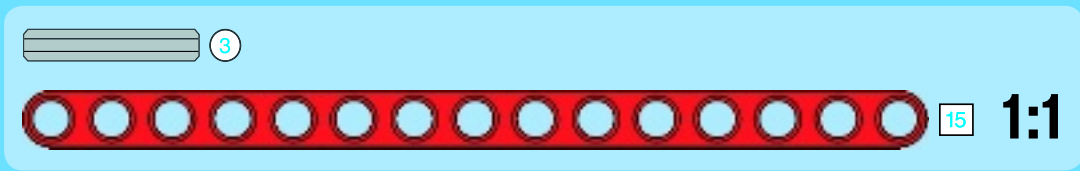

1

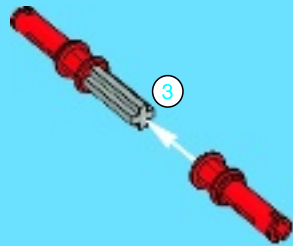

2

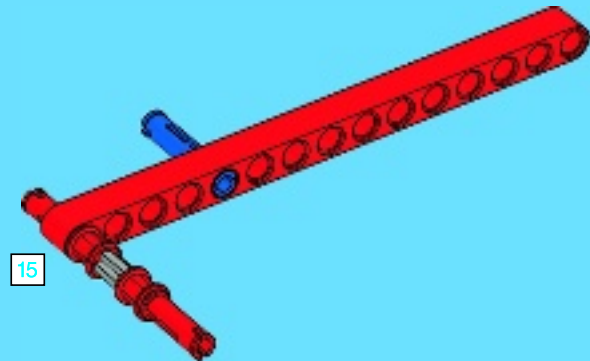

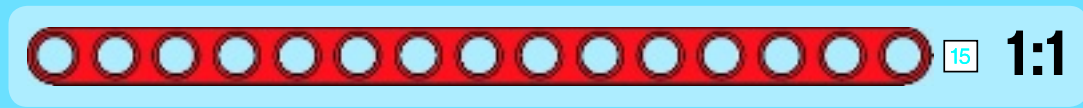

3

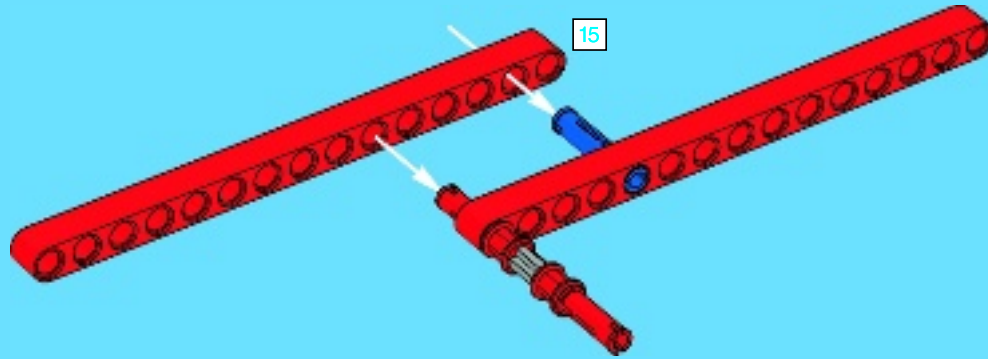

4

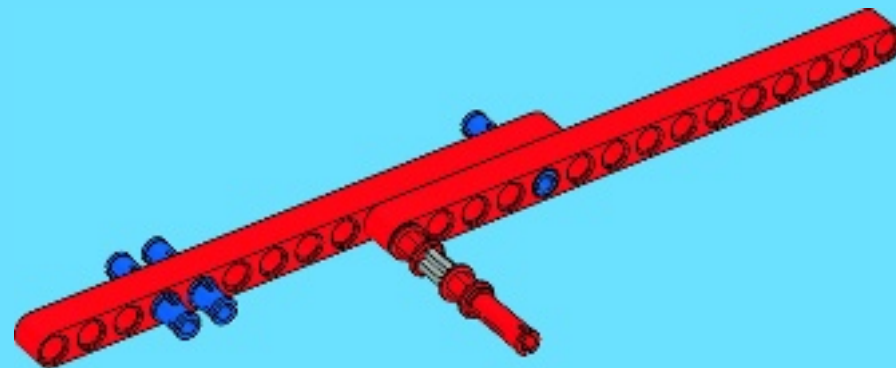



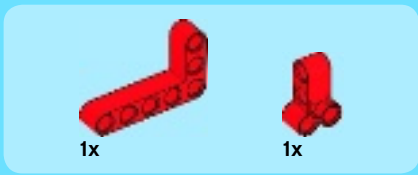

5

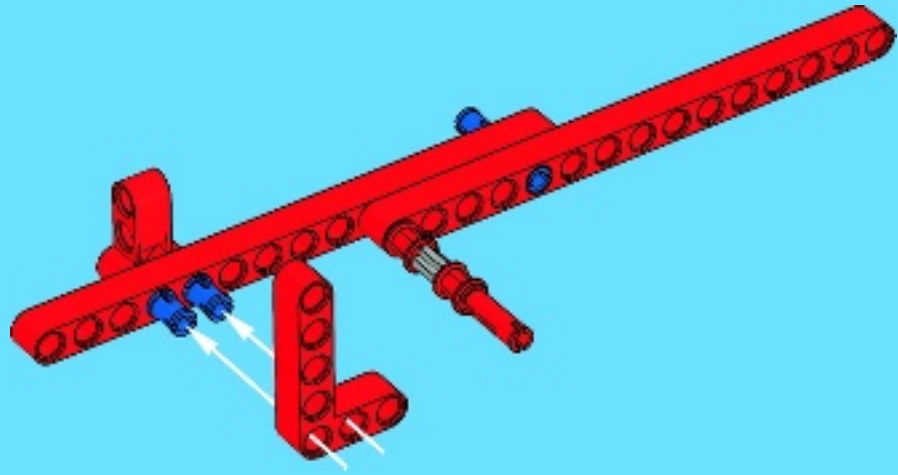

9

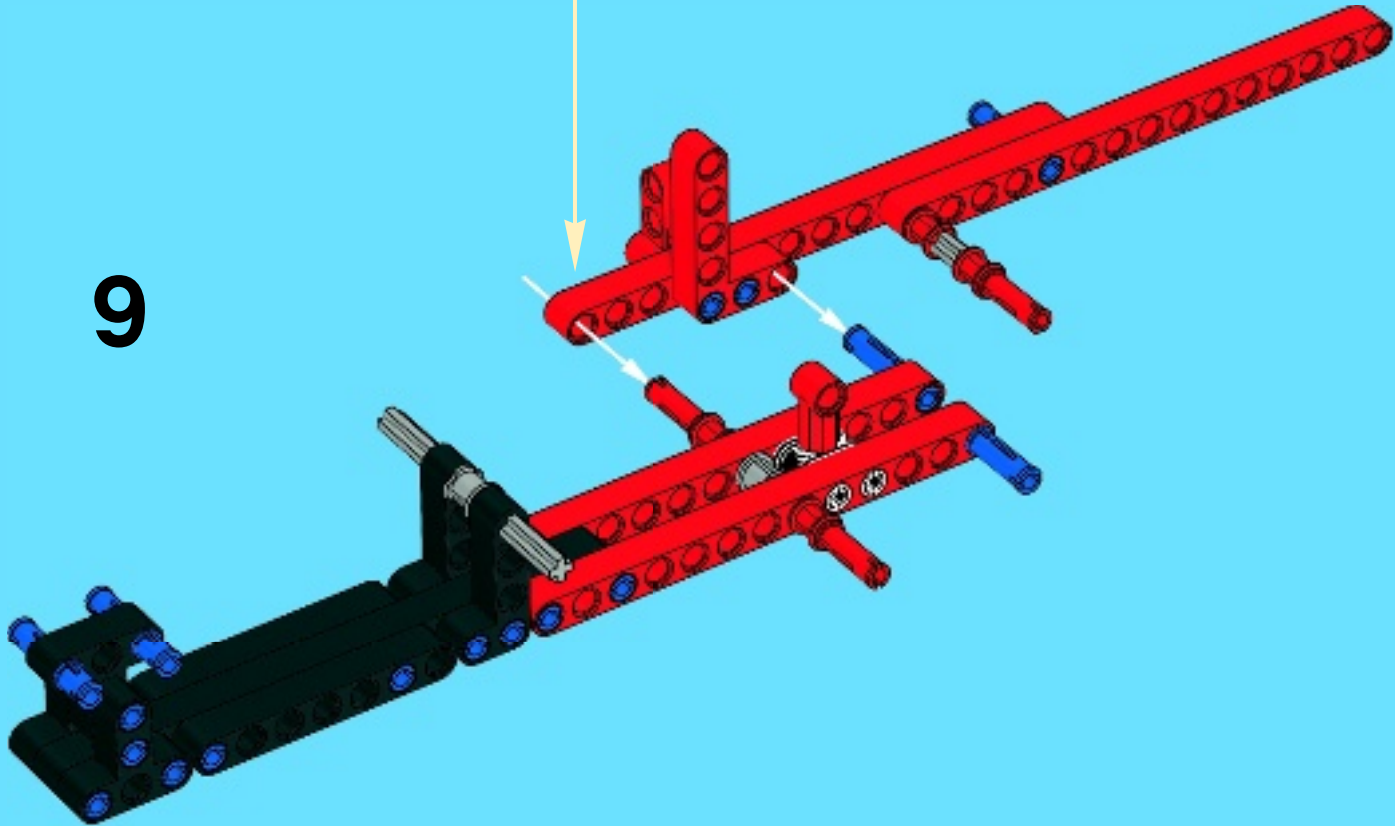

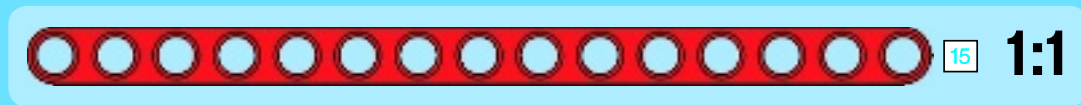

10

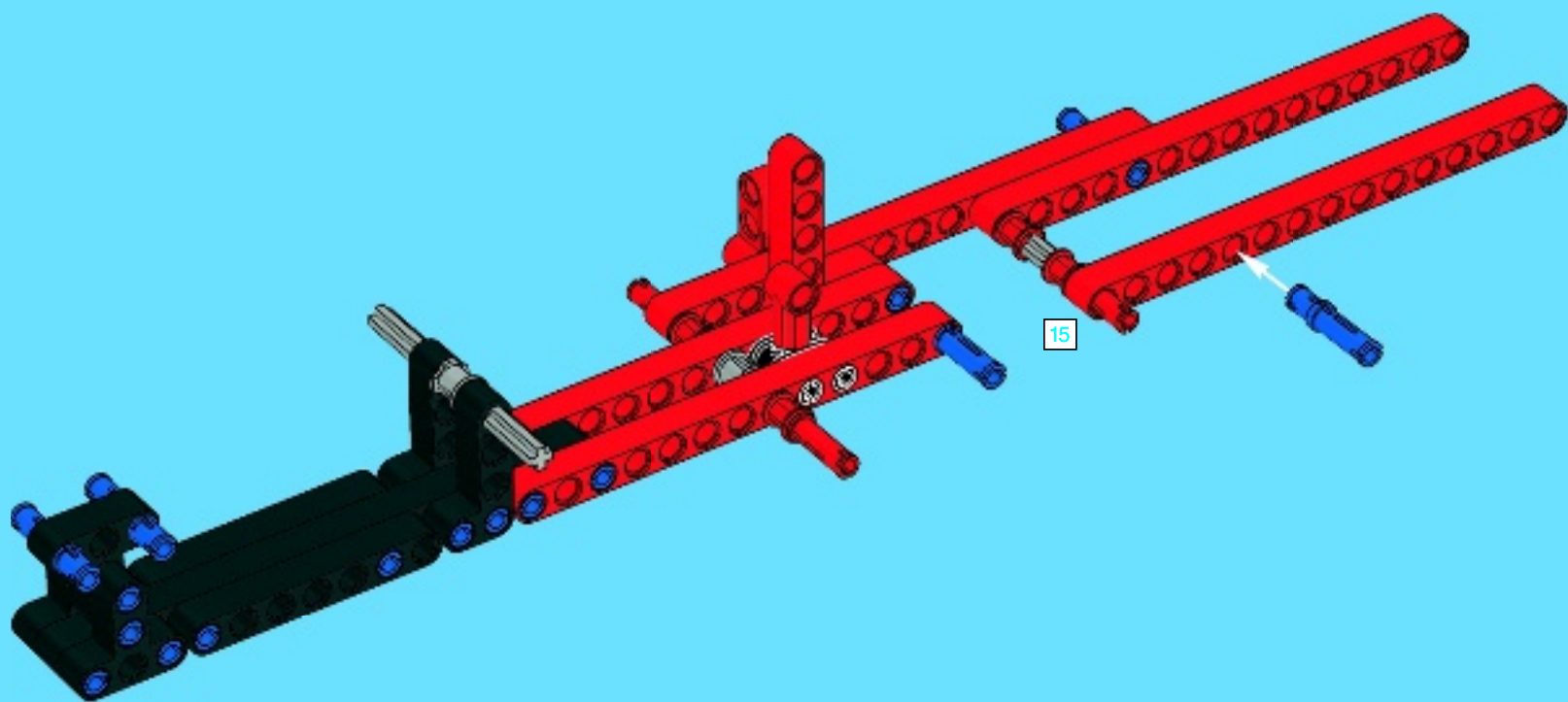

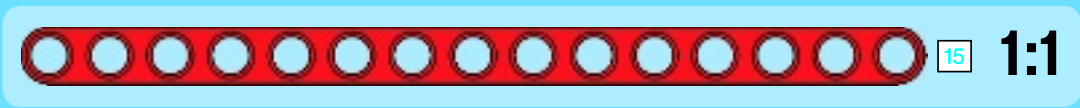
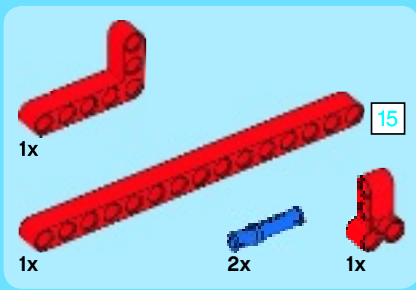

# 11

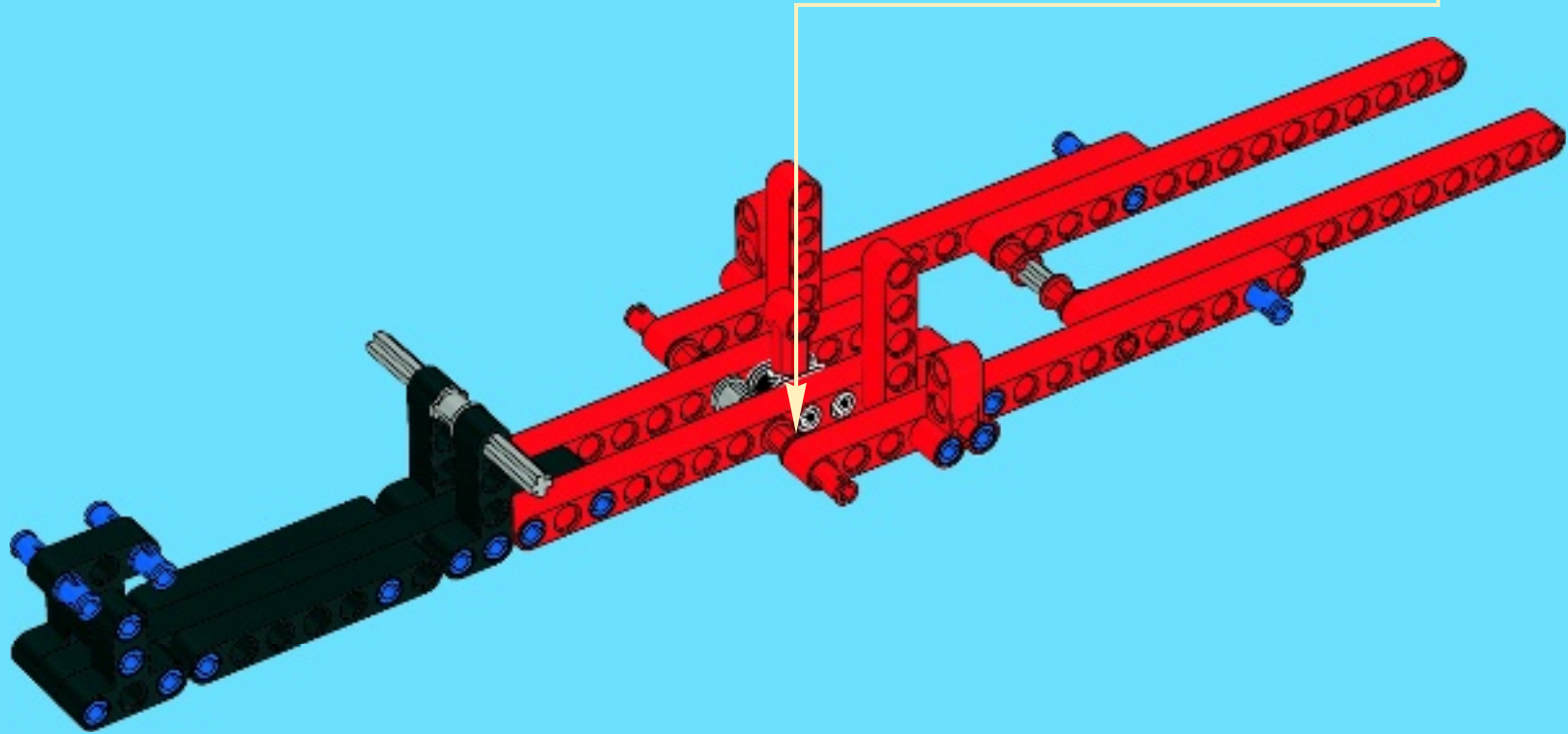
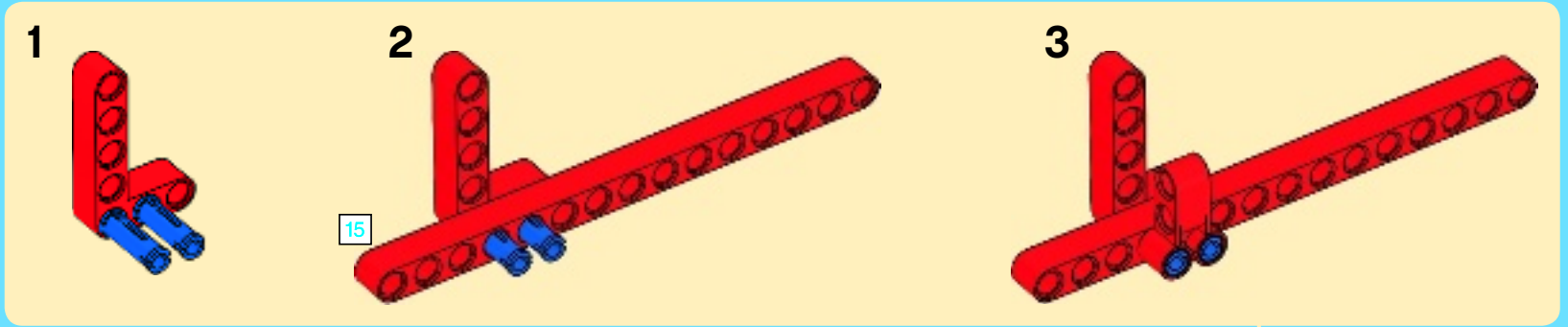



2x

# 12

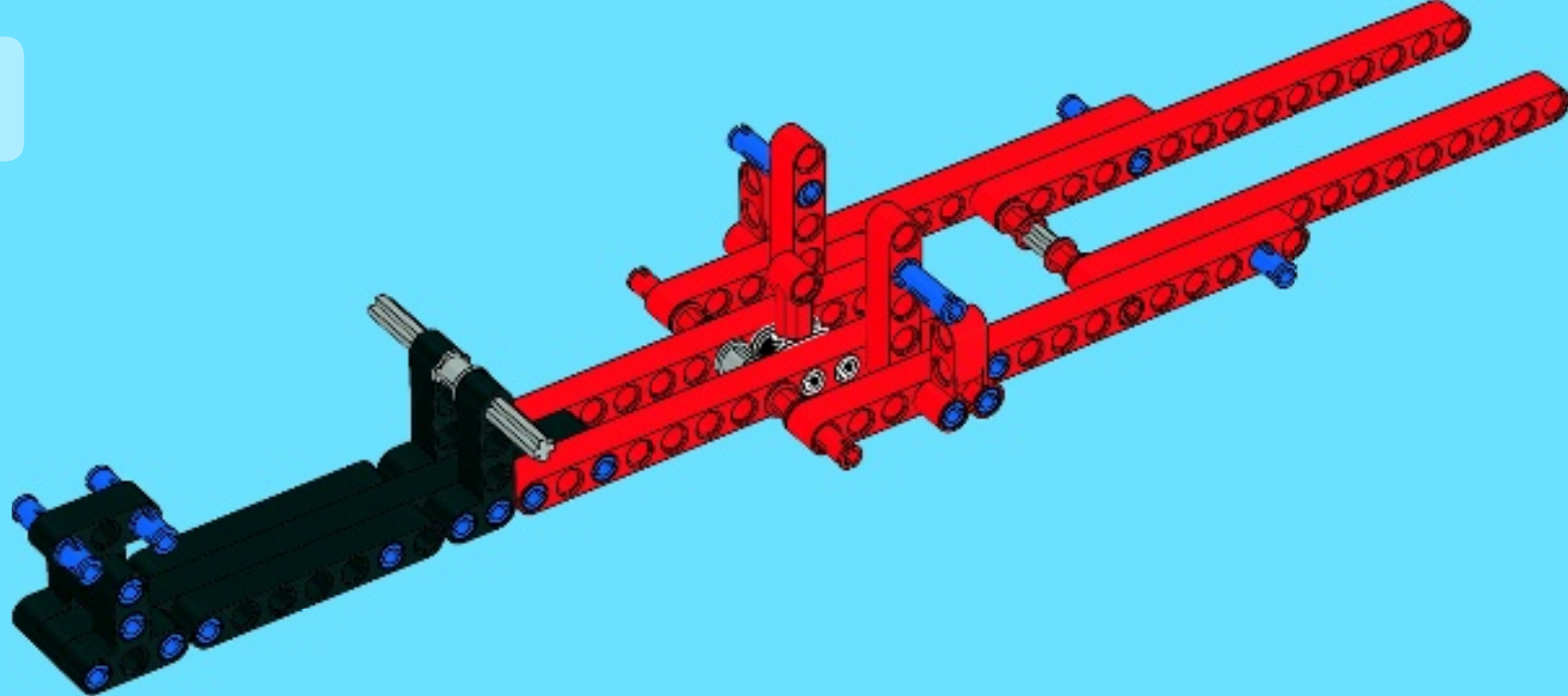

4x



4x

# 13

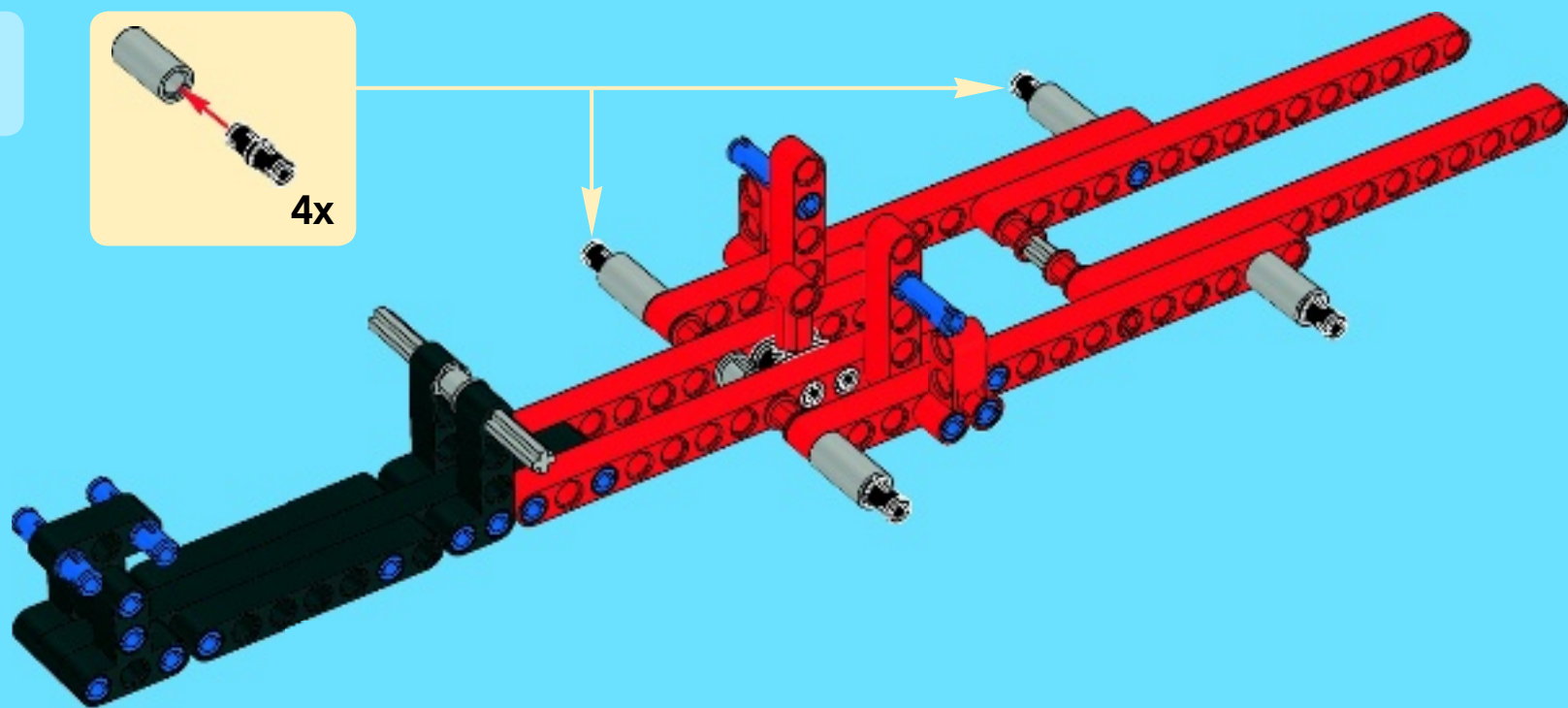
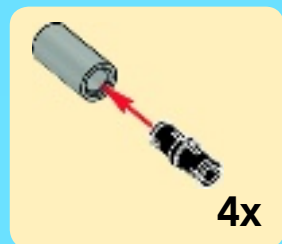

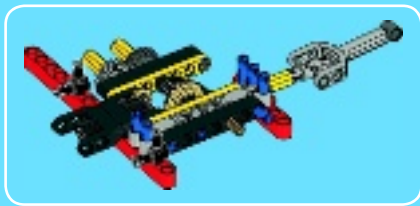

1

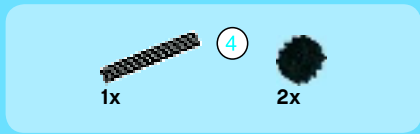
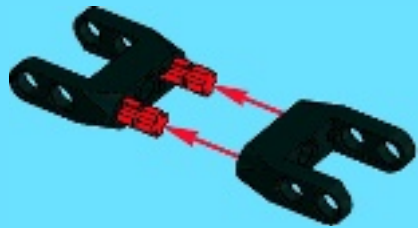

2

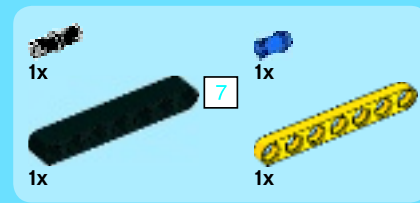
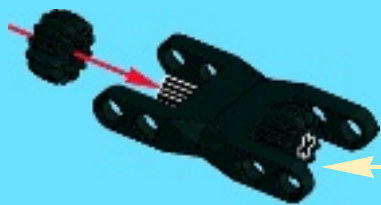

3

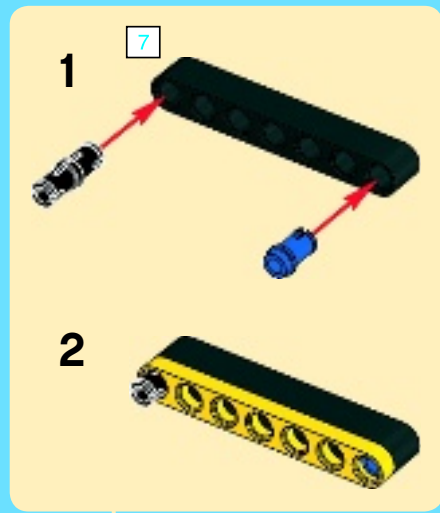

2

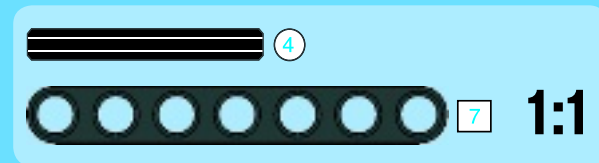
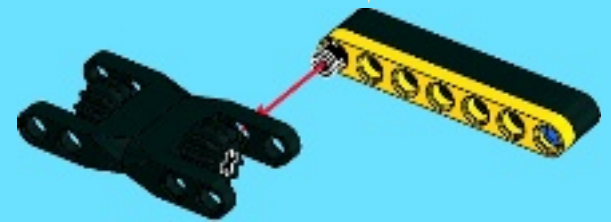

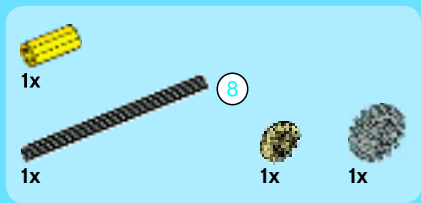

4

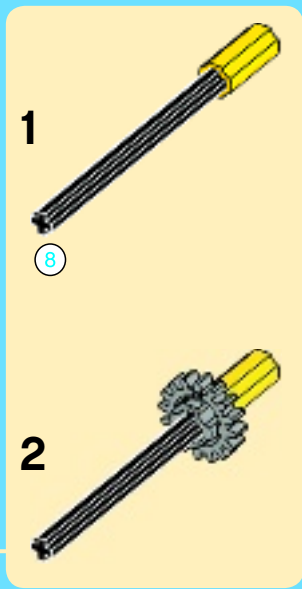
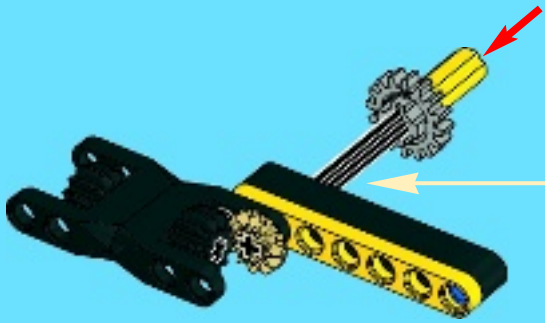

5

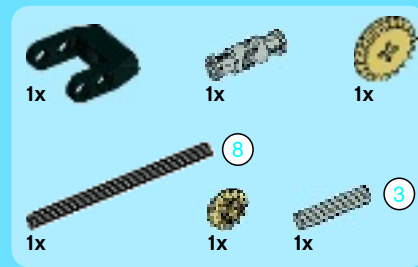
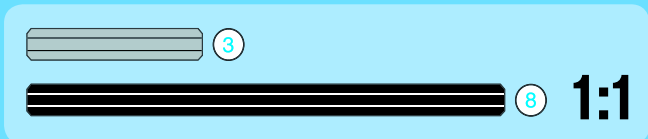

6

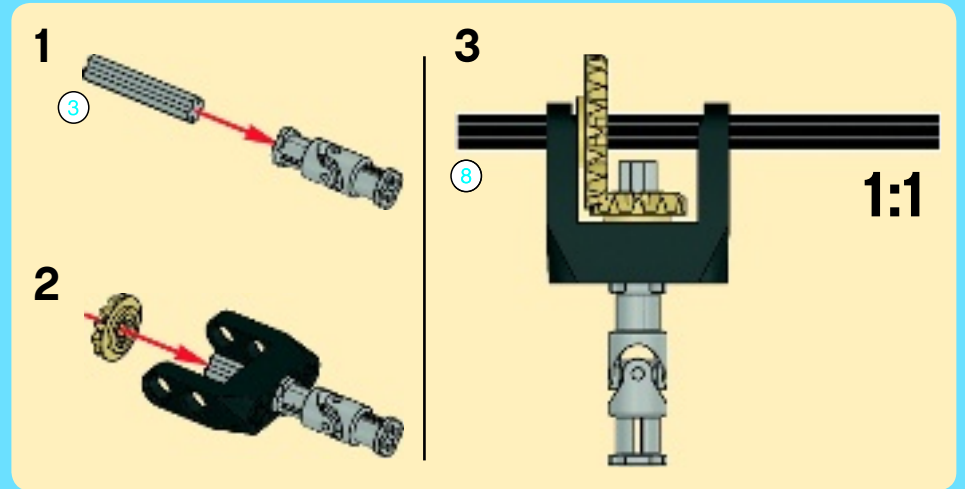



7

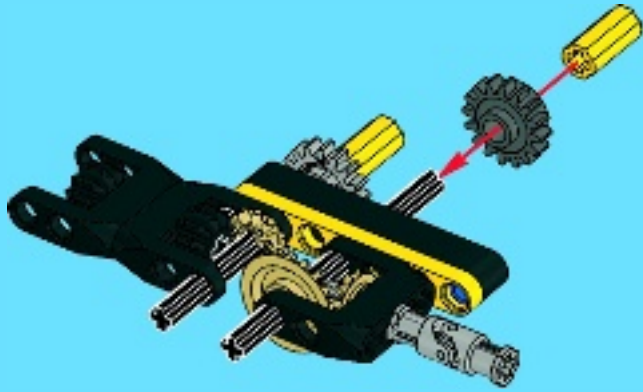

8

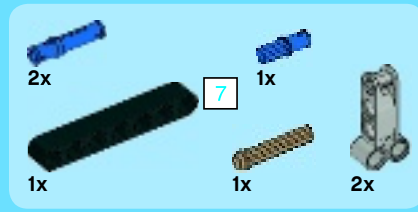
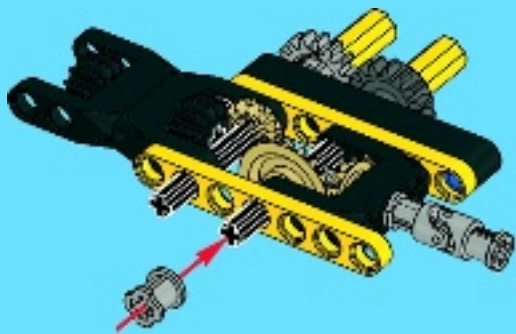

9

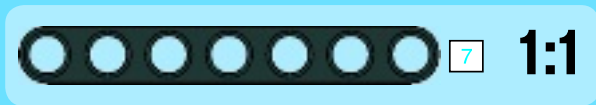
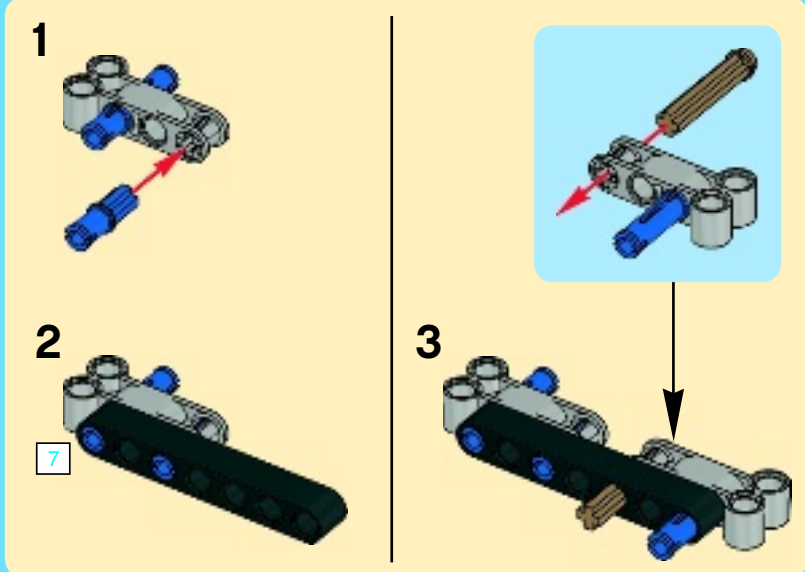

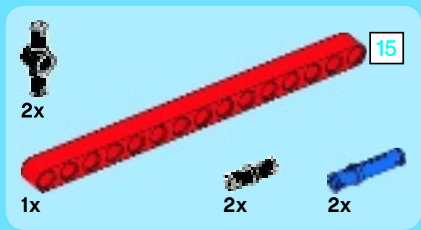

10

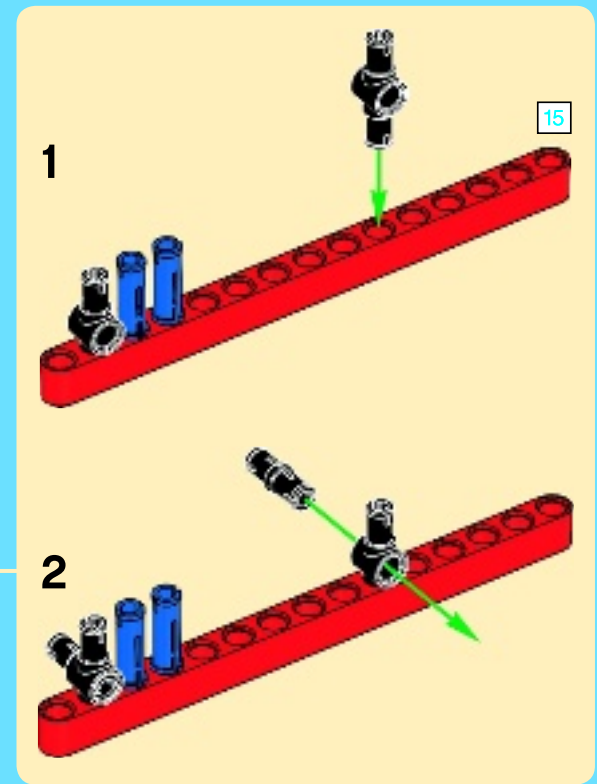
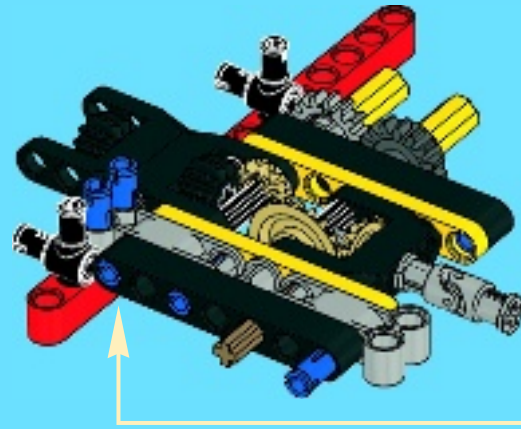

11

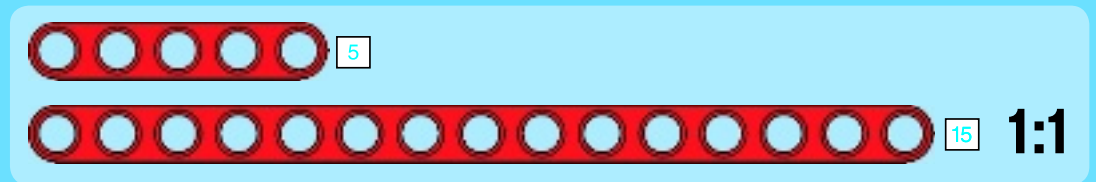
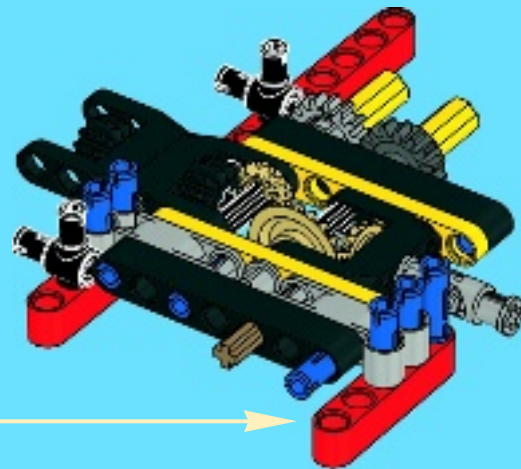
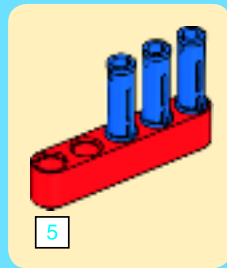



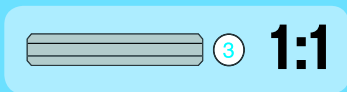
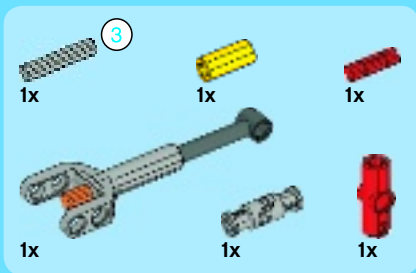

12

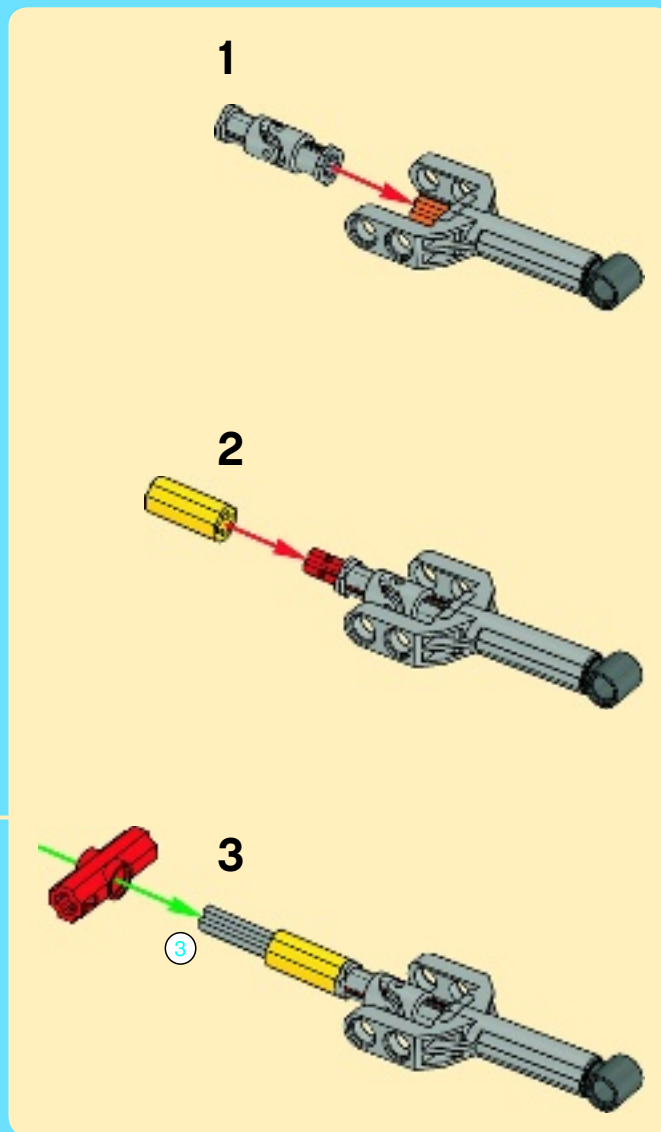
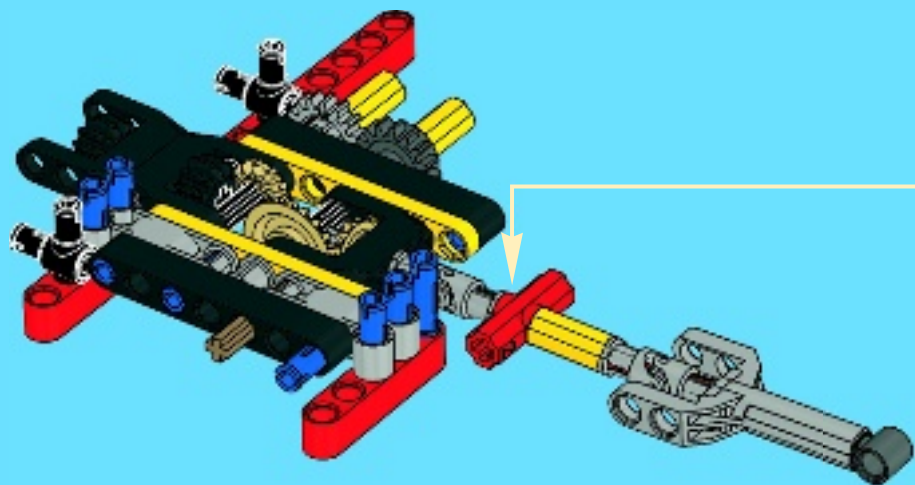



2x



2x

4

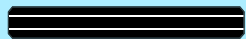

4

1:1

# 14



4

2x

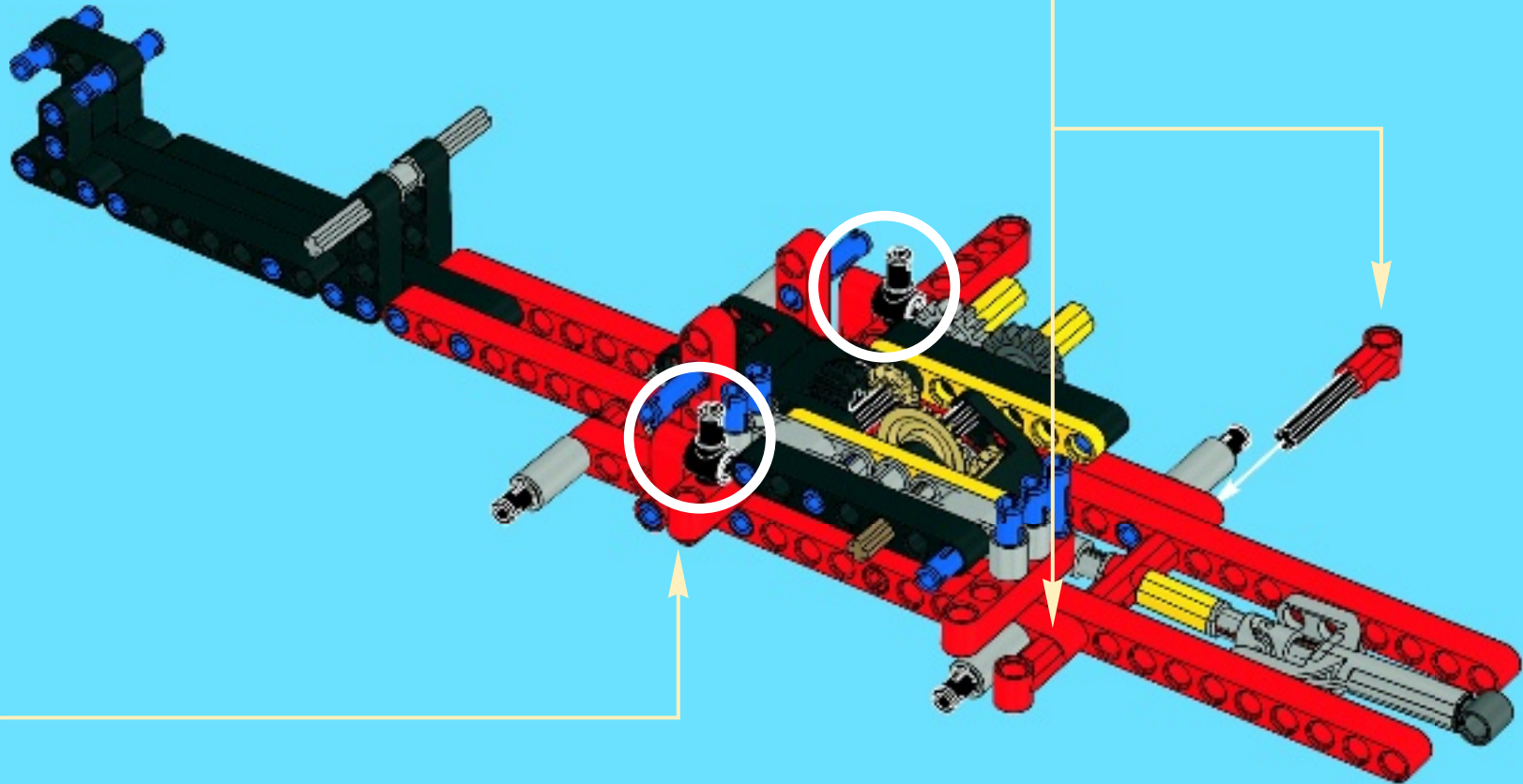



2x

# 15

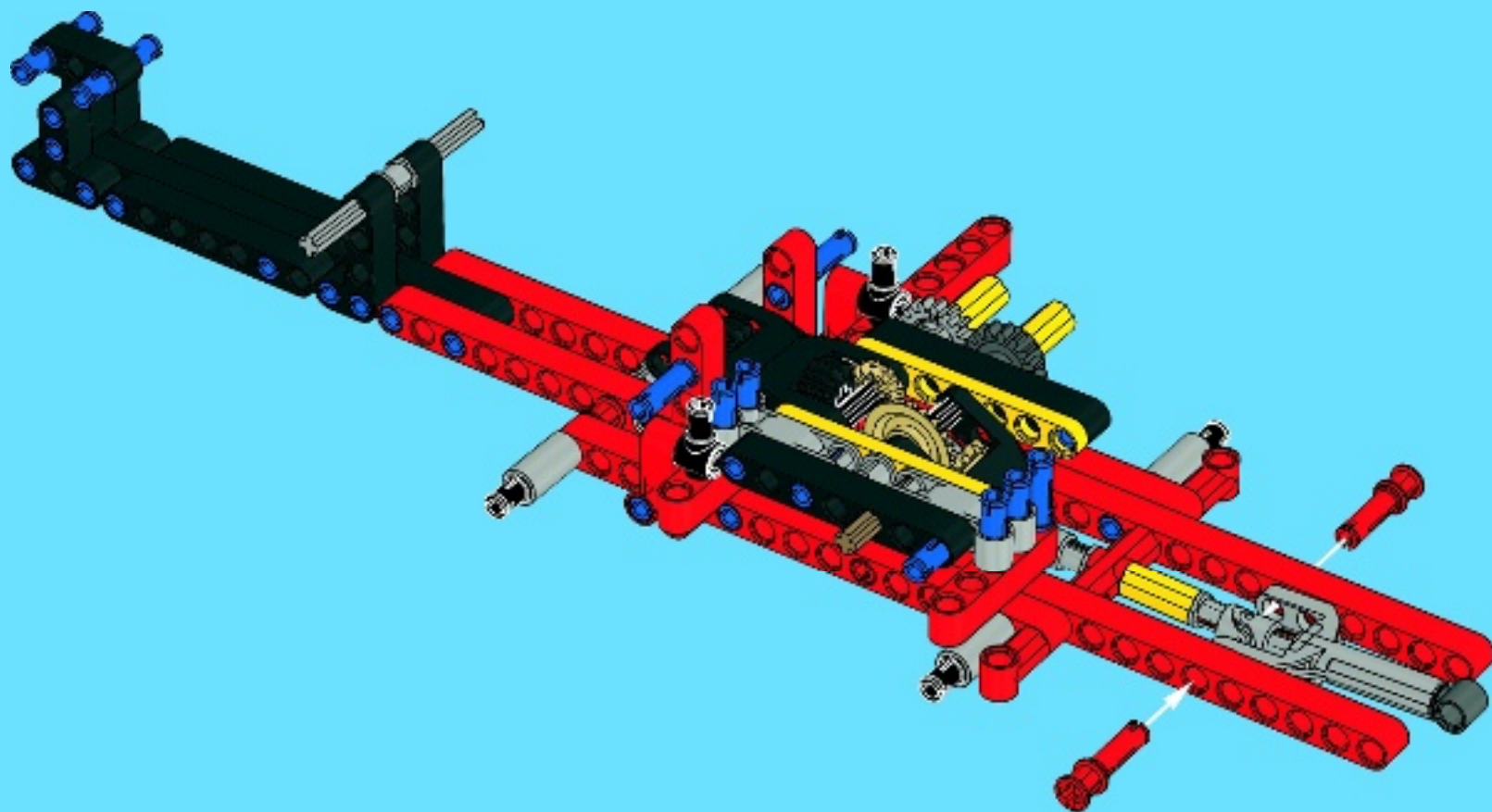

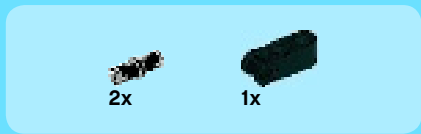
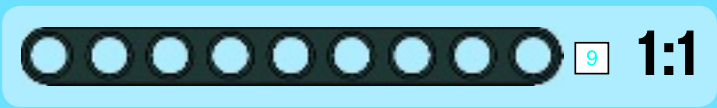

1



2



3

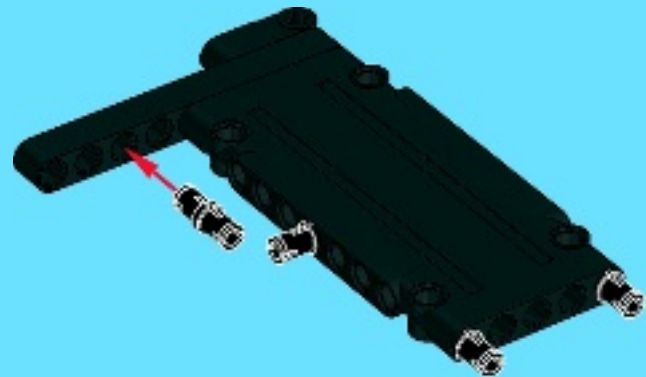

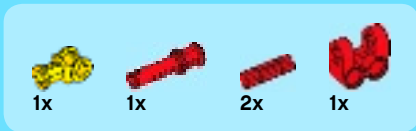

4

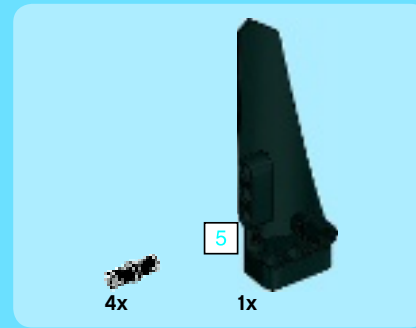
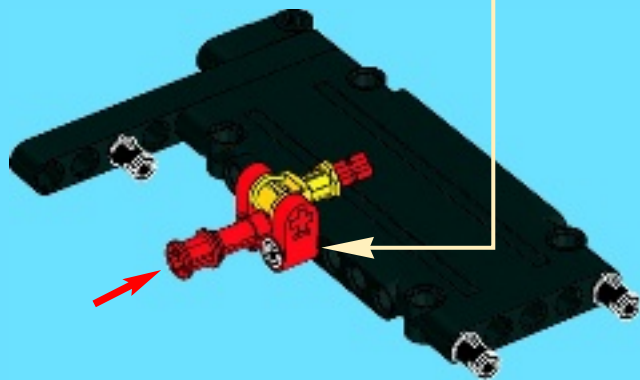
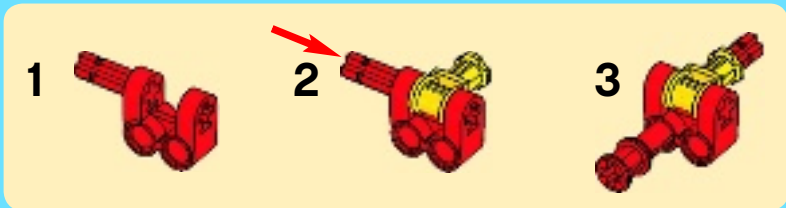

5

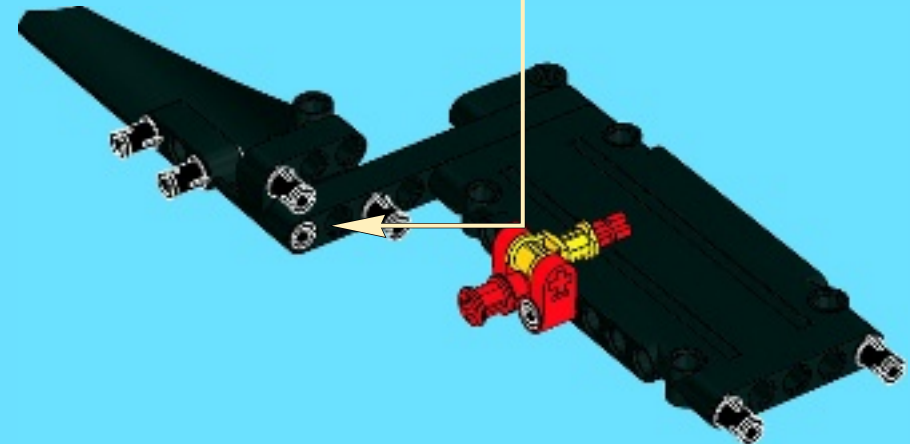
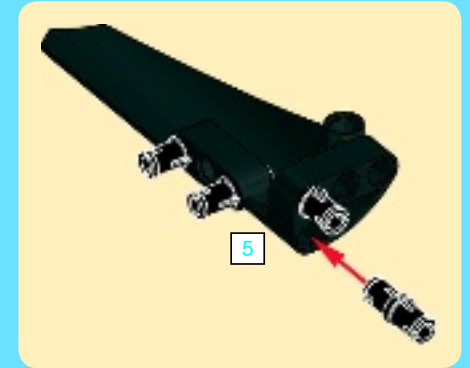



6

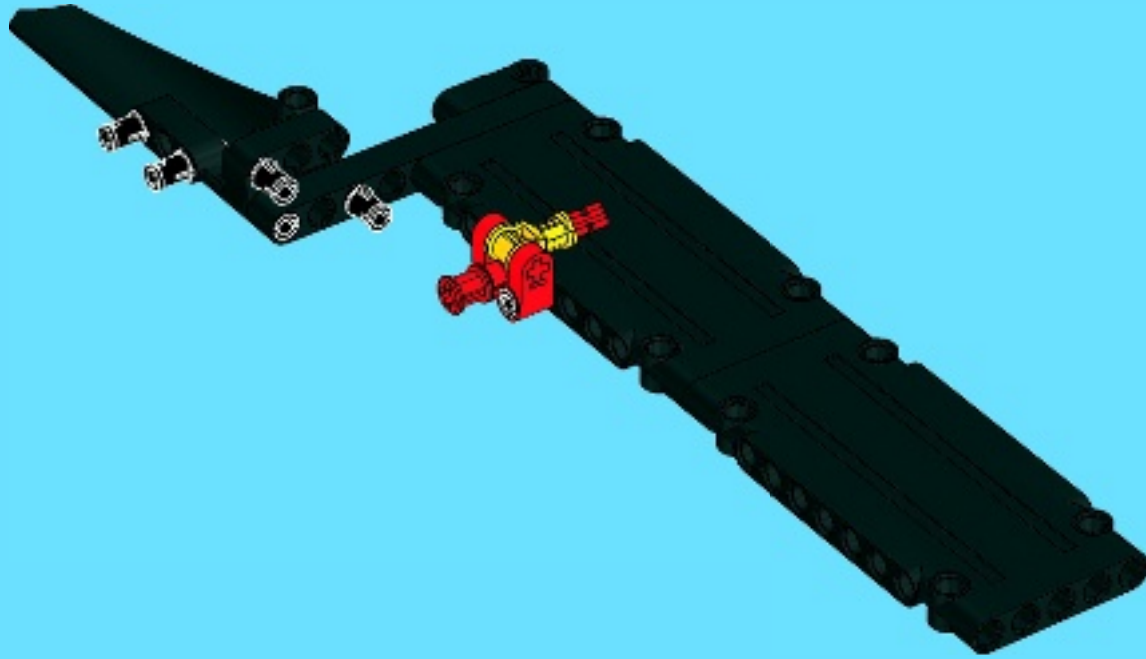

16

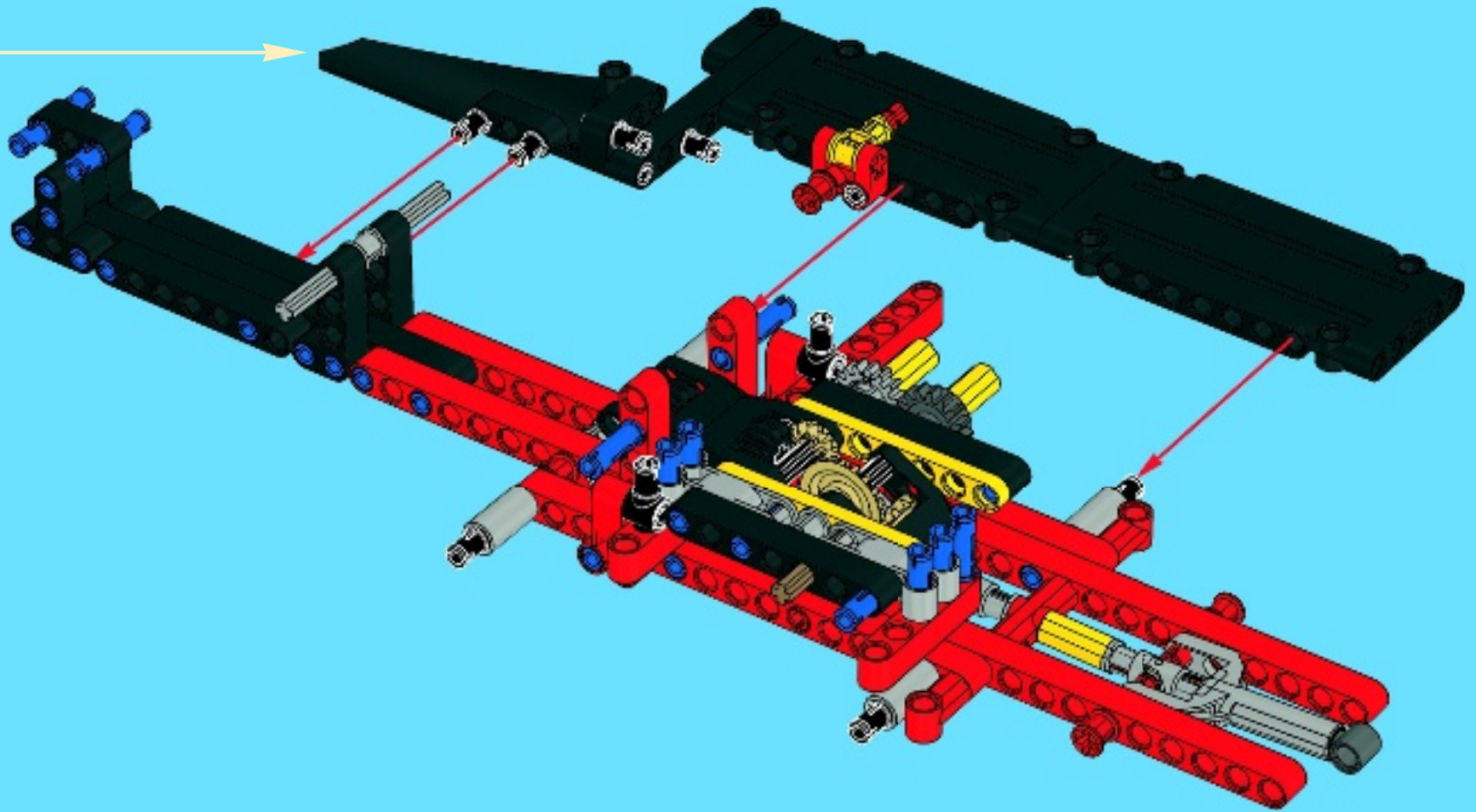

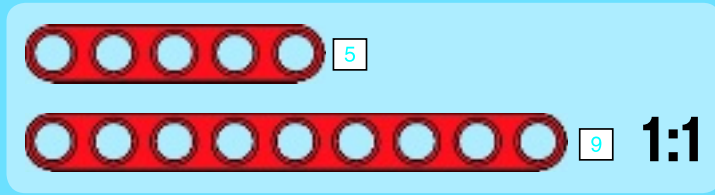
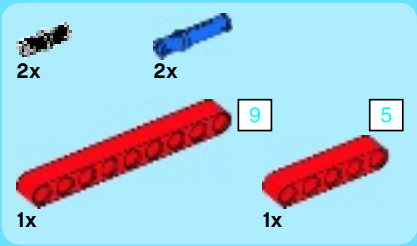

17

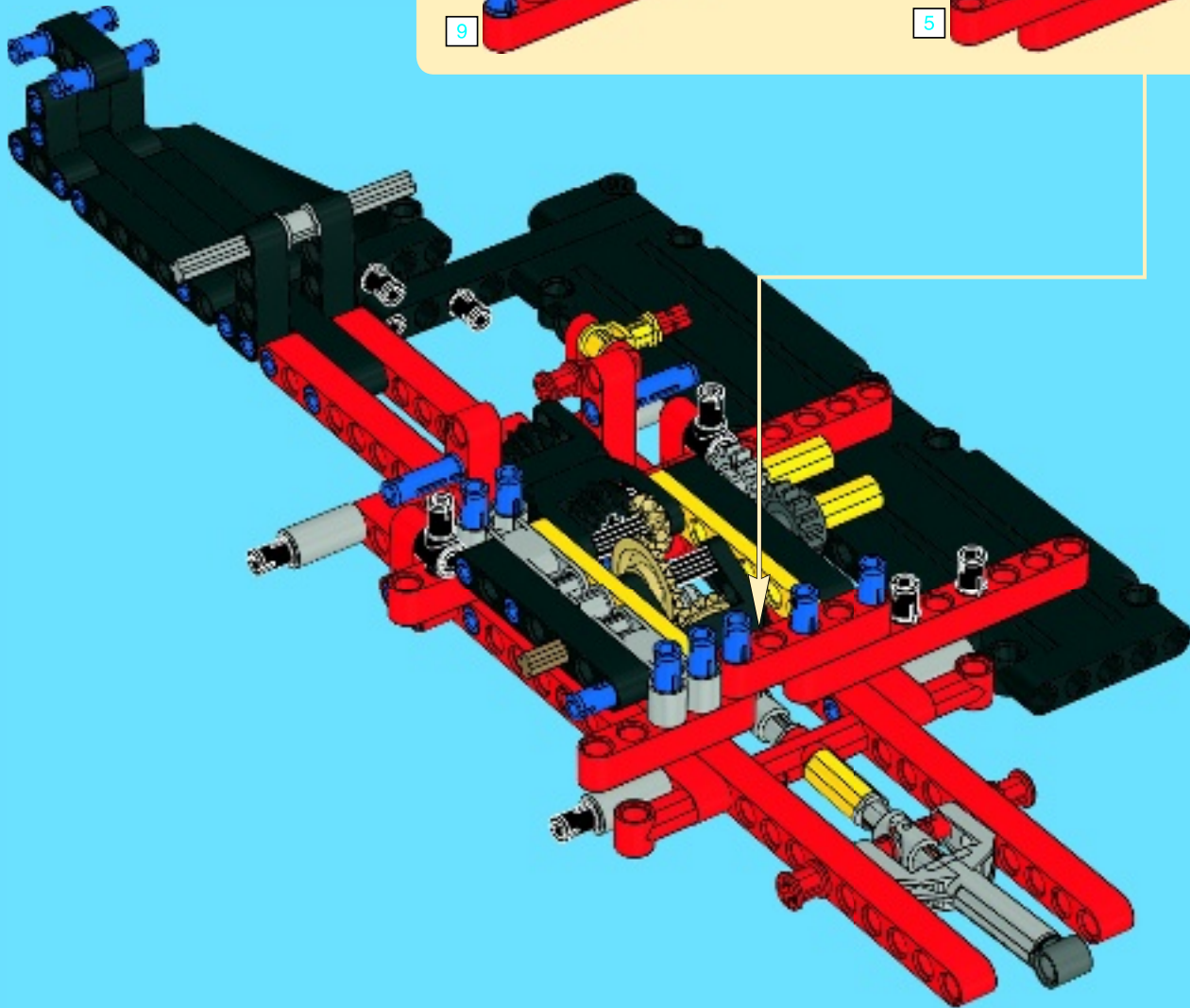
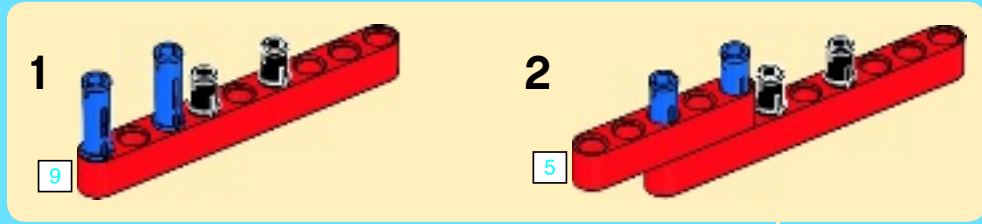



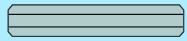
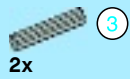

1:1

18

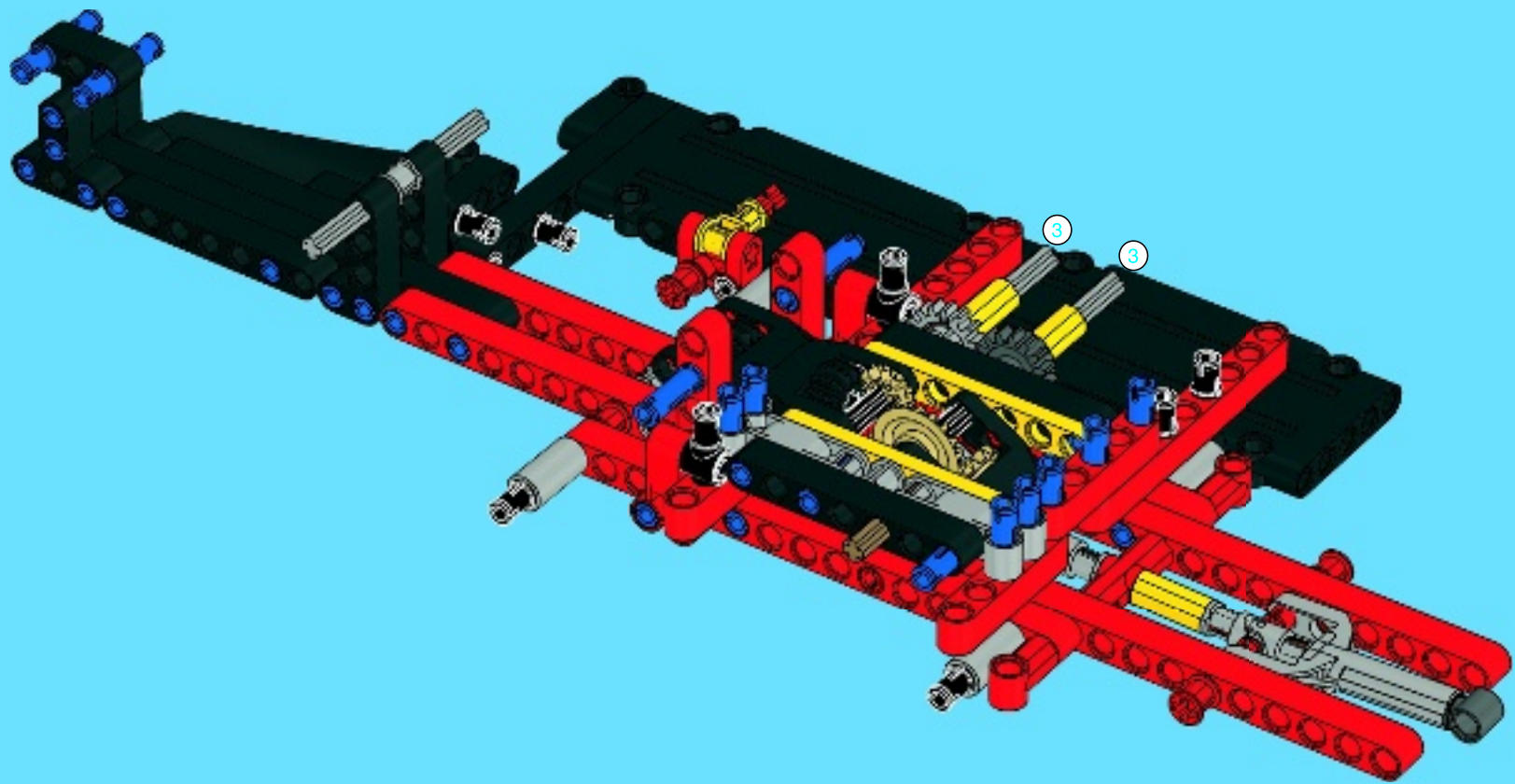



1x



1x

# 19

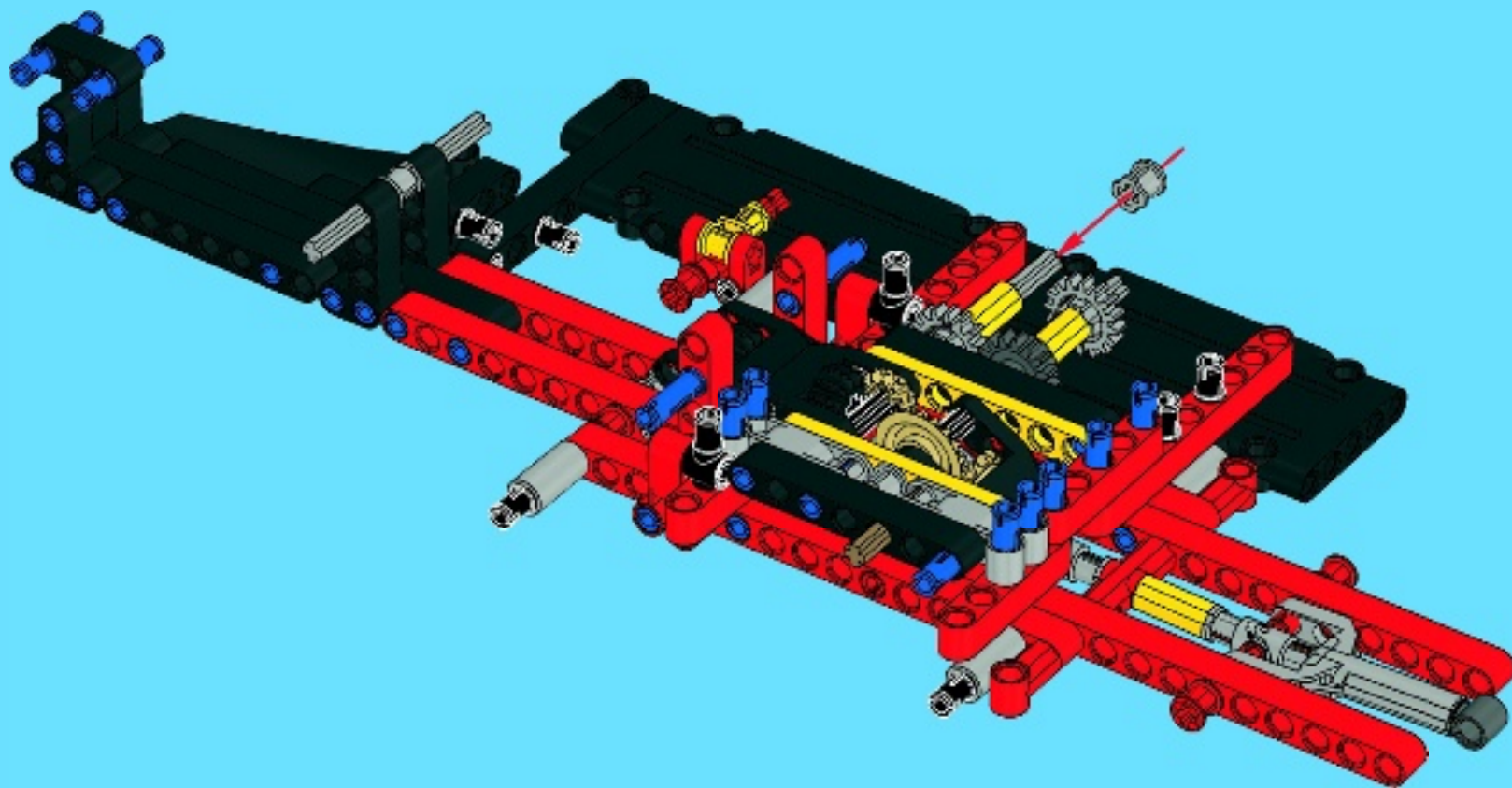

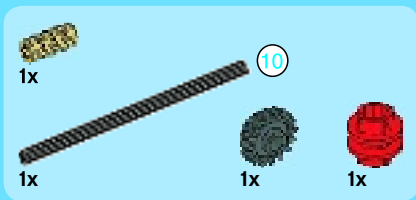

20

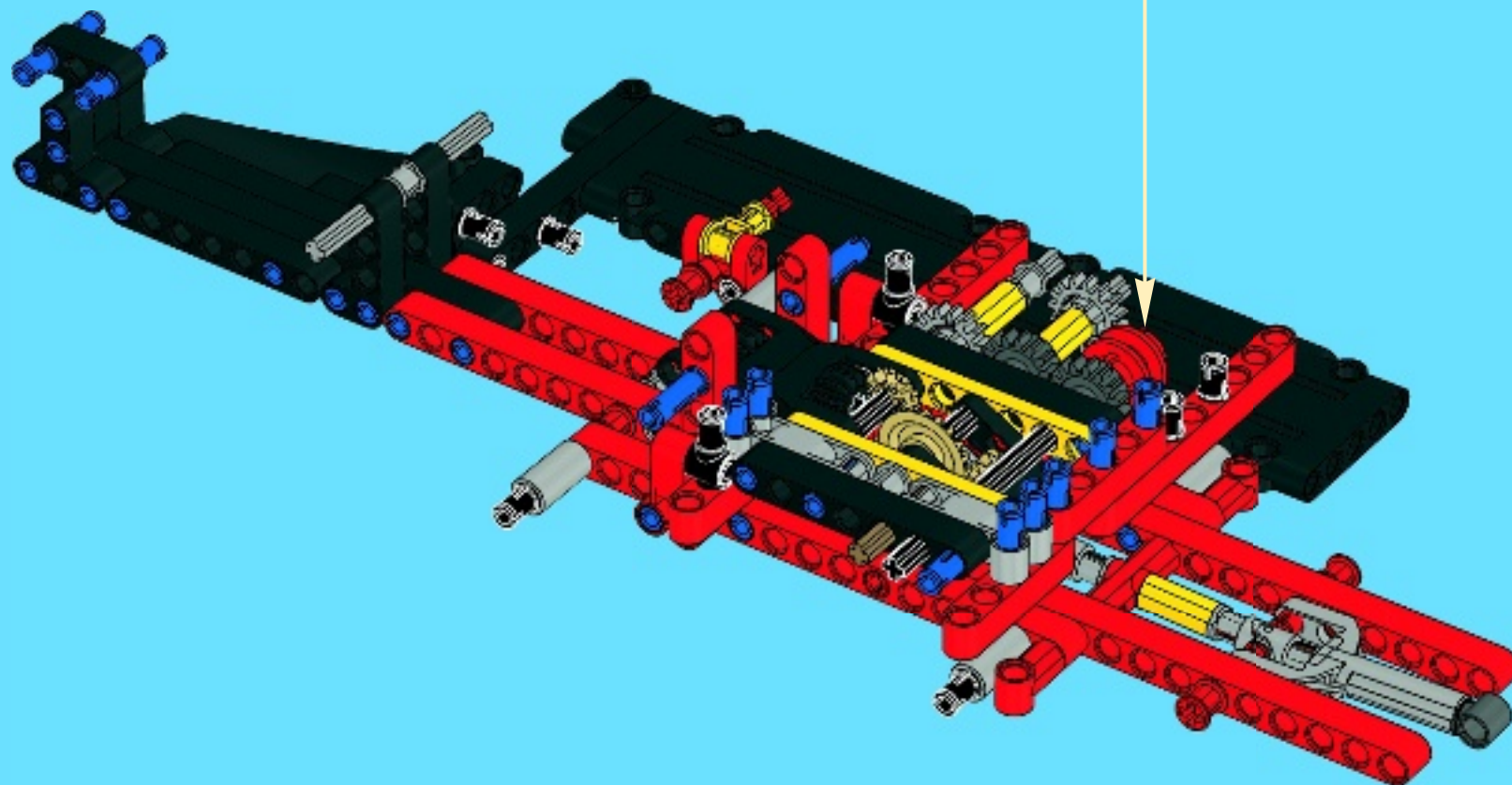
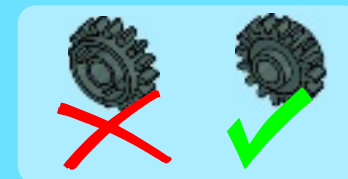
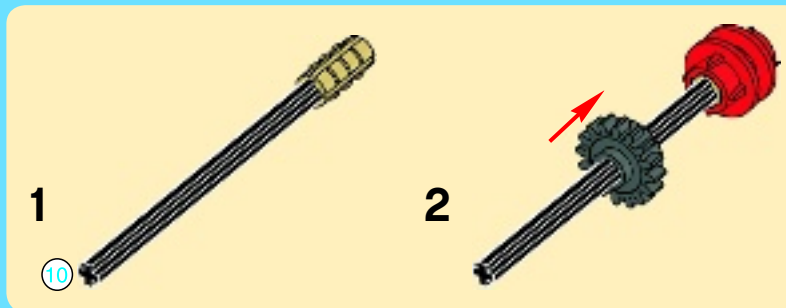

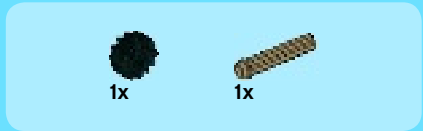

1

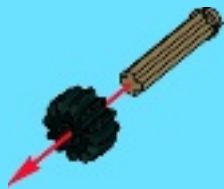

2



3



4

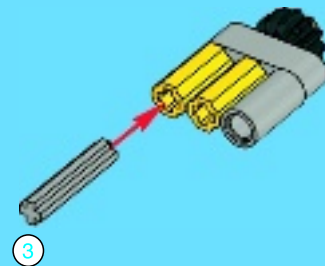
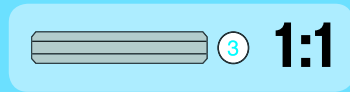

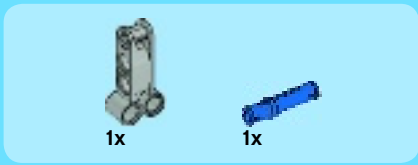

5

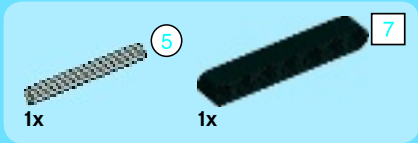

6

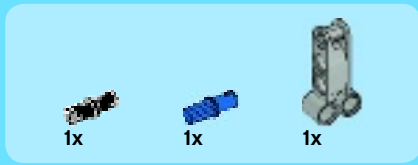
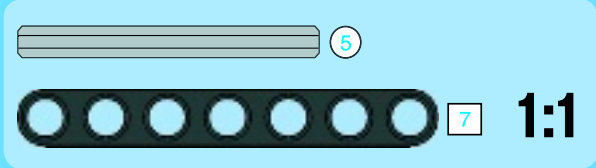
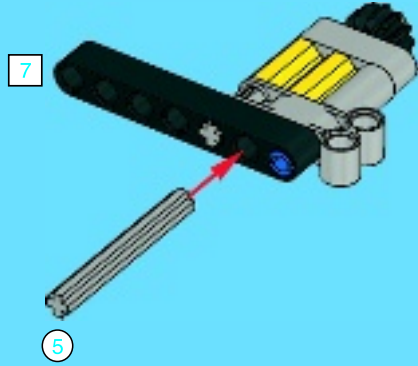

7

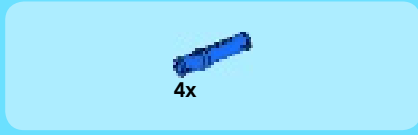
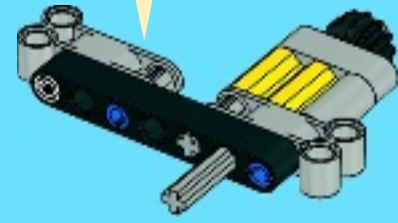
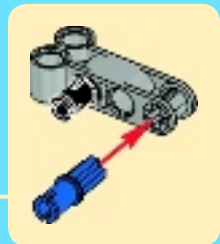

8

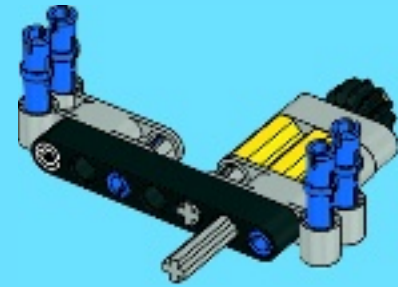



1x

9

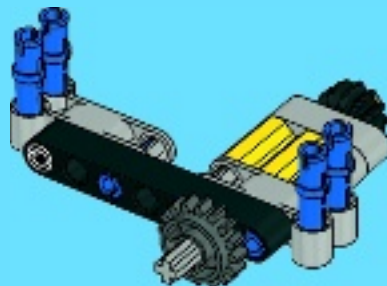
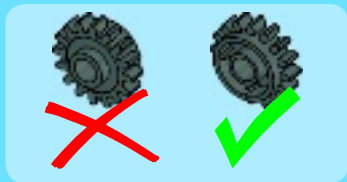

21

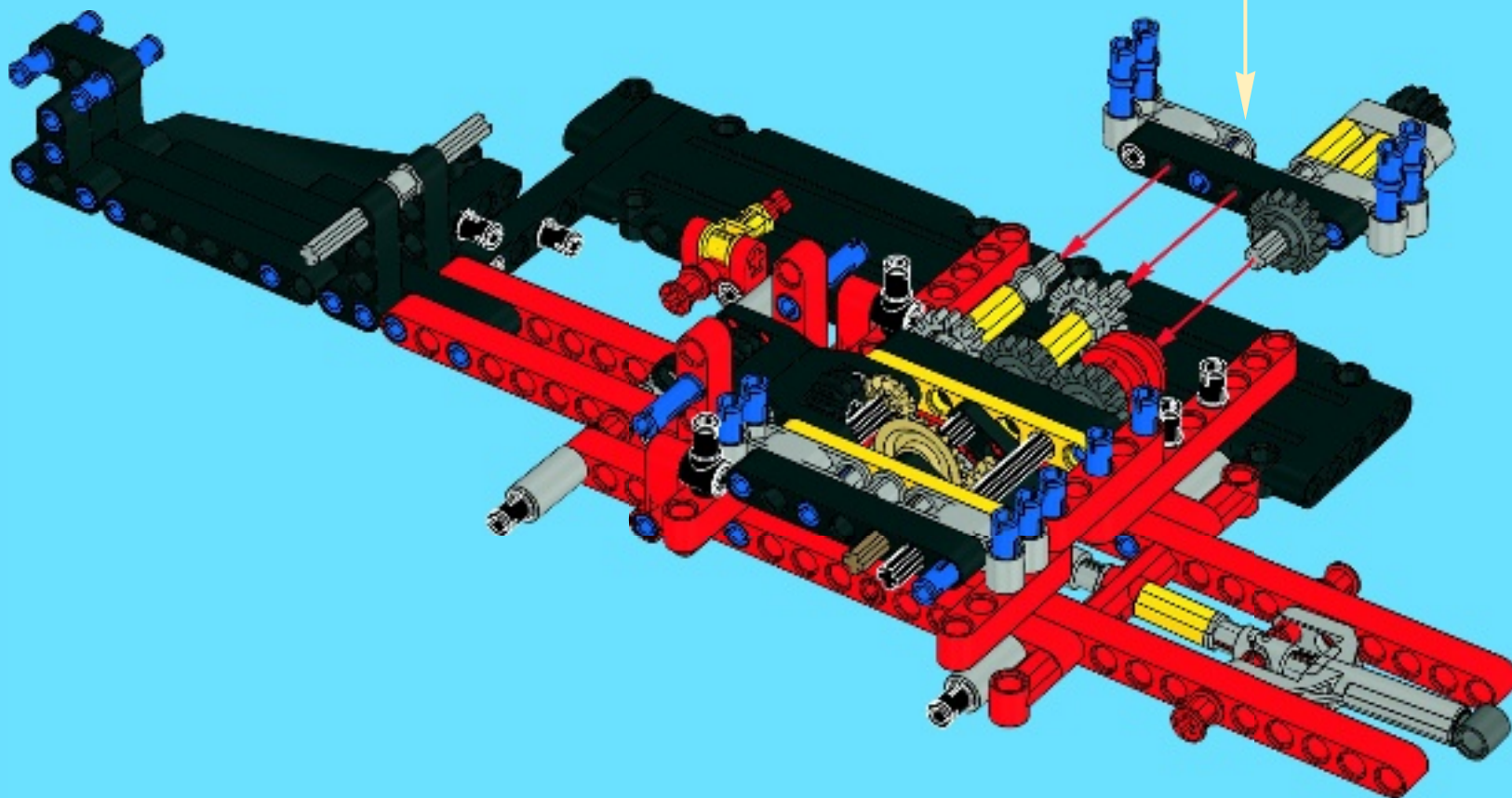

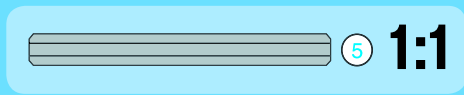
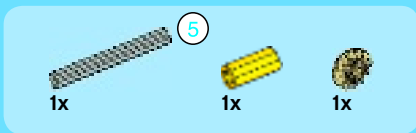

22

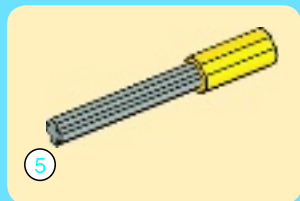
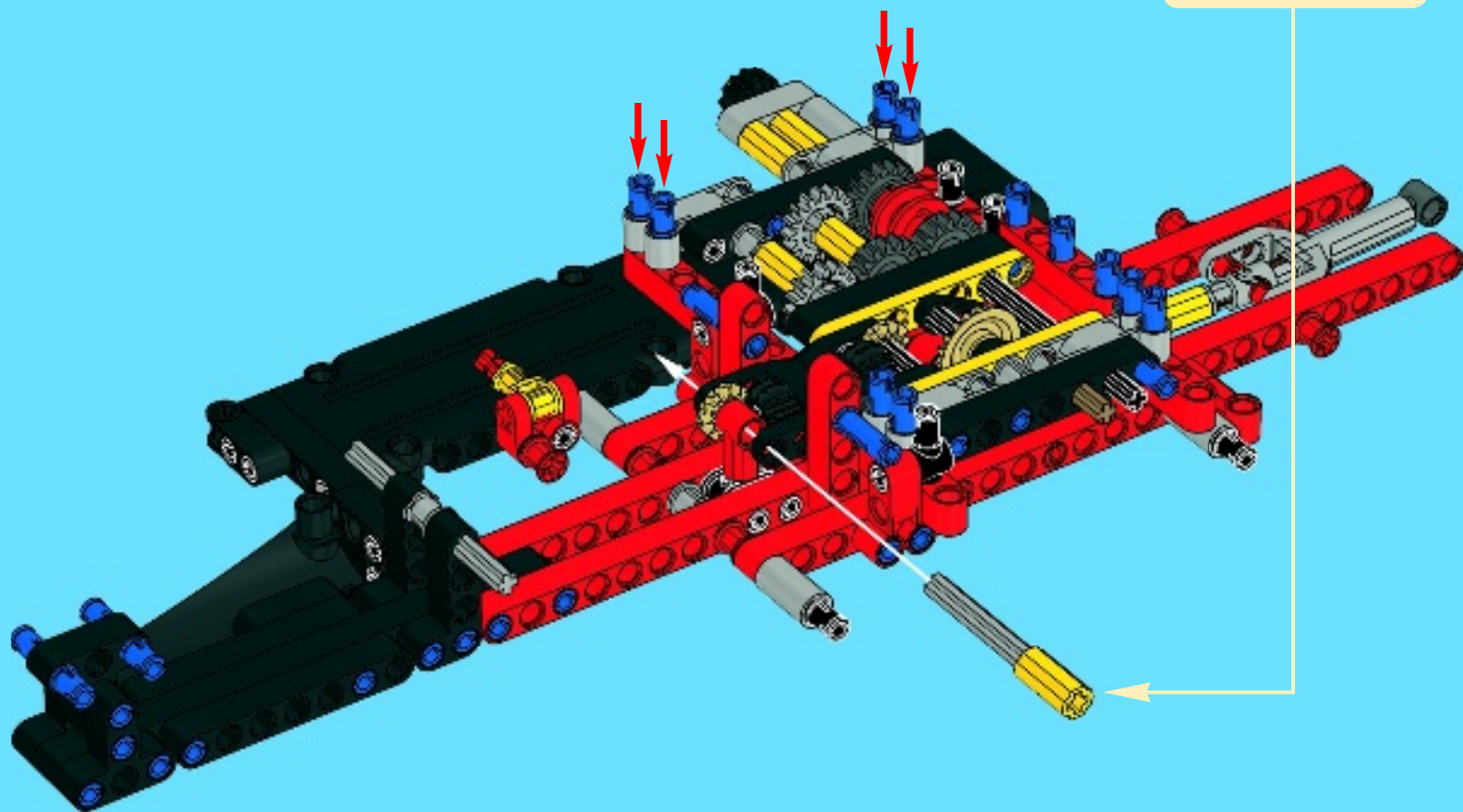

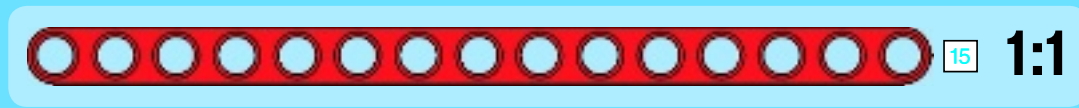
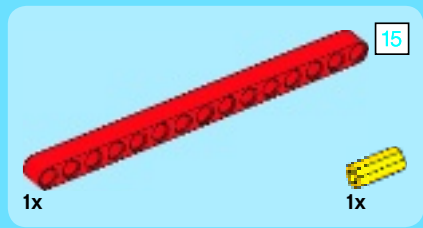

23

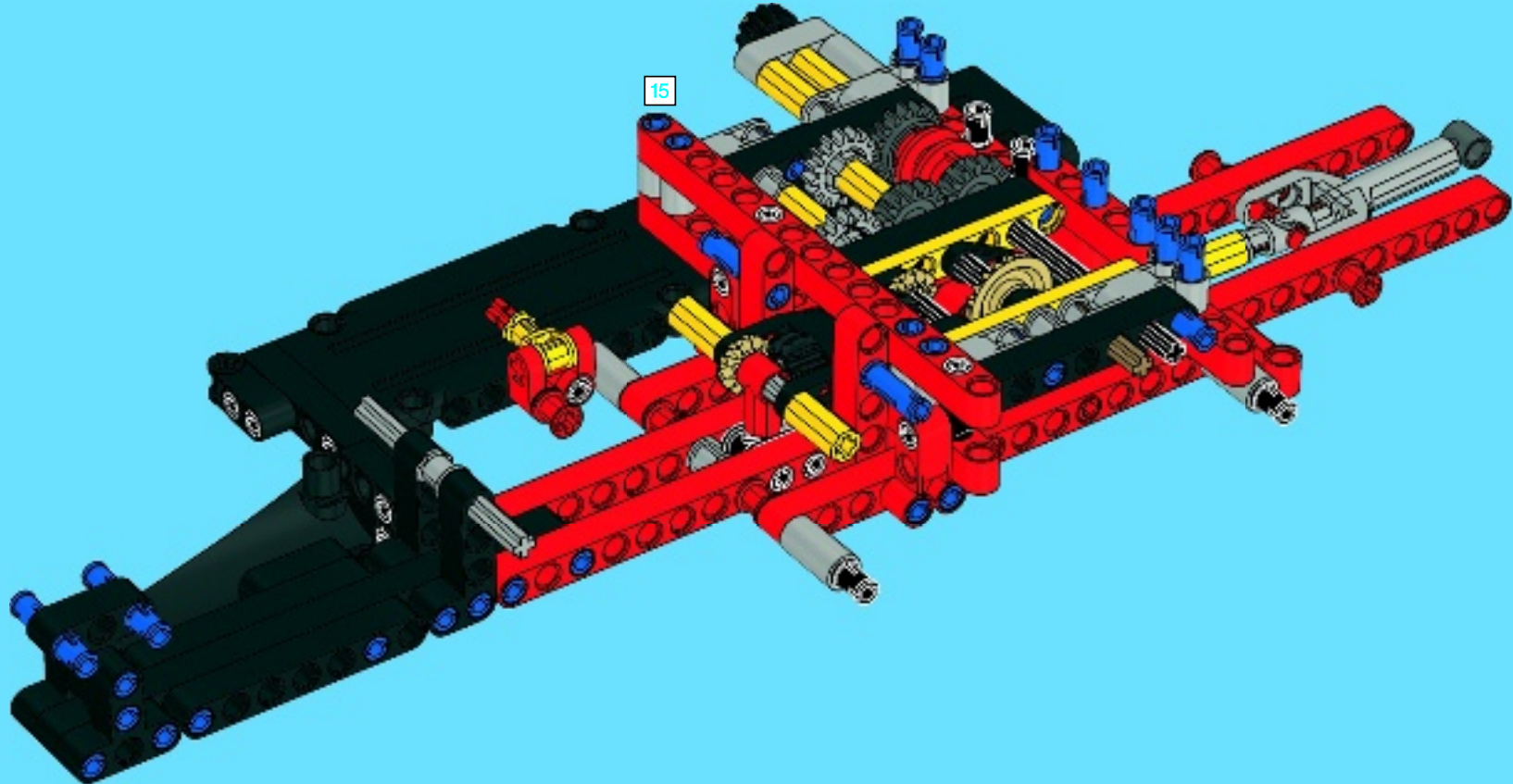



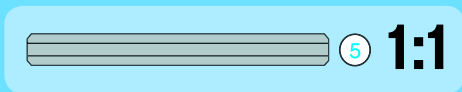
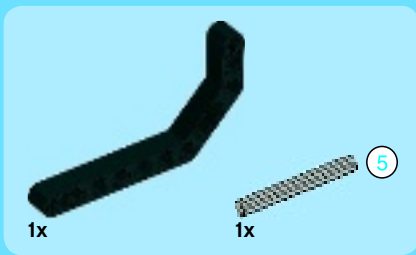

24

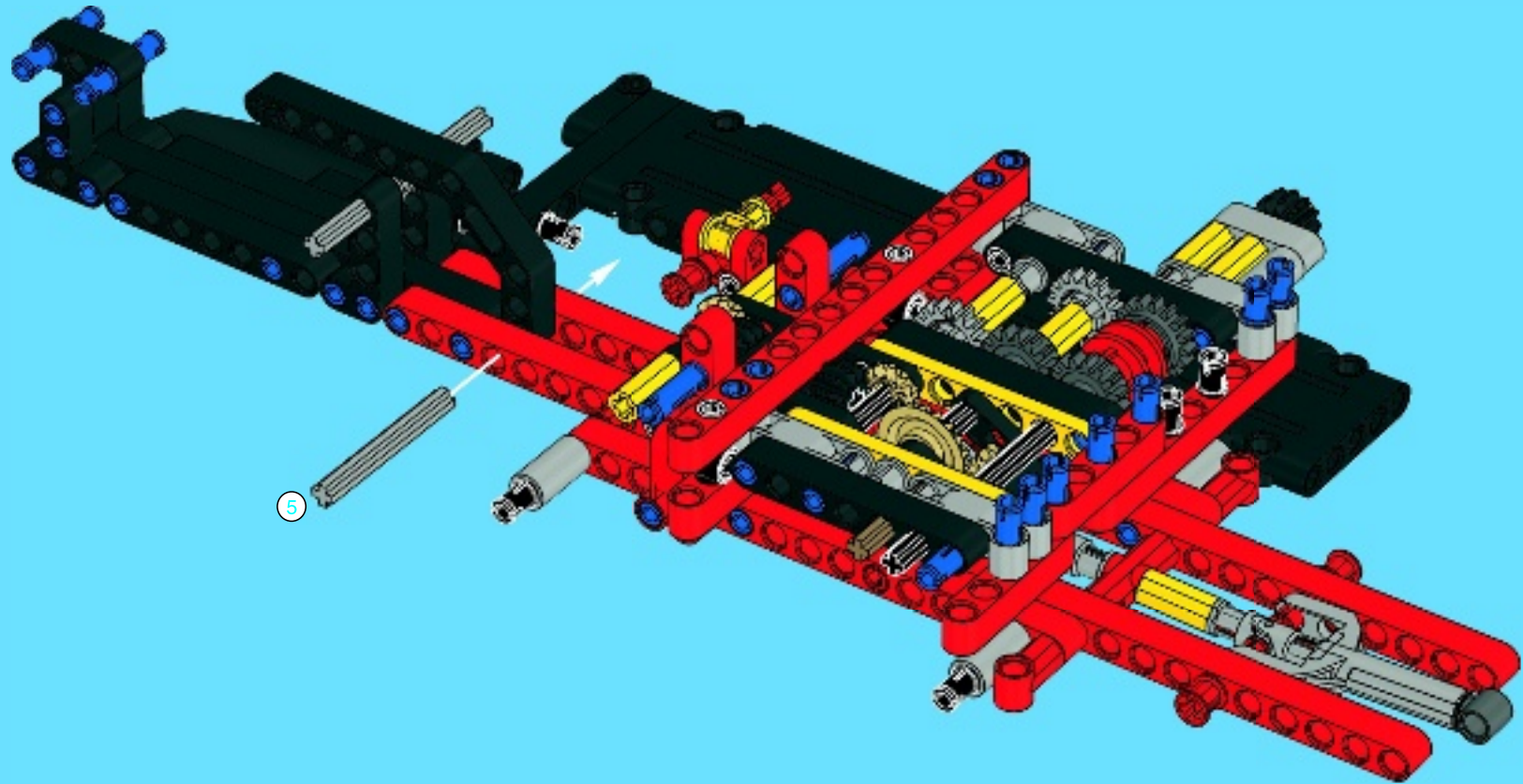

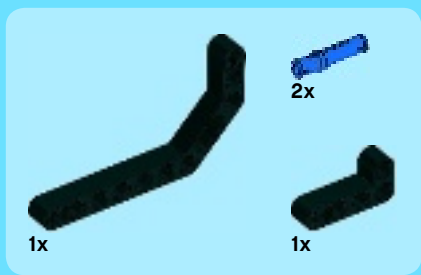

25

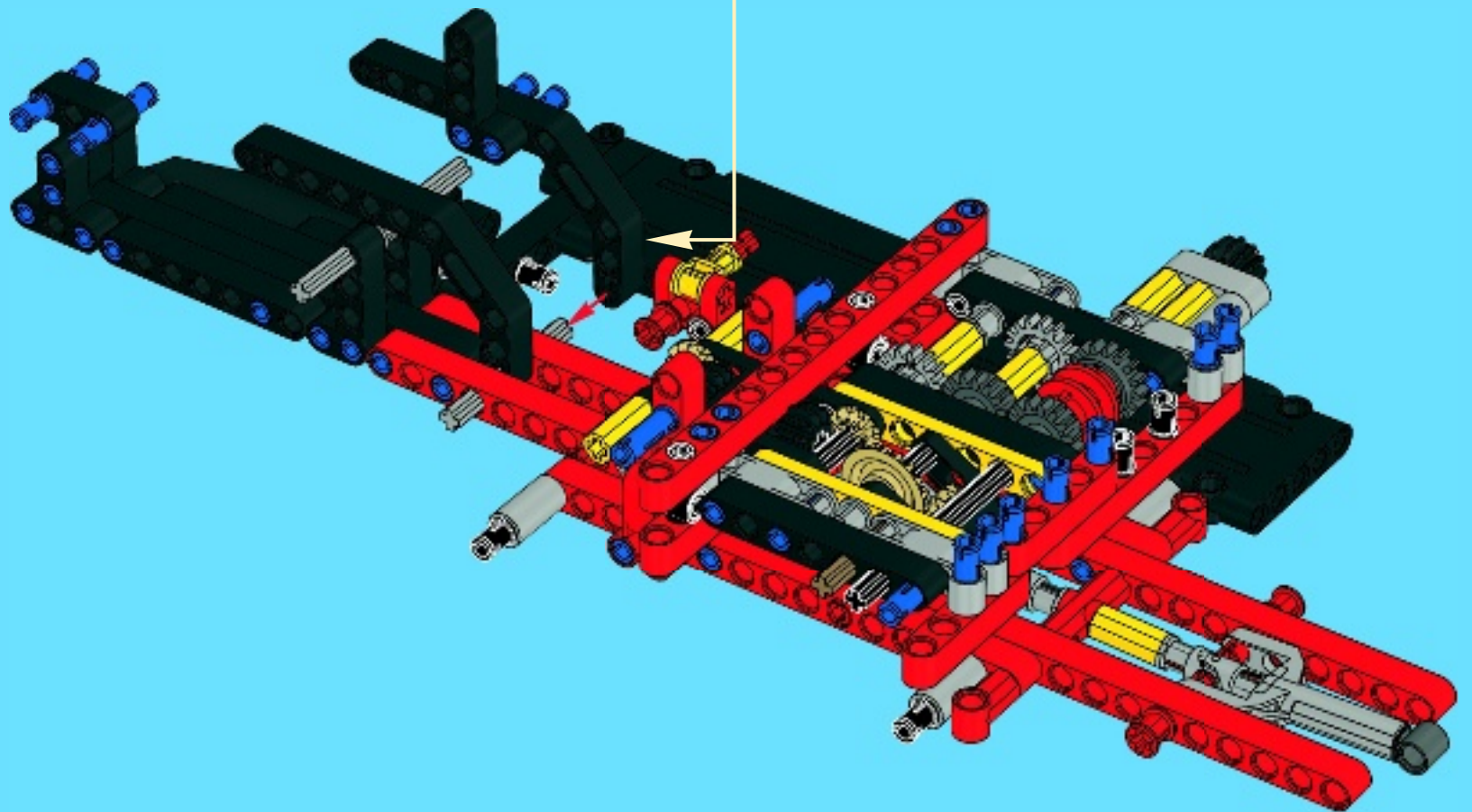
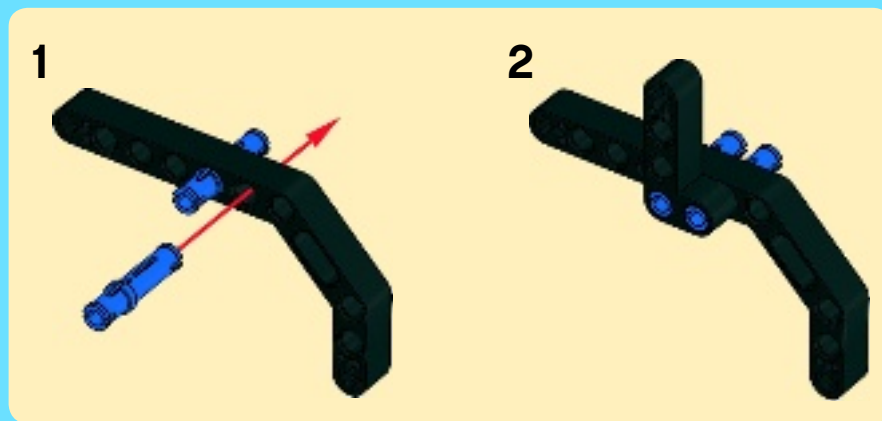

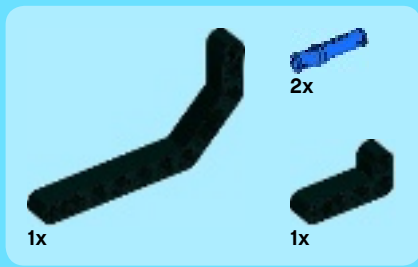

26

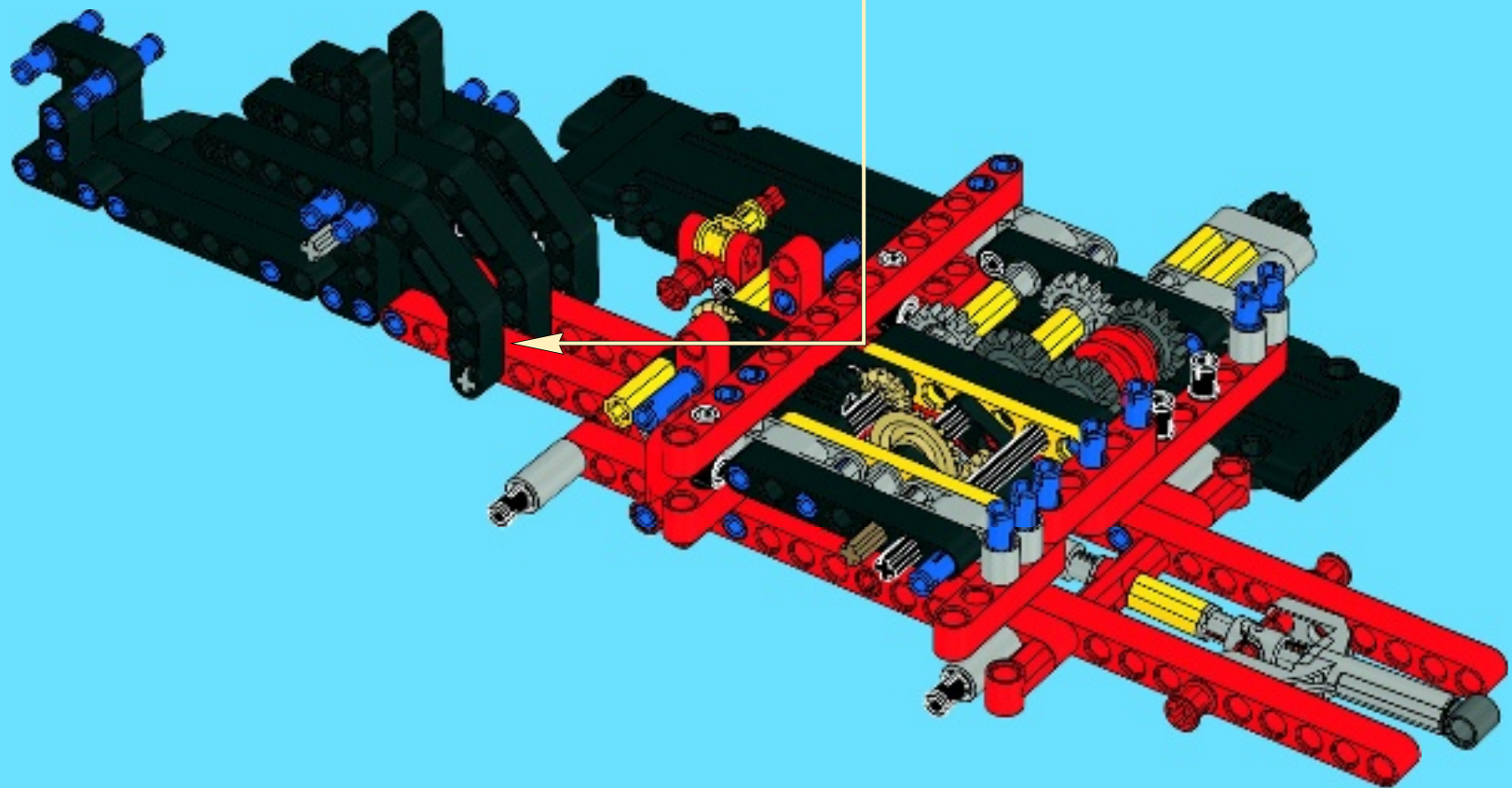
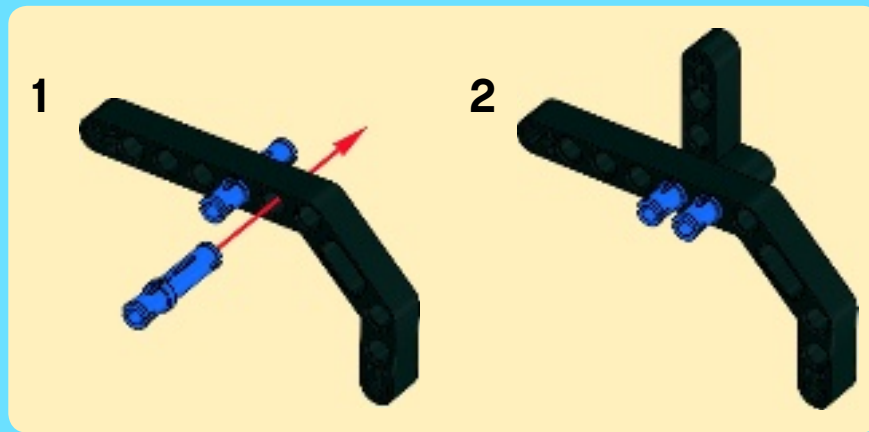

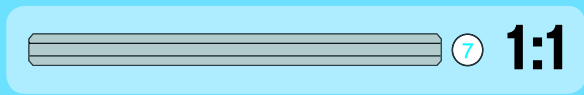
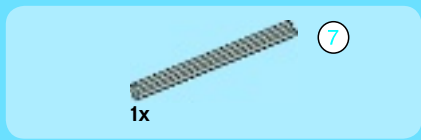

27

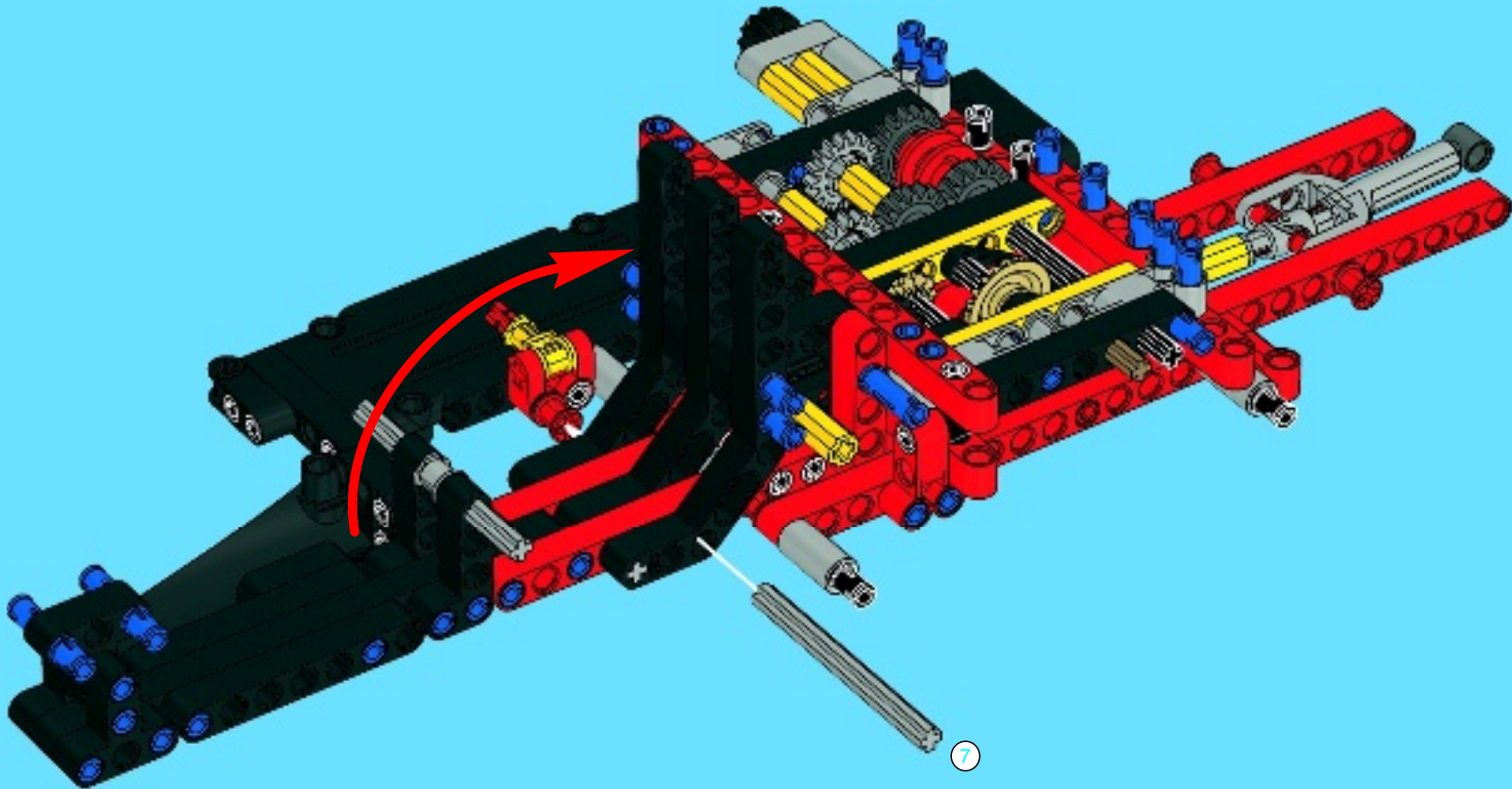

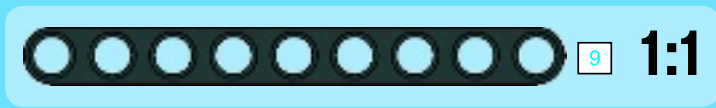
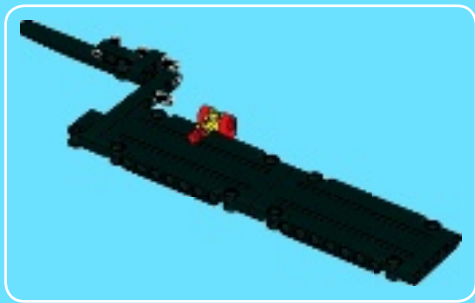

1



2

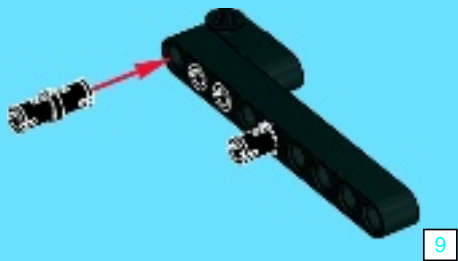

3

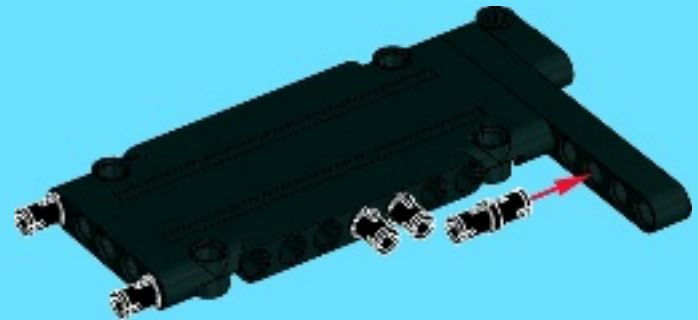



1x



2x



1x

# 4

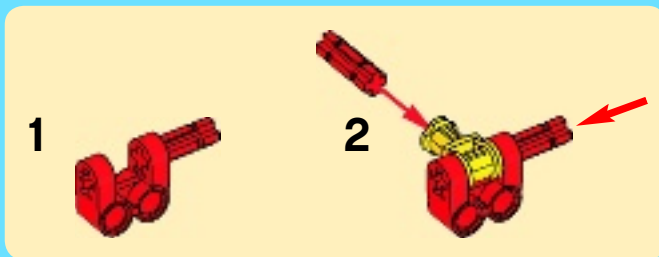
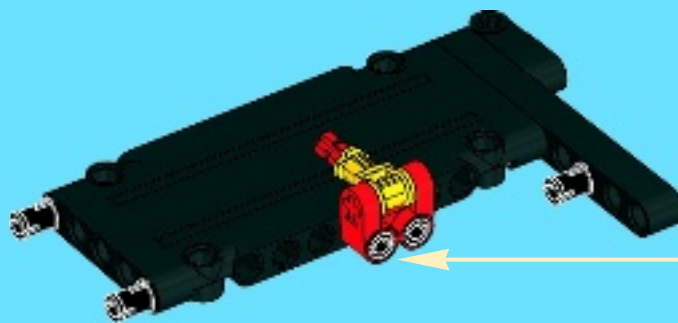

# 5

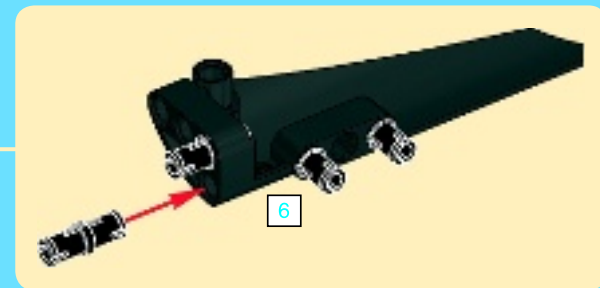
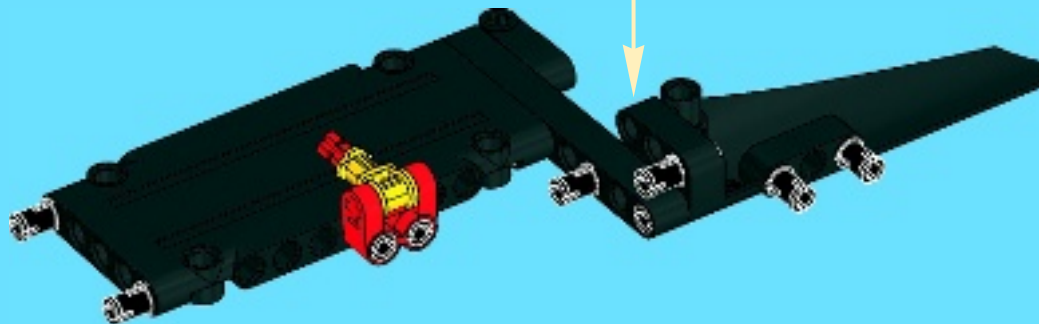



6

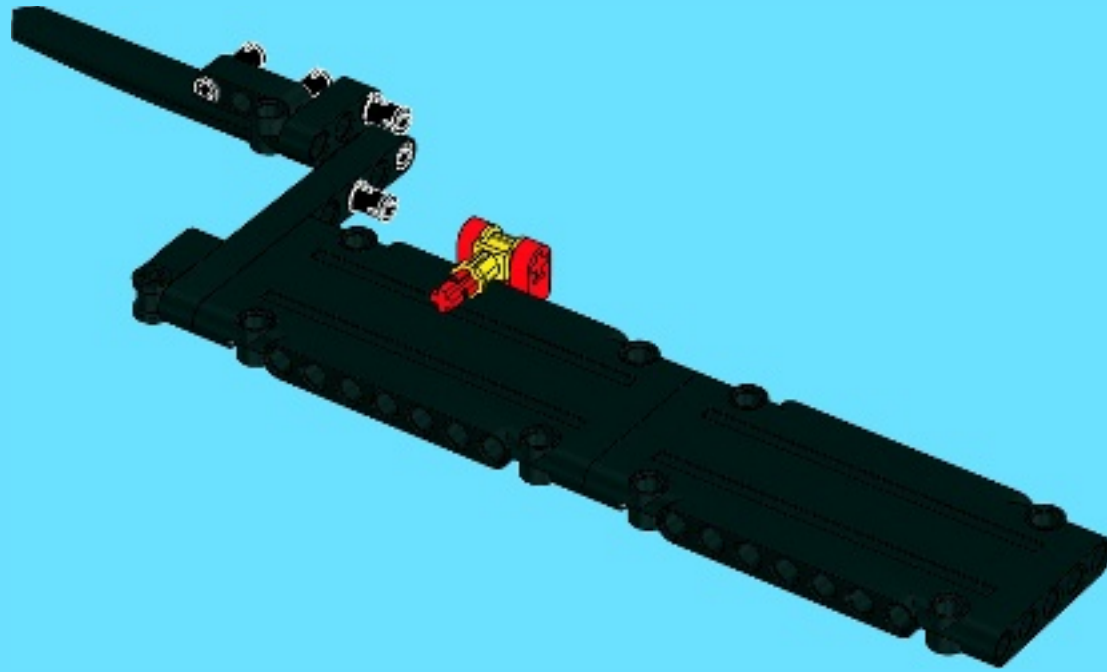

28

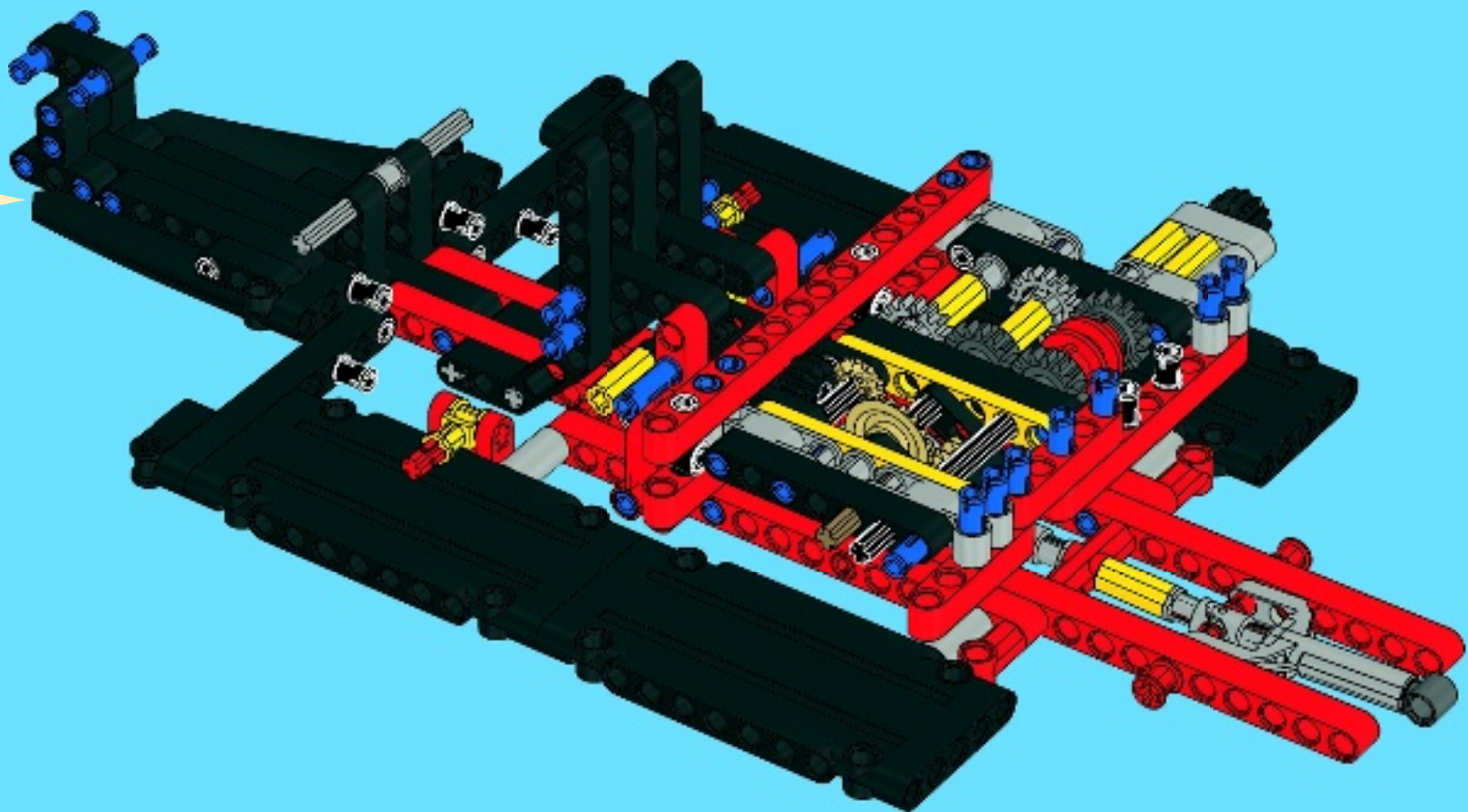





29

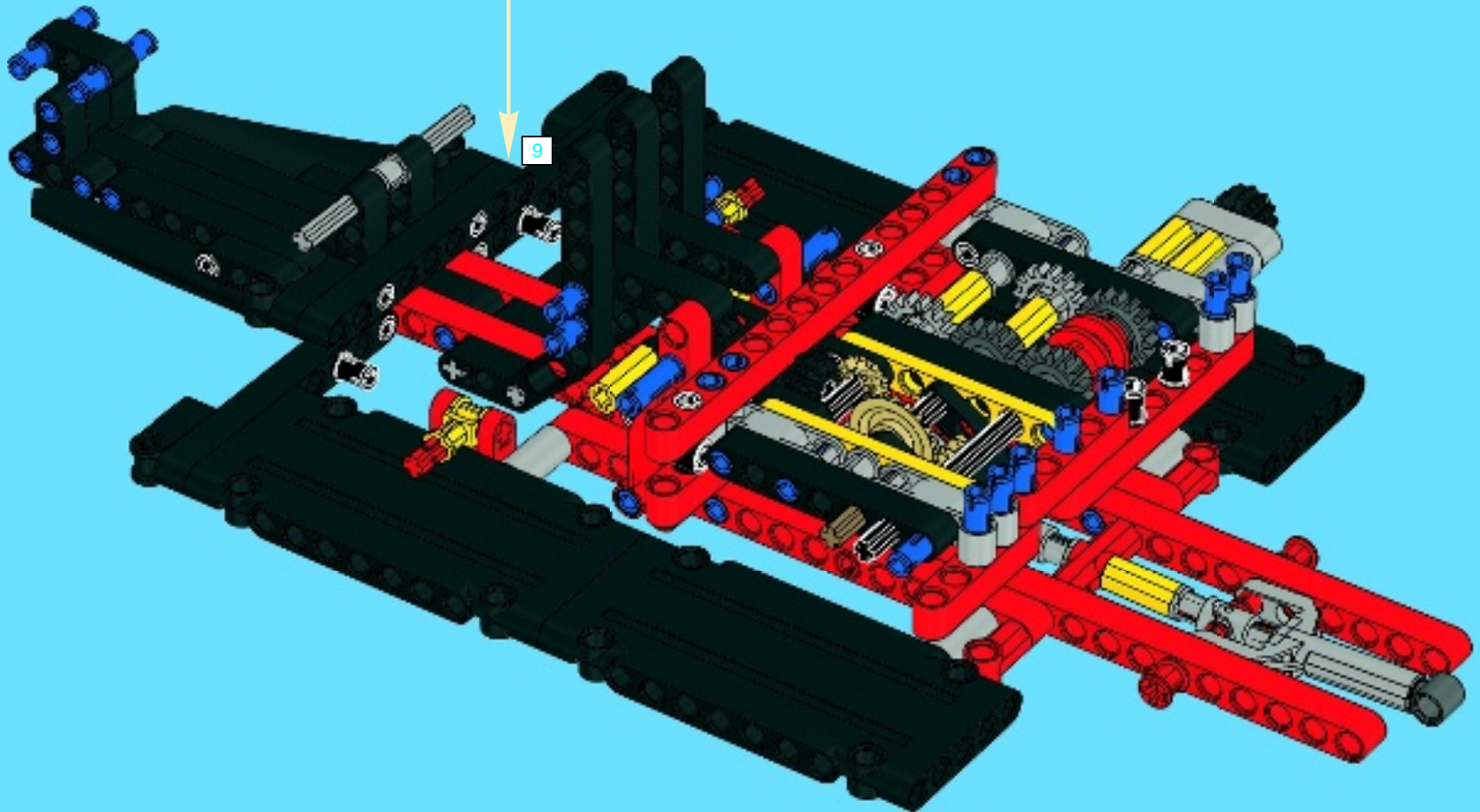



2x



2x

# 30

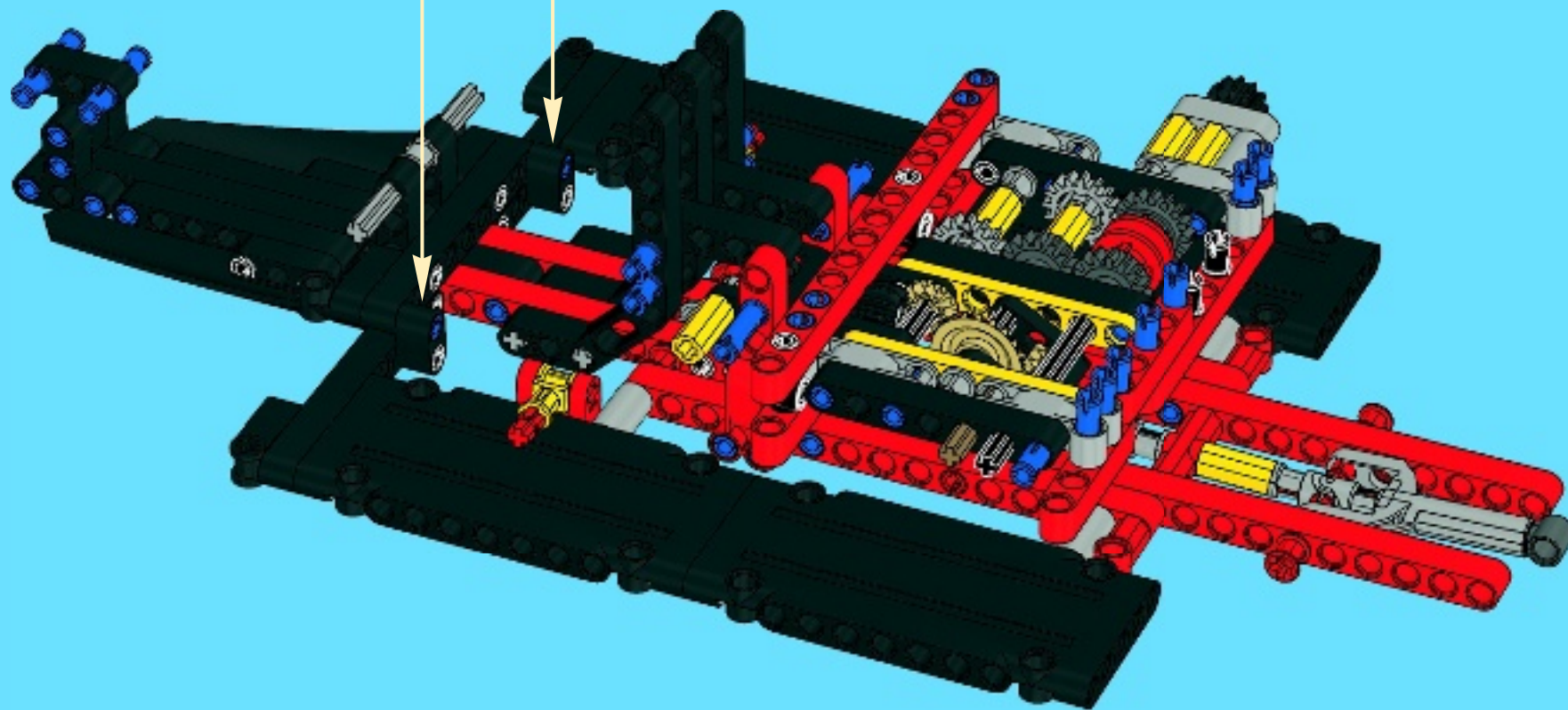
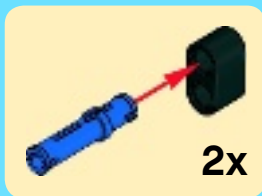

5x

1x

# 31

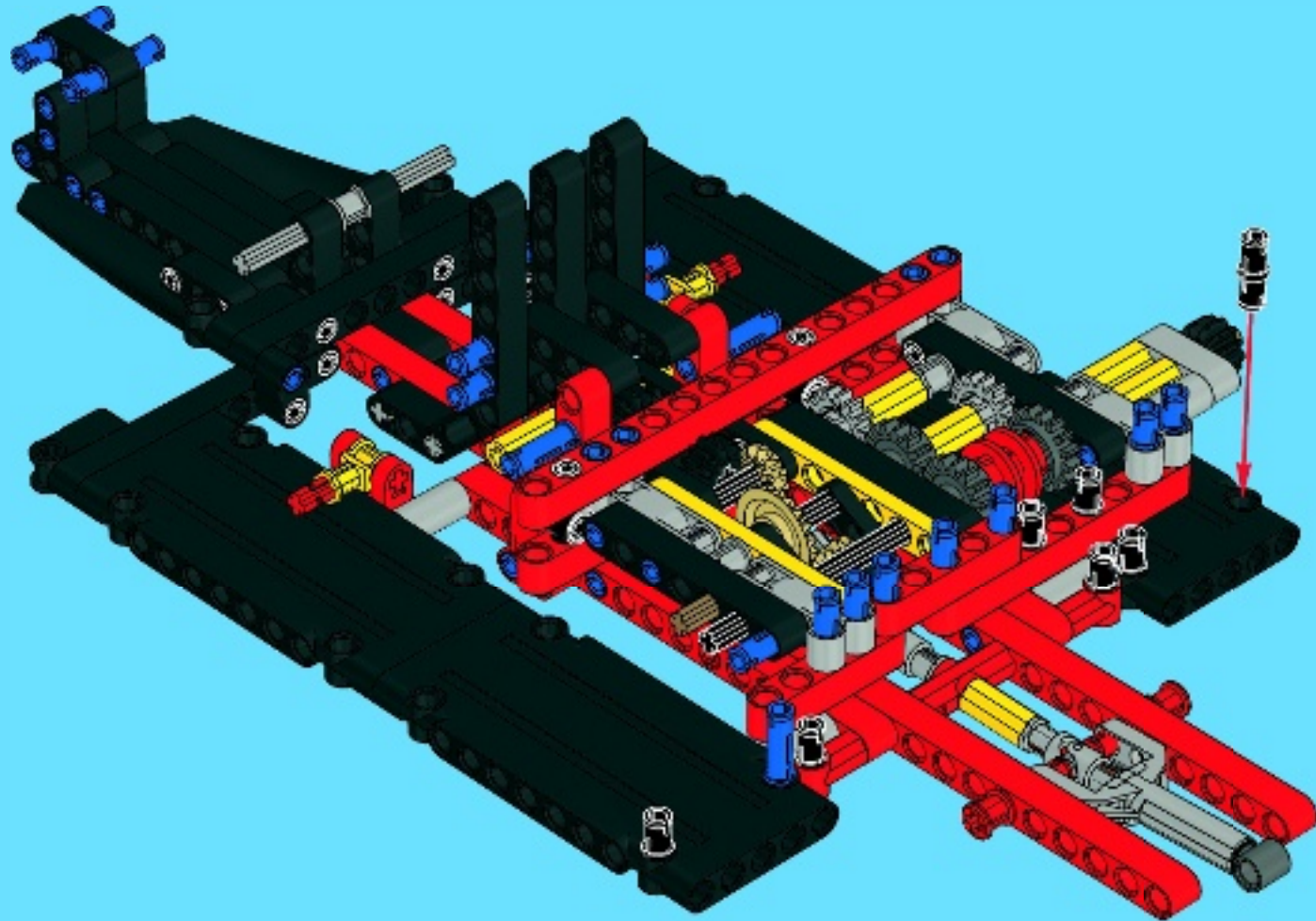

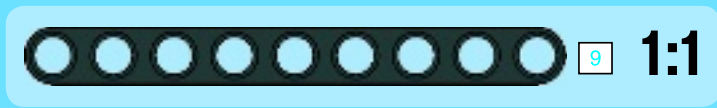

32

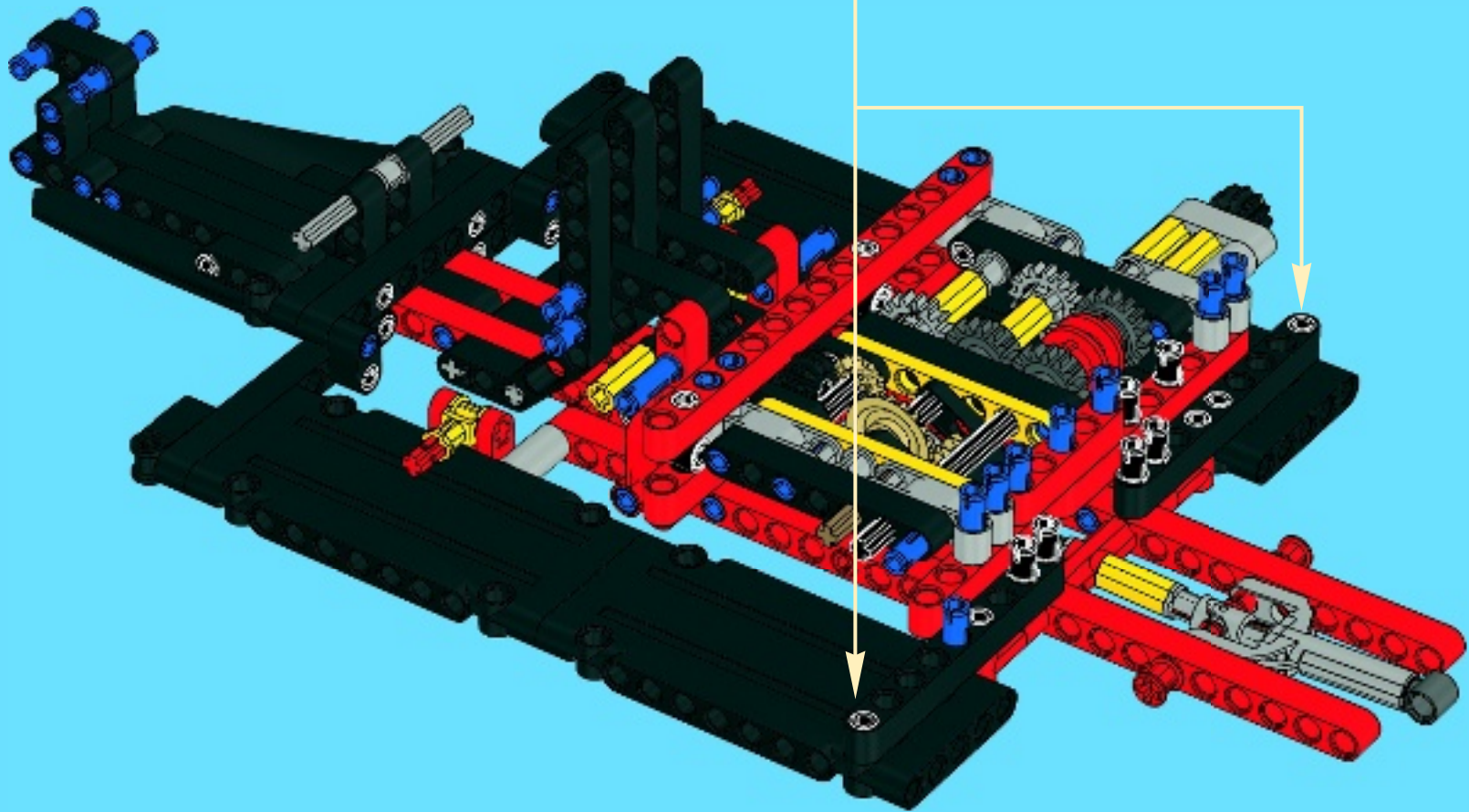

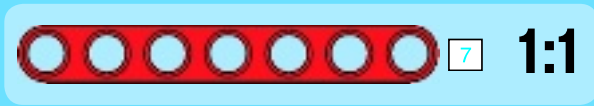
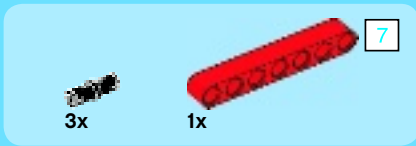

33

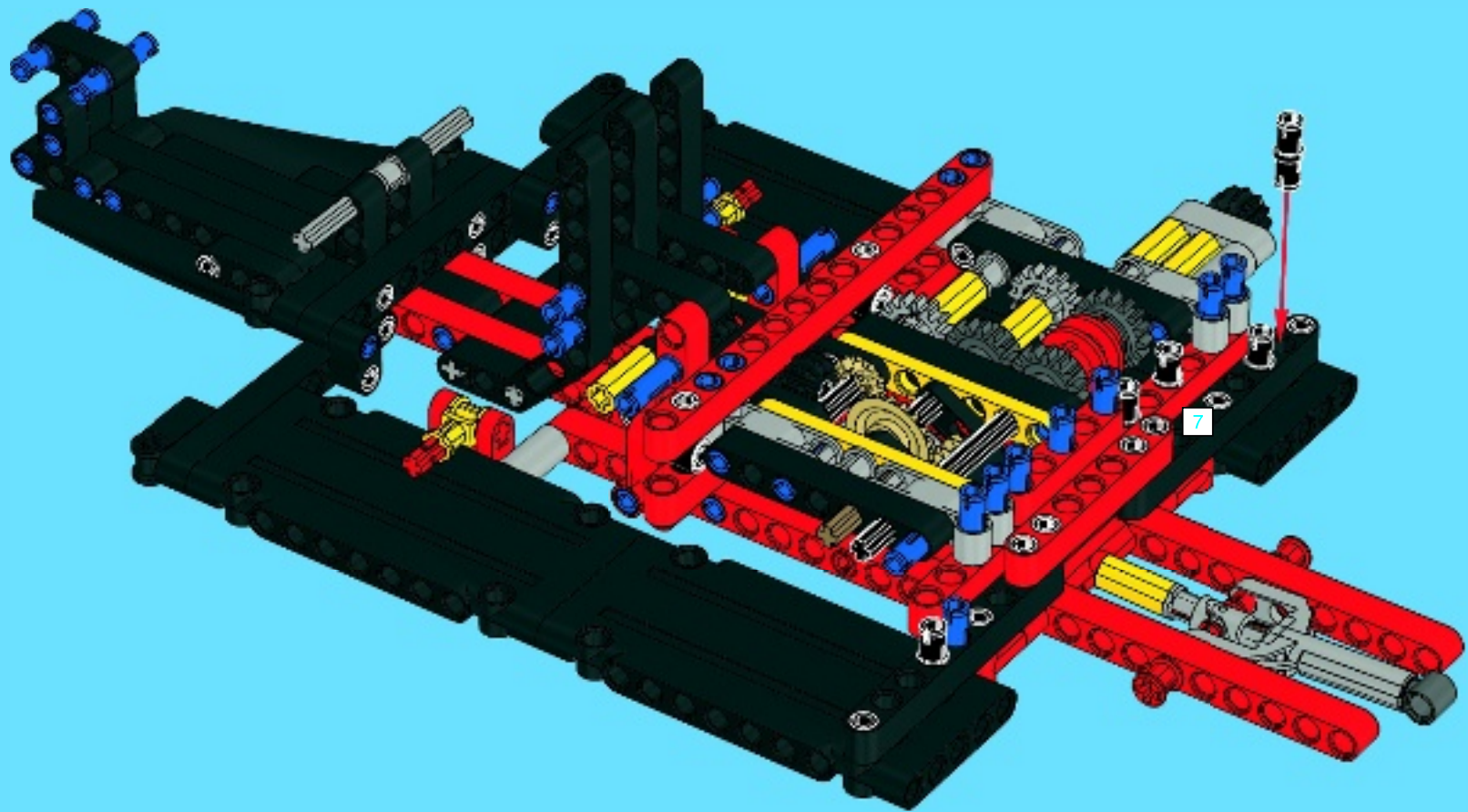



# 34

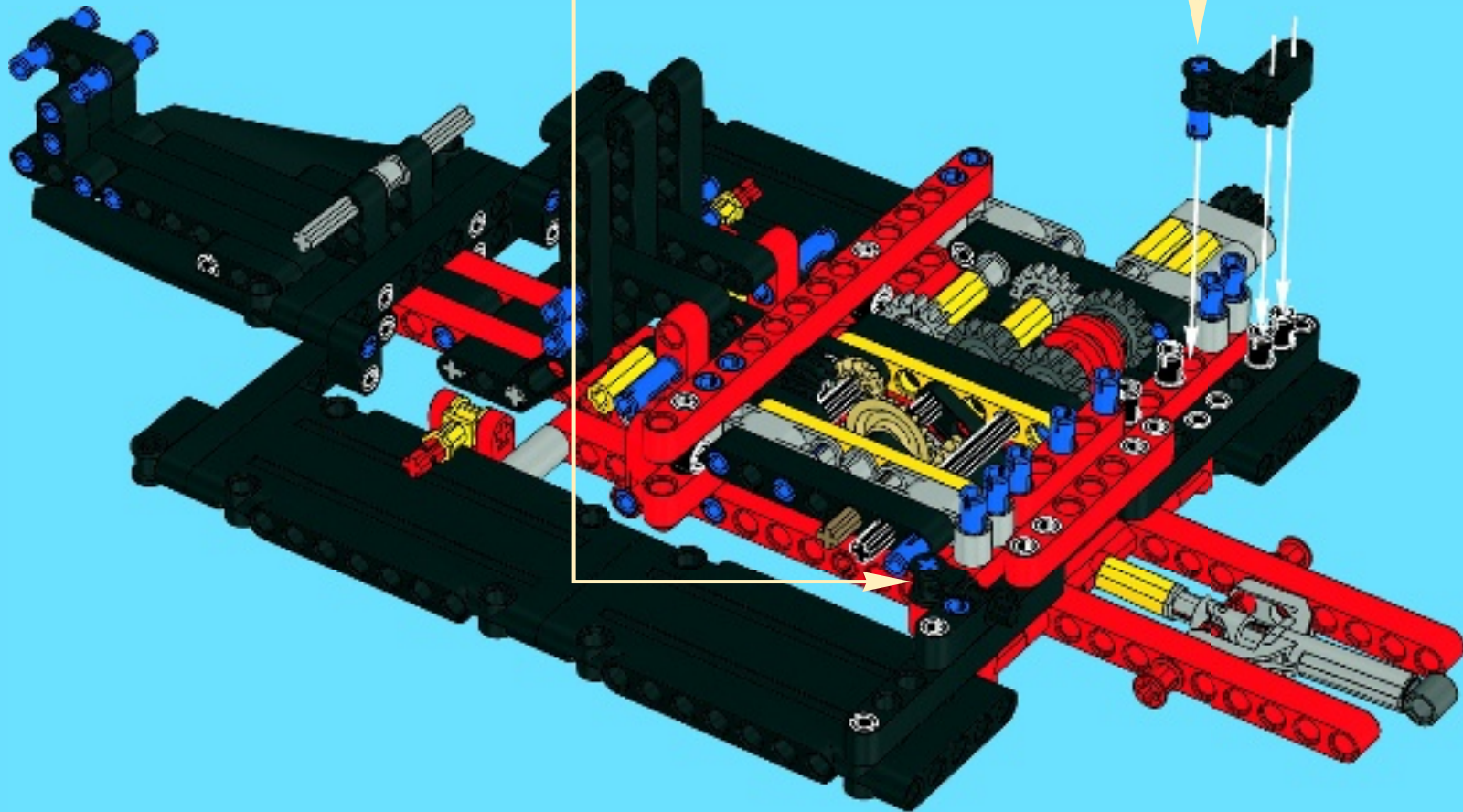

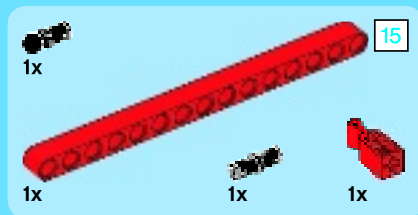

35

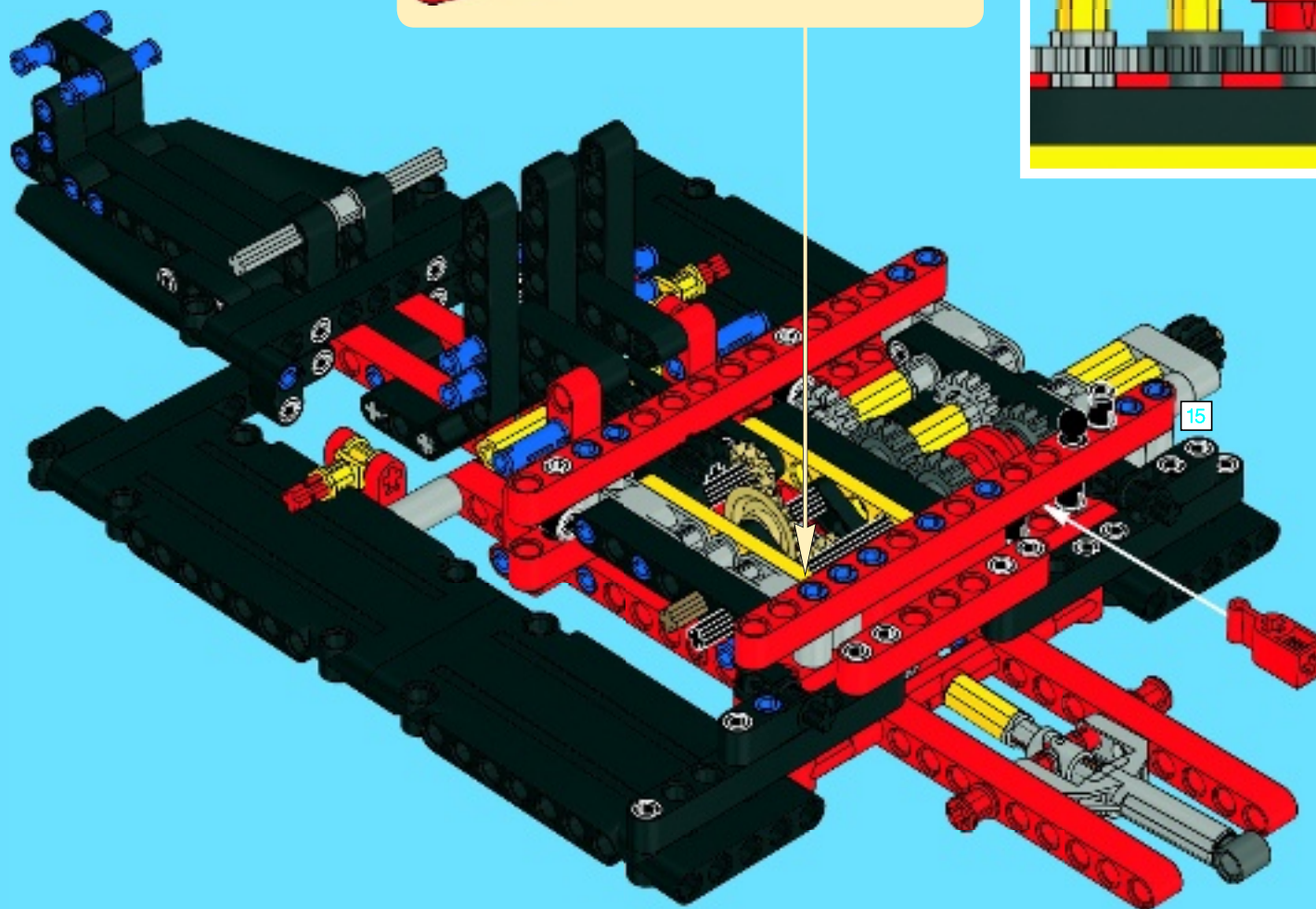
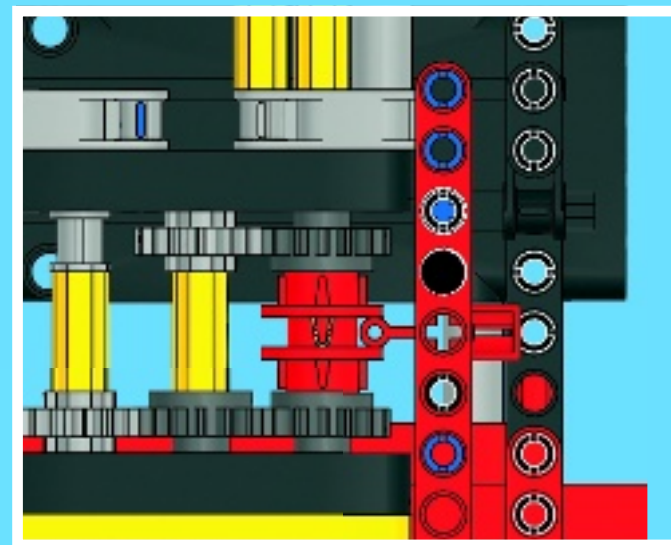
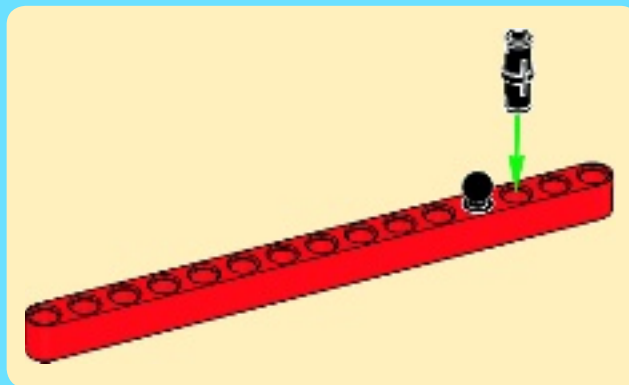

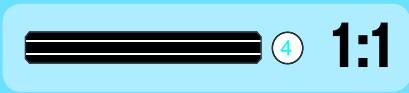
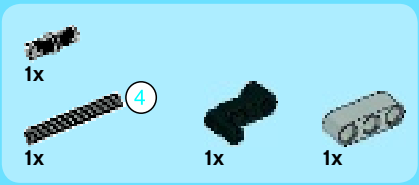

36

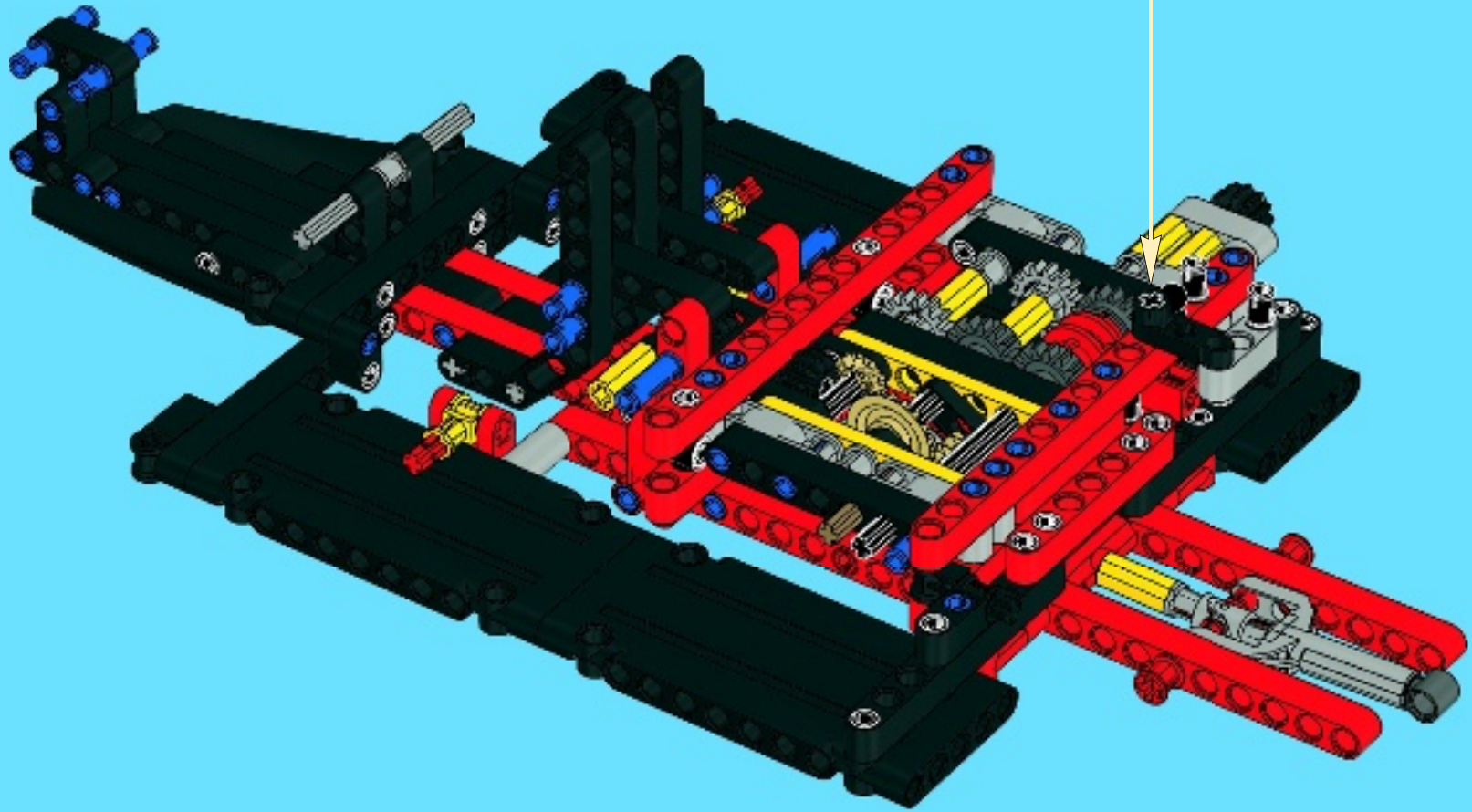



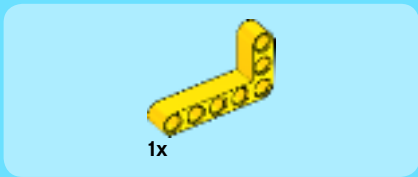

37

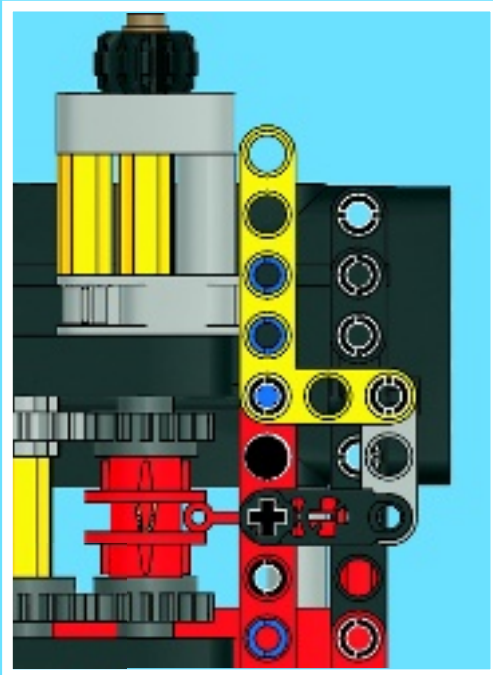
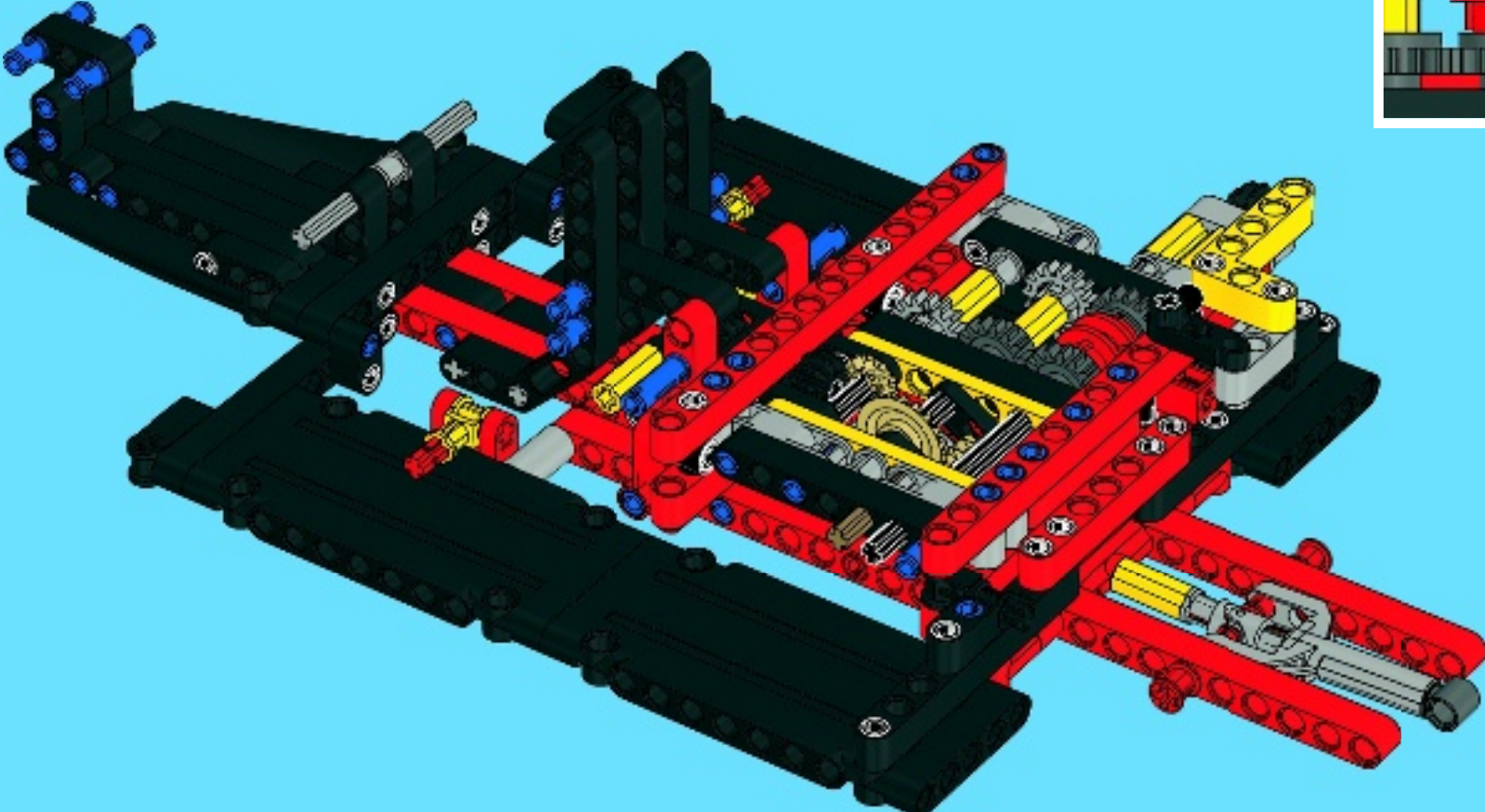

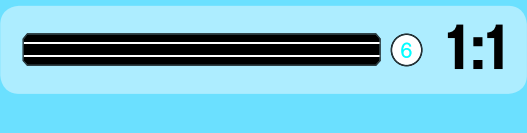
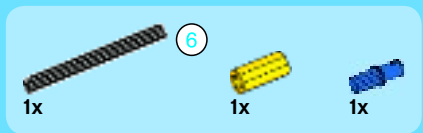

1

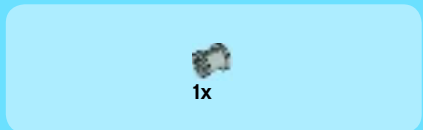
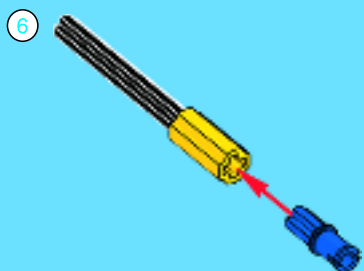

2

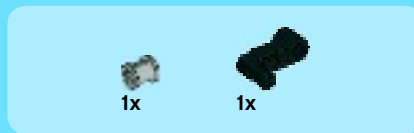
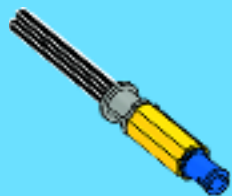



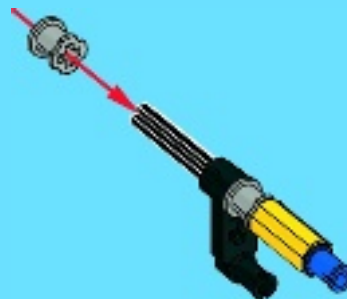

3

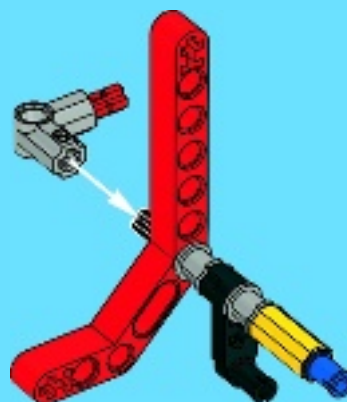
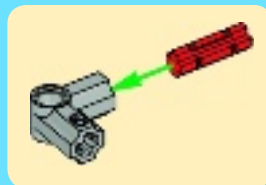

4



- 1x 
- 1x 
- 1x 
- 1x 

5

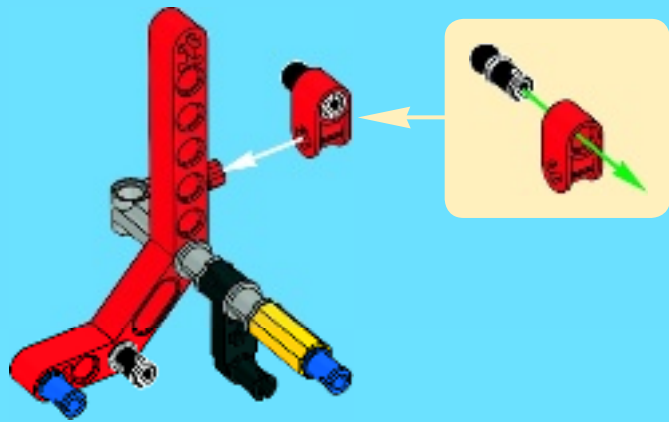

38

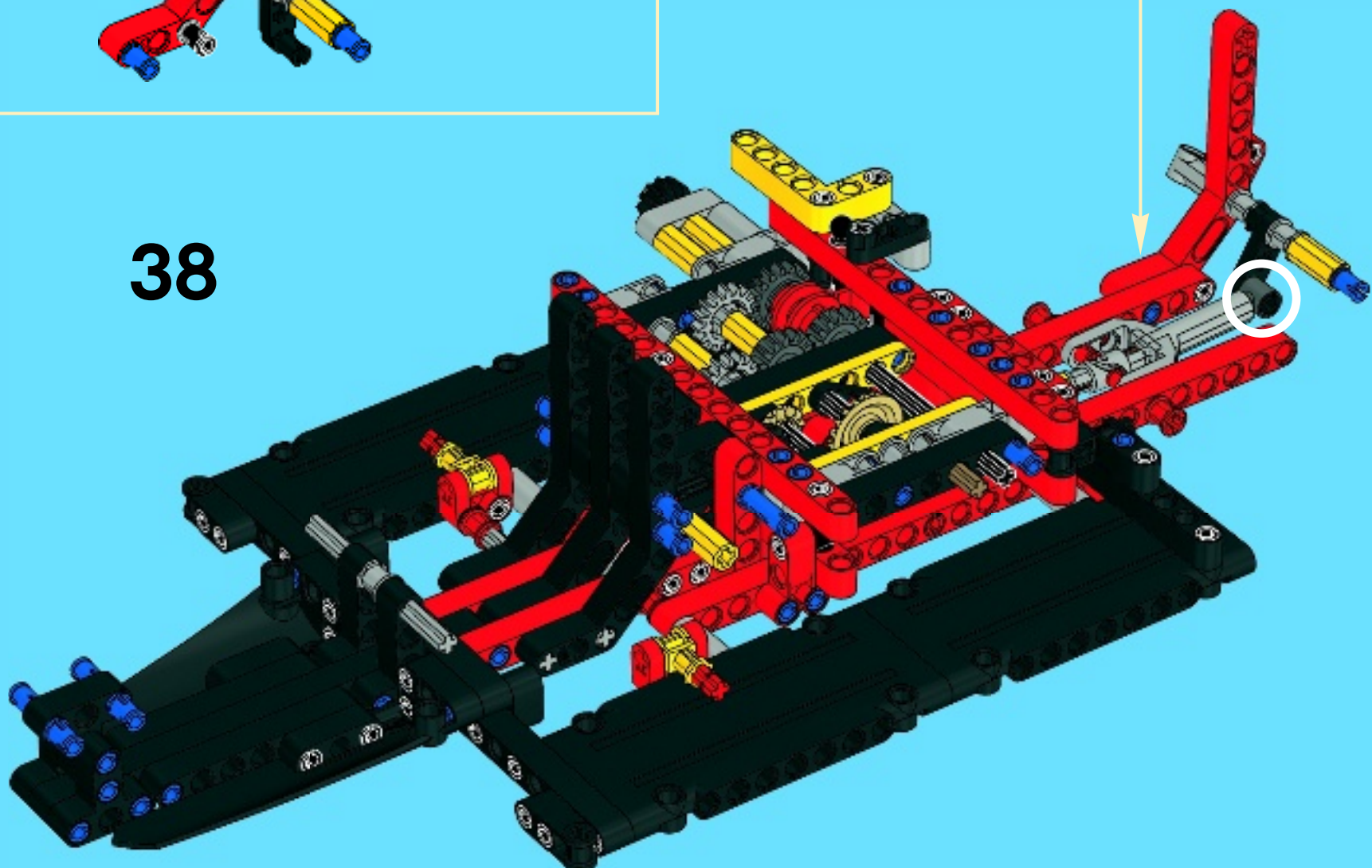



39

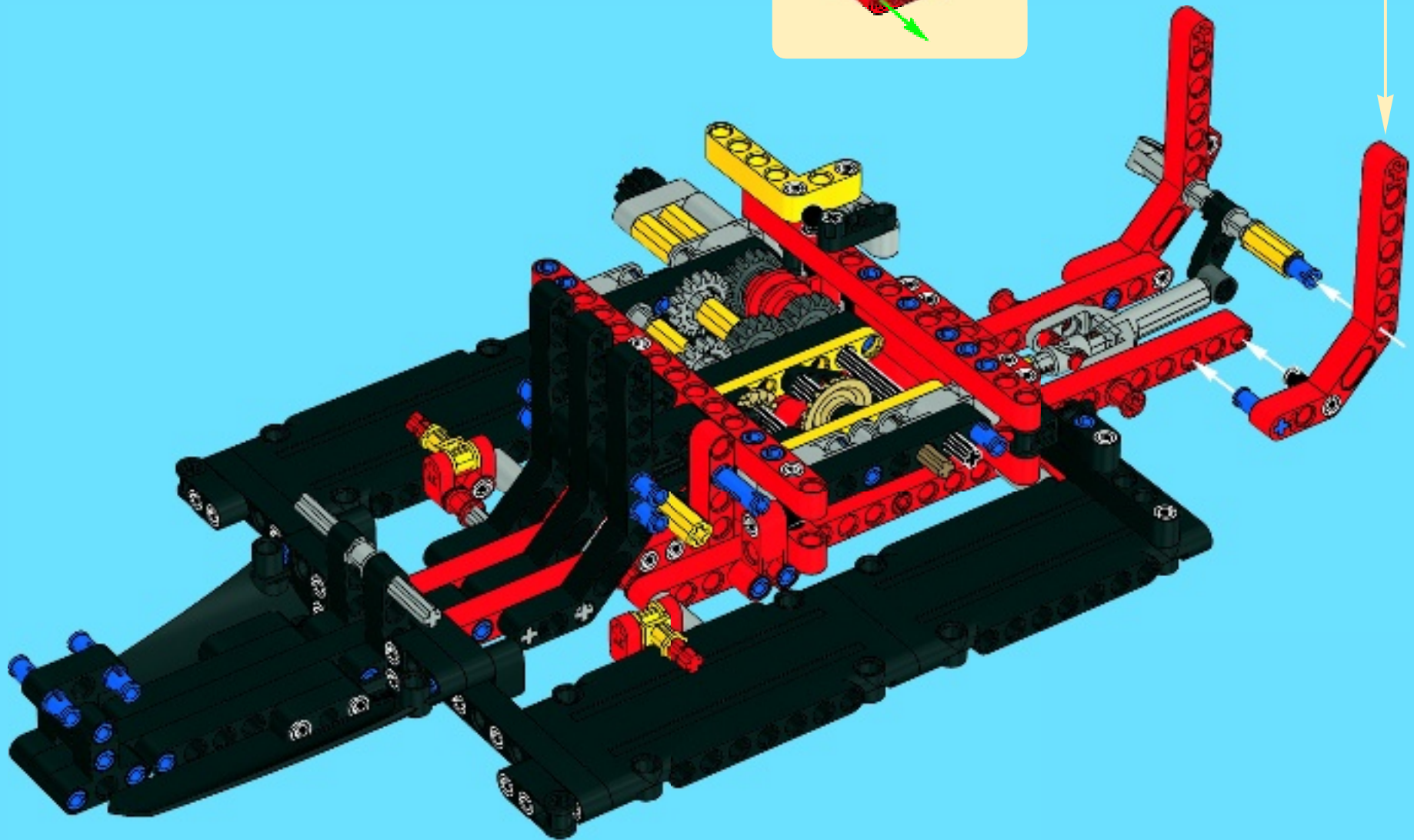
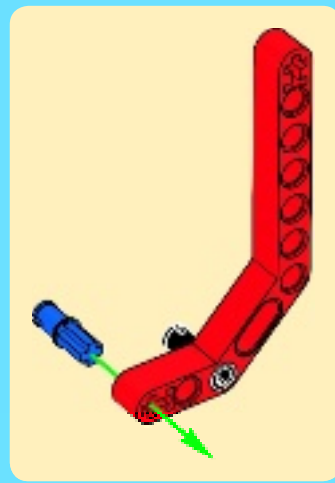

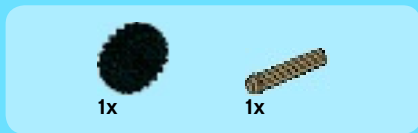
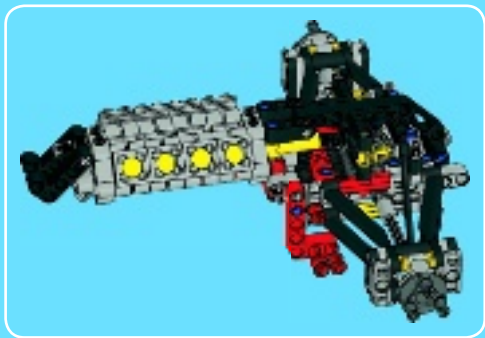

1

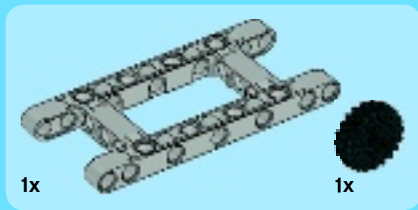
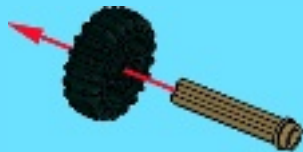

2

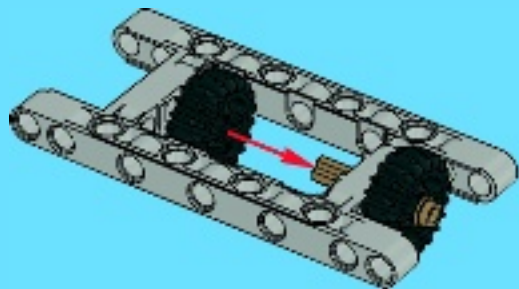

3

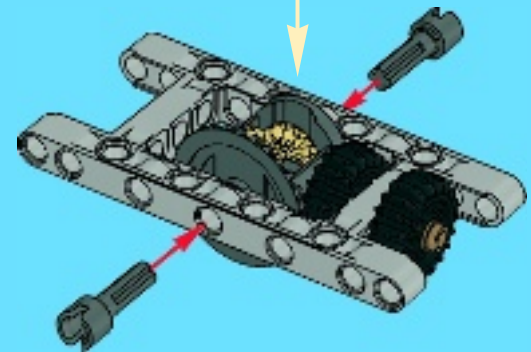
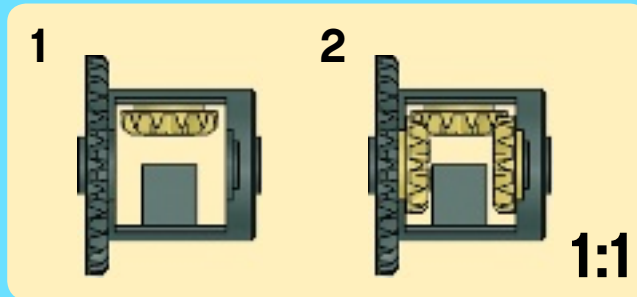

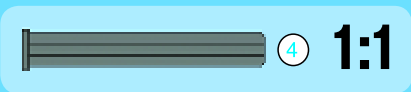
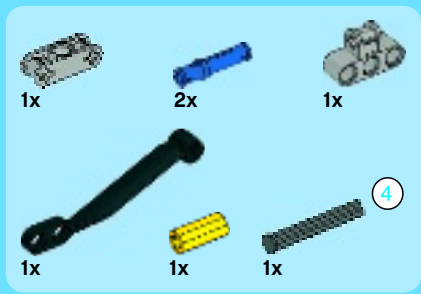

4

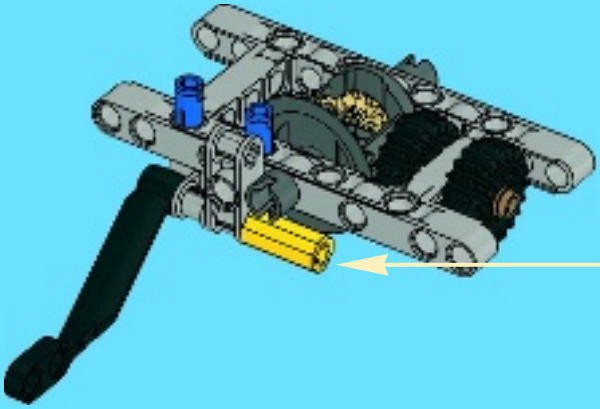
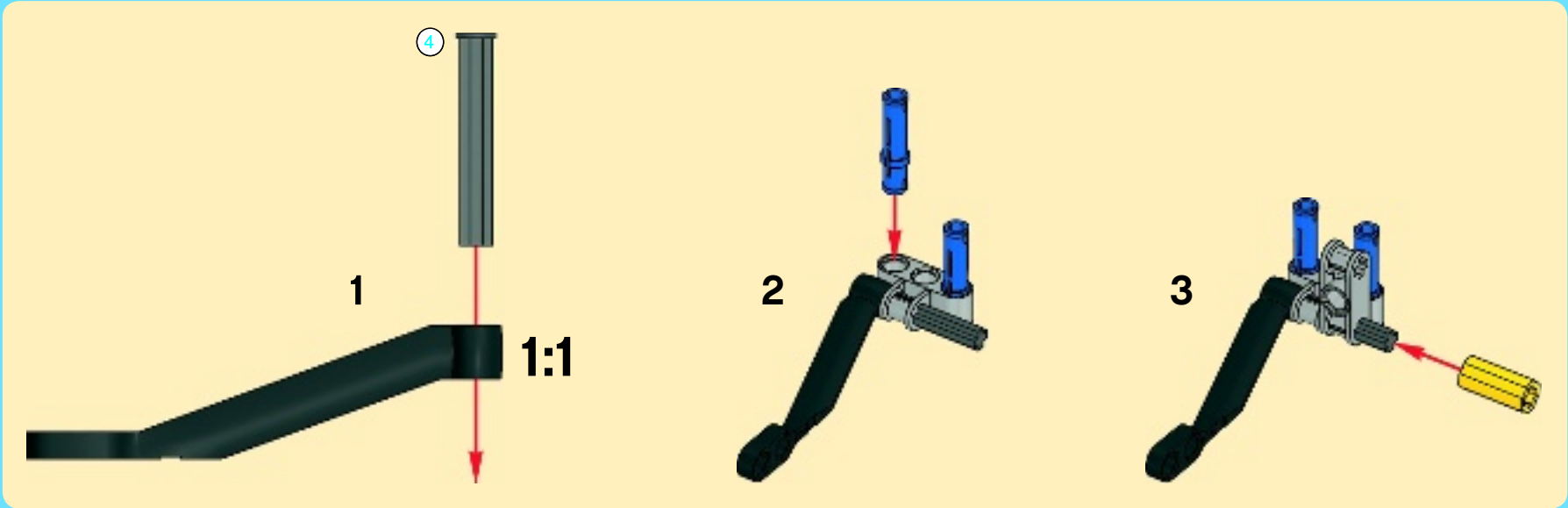

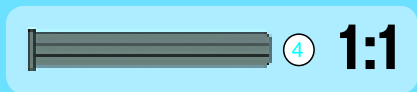
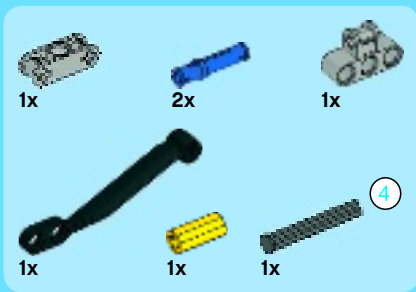

5

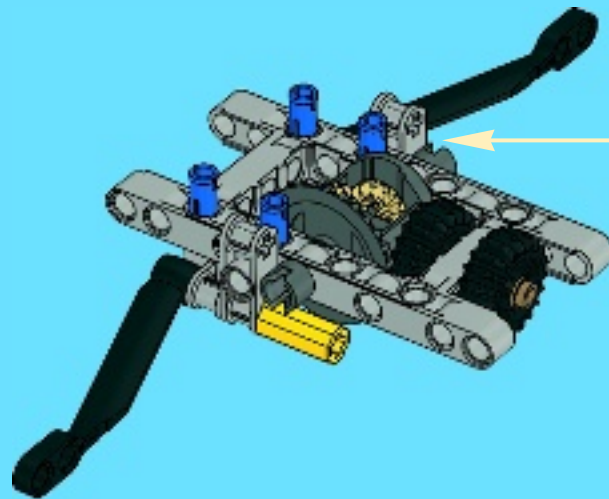
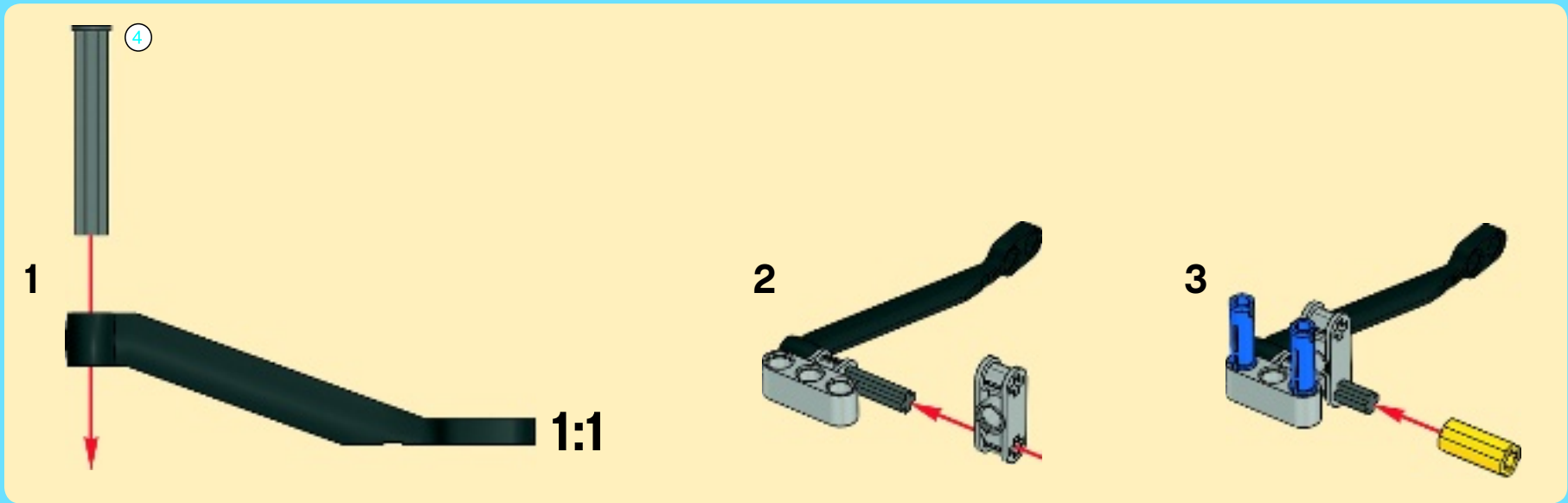



2x

6

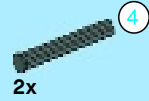
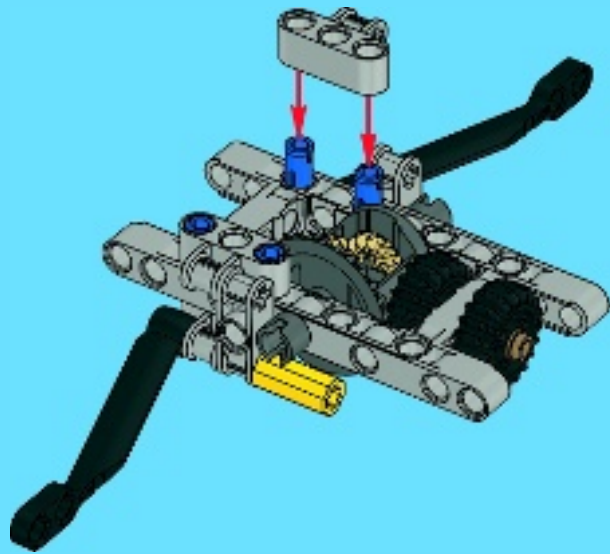

2x



2x

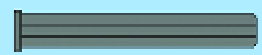

④ 1:1

7

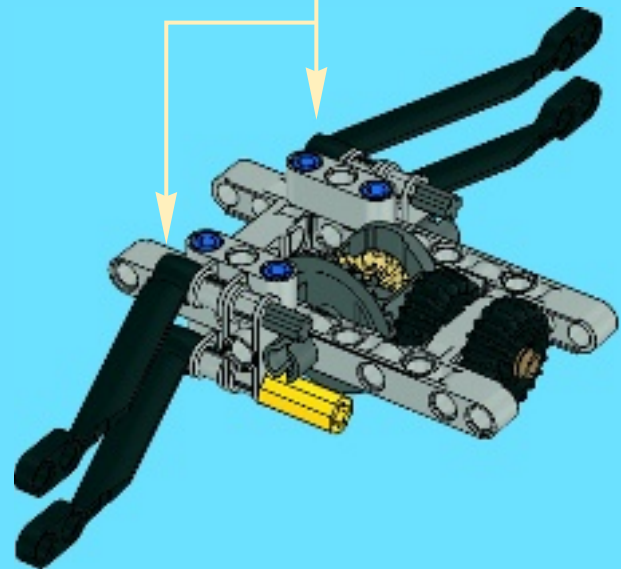
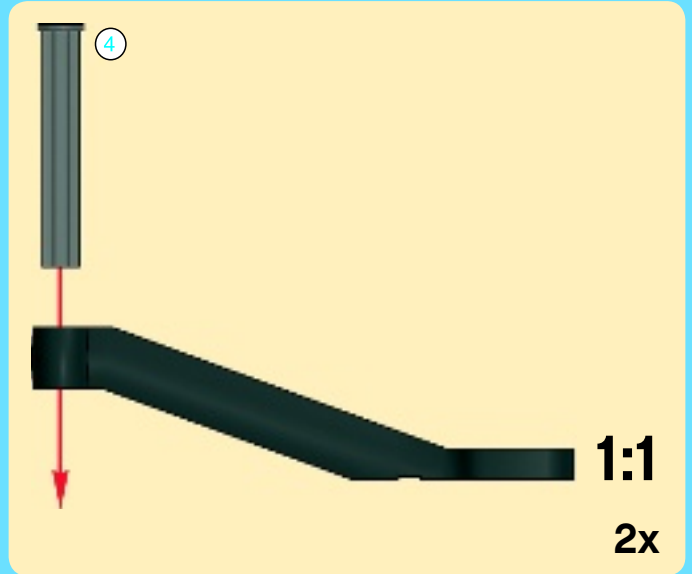



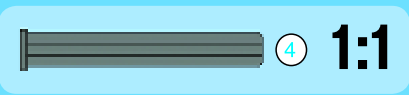
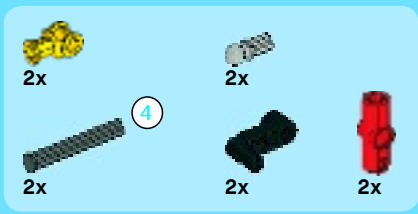

8

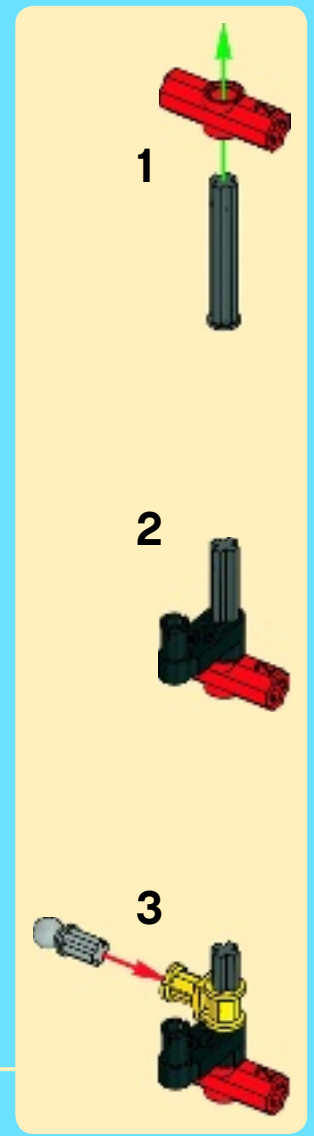
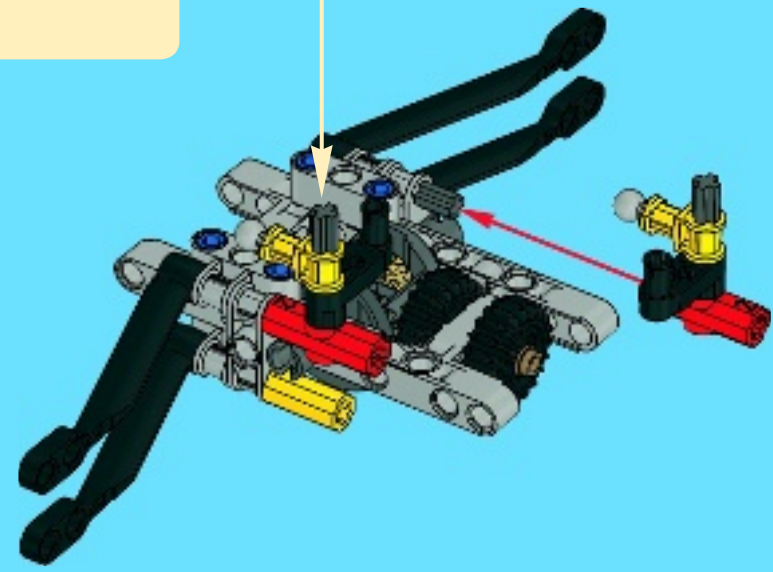
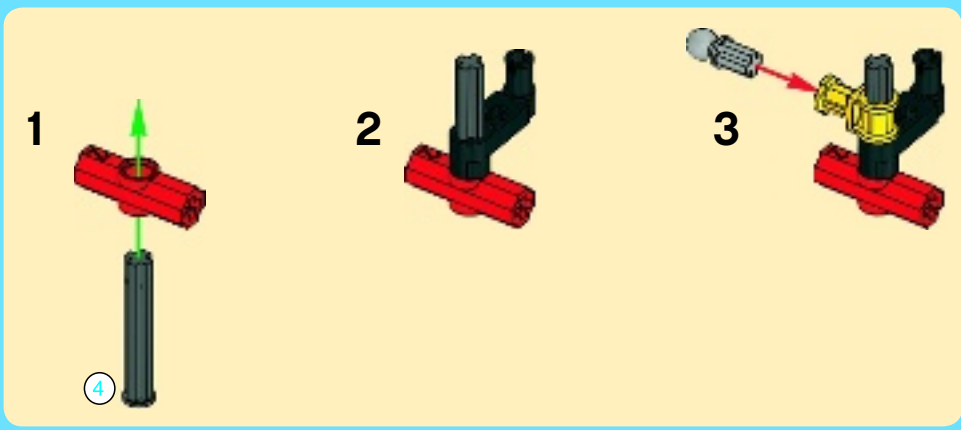

2x

2x

2x

9

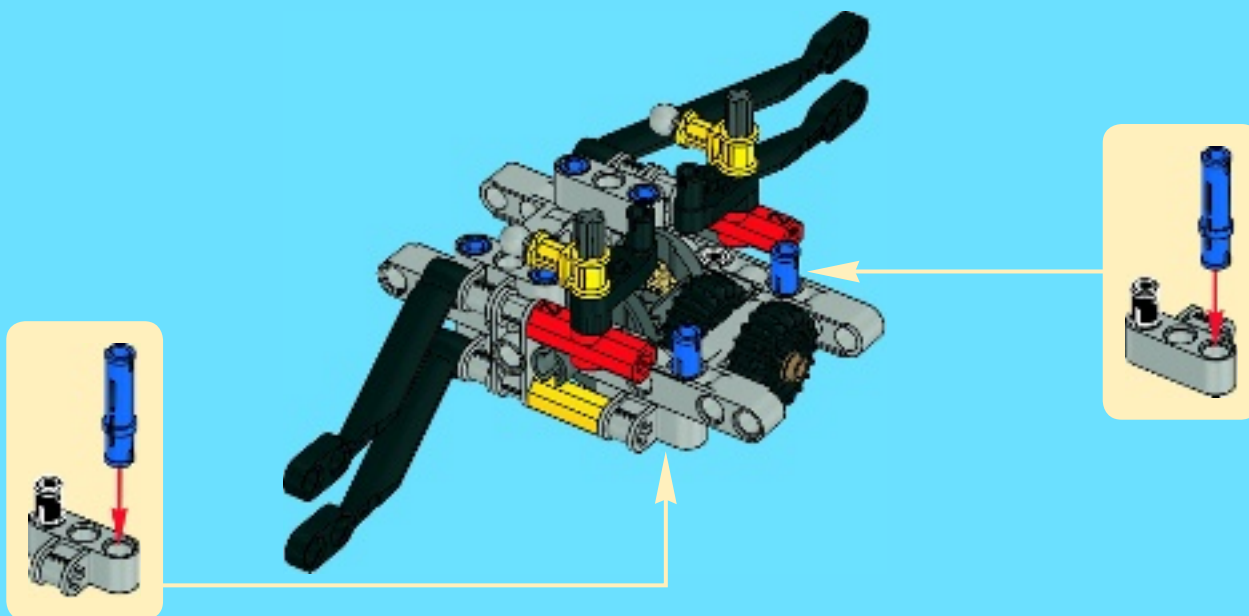

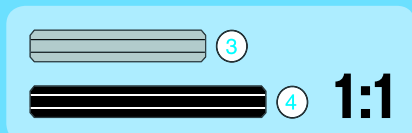
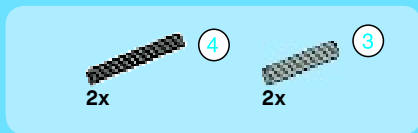

10

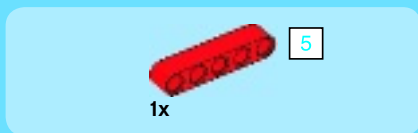
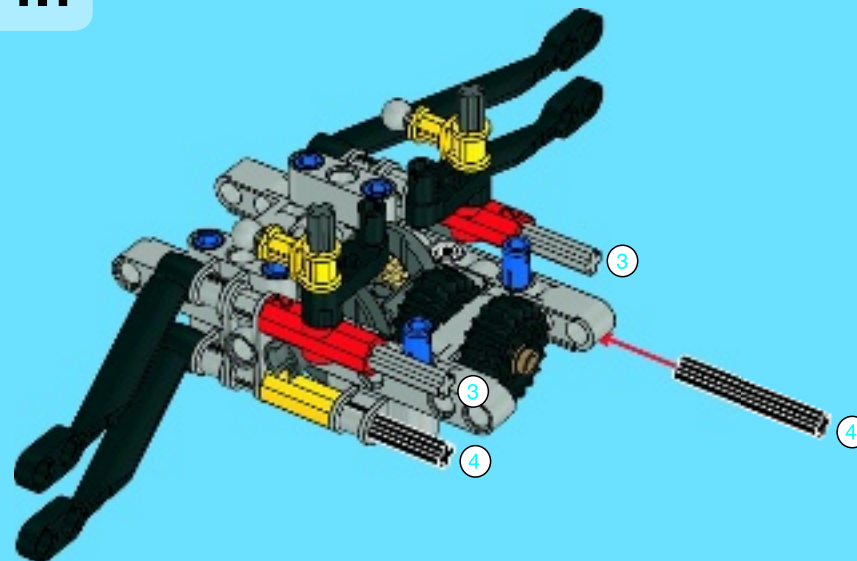

11

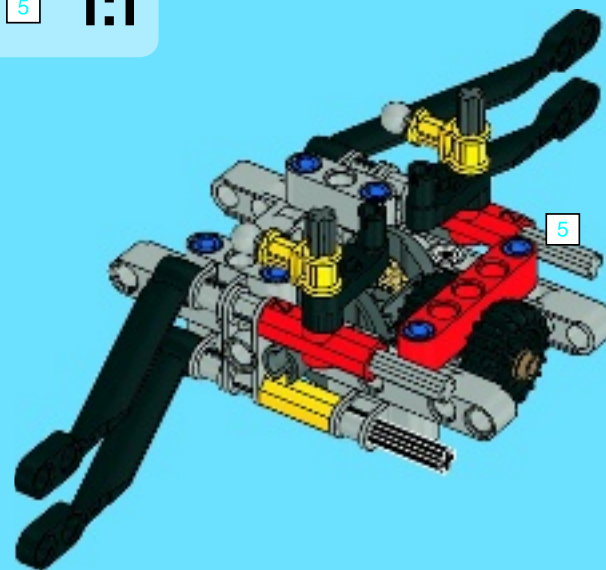

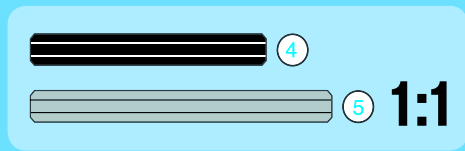
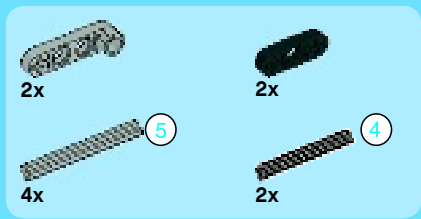

# 12

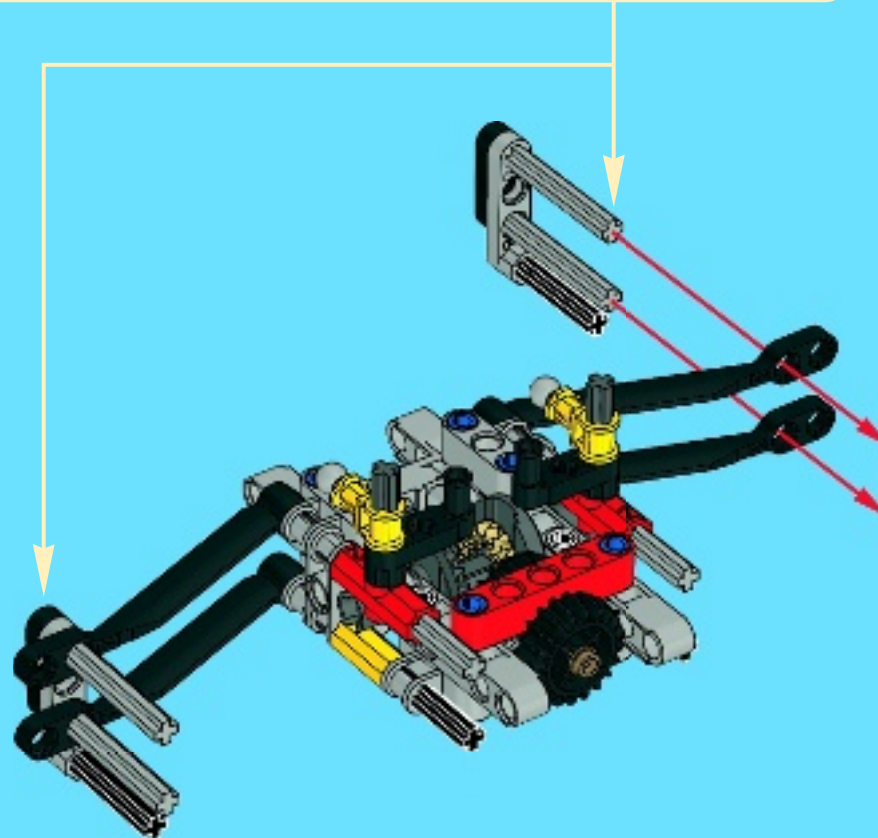
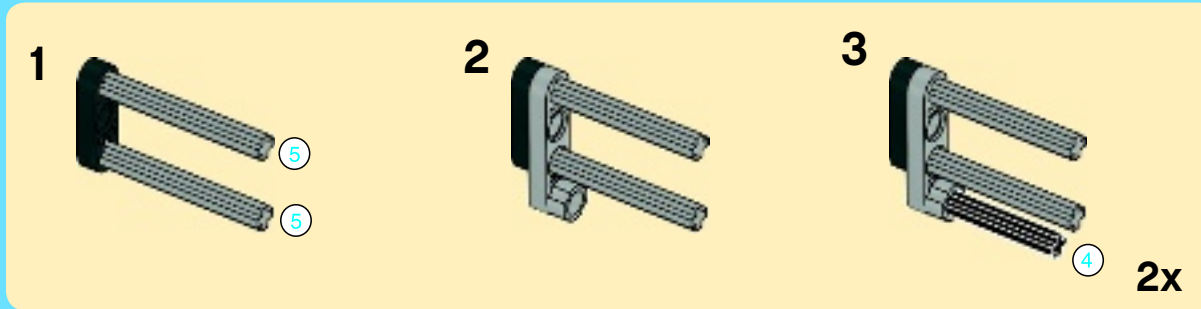



13

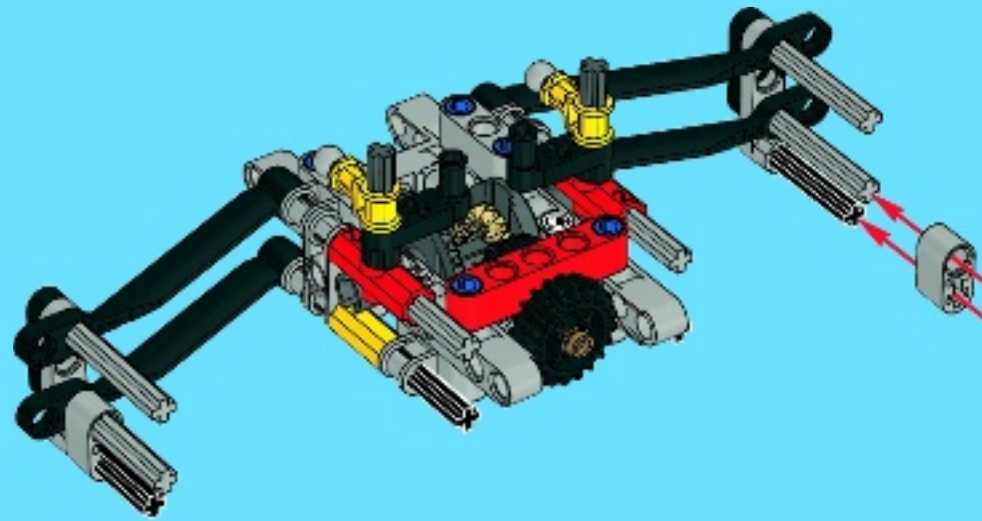

14

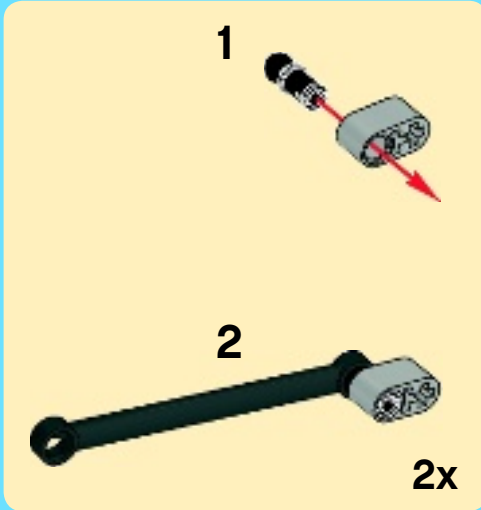
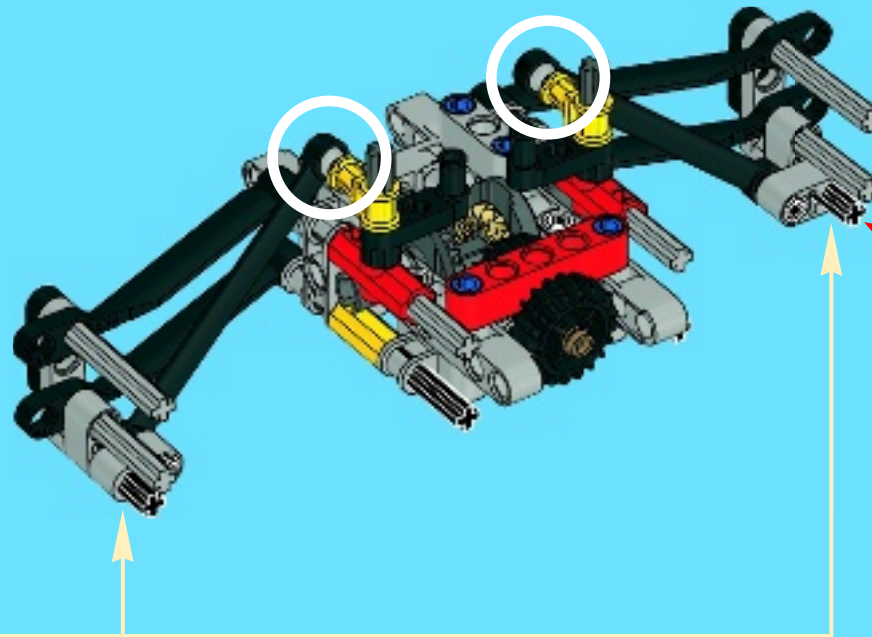



2x

15

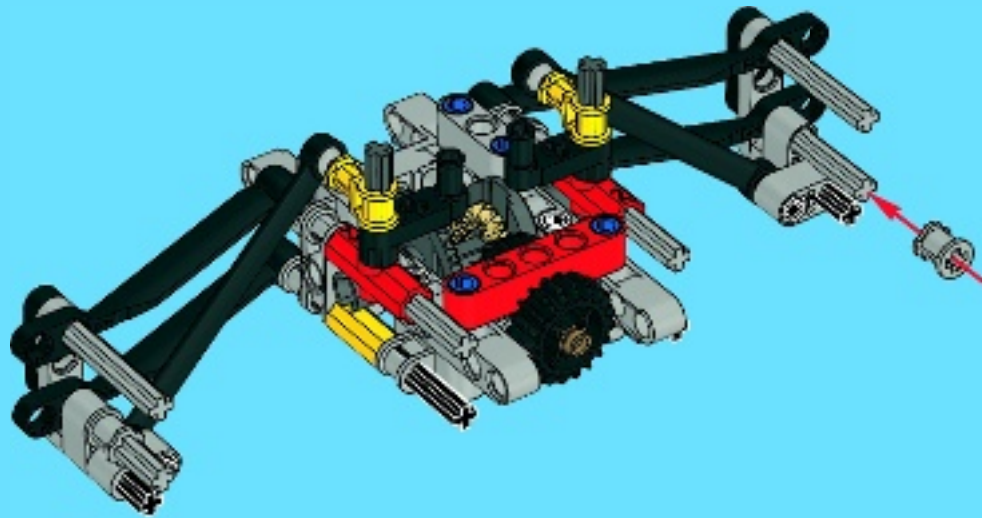

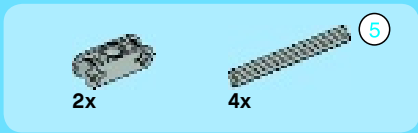

16

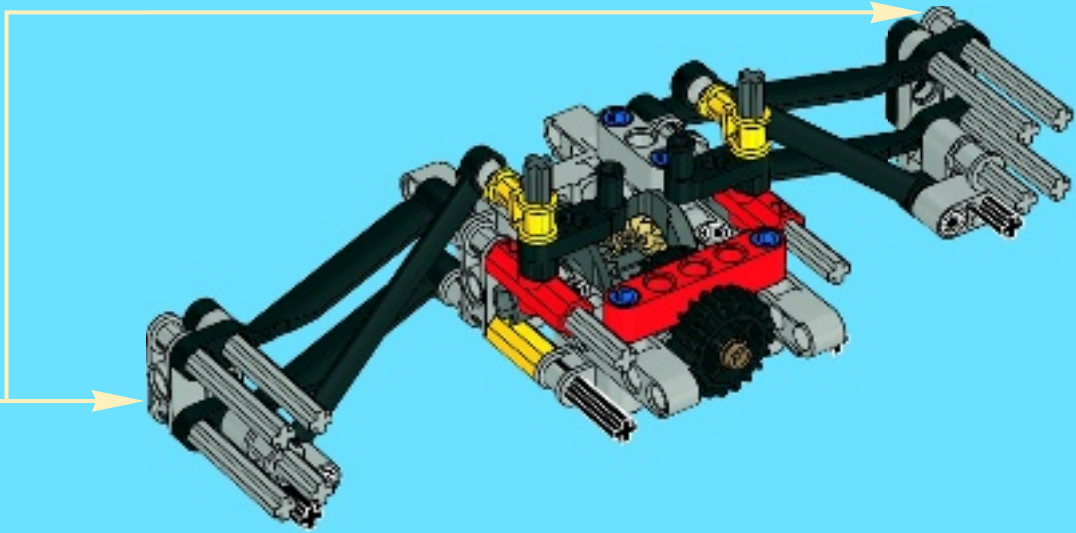
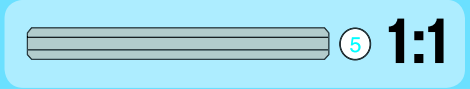
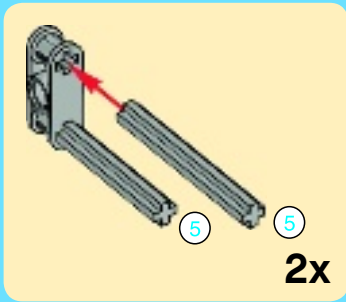

17

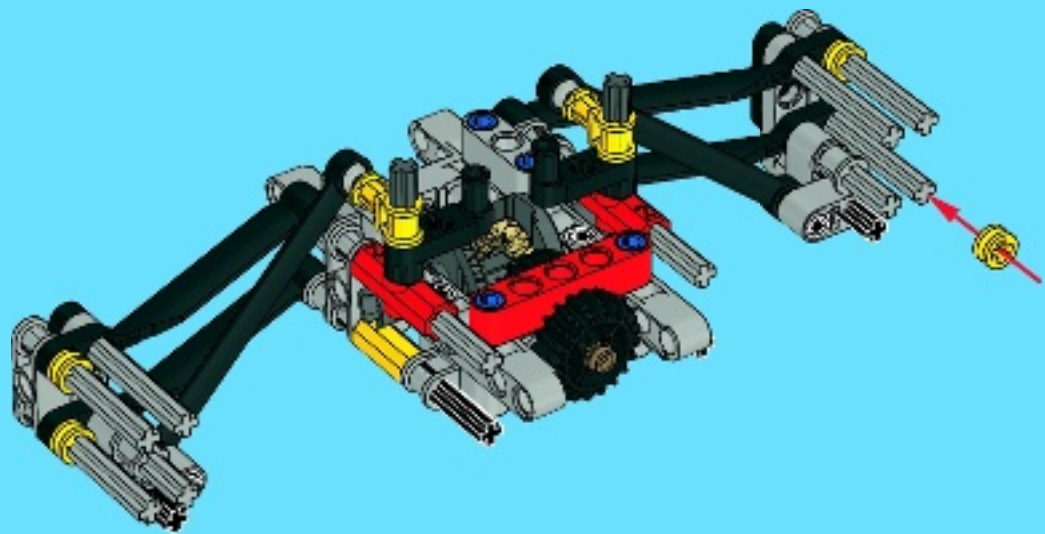

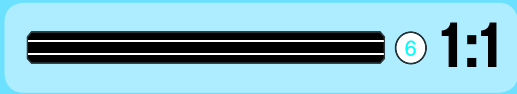
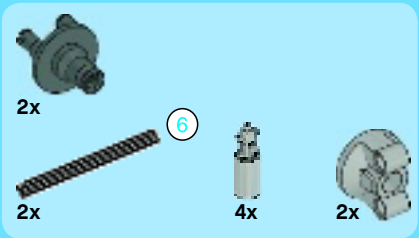

18

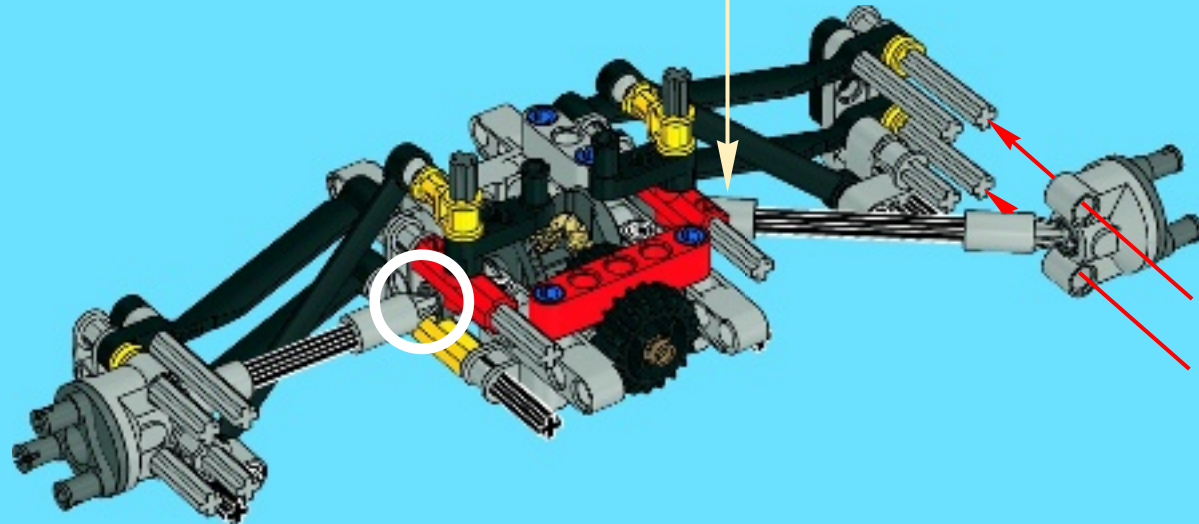
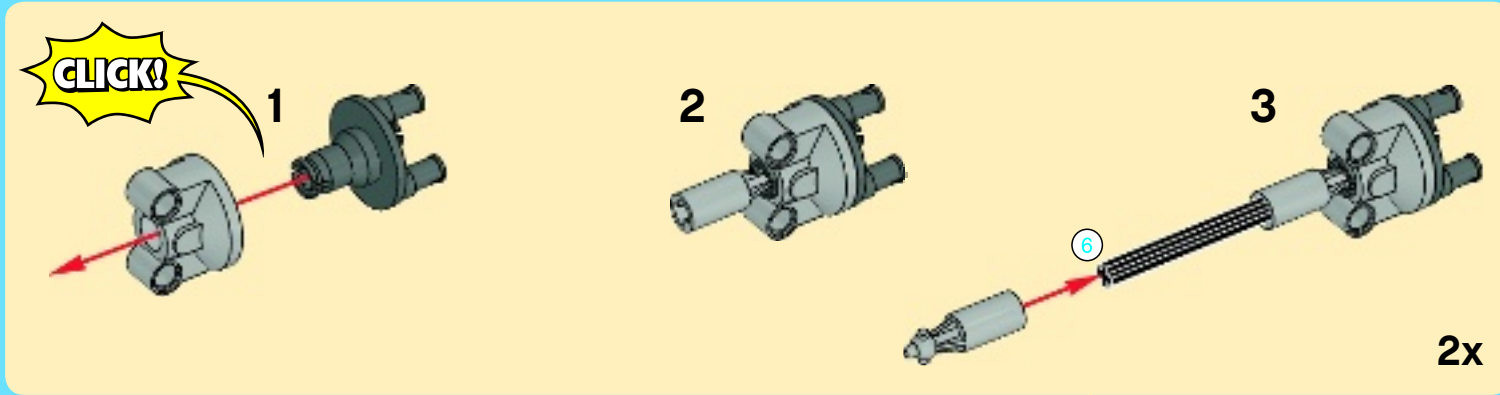





4x

19

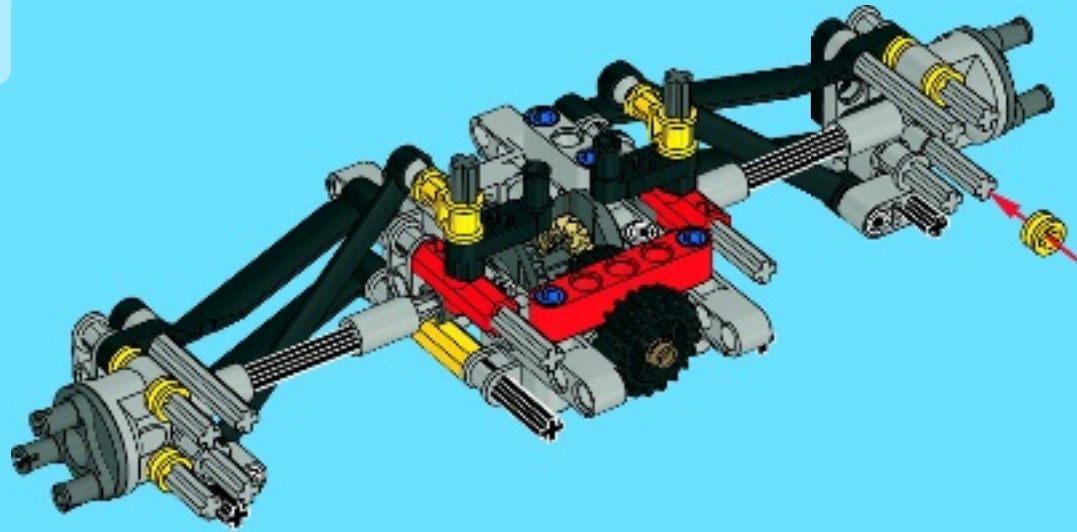

2x

20

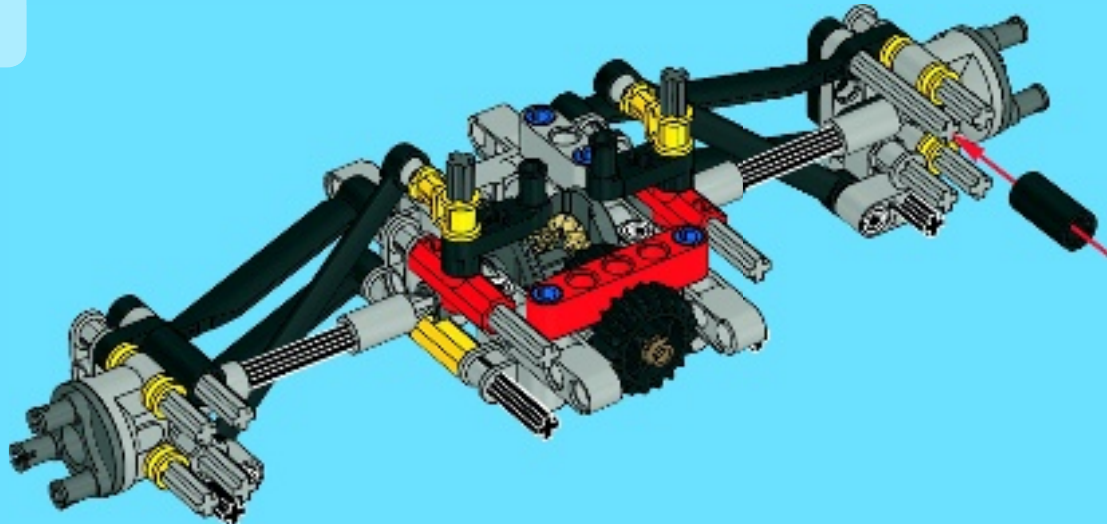



21

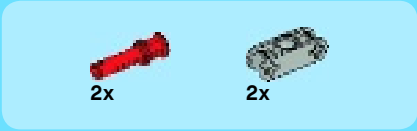
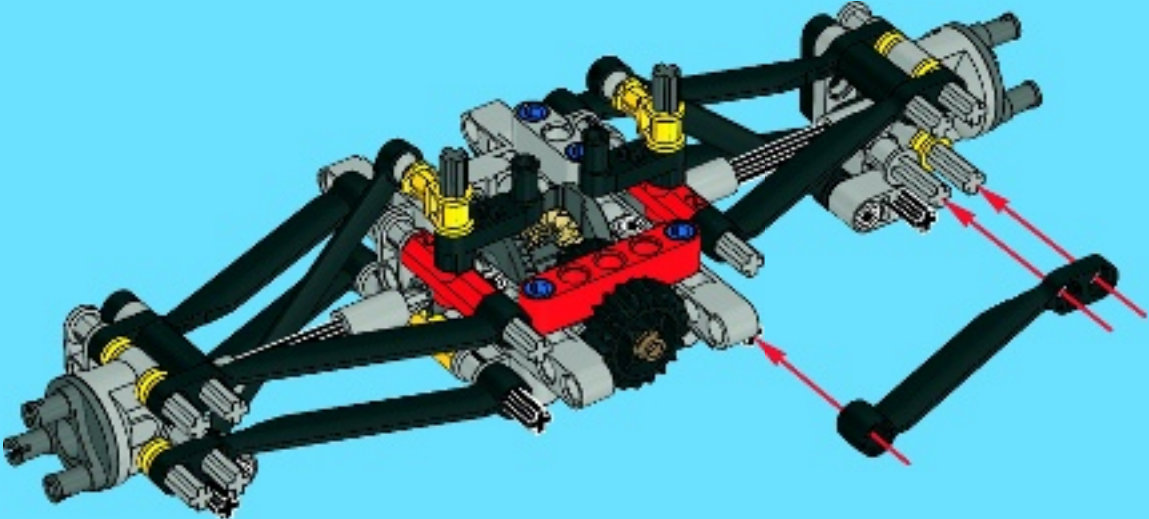

22

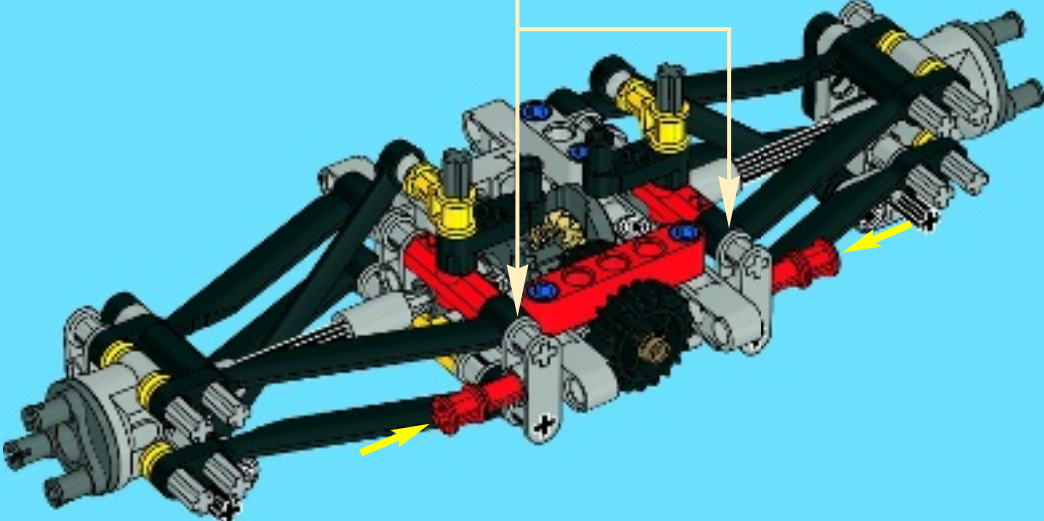
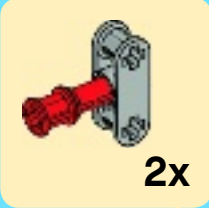



23

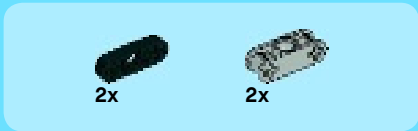
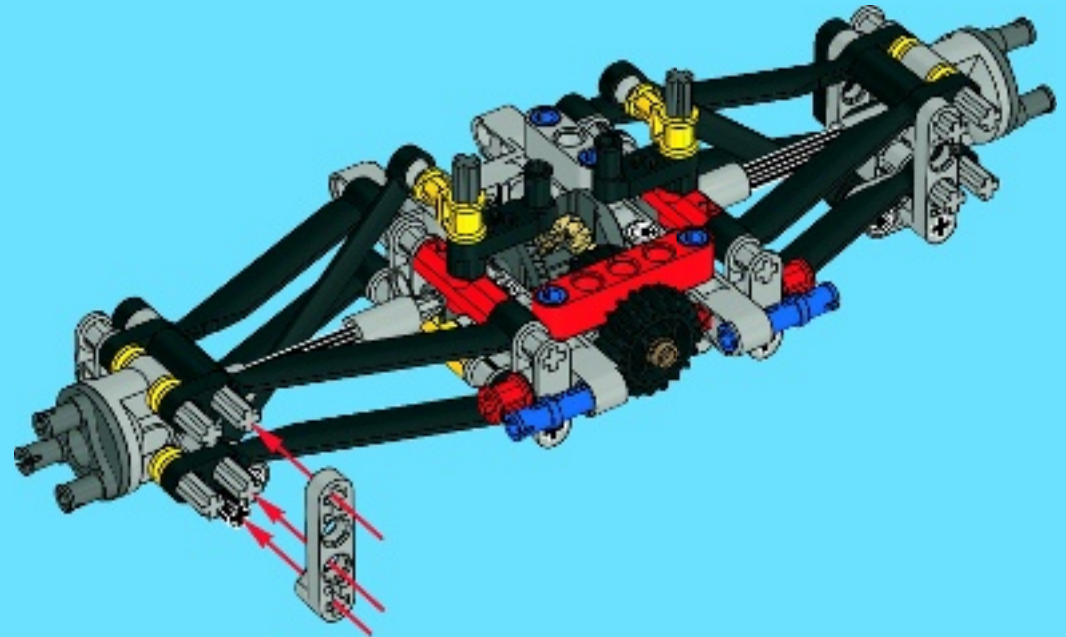

24

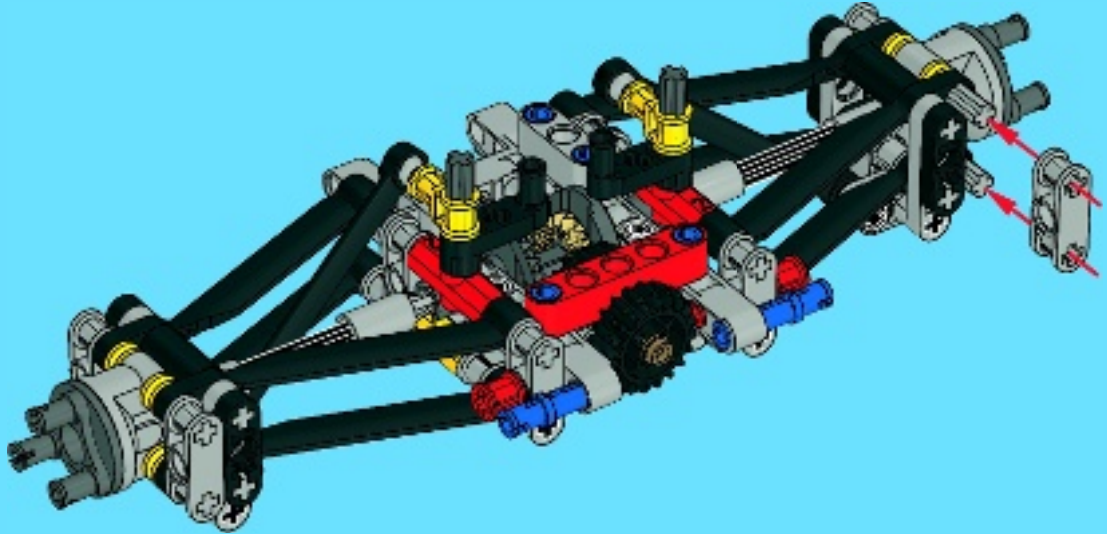

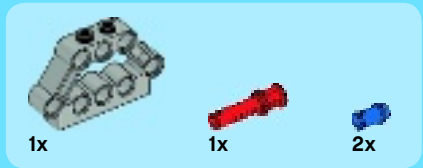
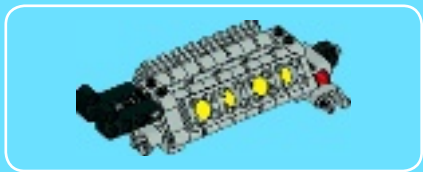

1

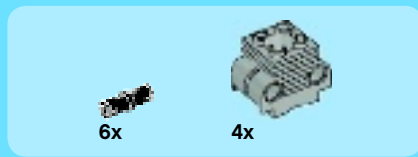
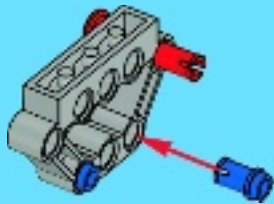

2

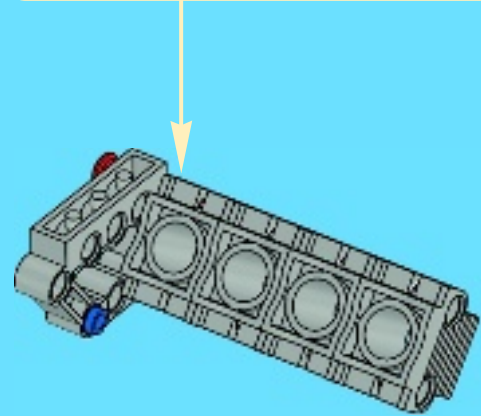
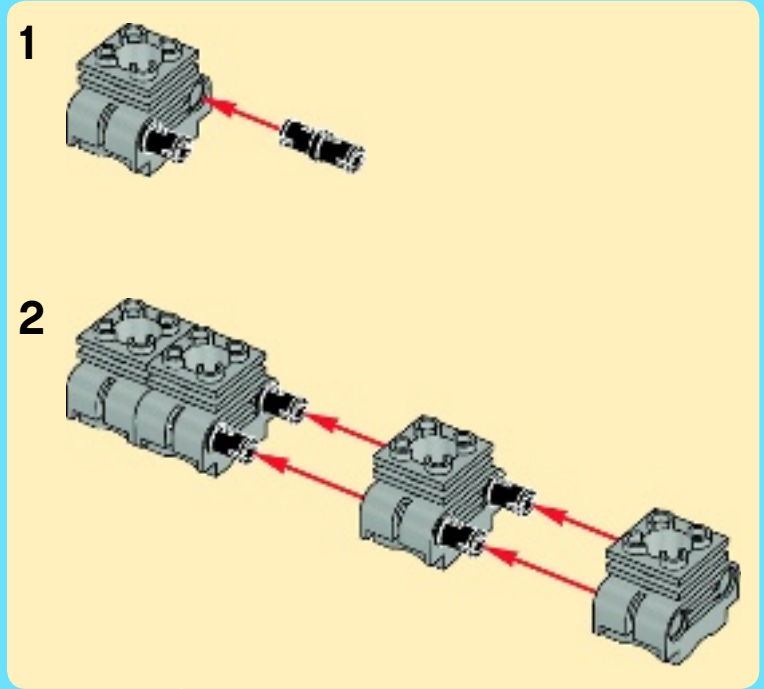

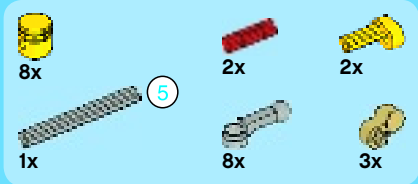

3

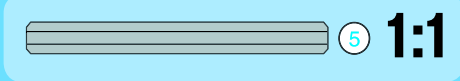
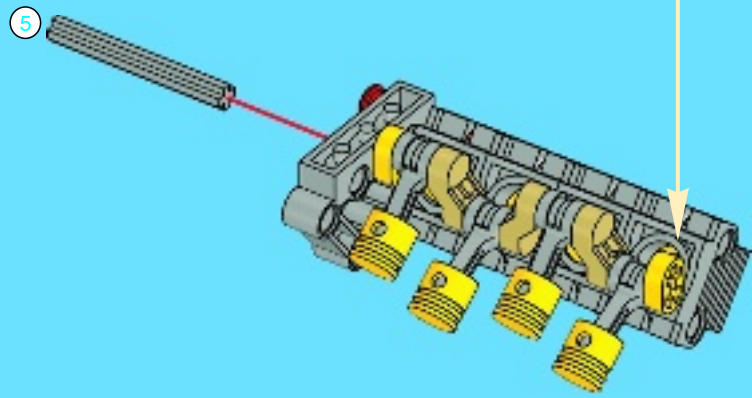
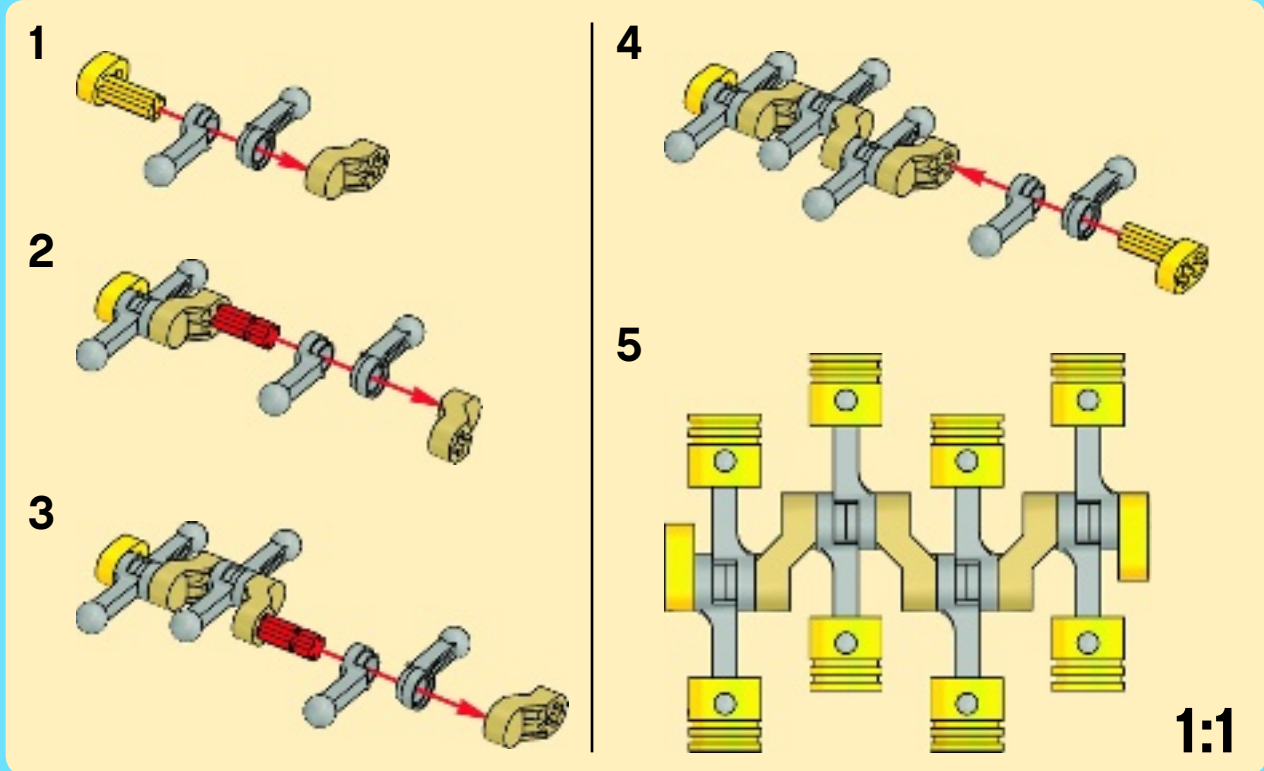



4

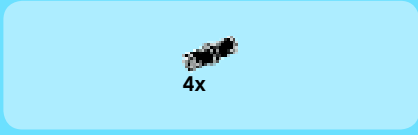
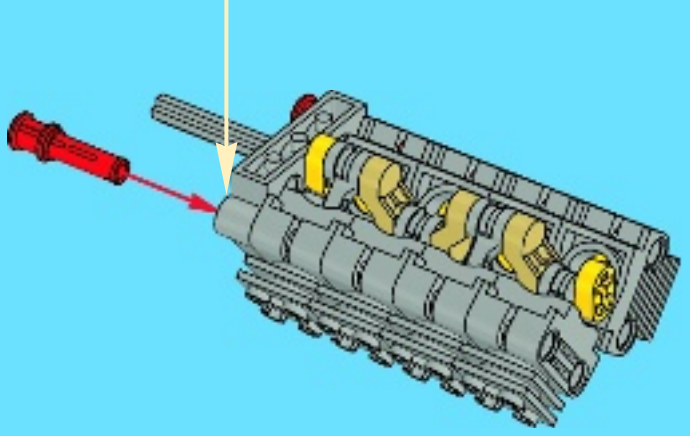
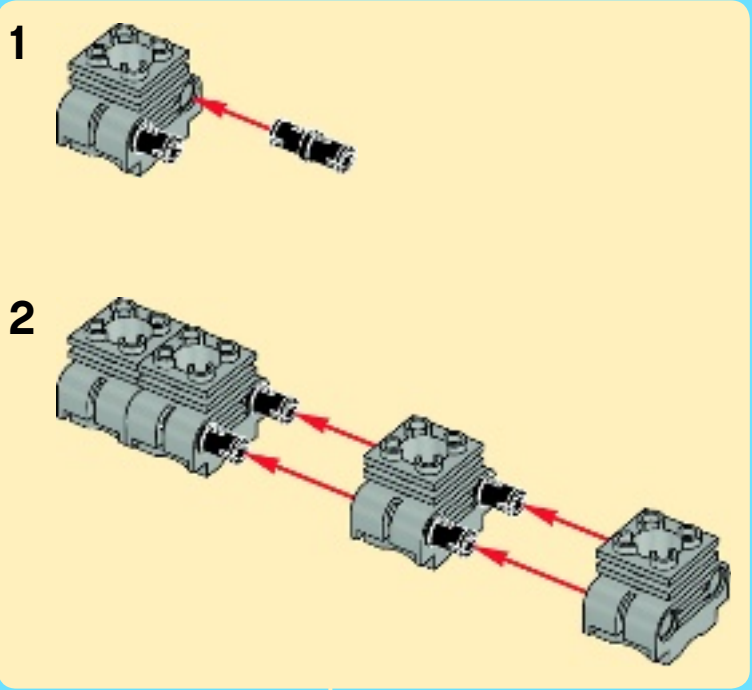

5

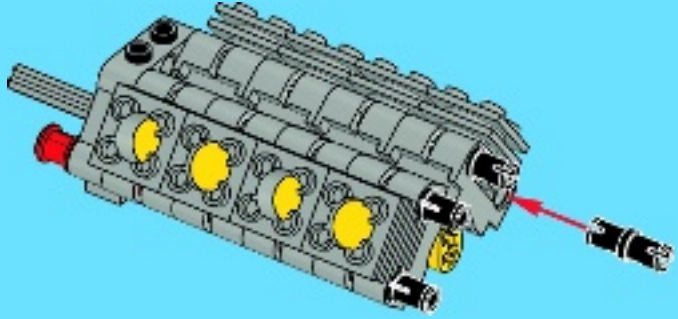

6

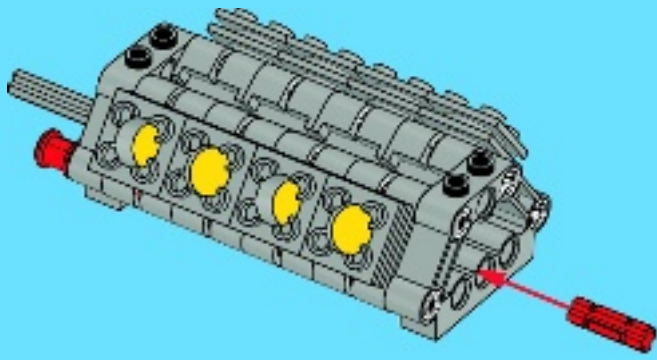

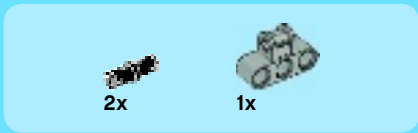

7

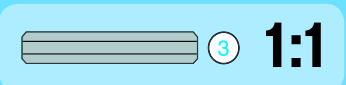
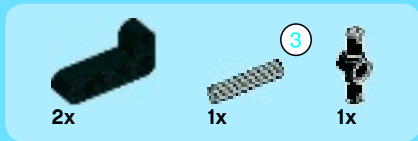
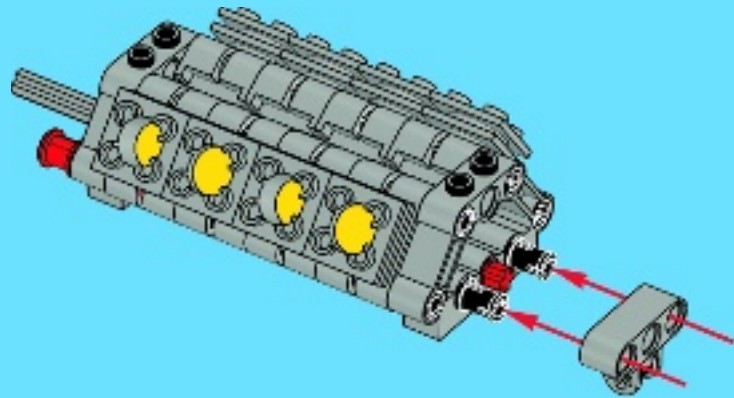

8

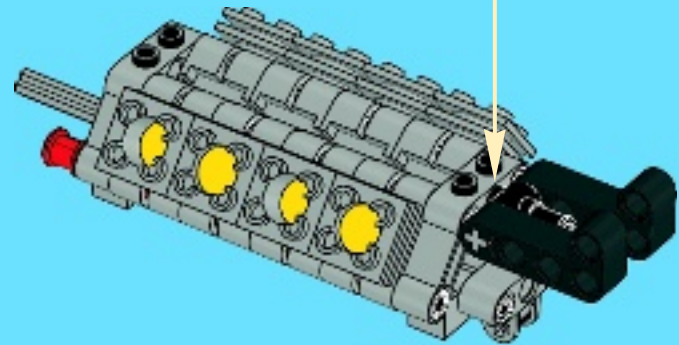

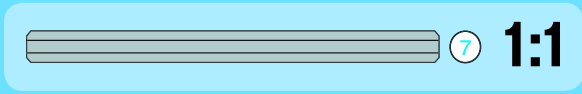
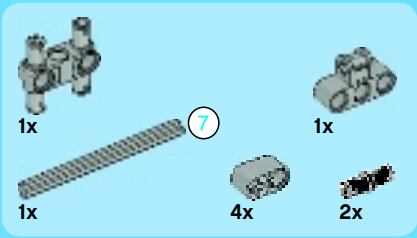

9

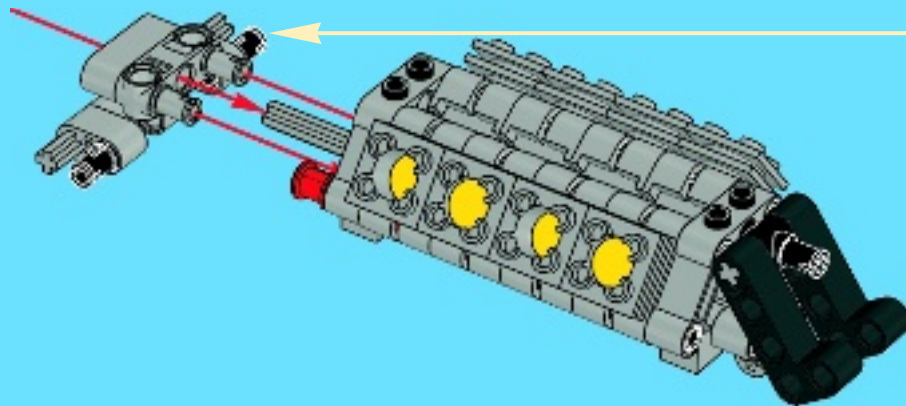
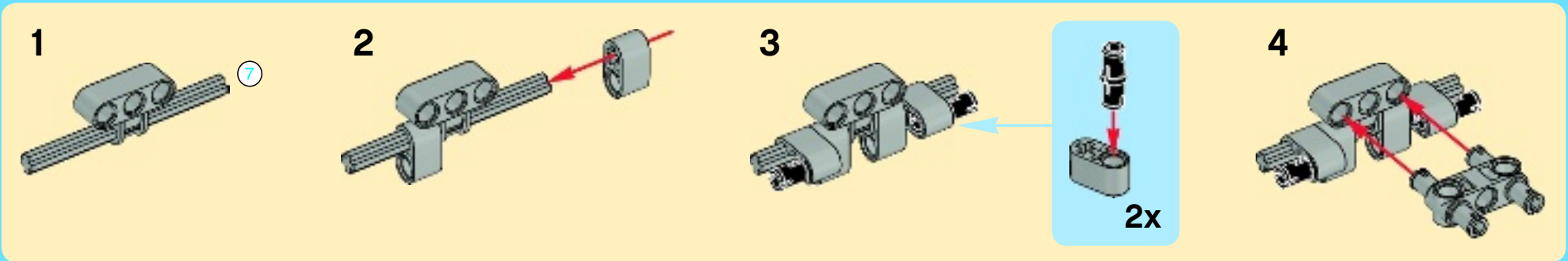





1x

10

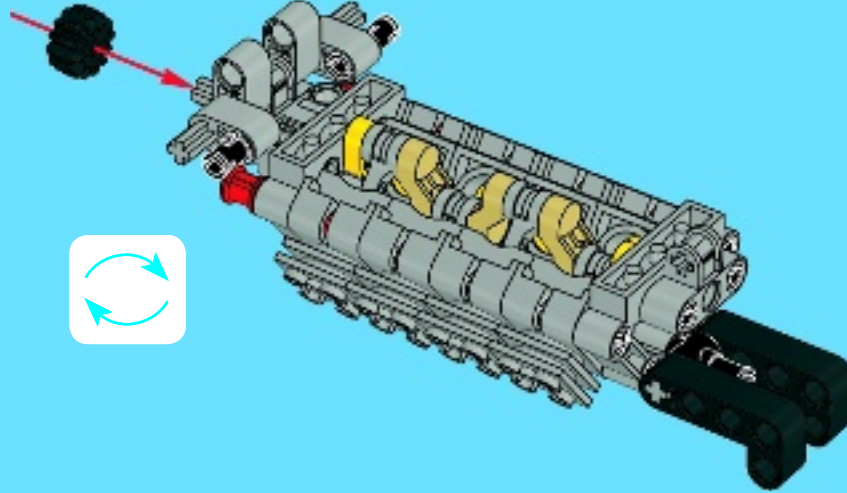

25

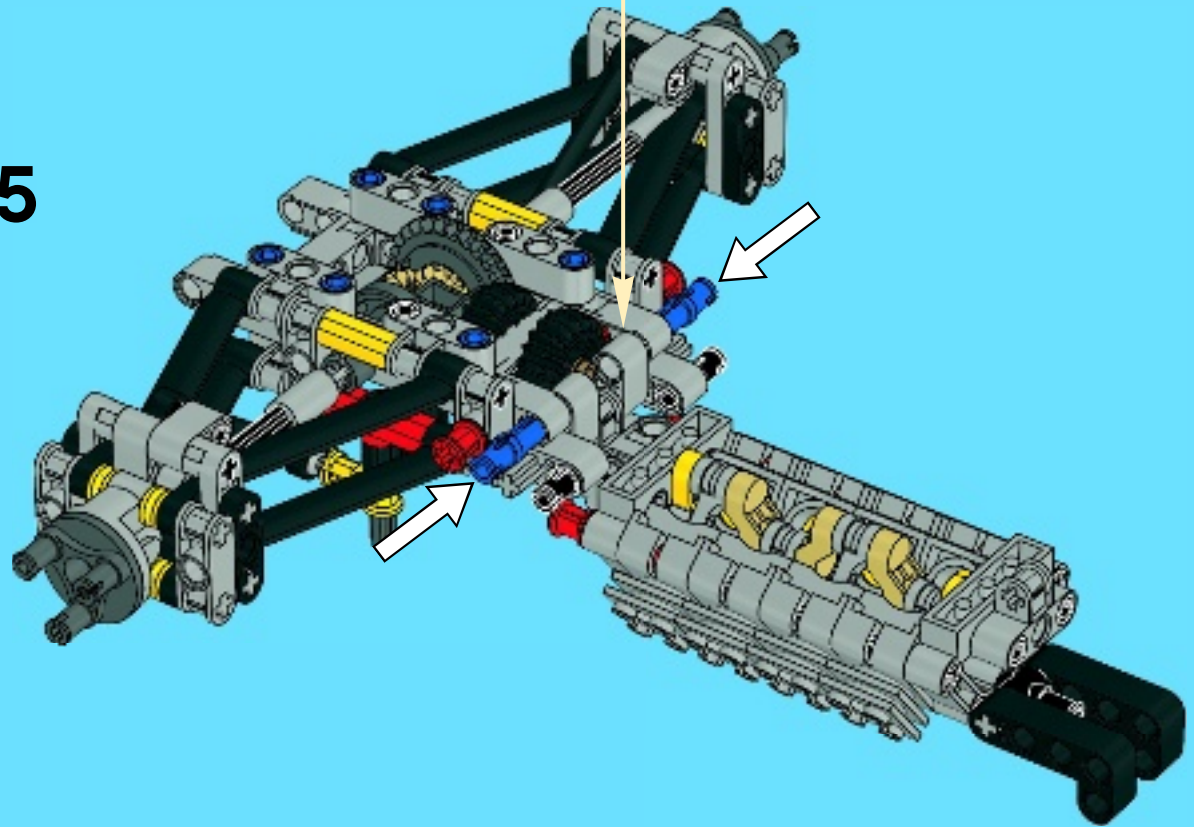



26

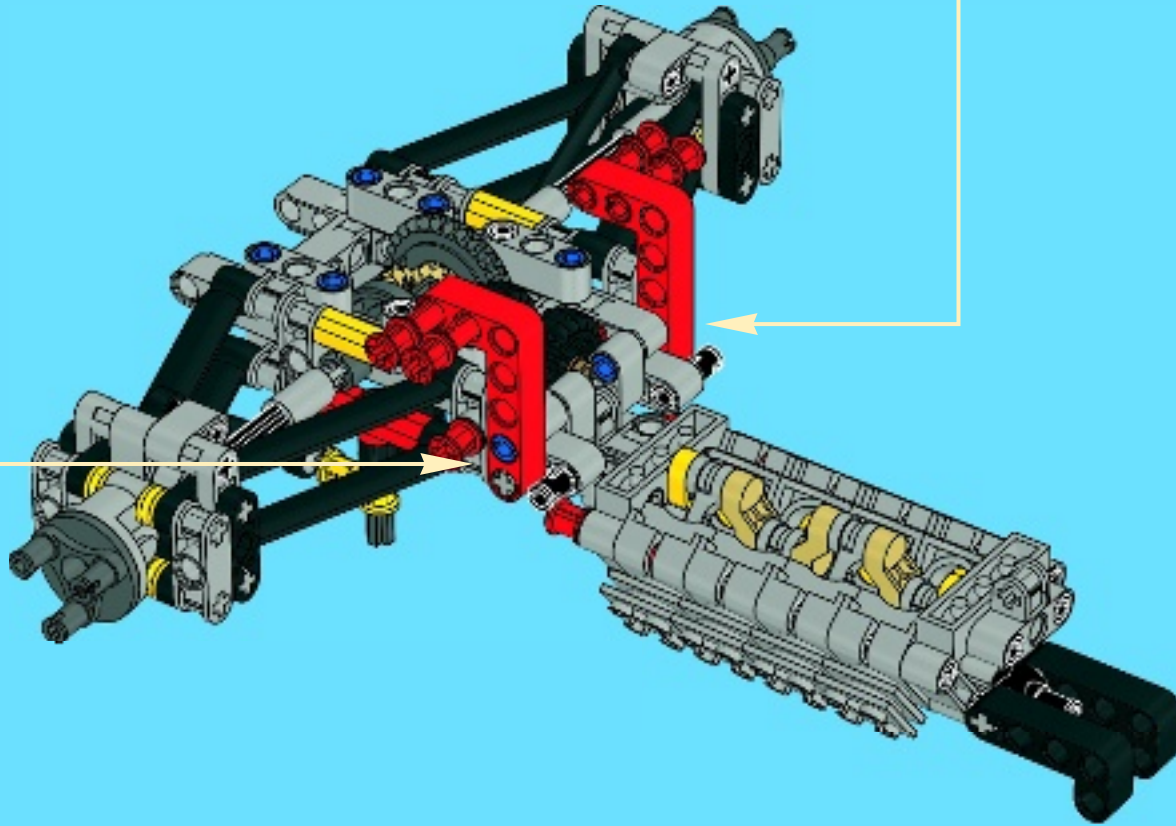

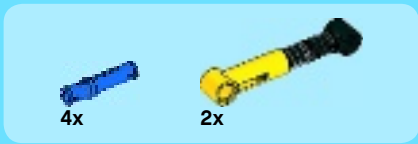

27

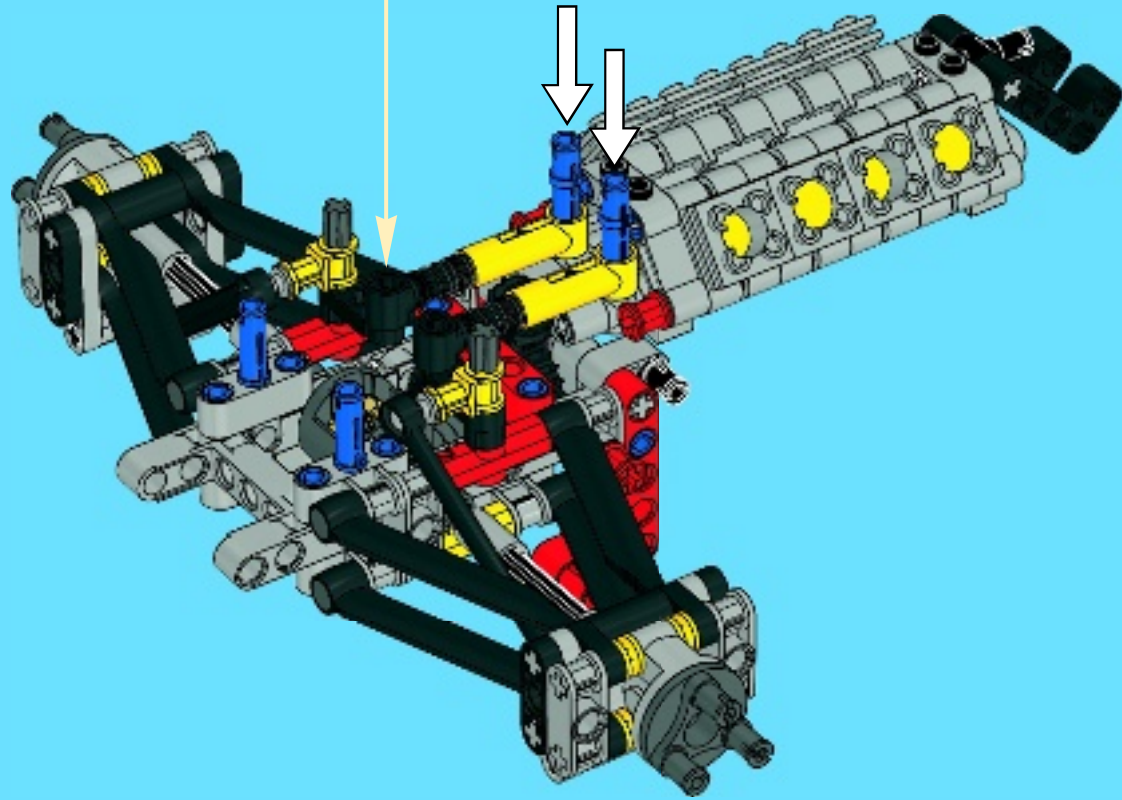
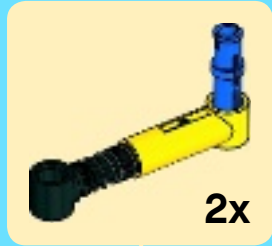

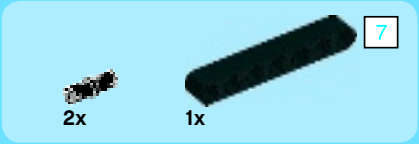

28

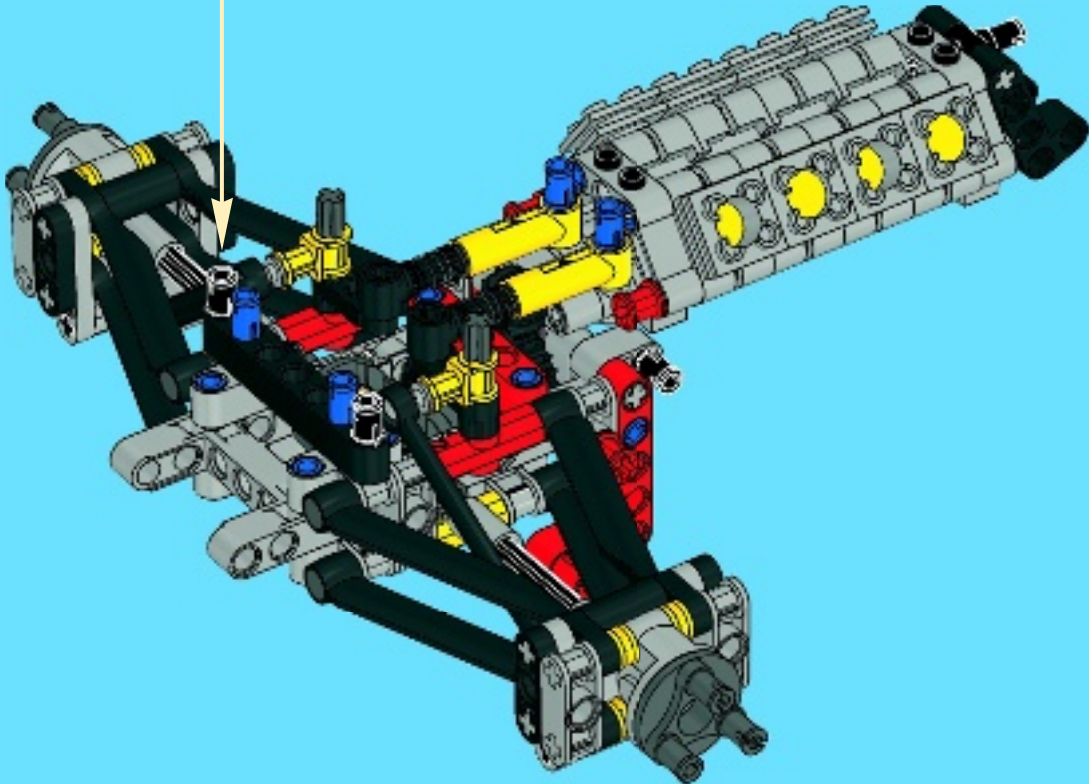
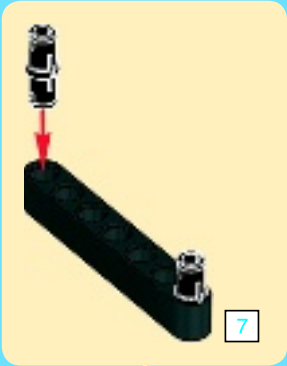

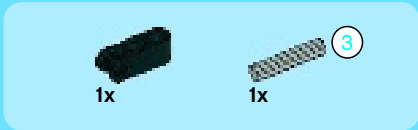

1



2

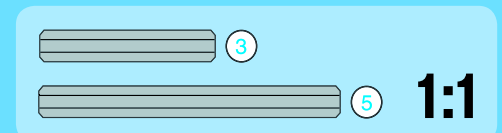
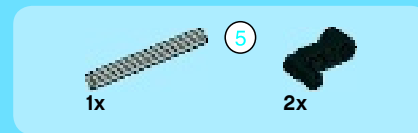

3



4





5

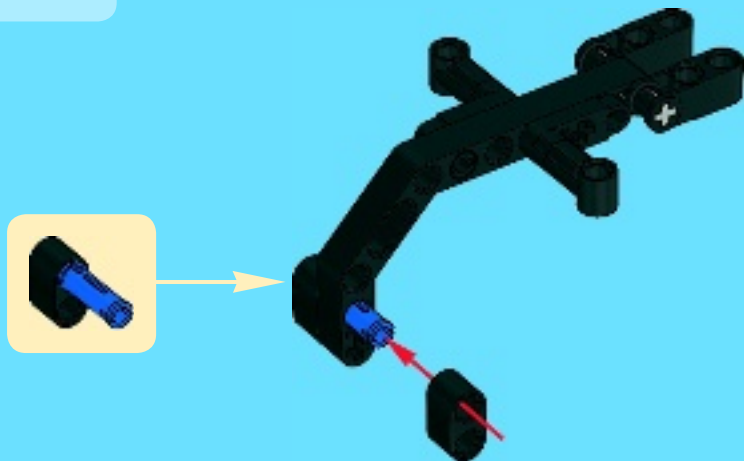

29

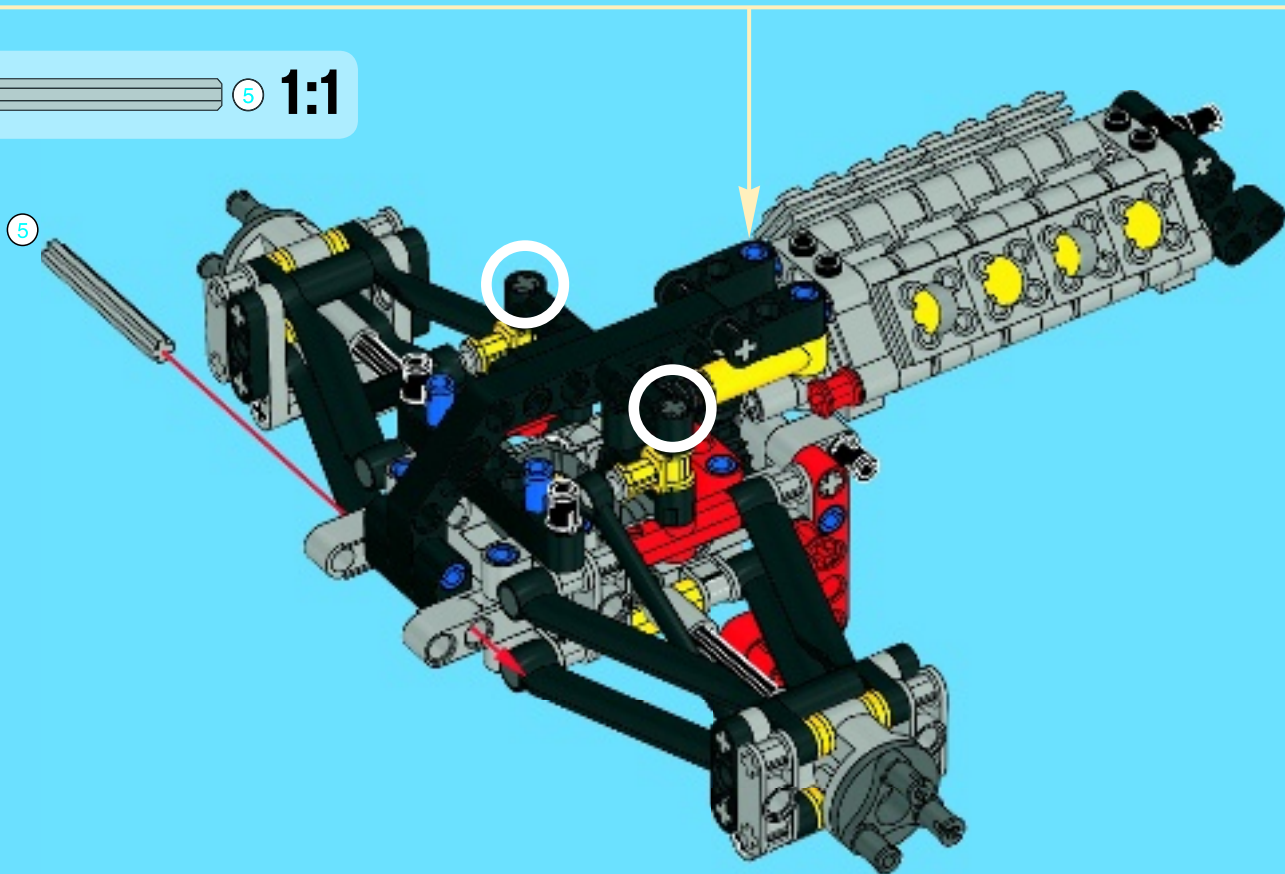

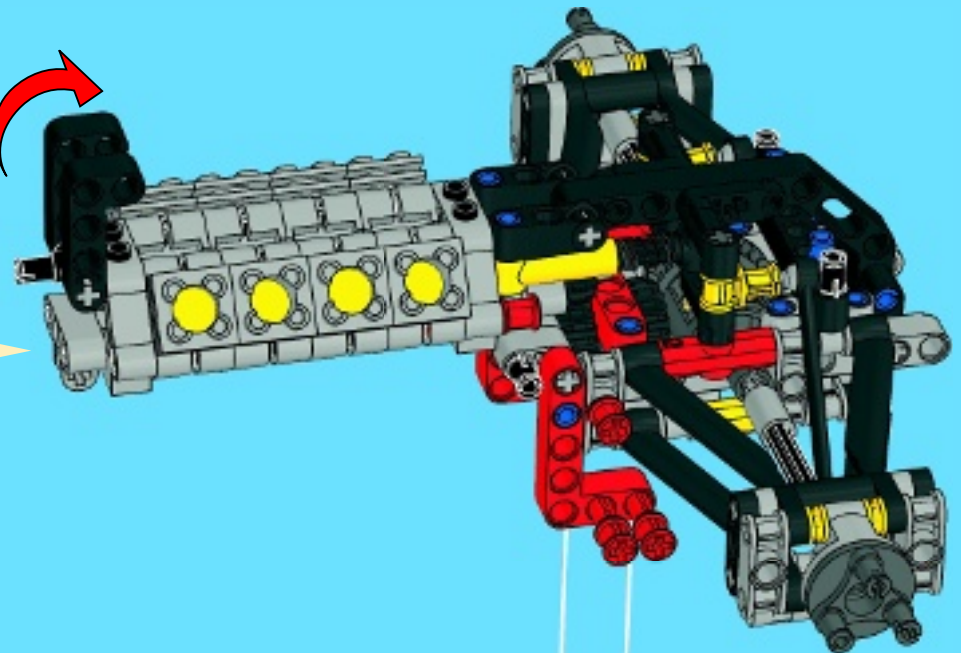

40

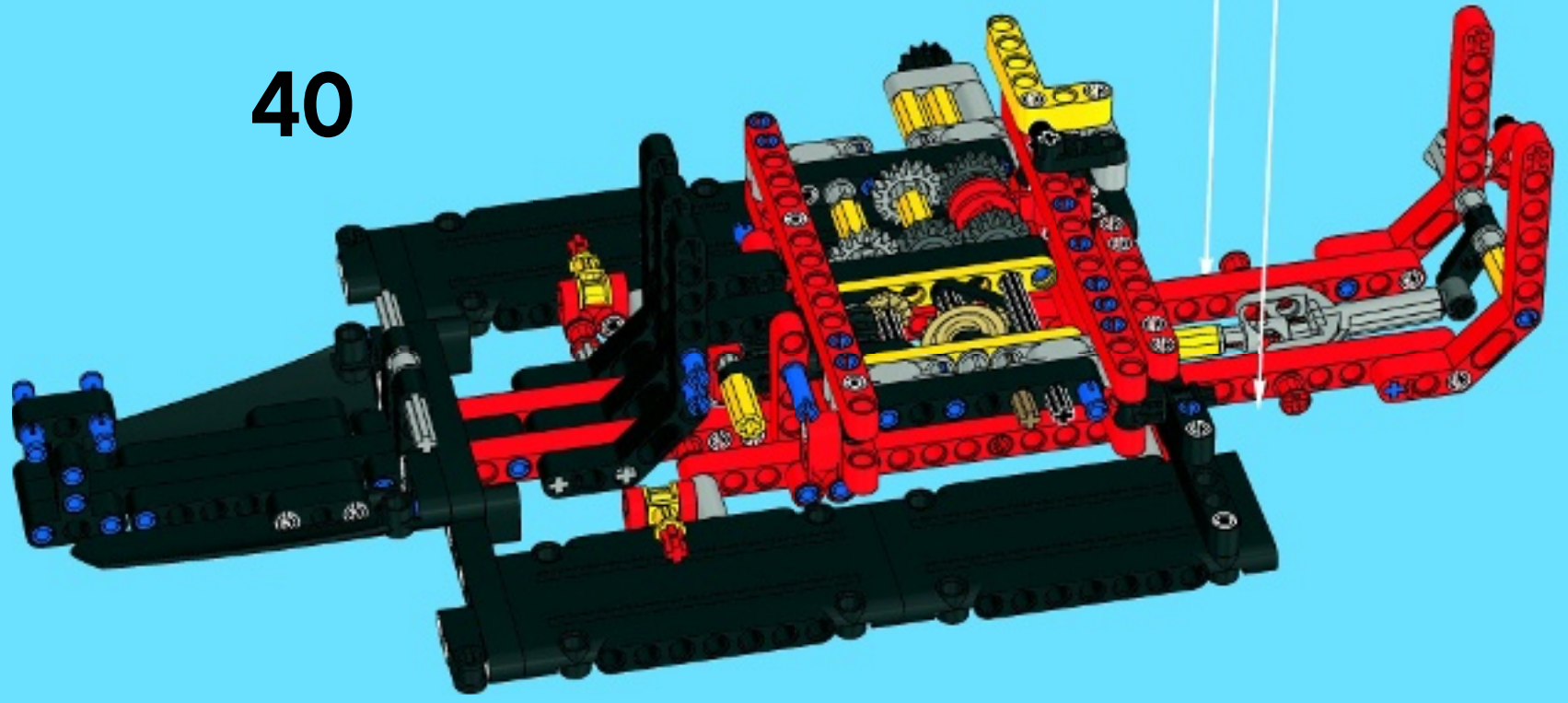

41

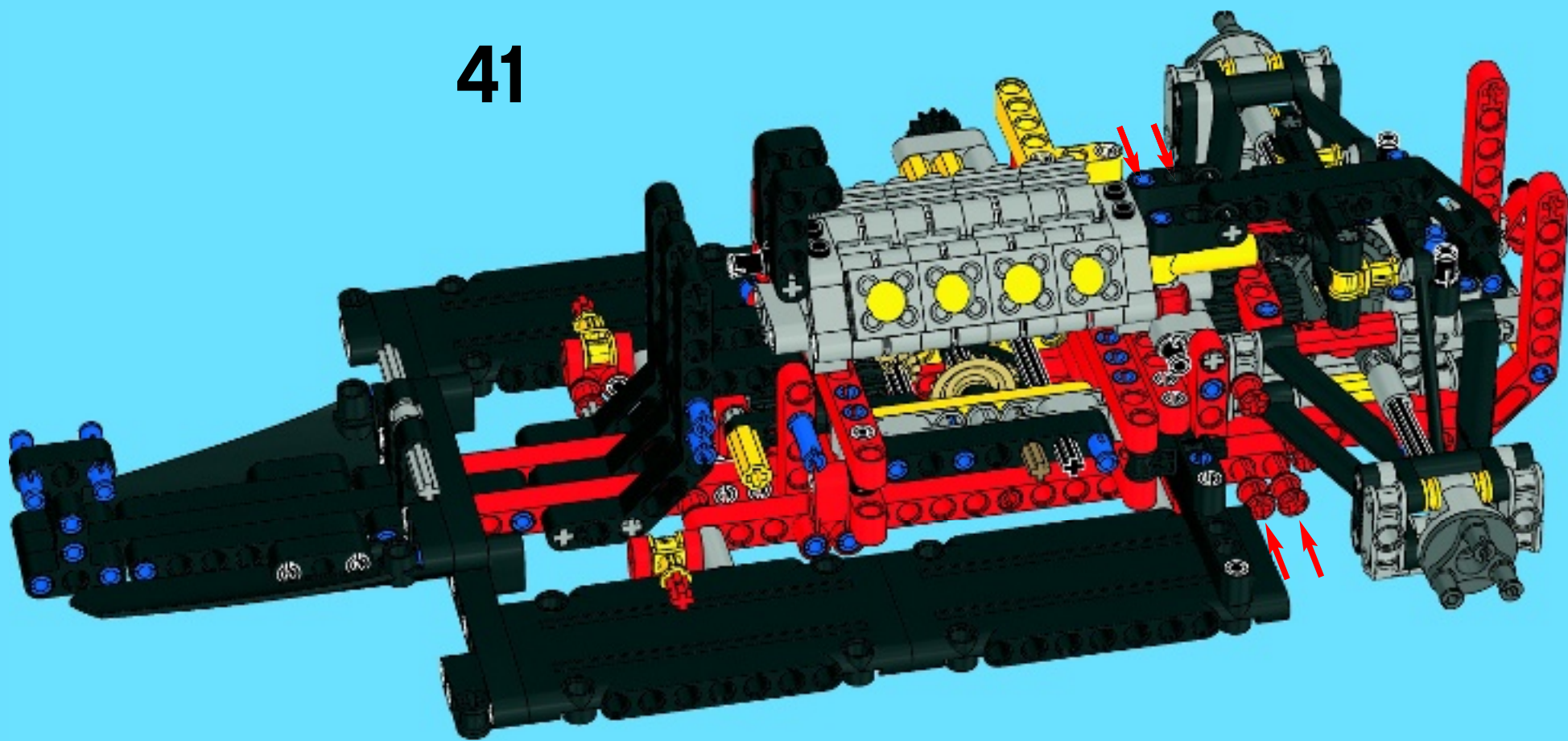



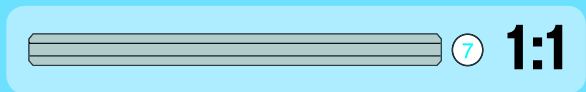
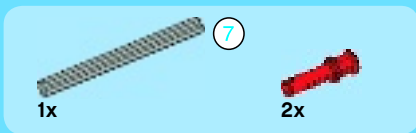

42

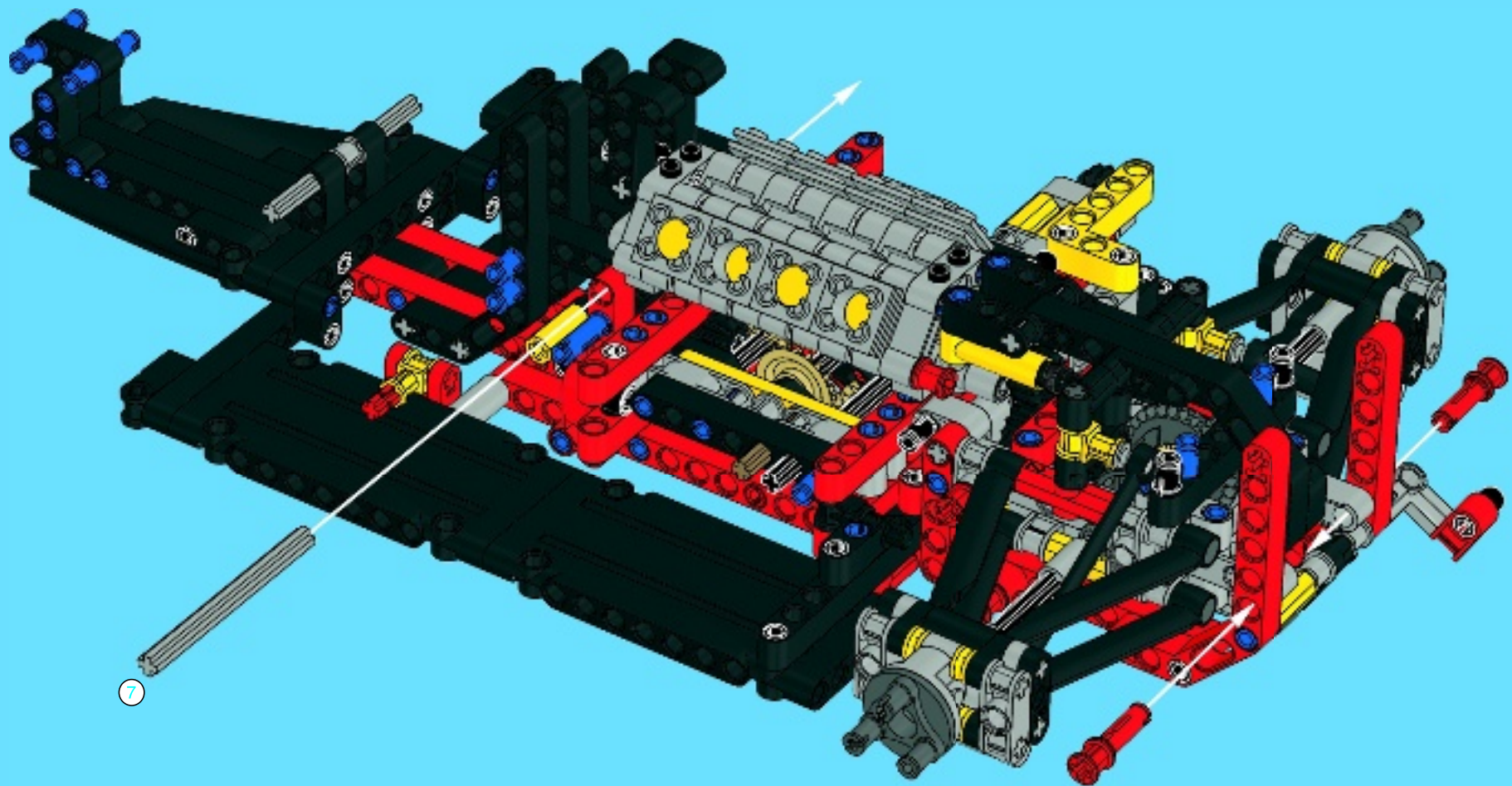



43

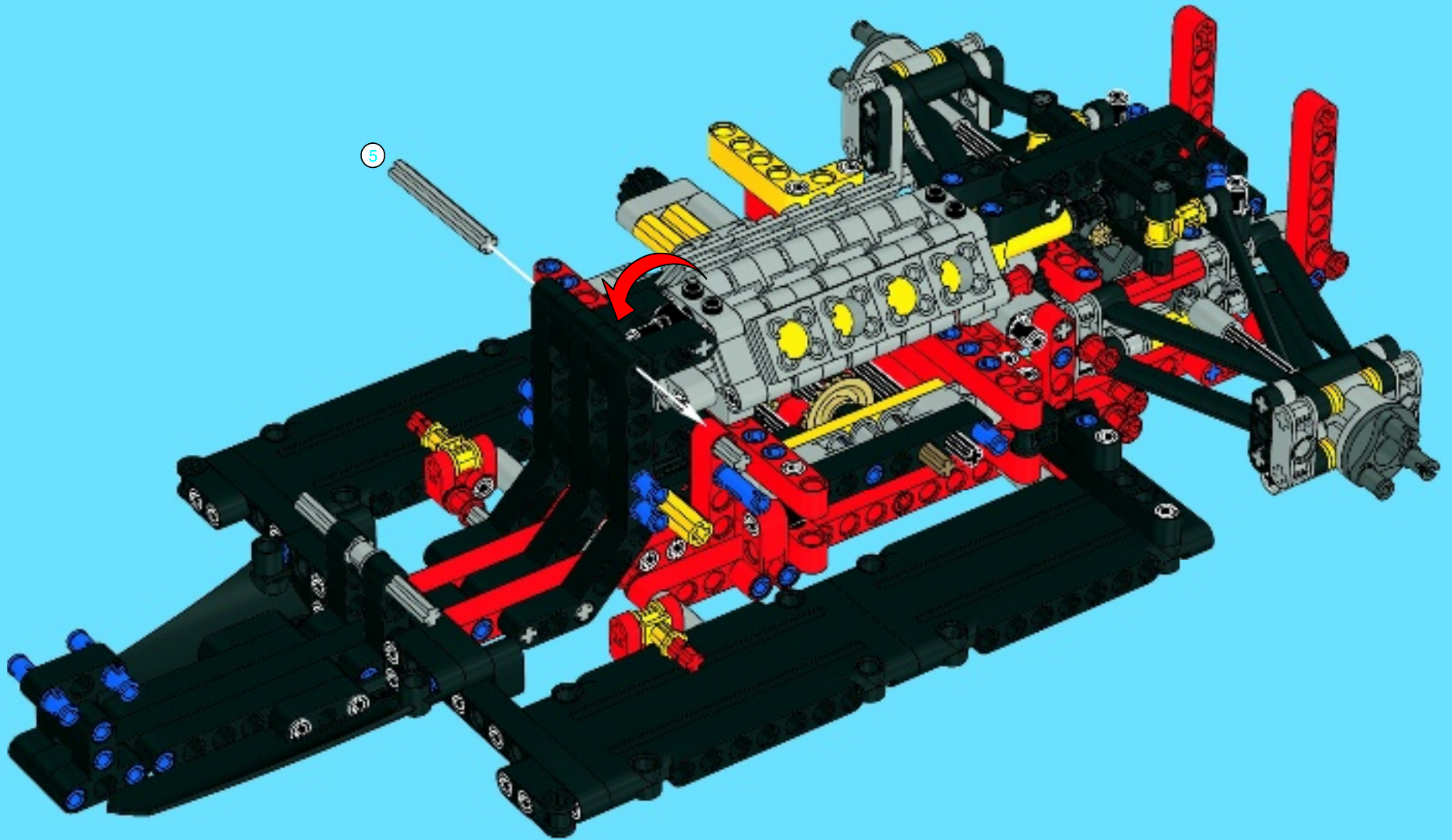

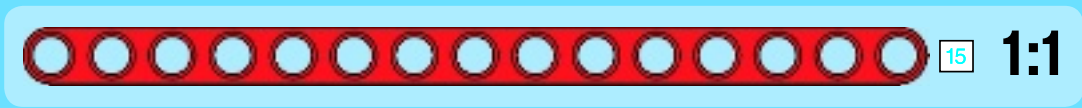

44

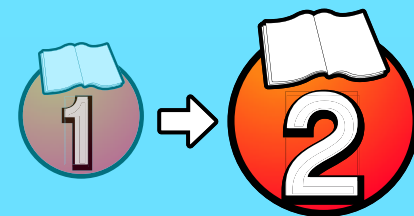
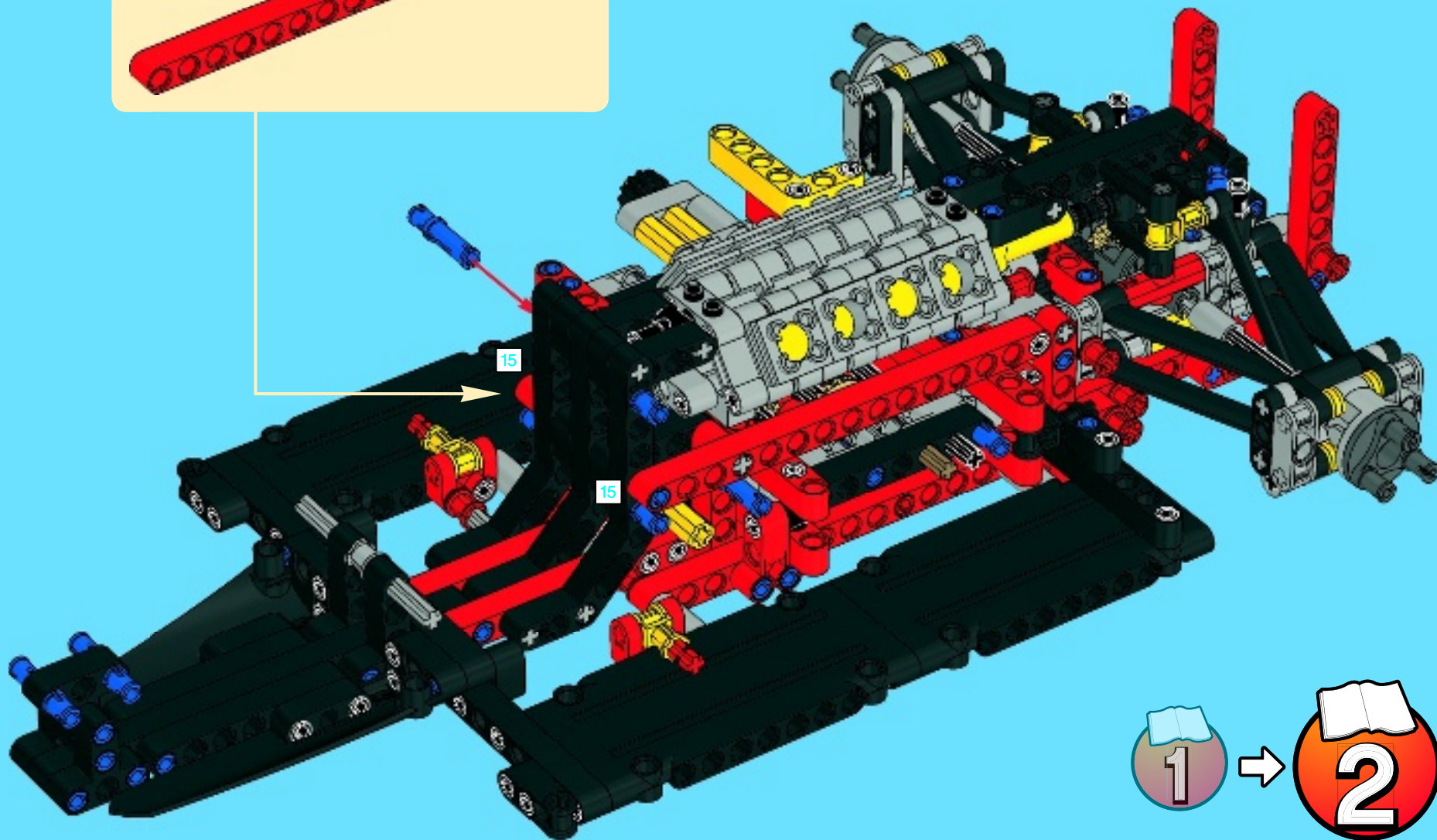



# WIN!

Go to [www.LEGOsurvey.com/product](http://www.LEGOsurvey.com/product) to fill out a survey for a chance to win a cool LEGO® Product.

No purchase necessary.

Open to all residents where not prohibited.



LEGO.com



## [www.LEGOsurvey.com/product](http://www.LEGOsurvey.com/product)

### GEWINNE!

Nimm an der Umfrage auf [www.LEGOsurvey.com/product](http://www.LEGOsurvey.com/product) teil und hab die Chance ein cooles LEGO® Produkt zu gewinnen!

Die Teilnahme am Gewinnspiel führt zu keinerlei Kaufverpflichtungen. Teilnahme in allen nicht ausgeschlossenen Ländern möglich.

### WIN!

Ga naar [www.LEGOsurvey.com/product](http://www.LEGOsurvey.com/product), vul een enquêteformulier in en maak kans op een cool LEGO® product.

Geen aankoopverplichting. Iedereen mag deelnemen, uitzonderd ingezetenden van landen waar een enquêteverbod geldt.

### GAGNE!

Visite [www.LEGOsurvey.com/product](http://www.LEGOsurvey.com/product) pour répondre à un questionnaire et avoir une chance de gagner un produit LEGO® très cool!

Aucune obligation d'achat. Ouvert à tous les résidents des pays autorisés.

### 当てよう!

[www.LEGOsurvey.com/product](http://www.LEGOsurvey.com/product) にアクセスして、アンケートにご記入ください。当選者にはレゴ製品を差し上げます。

お買い上げの必要はありません。

禁止されていない限り、すべての皆様にご利用いただけます。